

Safety and Airspace Regulation Group



CAP 562

**Civil Aircraft Airworthiness Information and
Procedures**

www.caa.co.uk

CAP 562

Civil Aircraft Airworthiness Information and Procedures

© Civil Aviation Authority 2020

All rights reserved. Copies of this publication may be reproduced for personal use, or for use within a company or organisation, but may not otherwise be reproduced for publication.

To use or reference CAA publications for any other purpose, for example within training material for students, please contact the CAA at the address below for formal agreement.

First published July 1990
Issue 2, 26 March 2004
Issue 2, Amendment 1, 16 September 2005
Issue 2, Amendment 2, 31 August 2006
Issue 2, Amendment 3, 21 March 2007
Issue 2, Amendment 4, 28 September 2007
Issue 2, Amendment 5, 27 March 2008
Issue 2, Amendment 6, 30 September 2008
Issue 2, Amendment 7, 31 March 2009
Issue 2, Amendment 8, 11 September 2009
Issue 3, 15 April 2011
Issue 3 (corrected), 13 May 2011
Issue 3, Amendment 1, 30 November 2011
Issue 3, Amendment 2, 31 October 2012
Issue 3, Amendment 3, 29 November 2013
Issue 4, 22 March 2016
Issue 4, Amendment 1, 28 February 2017
Issue 4, Amendment 2, 15 December 2017
Issue 4, Amendment 3, 23 January 2020

Enquiries regarding the content of this publication should be addressed to:
Future Safety, Safety and Airspace Regulation Group, Civil Aviation Authority, Aviation House,
Beehive Ring Road, Crawley, West Sussex, RH6 0YR.

The latest version of this document is available in electronic format at www.caa.co.uk

List of Effective Pages

Part	Chapter	Page	Date	Part	Chapter	Page	Date
		iii	23 Jan 2020	Chapter B	Leaflet B-40	6	23 Jan 2020
		iv	23 Jan 2020	Chapter B	Leaflet B-40	7	23 Jan 2020
		v	23 Jan 2020	Chapter B	Leaflet B-40	8	23 Jan 2020
		vi	23 Jan 2020	Chapter B	Leaflet B-40	9	23 Jan 2020
		vii	23 Jan 2020	Chapter B	Leaflet B-40, Annex A	1	23 Jan 2020
		viii	23 Jan 2020	Chapter B	Leaflet B-40, Annex A	2	23 Jan 2020
		ix	23 Jan 2020	Chapter B	Leaflet B-40, Annex A	3	23 Jan 2020
		x	23 Jan 2020	Chapter B	Leaflet B-40, Annex A	4	23 Jan 2020
		xi	23 Jan 2020	Chapter B	Leaflet B-40, Annex A	5	23 Jan 2020
		xii	23 Jan 2020	Chapter B	Leaflet B-40, Annex A	6	23 Jan 2020
		xiii	23 Jan 2020	Chapter B	Leaflet B-60	1	30 Nov 2011
		xiv	23 Jan 2020	Chapter B	Leaflet B-60	2	29 Nov 2013
		xv	23 Jan 2020	Chapter B	Leaflet B-60	3	29 Nov 2013
		xvi	23 Jan 2020	Chapter B	Leaflet B-60	4	29 Nov 2013
Contents		1	23 Jan 2020	Chapter B	Leaflet B-70	1	15 April 2011
Contents		2	29 Nov 2013	Chapter B	Leaflet B-80	1	15 April 2011
Contents		3	29 Nov 2013	Chapter B	Leaflet B-80	2	15 April 2011
Contents		4	29 Nov 2013	Chapter B	Leaflet B-80	3	15 April 2011
Contents		5	29 Nov 2013	Chapter B	Leaflet B-80	4	15 April 2011
Contents		6	23 Jan 2020	Chapter B	Leaflet B-80	5	15 April 2011
Contents		7	29 Nov 2013	Chapter B	Leaflet B-90	1	30 Nov 2011
Contents		8	23 Jan 2020	Chapter B	Leaflet B-90	2	30 Nov 2011
Revision History		1	30 Nov 2011	Chapter B	Leaflet B-90, Appendix 1	1	31 October 2012
Revision History		2	29 Nov 2013	Chapter B	Leaflet B-90, Appendix 2	1	29 Nov 2013
Revision History		3	23 Jan 2020	Chapter B	Leaflet B-90, Appendix 3	1	30 Nov 2011
Foreword		1	23 Jan 2020	Chapter B	Leaflet B-90, Appendix 4	1	30 Nov 2011
Foreword		2	23 Jan 2020	Chapter B	Leaflet B-100	1	15 April 2011
Chapter B	Leaflet B-20	1	22 March 2016	Chapter B	Leaflet B-100	2	15 April 2011
Chapter B	Leaflet B-20	2	15 April 2011	Chapter B	Leaflet B-110	1	15 April 2011
Chapter B	Leaflet B-20	3	15 April 2011	Chapter B	Leaflet B-110	2	15 April 2011
Chapter B	Leaflet B-30	1	15 April 2011	Chapter B	Leaflet B-110	3	15 April 2011
Chapter B	Leaflet B-30	2	15 April 2011	Chapter B	Leaflet B-110	4	15 April 2011
Chapter B	Leaflet B-30, Appendix 1	1	15 April 2011	Chapter B	Leaflet B-110	5	15 April 2011
Chapter B	Leaflet B-30, Appendix 1	2	15 April 2011	Chapter B	Leaflet B-110	6	15 April 2011
Chapter B	Leaflet B-30, Appendix 1	3	15 April 2011	Chapter B	Leaflet B-120	1	15 April 2011
Chapter B	Leaflet B-30, Appendix 1	4	15 April 2011	Chapter B	Leaflet B-120	2	15 April 2011
Chapter B	Leaflet B-30, Appendix 1	5	15 April 2011	Chapter B	Leaflet B-130	1	15 April 2011
Chapter B	Leaflet B-30, Appendix 1	6	15 April 2011	Chapter B	Leaflet B-130	2	15 April 2011
Chapter B	Leaflet B-30, Appendix 1	7	15 April 2011	Chapter B	Leaflet B-130	3	15 April 2011
Chapter B	Leaflet B-40	1	23 Jan 2020	Chapter B	Leaflet B-140	1	15 April 2011
Chapter B	Leaflet B-40	2	23 Jan 2020	Chapter B	Leaflet B-140, Appendix 1	1	15 April 2011
Chapter B	Leaflet B-40	3	23 Jan 2020	Chapter B	Leaflet B-140, Appendix 1	2	15 April 2011
Chapter B	Leaflet B-40	4	23 Jan 2020	Chapter B	Leaflet B-140, Appendix 2	1	15 April 2011
Chapter B	Leaflet B-40	5	23 Jan 2020	Chapter B	Leaflet B-140, Appendix 2	2	15 April 2011
				Chapter B	Leaflet B-150	1	15 April 2011

Part	Chapter	Page	Date	Part	Chapter	Page	Date
Chapter B	Leaflet B-160	1	31 October 2012	Chapter B	Leaflet B-180	38	15 April 2011
Chapter B	Leaflet B-160	2	31 October 2012	Chapter B	Leaflet B-180	39	15 April 2011
Chapter B	Leaflet B-160	3	31 October 2012	Chapter B	Leaflet B-180	40	15 April 2011
Chapter B	Leaflet B-160	4	31 October 2012	Chapter B	Leaflet B-180	41	15 April 2011
Chapter B	Leaflet B-160	5	31 October 2012	Chapter B	Leaflet B-180	42	15 April 2011
Chapter B	Leaflet B-160	6	31 October 2012	Chapter B	Leaflet B-180	43	15 April 2011
Chapter B	Leaflet B-160	7	31 October 2012	Chapter B	Leaflet B-180	44	15 April 2011
Chapter B	Leaflet B-170	1	15 April 2011	Chapter B	Leaflet B-180	45	15 April 2011
Chapter B	Leaflet B-170	2	15 April 2011	Chapter B	Leaflet B-180	46	31 October 2012
Chapter B	Leaflet B-180	1	15 April 2011	Chapter B	Leaflet B-180	47	31 October 2012
Chapter B	Leaflet B-180	2	15 April 2011	Chapter B	Leaflet B-180	48	15 April 2011
Chapter B	Leaflet B-180	3	15 April 2011	Chapter B	Leaflet B-180	49	15 April 2011
Chapter B	Leaflet B-180	4	15 April 2011	Chapter B	Leaflet B-180	50	31 October 2012
Chapter B	Leaflet B-180	5	15 April 2011	Chapter B	Leaflet B-180	51	15 April 2011
Chapter B	Leaflet B-180	6	23 Jan 2020	Chapter B	Leaflet B-180	52	15 April 2011
Chapter B	Leaflet B-180	7	23 Jan 2020	Chapter B	Leaflet B-180	53	15 April 2011
Chapter B	Leaflet B-180	8	23 Jan 2020	Chapter B	Leaflet B-180	54	15 April 2011
Chapter B	Leaflet B-180	9	23 Jan 2020	Chapter B	Leaflet B-180	55	31 October 2012
Chapter B	Leaflet B-180	10	23 Jan 2020	Chapter B	Leaflet B-180	56	31 October 2012
Chapter B	Leaflet B-180	11	23 Jan 2020	Chapter B	Leaflet B-180	57	15 April 2011
Chapter B	Leaflet B-180	12	15 April 2011	Chapter B	Leaflet B-180	58	15 April 2011
Chapter B	Leaflet B-180	13	15 April 2011	Chapter B	Leaflet B-180	59	15 April 2011
Chapter B	Leaflet B-180	14	15 April 2011	Chapter B	Leaflet B-180	60	15 April 2011
Chapter B	Leaflet B-180	15	15 April 2011	Chapter B	Leaflet B-180	61	31 October 2012
Chapter B	Leaflet B-180	16	15 April 2011	Chapter B	Leaflet B-180	62	15 April 2011
Chapter B	Leaflet B-180	17	15 April 2011	Chapter B	Leaflet B-180	63	15 April 2011
Chapter B	Leaflet B-180	18	15 April 2011	Chapter B	Leaflet B-180	64	15 April 2011
Chapter B	Leaflet B-180	19	15 April 2011	Chapter B	Leaflet B-180	65	31 October 2012
Chapter B	Leaflet B-180	20	15 April 2011	Chapter B	Leaflet B-180	66	15 April 2011
Chapter B	Leaflet B-180	21	15 April 2011	Chapter B	Leaflet B-180	67	15 April 2011
Chapter B	Leaflet B-180	22	15 April 2011	Chapter B	Leaflet B-180	68	31 October 2012
Chapter B	Leaflet B-180	23	15 April 2011	Chapter B	Leaflet B-180	69	15 April 2011
Chapter B	Leaflet B-180	24	15 April 2011	Chapter B	Leaflet B-190	1	15 April 2011
Chapter B	Leaflet B-180	25	15 April 2011	Chapter B	Leaflet B-190	2	15 April 2011
Chapter B	Leaflet B-180	26	15 April 2011	Chapter B	Leaflet B-190	3	15 April 2011
Chapter B	Leaflet B-180	27	15 April 2011	Chapter B	Leaflet B-190	4	15 April 2011
Chapter B	Leaflet B-180	28	15 April 2011	Chapter B	Leaflet B-200	1	15 April 2011
Chapter B	Leaflet B-180	29	15 April 2011	Chapter B	Leaflet B-200	2	15 April 2011
Chapter B	Leaflet B-180	30	15 April 2011	Chapter B	Leaflet B-200	3	15 April 2011
Chapter B	Leaflet B-180	31	15 April 2011	Chapter B	Leaflet B-210	1	15 April 2011
Chapter B	Leaflet B-180	32	15 April 2011	Chapter B	Leaflet B-210	2	15 April 2011
Chapter B	Leaflet B-180	33	15 April 2011	Chapter B	Leaflet B-210	3	31 October 2012
Chapter B	Leaflet B-180	34	15 April 2011	Chapter B	Leaflet B-220	1	15 April 2011
Chapter B	Leaflet B-180	35	15 April 2011	Chapter B	Leaflet B-220	2	15 April 2011
Chapter B	Leaflet B-180	36	15 April 2011	Chapter B	Leaflet B-230	1	15 April 2011
Chapter B	Leaflet B-180	37	15 April 2011	Chapter B	Leaflet B-240	1	15 April 2011

Part	Chapter	Page	Date	Part	Chapter	Page	Date
Chapter B	Leaflet B-250	1	15 April 2011	Chapter C	Leaflet C-110	2	15 April 2011
Chapter B	Leaflet B-250	2	15 April 2011	Chapter C	Leaflet C-120	1	15 April 2011
Chapter B	Leaflet B-250	3	30 Nov 2011	Chapter C	Leaflet C-120, Appendix 1	1	15 April 2011
Chapter B	Leaflet B-250	4	15 April 2011	Chapter C	Leaflet C-120, Appendix 1	2	15 April 2011
Chapter C	Leaflet C-20	1	30 Nov 2011	Chapter C	Leaflet C-120, Appendix 1	3	15 April 2011
Chapter C	Leaflet C-20	2	15 April 2011	Chapter C	Leaflet C-120, Appendix 1	4	15 April 2011
Chapter C	Leaflet C-20	3	15 April 2011	Chapter C	Leaflet C-120, Appendix 1	5	15 April 2011
Chapter C	Leaflet C-20	4	15 April 2011	Chapter C	Leaflet C-120, Appendix 2	1	15 April 2011
Chapter C	Leaflet C-20	5	15 April 2011	Chapter C	Leaflet C-120, Appendix 2	2	15 April 2011
Chapter C	Leaflet C-20	6	15 April 2011	Chapter C	Leaflet C-120, Appendix 2	3	15 April 2011
Chapter C	Leaflet C-20, Appendix 1	1	15 April 2011	Chapter C	Leaflet C-120, Appendix 2	4	15 April 2011
Chapter C	Leaflet C-20, Appendix 1	2	15 April 2011	Chapter C	Leaflet C-120, Appendix 2	5	15 April 2011
Chapter C	Leaflet C-20, Appendix 2	1	15 April 2011	Chapter C	Leaflet C-130	1	15 April 2011
Chapter C	Leaflet C-20, Appendix 2	2	15 April 2011	Chapter C	Leaflet C-130	2	15 April 2011
Chapter C	Leaflet C-30	1	15 April 2011	Chapter C	Leaflet C-140	1	15 April 2011
Chapter C	Leaflet C-40	1	15 April 2011	Chapter C	Leaflet C-140	2	15 April 2011
Chapter C	Leaflet C-40, Appendix 1	1	15 April 2011	Chapter C	Leaflet C-140	3	15 April 2011
Chapter C	Leaflet C-50	1	15 April 2011	Chapter C	Leaflet C-150	1	15 April 2011
Chapter C	Leaflet C-50	2	15 April 2011	Chapter C	Leaflet C-150	2	15 April 2011
Chapter C	Leaflet C-50	3	15 April 2011	Chapter C	Leaflet C-150	3	15 April 2011
Chapter C	Leaflet C-50	4	15 April 2011	Chapter C	Leaflet C-150	4	15 April 2011
Chapter C	Leaflet C-50	5	15 April 2011	Chapter C	Leaflet C-150	5	15 April 2011
Chapter C	Leaflet C-50	6	15 April 2011	Chapter C	Leaflet C-150, Appendix 1	1	15 April 2011
Chapter C	Leaflet C-50	7	15 April 2011	Chapter C	Leaflet C-150, Appendix 1	2	15 April 2011
Chapter C	Leaflet C-50, Appendix 1	1	15 April 2011	Chapter C	Leaflet C-150, Appendix 2	1	15 April 2011
Chapter C	Leaflet C-50, Appendix 2	1	15 April 2011	Chapter C	Leaflet C-150, Appendix 2	2	15 April 2011
Chapter C	Leaflet C-50, Appendix 2	2	15 April 2011	Chapter C	Leaflet C-150, Appendix 2	3	15 April 2011
Chapter C	Leaflet C-50, Appendix 3	1	15 April 2011	Chapter C	Leaflet C-150, Appendix 3	1	15 April 2011
Chapter C	Leaflet C-50, Appendix 3	2	15 April 2011	Chapter C	Leaflet C-150, Appendix 3	2	15 April 2011
Chapter C	Leaflet C-60	1	29 Nov 2013	Chapter C	Leaflet C-150, Appendix 4	1	15 April 2011
Chapter C	Leaflet C-60	2	30 Nov 2011	Chapter C	Leaflet C-160	1	15 April 2011
Chapter C	Leaflet C-60	3	30 Nov 2011	Chapter C	Leaflet C-160	2	15 April 2011
Chapter C	Leaflet C-60	4	30 Nov 2011	Chapter C	Leaflet C-160	3	15 April 2011
Chapter C	Leaflet C-60	5	30 Nov 2011	Chapter C	Leaflet C-170	1	15 April 2011
Chapter C	Leaflet C-60	6	30 Nov 2011	Chapter C	Leaflet C-180	1	22 March 2016
Chapter C	Leaflet C-70	1	15 April 2011	Chapter C	Leaflet C-180	2	22 March 2016
Chapter C	Leaflet C-70	2	15 April 2011	Chapter C	Leaflet C-180	3	22 March 2016
Chapter C	Leaflet C-80	1	15 April 2011	Chapter C	Leaflet C-180	4	22 March 2016
Chapter C	Leaflet C-80	2	15 April 2011	Chapter C	Leaflet C-180	5	22 March 2016
Chapter C	Leaflet C-80	3	15 April 2011	Chapter C	Leaflet C-180	6	22 March 2016
Chapter C	Leaflet C-90	1	15 April 2011	Chapter C	Leaflet C-180	7	22 March 2016
Chapter C	Leaflet C-90	2	31 October 2012	Chapter C	Leaflet C-180	8	22 March 2016
Chapter C	Leaflet C-90	3	31 October 2012	Chapter C	Leaflet C-180	9	22 March 2016
Chapter C	Leaflet C-100	1	15 April 2011	Chapter C	Leaflet C-180	10	22 March 2016
Chapter C	Leaflet C-100	2	15 April 2011	Chapter C	Leaflet C-180	11	22 March 2016
Chapter C	Leaflet C-100	3	15 April 2011	Chapter C	Leaflet C-180	12	22 March 2016
Chapter C	Leaflet C-100	4	15 April 2011	Chapter C	Leaflet C-180	13	22 March 2016
Chapter C	Leaflet C-110	1	15 April 2011	Chapter C	Leaflet C-180	14	22 March 2016

Part	Chapter	Page	Date	Part	Chapter	Page	Date
Chapter C	Leaflet C-180	15	22 March 2016	Chapter D	Leaflet D-40	3	15 April 2011
Chapter C	Leaflet C-180	16	22 March 2016	Chapter D	Leaflet D-40	4	15 April 2011
Chapter D	Leaflet D-10	1	15 April 2011	Chapter D	Leaflet D-40	5	15 April 2011
Chapter D	Leaflet D-10	2	15 April 2011	Chapter D	Leaflet D-40	6	15 April 2011
Chapter D	Leaflet D-10	3	15 April 2011	Chapter D	Leaflet D-40	7	15 April 2011
Chapter D	Leaflet D-10	4	15 April 2011	Chapter D	Leaflet D-40	8	15 April 2011
Chapter D	Leaflet D-10	5	15 April 2011	Chapter D	Leaflet D-40	9	15 April 2011
Chapter D	Leaflet D-10	6	15 April 2011	Chapter D	Leaflet D-40	10	15 April 2011
Chapter D	Leaflet D-10	7	15 April 2011	Chapter D	Leaflet D-40	11	15 April 2011
Chapter D	Leaflet D-10	8	15 April 2011	Chapter D	Leaflet D-40	12	15 April 2011
Chapter D	Leaflet D-10	9	15 April 2011	Chapter D	Leaflet D-40	13	15 April 2011
Chapter D	Leaflet D-10	10	15 April 2011	Chapter D	Leaflet D-40	14	15 April 2011
Chapter D	Leaflet D-10	11	15 April 2011	Chapter D	Leaflet D-40	15	15 April 2011
Chapter D	Leaflet D-10	12	15 April 2011	Chapter D	Leaflet D-40	16	15 April 2011
Chapter D	Leaflet D-10	13	15 April 2011	Chapter D	Leaflet D-40	17	15 April 2011
Chapter D	Leaflet D-10	14	15 April 2011	Chapter E	Leaflet E-10	1	15 April 2011
Chapter D	Leaflet D-10	15	15 April 2011	Chapter E	Leaflet E-10	2	15 April 2011
Chapter D	Leaflet D-10	16	15 April 2011	Chapter E	Leaflet E-10	3	15 April 2011
Chapter D	Leaflet D-10	17	15 April 2011	Chapter E	Leaflet E-10	4	15 April 2011
Chapter D	Leaflet D-10	18	15 April 2011	Chapter E	Leaflet E-10	5	15 April 2011
Chapter D	Leaflet D-10	19	15 April 2011	Chapter E	Leaflet E-10	6	15 April 2011
Chapter D	Leaflet D-10	20	15 April 2011	Chapter E	Leaflet E-10	7	15 April 2011
Chapter D	Leaflet D-20	1	31 October 2012	Chapter E	Leaflet E-10	8	15 April 2011
Chapter D	Leaflet D-20	2	15 April 2011	Chapter E	Leaflet E-10	9	15 April 2011
Chapter D	Leaflet D-20	3	15 April 2011	Chapter E	Leaflet E-10	10	15 April 2011
Chapter D	Leaflet D-30	1	15 April 2011	Chapter E	Leaflet E-10	11	15 April 2011
Chapter D	Leaflet D-30	2	15 April 2011	Chapter E	Leaflet E-20	1	15 April 2011
Chapter D	Leaflet D-30	3	15 April 2011	Chapter E	Leaflet E-20	2	15 April 2011
Chapter D	Leaflet D-30	4	15 April 2011	Chapter E	Leaflet E-20	3	15 April 2011
Chapter D	Leaflet D-30	5	15 April 2011	Chapter E	Leaflet E-20	4	15 April 2011
Chapter D	Leaflet D-30	6	15 April 2011	Chapter E	Leaflet E-20	5	15 April 2011
Chapter D	Leaflet D-30	7	15 April 2011	Chapter E	Leaflet E-20	6	15 April 2011
Chapter D	Leaflet D-30	8	15 April 2011	Chapter E	Leaflet E-20	7	15 April 2011
Chapter D	Leaflet D-30	9	15 April 2011	Chapter E	Leaflet E-30	1	15 April 2011
Chapter D	Leaflet D-30	10	15 April 2011	Chapter E	Leaflet E-30	2	15 April 2011
Chapter D	Leaflet D-30	11	15 April 2011	Chapter E	Leaflet E-30	3	15 April 2011
Chapter D	Leaflet D-30	12	15 April 2011	Chapter E	Leaflet E-30	4	15 April 2011
Chapter D	Leaflet D-30	13	15 April 2011	Chapter E	Leaflet E-30	5	15 April 2011
Chapter D	Leaflet D-30	14	15 April 2011	Chapter E	Leaflet E-30	6	15 April 2011
Chapter D	Leaflet D-30	15	15 April 2011	Chapter E	Leaflet E-30	7	15 April 2011
Chapter D	Leaflet D-30	16	15 April 2011	Chapter E	Leaflet E-30	8	15 April 2011
Chapter D	Leaflet D-30	17	15 April 2011	Chapter E	Leaflet E-30	9	15 April 2011
Chapter D	Leaflet D-30	18	15 April 2011	Chapter E	Leaflet E-30	10	15 April 2011
Chapter D	Leaflet D-30	19	15 April 2011	Chapter E	Leaflet E-30	11	15 April 2011
Chapter D	Leaflet D-30	20	15 April 2011	Chapter E	Leaflet E-30	12	15 April 2011
Chapter D	Leaflet D-30	21	15 April 2011	Chapter E	Leaflet E-40	1	15 April 2011
Chapter D	Leaflet D-40	1	15 April 2011	Chapter E	Leaflet E-40	2	15 April 2011
Chapter D	Leaflet D-40	2	15 April 2011	Chapter E	Leaflet E-40	3	15 April 2011

Part	Chapter	Page	Date	Part	Chapter	Page	Date
Chapter F	Leaflet F-80	8	15 April 2011	Chapter H	Leaflet H-20	3	31 October 2012
Chapter F	Leaflet F-80	9	15 April 2011	Chapter H	Leaflet H-20	4	31 October 2012
Chapter F	Leaflet F-80	10	15 April 2011	Chapter H	Leaflet H-20	5	31 October 2012
Chapter F	Leaflet F-80	11	15 April 2011	Chapter H	Leaflet H-20	6	31 October 2012
Chapter F	Leaflet F-80	12	15 April 2011	Chapter H	Leaflet H-20	7	31 October 2012
Chapter F	Leaflet F-80	13	15 April 2011	Chapter H	Leaflet H-20	8	31 October 2012
Chapter F	Leaflet F-80	14	15 April 2011	Chapter H	Leaflet H-20	9	31 October 2012
Chapter F	Leaflet F-90	1	15 April 2011	Chapter H	Leaflet H-20	10	31 October 2012
Chapter F	Leaflet F-90	2	15 April 2011	Chapter H	Leaflet H-20	11	31 October 2012
Chapter F	Leaflet F-90	3	15 April 2011	Chapter H	Leaflet H-20	12	31 October 2012
Chapter F	Leaflet F-90	4	15 April 2011	Chapter H	Leaflet H-20	13	31 October 2012
Chapter F	Leaflet F-90	5	15 April 2011	Chapter H	Leaflet H-20	14	31 October 2012
Chapter F	Leaflet F-90	6	15 April 2011	Chapter H	Leaflet H-20	15	31 October 2012
Chapter F	Leaflet F-90	7	15 April 2011	Chapter H	Leaflet H-20	16	31 October 2012
Chapter F	Leaflet F-90	8	15 April 2011	Chapter H	Leaflet H-20	17	31 October 2012
Chapter F	Leaflet F-90	9	15 April 2011	Chapter H	Leaflet H-20	18	31 October 2012
Chapter F	Leaflet F-90	10	15 April 2011	Chapter H	Leaflet H-20	19	31 October 2012
Chapter G	Leaflet G-10	1	15 April 2011	Chapter H	Leaflet H-30	1	31 October 2012
Chapter G	Leaflet G-10	2	15 April 2011	Chapter H	Leaflet H-30	2	31 October 2012
Chapter G	Leaflet G-10	3	15 April 2011	Chapter H	Leaflet H-30	3	31 October 2012
Chapter G	Leaflet G-10	4	15 April 2011	Chapter H	Leaflet H-30	4	31 October 2012
Chapter G	Leaflet G-10	5	15 April 2011	Chapter H	Leaflet H-30	5	31 October 2012
Chapter G	Leaflet G-10	6	15 April 2011	Chapter H	Leaflet H-30	6	31 October 2012
Chapter G	Leaflet G-10	7	15 April 2011	Chapter H	Leaflet H-30	7	31 October 2012
Chapter G	Leaflet G-10	8	15 April 2011	Chapter H	Leaflet H-40	1	15 April 2011
Chapter G	Leaflet G-10	9	15 April 2011	Chapter H	Leaflet H-40	2	15 April 2011
Chapter G	Leaflet G-10	10	15 April 2011	Chapter H	Leaflet H-50	1	15 April 2011
Chapter G	Leaflet G-10	11	15 April 2011	Chapter H	Leaflet H-50	2	15 April 2011
Chapter G	Leaflet G-10	12	15 April 2011	Chapter H	Leaflet H-50	3	15 April 2011
Chapter G	Leaflet G-10	13	15 April 2011	Chapter H	Leaflet H-50	4	15 April 2011
Chapter G	Leaflet G-10	14	15 April 2011	Chapter H	Leaflet H-50	5	15 April 2011
Chapter G	Leaflet G-10	15	15 April 2011	Chapter H	Leaflet H-50	6	15 April 2011
Chapter G	Leaflet G-10	16	15 April 2011	Chapter H	Leaflet H-60	1	15 April 2011
Chapter G	Leaflet G-10	17	15 April 2011	Chapter H	Leaflet H-60	2	15 April 2011
Chapter G	Leaflet G-20	1	15 April 2011	Chapter H	Leaflet H-60	3	15 April 2011
Chapter G	Leaflet G-20	2	15 April 2011	Chapter H	Leaflet H-60	4	15 April 2011
Chapter G	Leaflet G-20	3	15 April 2011	Chapter H	Leaflet H-60, Appendix 1	1	15 April 2011
Chapter G	Leaflet G-20	4	15 April 2011	Chapter 5	Leaflet 5-10	1	15 April 2011
Chapter G	Leaflet G-20	5	15 April 2011	Chapter 5	Leaflet 5-10	2	15 April 2011
Chapter G	Leaflet G-20	6	15 April 2011	Chapter 5	Leaflet 5-10	3	15 April 2011
Chapter G	Leaflet G-20	7	15 April 2011	Chapter 5	Leaflet 5-10	4	15 April 2011
Chapter G	Leaflet G-20	8	15 April 2011	Chapter 5	Leaflet 5-10	5	15 April 2011
Chapter G	Leaflet G-20	9	15 April 2011	Chapter 5	Leaflet 5-10	6	15 April 2011
Chapter G	Leaflet G-20	10	15 April 2011	Chapter 5	Leaflet 5-10	7	15 April 2011
Chapter H	Leaflet H-10	1	31 October 2012	Chapter 5	Leaflet 5-10	8	15 April 2011
Chapter H	Leaflet H-10	2	31 October 2012	Chapter 5	Leaflet 5-10	9	15 April 2011
Chapter H	Leaflet H-20	1	31 October 2012	Chapter 5	Leaflet 5-10	10	15 April 2011
Chapter H	Leaflet H-20	2	31 October 2012	Chapter 5	Leaflet 5-10	11	15 April 2011

Part	Chapter	Page	Date	Part	Chapter	Page	Date
Chapter 25	Leaflet 25-80	4	23 Jan 2020	Chapter 32	Leaflet 32-10	14	15 April 2011
Chapter 25	Leaflet 25-80, Appendix 1	1	23 Jan 2020	Chapter 32	Leaflet 32-10	15	15 April 2011
Chapter 25	Leaflet 25-80, Appendix 1	2	23 Jan 2020	Chapter 32	Leaflet 32-10	16	15 April 2011
Chapter 25	Leaflet 25-80, Appendix 1	3	23 Jan 2020	Chapter 32	Leaflet 32-10	17	15 April 2011
Chapter 25	Leaflet 25-80, Appendix 2	1	23 Jan 2020	Chapter 32	Leaflet 32-10	18	15 April 2011
Chapter 25	Leaflet 25-90	1	22 March 2016	Chapter 32	Leaflet 32-10	19	15 April 2011
Chapter 25	Leaflet 25-90	2	22 March 2016	Chapter 32	Leaflet 32-10	20	15 April 2011
Chapter 25	Leaflet 25-90	3	22 March 2016	Chapter 32	Leaflet 32-10	21	15 April 2011
Chapter 25	Leaflet 25-90	4	22 March 2016	Chapter 32	Leaflet 32-10	22	15 April 2011
				Chapter 32	Leaflet 32-10	23	15 April 2011
Chapter 25	Leaflet 25-100	1	22 March 2016	Chapter 32	Leaflet 32-20	1	15 April 2011
Chapter 25	Leaflet 25-100	2	22 March 2016	Chapter 32	Leaflet 32-20	2	15 April 2011
Chapter 25	Leaflet 25-100	3	22 March 2016	Chapter 32	Leaflet 32-20	3	15 April 2011
Chapter 25	Leaflet 25-100	4	22 March 2016	Chapter 32	Leaflet 32-20	4	15 April 2011
Chapter 25	Leaflet 25-100	5	22 March 2016	Chapter 32	Leaflet 32-20	5	15 April 2011
Chapter 25	Leaflet 25-100	6	22 March 2016	Chapter 32	Leaflet 32-20	6	15 April 2011
Chapter 25	Leaflet 25-100	7	22 March 2016	Chapter 32	Leaflet 32-20	7	15 April 2011
Chapter 25	Leaflet 25-100	8	22 March 2016	Chapter 32	Leaflet 32-20	8	15 April 2011
Chapter 25	Leaflet 25-110	1	22 March 2016	Chapter 32	Leaflet 32-20	9	15 April 2011
Chapter 25	Leaflet 25-110	2	22 March 2016	Chapter 32	Leaflet 32-20	10	15 April 2011
Chapter 25	Leaflet 25-120	1	22 March 2016	Chapter 32	Leaflet 32-20	11	15 April 2011
Chapter 25	Leaflet 25-120	2	22 March 2016	Chapter 32	Leaflet 32-20	12	15 April 2011
Chapter 25	Leaflet 25-120	3	22 March 2016	Chapter 32	Leaflet 32-20	13	15 April 2011
Chapter 25	Leaflet 25-120	4	22 March 2016	Chapter 32	Leaflet 32-20	14	15 April 2011
Chapter 25	Leaflet 25-130	1	22 March 2016	Chapter 32	Leaflet 32-20	15	15 April 2011
Chapter 25	Leaflet 25-130	2	22 March 2016	Chapter 32	Leaflet 32-20	16	15 April 2011
Chapter 25	Leaflet 25-130	3	22 March 2016	Chapter 32	Leaflet 32-20	17	15 April 2011
Chapter 28	Leaflet 28-10	1	15 April 2011	Chapter 32	Leaflet 32-20	18	15 April 2011
Chapter 28	Leaflet 28-10	2	15 April 2011	Chapter 32	Leaflet 32-20	19	15 April 2011
Chapter 28	Leaflet 28-20	1	31 October 2012	Chapter 32	Leaflet 32-20	20	15 April 2011
Chapter 28	Leaflet 28-20	2	31 October 2012	Chapter 32	Leaflet 32-20	21	15 April 2011
Chapter 28	Leaflet 28-20	3	31 October 2012	Chapter 32	Leaflet 32-30	1	15 April 2011
Chapter 28	Leaflet 28-20	4	31 October 2012	Chapter 33	Leaflet 33-10	1	15 April 2011
Chapter 31	Leaflet 31-10	1	15 April 2011	Chapter 33	Leaflet 33-10	2	15 April 2011
Chapter 31	Leaflet 31-10	2	15 April 2011	Chapter 33	Leaflet 33-10	3	15 April 2011
Chapter 32	Leaflet 32-10	1	15 April 2011	Chapter 33	Leaflet 33-10	4	15 April 2011
Chapter 32	Leaflet 32-10	2	15 April 2011	Chapter 33	Leaflet 33-20	1	15 April 2011
Chapter 32	Leaflet 32-10	3	15 April 2011	Chapter 33	Leaflet 33-20	2	15 April 2011
Chapter 32	Leaflet 32-10	4	15 April 2011	Chapter 33	Leaflet 33-20	3	15 April 2011
Chapter 32	Leaflet 32-10	5	15 April 2011	Chapter 33	Leaflet 33-20	4	15 April 2011
Chapter 32	Leaflet 32-10	6	15 April 2011	Chapter 33	Leaflet 33-20	5	15 April 2011
Chapter 32	Leaflet 32-10	7	15 April 2011	Chapter 34	Leaflet 34-10	1	30 Nov 2011
Chapter 32	Leaflet 32-10	8	15 April 2011	Chapter 34	Leaflet 34-10	2	15 April 2011
Chapter 32	Leaflet 32-10	9	15 April 2011	Chapter 34	Leaflet 34-10	3	15 April 2011
Chapter 32	Leaflet 32-10	10	15 April 2011	Chapter 34	Leaflet 34-10	4	15 April 2011
Chapter 32	Leaflet 32-10	11	15 April 2011	Chapter 34	Leaflet 34-10	5	15 April 2011
Chapter 32	Leaflet 32-10	12	15 April 2011	Chapter 34	Leaflet 34-10	6	15 April 2011
Chapter 32	Leaflet 32-10	13	15 April 2011	Chapter 34	Leaflet 34-10	7	15 April 2011

Part	Chapter	Page	Date	Part	Chapter	Page	Date
Chapter 34	Leaflet 34-10	8	15 April 2011	Chapter 39	Leaflet 39-40	3	15 April 2011
Chapter 34	Leaflet 34-20	1	15 April 2011	Chapter 39	Leaflet 39-40	4	15 April 2011
Chapter 34	Leaflet 34-20	2	15 April 2011	Chapter 39	Leaflet 39-40	5	15 April 2011
Chapter 34	Leaflet 34-20	3	15 April 2011	Chapter 39	Leaflet 39-40	6	15 April 2011
Chapter 34	Leaflet 34-20	4	15 April 2011	Chapter 44	Leaflet 44-10	1	15 April 2011
Chapter 34	Leaflet 34-20	5	15 April 2011	Chapter 44	Leaflet 44-10	2	15 April 2011
Chapter 34	Leaflet 34-20	6	15 April 2011	Chapter 44	Leaflet 44-10	3	15 April 2011
Chapter 34	Leaflet 34-20	7	15 April 2011	Chapter 44	Leaflet 44-10	4	15 April 2011
Chapter 34	Leaflet 34-20	8	15 April 2011	Chapter 44	Leaflet 44-10	5	15 April 2011
Chapter 34	Leaflet 34-20	9	15 April 2011	Chapter 44	Leaflet 44-10, Appendix 1	1	15 April 2011
Chapter 34	Leaflet 34-20	10	15 April 2011	Chapter 44	Leaflet 44-10, Appendix 1	2	15 April 2011
Chapter 34	Leaflet 34-20	11	15 April 2011	Chapter 44	Leaflet 44-10, Appendix 1	3	15 April 2011
Chapter 34	Leaflet 34-20	12	15 April 2011	Chapter 44	Leaflet 44-10, Appendix 1	4	15 April 2011
Chapter 34	Leaflet 34-20	13	15 April 2011	Chapter 44	Leaflet 44-20	1	15 April 2011
Chapter 34	Leaflet 34-20	14	15 April 2011	Chapter 44	Leaflet 44-20	2	15 April 2011
Chapter 34	Leaflet 34-20	15	15 April 2011	Chapter 44	Leaflet 44-20	3	15 April 2011
Chapter 34	Leaflet 34-20	16	15 April 2011	Chapter 44	Leaflet 44-20	4	15 April 2011
Chapter 34	Leaflet 34-20	17	15 April 2011	Chapter 44	Leaflet 44-30	1	23 Jan 2020
Chapter 34	Leaflet 34-20	18	15 April 2011	Chapter 44	Leaflet 44-30	2	23 Jan 2020
Chapter 34	Leaflet 34-20	19	15 April 2011	Chapter 44	Leaflet 44-30	3	23 Jan 2020
Chapter 34	Leaflet 34-20	20	15 April 2011	Chapter 51	Leaflet 51-10	1	15 April 2011
Chapter 34	Leaflet 34-20	21	15 April 2011	Chapter 51	Leaflet 51-10	2	15 April 2011
Chapter 34	Leaflet 34-30	1	28 February 2017	Chapter 51	Leaflet 51-10	3	15 April 2011
Chapter 34	Leaflet 34-30	2	28 February 2017	Chapter 51	Leaflet 51-10	4	15 April 2011
Chapter 34	Leaflet 34-30	3	28 February 2017	Chapter 51	Leaflet 51-10	5	15 April 2011
Chapter 34	Leaflet 34-40	1	15 April 2011	Chapter 51	Leaflet 51-10	6	15 April 2011
Chapter 34	Leaflet 34-40	2	15 April 2011	Chapter 51	Leaflet 51-10	7	15 April 2011
Chapter 34	Leaflet 34-40	3	15 April 2011	Chapter 51	Leaflet 51-10	8	15 April 2011
Chapter 34	Leaflet 34-40	4	15 April 2011	Chapter 51	Leaflet 51-20	1	15 April 2011
Chapter 34	Leaflet 34-40, Appendix 1	1	15 April 2011	Chapter 51	Leaflet 51-20	2	15 April 2011
Chapter 34	Leaflet 34-40, Appendix 2	1	15 April 2011	Chapter 51	Leaflet 51-30	1	15 April 2011
Chapter 39	Leaflet 39-10	1	15 April 2011	Chapter 51	Leaflet 51-30	2	15 April 2011
Chapter 39	Leaflet 39-10	2	15 April 2011	Chapter 51	Leaflet 51-30	3	15 April 2011
Chapter 39	Leaflet 39-10	3	15 April 2011	Chapter 51	Leaflet 51-30	4	15 April 2011
Chapter 39	Leaflet 39-20	1	15 April 2011	Chapter 51	Leaflet 51-40	1	15 April 2011
Chapter 39	Leaflet 39-20	2	15 April 2011	Chapter 51	Leaflet 51-40	2	15 April 2011
Chapter 39	Leaflet 39-20	3	15 April 2011	Chapter 51	Leaflet 51-40	3	15 April 2011
Chapter 39	Leaflet 39-20	4	15 April 2011	Chapter 51	Leaflet 51-40	4	15 April 2011
Chapter 39	Leaflet 39-20	5	15 April 2011	Chapter 51	Leaflet 51-40	5	15 April 2011
Chapter 39	Leaflet 39-20	6	15 April 2011	Chapter 51	Leaflet 51-40	6	15 April 2011
Chapter 39	Leaflet 39-20	7	15 April 2011	Chapter 51	Leaflet 51-40	7	15 April 2011
Chapter 39	Leaflet 39-20	8	15 April 2011	Chapter 51	Leaflet 51-40	8	15 April 2011
Chapter 39	Leaflet 39-20	9	15 April 2011	Chapter 51	Leaflet 51-50	1	15 April 2011
Chapter 39	Leaflet 39-30	1	15 April 2011	Chapter 51	Leaflet 51-50	2	15 April 2011
Chapter 39	Leaflet 39-30	2	15 April 2011	Chapter 51	Leaflet 51-50	3	15 April 2011
Chapter 39	Leaflet 39-30	3	15 April 2011	Chapter 51	Leaflet 51-50	4	15 April 2011
Chapter 39	Leaflet 39-40	1	15 April 2011	Chapter 51	Leaflet 51-50	5	31 October 2012
Chapter 39	Leaflet 39-40	2	15 April 2011	Chapter 51	Leaflet 51-50	6	15 April 2011

Part	Chapter	Page	Date	Part	Chapter	Page	Date
Chapter 51	Leaflet 51-160	4	15 April 2011	Chapter 61	Leaflet 61-10, Appendix 1	14	15 April 2011
Chapter 51	Leaflet 51-160	5	15 April 2011	Chapter 61	Leaflet 61-10, Appendix 1	15	15 April 2011
Chapter 51	Leaflet 51-160	6	15 April 2011	Chapter 70	Leaflet 70-10	1	15 April 2011
Chapter 51	Leaflet 51-160	7	15 April 2011	Chapter 70	Leaflet 70-10	2	15 April 2011
Chapter 51	Leaflet 51-160	8	15 April 2011	Chapter 70	Leaflet 70-10	3	15 April 2011
Chapter 51	Leaflet 51-160	9	15 April 2011	Chapter 70	Leaflet 70-10	4	15 April 2011
Chapter 51	Leaflet 51-160	10	15 April 2011	Chapter 70	Leaflet 70-10	5	15 April 2011
Chapter 51	Leaflet 51-160	11	15 April 2011	Chapter 70	Leaflet 70-10	6	15 April 2011
Chapter 51	Leaflet 51-160	12	15 April 2011	Chapter 70	Leaflet 70-20	1	15 April 2011
Chapter 51	Leaflet 51-170	1	15 April 2011	Chapter 70	Leaflet 70-20	2	15 April 2011
Chapter 51	Leaflet 51-170	2	15 April 2011	Chapter 70	Leaflet 70-20	3	15 April 2011
Chapter 51	Leaflet 51-170	3	15 April 2011	Chapter 70	Leaflet 70-20	4	15 April 2011
Chapter 51	Leaflet 51-170	4	15 April 2011	Chapter 70	Leaflet 70-20	5	15 April 2011
Chapter 51	Leaflet 51-170	5	15 April 2011	Chapter 70	Leaflet 70-30	1	29 Nov 2013
Chapter 51	Leaflet 51-170	6	15 April 2011	Chapter 70	Leaflet 70-30	2	15 April 2011
Chapter 51	Leaflet 51-170	7	15 April 2011	Chapter 70	Leaflet 70-40	1	29 Nov 2013
Chapter 51	Leaflet 51-170	8	15 April 2011	Chapter 70	Leaflet 70-40	2	29 Nov 2013
Chapter 51	Leaflet 51-170	9	15 April 2011	Chapter 70	Leaflet 70-50	1	15 April 2011
Chapter 51	Leaflet 51-170	10	15 April 2011	Chapter 70	Leaflet 70-50	2	15 April 2011
Chapter 51	Leaflet 51-170	11	15 April 2011	Chapter 70	Leaflet 70-50	3	15 April 2011
Chapter 51	Leaflet 51-170	12	15 April 2011	Chapter 70	Leaflet 70-50	4	15 April 2011
Chapter 51	Leaflet 51-170, Appendix 1	1	30 Nov 2011	Chapter 70	Leaflet 70-50	5	15 April 2011
Chapter 51	Leaflet 51-170, Appendix 1	2	30 Nov 2011	Chapter 70	Leaflet 70-50	6	15 April 2011
Chapter 51	Leaflet 51-170, Appendix 1	3	15 April 2011	Chapter 70	Leaflet 70-50	7	15 April 2011
Chapter 51	Leaflet 51-180	1	15 April 2011	Chapter 70	Leaflet 70-50	8	15 April 2011
Chapter 56	Leaflet 56-10	1	15 April 2011	Chapter 70	Leaflet 70-60	1	15 April 2011
Chapter 56	Leaflet 56-10	2	15 April 2011	Chapter 70	Leaflet 70-60	2	15 April 2011
Chapter 56	Leaflet 56-10	3	15 April 2011	Chapter 70	Leaflet 70-60	3	15 April 2011
Chapter 56	Leaflet 56-10	4	15 April 2011	Chapter 70	Leaflet 70-60	4	15 April 2011
Chapter 56	Leaflet 56-10	5	15 April 2011	Chapter 70	Leaflet 70-60	5	15 April 2011
Chapter 56	Leaflet 56-10	6	15 April 2011	Chapter 70	Leaflet 70-60	6	15 April 2011
Chapter 56	Leaflet 56-10	7	15 April 2011	Chapter 70	Leaflet 70-60	7	15 April 2011
Chapter 56	Leaflet 56-10	8	15 April 2011	Chapter 70	Leaflet 70-60	8	15 April 2011
Chapter 56	Leaflet 56-10	9	15 April 2011	Chapter 70	Leaflet 70-60	9	15 April 2011
Chapter 61	Leaflet 61-10	1	15 April 2011	Chapter 70	Leaflet 70-60	10	15 April 2011
Chapter 61	Leaflet 61-10, Appendix 1	1	15 April 2011	Chapter 70	Leaflet 70-60	11	15 April 2011
Chapter 61	Leaflet 61-10, Appendix 1	2	15 April 2011	Chapter 70	Leaflet 70-60	12	15 April 2011
Chapter 61	Leaflet 61-10, Appendix 1	3	15 April 2011	Chapter 70	Leaflet 70-70	1	15 April 2011
Chapter 61	Leaflet 61-10, Appendix 1	4	15 April 2011	Chapter 70	Leaflet 70-70	2	15 April 2011
Chapter 61	Leaflet 61-10, Appendix 1	5	15 April 2011	Chapter 70	Leaflet 70-70	3	15 April 2011
Chapter 61	Leaflet 61-10, Appendix 1	6	15 April 2011	Chapter 70	Leaflet 70-70	4	15 April 2011
Chapter 61	Leaflet 61-10, Appendix 1	7	15 April 2011	Chapter 70	Leaflet 70-70	5	15 April 2011
Chapter 61	Leaflet 61-10, Appendix 1	8	29 Nov 2013	Chapter 70	Leaflet 70-70	6	15 April 2011
Chapter 61	Leaflet 61-10, Appendix 1	9	31 October 2012	Chapter 70	Leaflet 70-70	7	15 April 2011
Chapter 61	Leaflet 61-10, Appendix 1	10	31 October 2012	Chapter 70	Leaflet 70-70	8	15 April 2011
Chapter 61	Leaflet 61-10, Appendix 1	11	31 October 2012	Chapter 70	Leaflet 70-70	9	15 April 2011
Chapter 61	Leaflet 61-10, Appendix 1	12	15 April 2011	Chapter 70	Leaflet 70-70	10	15 April 2011
Chapter 61	Leaflet 61-10, Appendix 1	13	15 April 2011	Chapter 70	Leaflet 70-70	11	15 April 2011

Part	Chapter	Page	Date	Part	Chapter	Page	Date
Chapter 70	Leaflet 70-80	1	31 October 2012				
Chapter 70	Leaflet 70-80	2	31 October 2012				
Chapter 70	Leaflet 70-80	3	31 October 2012				
Chapter 70	Leaflet 70-80	4	31 October 2012				
Chapter 70	Leaflet 70-80	5	31 October 2012				
Chapter 70	Leaflet 70-80	6	31 October 2012				
Chapter 70	Leaflet 70-80	7	31 October 2012				
Chapter 70	Leaflet 70-80	8	31 October 2012				
Chapter 70	Leaflet 70-90	1	23 Jan 2020				
Chapter 70	Leaflet 70-90	2	23 Jan 2020				
Chapter 70	Leaflet 70-90	3	23 Jan 2020				
Chapter 70	Leaflet 70-90	4	23 Jan 2020				
Chapter 70	Leaflet 70-90	5	23 Jan 2020				
Chapter 70	Leaflet 70-90	6	23 Jan 2020				
Chapter 70	Leaflet 70-90	7	23 Jan 2020				
Chapter 70	Leaflet 70-90, Appendix 1	1	23 Jan 2020				
Chapter 70	Leaflet 70-90, Appendix 1	2	23 Jan 2020				
Chapter 70	Leaflet 70-90, Appendix 1	3	23 Jan 2020				
Chapter 70	Leaflet 70-90, Appendix 1	4	23 Jan 2020				
Chapter 100	Leaflet 100-10	1	15 April 2011				
Chapter 100	Leaflet 100-10	2	15 April 2011				
Chapter 100	Leaflet 100-10	3	15 April 2011				
Chapter 100	Leaflet 100-10	4	15 April 2011				
Chapter 100	Leaflet 100-10	5	15 April 2011				
Chapter 100	Leaflet 100-10	6	15 April 2011				
Chapter 100	Leaflet 100-10	7	15 April 2011				
Chapter 100	Leaflet 100-10, Appendix 1	1	15 April 2011				
Chapter 100	Leaflet 100-10, Appendix 1	2	15 April 2011				
Chapter 100	Leaflet 100-10, Appendix 1	3	15 April 2011				
Chapter 100	Leaflet 100-10, Appendix 1	4	15 April 2011				
Chapter 100	Leaflet 100-10, Appendix 1	5	15 April 2011				

Contents

	List of Effective Pages	iii
	Revision History	1
	Foreword	1
Chapter B	Airworthiness Information	
Leaflet B-20	Aerospace Specifications	
Leaflet B-30	Changes Affecting Design and Production Organisations Appendix 1	
Leaflet B-40	CAA Oversight of Military Registered Aircraft (COMRA) - Policy and Principles Annex A Guidance Material to Support the Return of Military Registered Aircraft Operating Within the Policy Framework of Leaflet B-40 Back onto the Civil Register	
Leaflet B-60	State Aircraft	
Leaflet B-70	Aircraft Insurance	
Leaflet B-80	Civil Aviation Regulation of Light Aircraft used for General Aviation	
Leaflet B-90	Information for Continued Airworthiness of Non-EASA Aircraft Designed in the UK and Elsewhere Appendix 1 Non-EASA Aircraft Types of UK Design having Continued Airworthiness Support provided by a Type Design Organisation Appendix 2 Non-EASA Aircraft Types of UK Design having Continued Airworthiness Monitoring provided by a Type Responsibility Agreement Holder Appendix 3 Non-EASA Aircraft Types of UK Design having Continued Airworthiness Monitoring provided by the CAA Appendix 4 British-Registered Non-EASA Aircraft Types of Foreign Design having Continued Airworthiness Monitoring provided by a UK Type Responsibility Agreement Holder	

Leaflet B-100	Acceptance Standards for Imported Aircraft for which a UK National Certificate of Airworthiness is Sought
Leaflet B-110	The Acceptance of Aircraft Components
Leaflet B-120	Use of Standard Parts in Aircraft and Aircraft Restoration Projects
Leaflet B-130	The Problem of Bogus Parts
Leaflet B-140	UK Certificate of Airworthiness Issue for Series Aircraft at the Manufacturer's Premises in the USA Appendix 1 Appendix 2
Leaflet B-150	Safety Critical Maintenance Tasks
Leaflet B-160	Maintenance Error Management Systems
Leaflet B-170	CAA Use of Confidential Information
Leaflet B-180	Experience from Incidents
Leaflet B-190	Carbon Monoxide Contamination
Leaflet B-200	Compact Disc – Read Only Memory (CD-ROM) Technical Library
Leaflet B-210	Disposition of Scrap Aircraft Parts and Materials
Leaflet B-220	Return to Service of Aircraft Items Recovered from Aircraft Involved in Accidents/Incidents
Leaflet B-230	Overhauls, Modifications, Repairs and Replacements to Aircraft not Exceeding 2730 kg with a National Certificate of Airworthiness in the Special Category
Leaflet B-240	Aerobatic Manoeuvres
Leaflet B-250	Chipmunk Spinning and Aerobatics

Chapter C Airworthiness Procedures

Leaflet C-20	Approval of Organisations Appendix 1 Subcontracting to Non-Approved Organisations Appendix 2 Acceptable Data for use by Part M Subpart F Organisations, Part-145 Organisations and Independent Part-66 Certifying Staff
Leaflet C-30	CAA Approvals – Non Transferability
Leaflet C-40	CAA recognition of Test Houses Holding United Kingdom Accreditation Service (UKAS) Accreditation Appendix 1
Leaflet C-50	UK Certification of Aircraft which are Eligible for the Issue of an EASA or UK National Certificate of Airworthiness Appendix 1 Reference Documents Appendix 2 Typical Survey Items Appendix 3 Operation of the Aircraft
Leaflet C-60	Issue of an EASA Permit to Fly to UK Registered Aircraft Temporarily Unable to Hold a Certificate of Airworthiness or Restricted Certificate of Airworthiness

Leaflet C-70	Issue of a Certificate of Airworthiness for Duplicate Sailplanes in accordance with Regulation (EC) No. 216/2008
Leaflet C-80	Steep Approaches
Leaflet C-90	Computer Control – Records and Programmes
Leaflet C-100	Radio Apparatus for use in Aircraft for other than Flight Operational Purposes
Leaflet C-110	A Simplified Means of Approval for Airframe Structural Repairs Design
Leaflet C-120	Restoration, Airworthiness Control and Maintenance of Aircraft of Ex-military Origin under a BCAR Chapter A8-20 Approval Appendix 1 Appendix 2
Leaflet C-130	Sailplane Repairs in accordance with Regulation (EC) No. 216/2008
Leaflet C-140	The Rebuilding and Restoration of Aircraft
Leaflet C-150	Applications for the Approval of CAA Supplemental Type Certificates Appendix 1 CAA Application Form Appendix 2 STC Definition Document Appendix 3 Guidance for Compilation of Certification Documents Appendix 4 Example Supplemental Type Certificate
Leaflet C-160	Continuing Airworthiness Responsibilities for Owners/Operators of Aircraft with an EASA Certificate of Airworthiness not used for Commercial Air Transport
Leaflet C-170	EASA Aircraft with an Expired UK (National) Certificate of Airworthiness
Leaflet C-180	Control of Production Suppliers and Subcontractors

Chapter D Engineering Practices and Processes

Leaflet D-10	Engineering Drawings
Leaflet D-20	Measurement and Calibration Systems
Leaflet D-30	Clean Rooms
Leaflet D-40	Storage Conditions For Aeronautical Supplies

Chapter E Identification Marking

Leaflet E-10	Identification Marking Processes for Aircraft Parts
Leaflet E-20	Identification Markings on Metallic Materials
Leaflet E-30	Bolts and Screws of British Manufacture
Leaflet E-40	Standard Fasteners of American Manufacture

Chapter F Non-destructive Examinations

Leaflet F-10	Oil and Chalk Processes
Leaflet F-20	Penetrant Dye Processes
Leaflet F-30	Fluorescent Penetrant Processes
Leaflet F-40	Performance Testing of Penetrant Testing Materials

Leaflet F-50	Ultrasonic Flaw Detection and Thickness Measurement
Leaflet F-60	Radiological Examination of Aircraft Structures
Leaflet F-70	Magnetic Flaw Detection
Leaflet F-80	Eddy Current Methods
Leaflet F-90	Endoscope Inspections

Chapter G Ground Operations

Leaflet G-10	Aircraft Handling
Leaflet G-20	Fire – General Precautions

Chapter H Maintenance Personnel Licensing

Leaflet H-10	Aircraft Maintenance Engineers Licensing – General Licensing Information
Leaflet H-20	Licensed Aircraft Maintenance Personnel – Certification Responsibilities of Type Rated/Authorised Personnel
Leaflet H-30	Aircraft Maintenance Engineers Licences – Type Ratings
Leaflet H-40	Personnel Authorisation Systems for Sailplanes and Balloon Certifying Staff in Part M Subpart F Organisations
Leaflet H-50	Implementation of the Railways and Transport Safety Act 2003 – Aviation: Alcohol and Drugs
Leaflet H-60	Licensed Aircraft Maintenance Engineers – Personal Responsibility When Medically Unfit or Under the Influence of Drink or Drugs
	Appendix 1

Book 2 – Technical Subjects (by ATA Chapter Number)

Chapter 5	Time Limits / Maintenance Checks
Leaflet 5-10	Maintenance Schedules and Programmes – A Guide to Compilation and Development
Leaflet 5-20	Standard Maintenance Practices – Introduction
Leaflet 5-30	Standard Clauses for Insertion in Maintenance Schedule Introductory Pages Appendix A
Leaflet 5-40	Maintenance of Aircraft not Operated for Commercial Air Transport
Leaflet 5-50	Approval of Maintenance Schedules For Aircraft Above 2730 kg MTWA not Operated for Commercial Air Transport
Leaflet 5-60	Condition Monitored Maintenance
Leaflet 5-70	Aircraft, Engine and Propeller Log Books
Chapter 8	Weighing
Leaflet 8-10	Weight and Balance of Aircraft
Chapter 12	Servicing – Routine Maintenance
Leaflet 12-10	Cleanliness of Aircraft
Chapter 20	Standard Practices – Airframe
Leaflet 20-10	Torque Loading
Leaflet 20-20	Thread Inserts
Leaflet 20-30	Cable – Splicing and Swaging
Leaflet 20-40	Control Chains, Chain Wheels and Pulleys
Leaflet 20-50	Hose and Hose Assemblies
Leaflet 20-60	Installation and Maintenance of Rigid Pipes
Leaflet 20-70	High Pressure Pneumatic System
Leaflet 20-80	Control Systems
Chapter 24	Electrical Power
Leaflet 24-10	Charging Rooms for Aircraft Batteries
Leaflet 24-20	Nickel Cadmium Batteries
Leaflet 24-30	Electrical Generation Systems – Multi-Engined Aircraft not Exceeding 5700 kg Maximum Authorised Weight
Leaflet 24-40	Aircraft Electrical Load and Power Source Capacity Analysis
Leaflet 24-50	Electrical Generation Systems – Bus-Bar Low Voltage Warning Single- Engined Aircraft With A UK Certificate of Airworthiness

Chapter 25	Equipment/Furnishings
Leaflet 25-10	Lifejackets
Leaflet 25-20	Use of Electrically Powered Medical Equipment on Aircraft
Leaflet 25-30	Electrically Powered Aeroplane Passenger Seats
Leaflet 25-40	Maintenance and Inspection of Crew Harnesses and Passenger Seat Belts (Metal to Metal Attachment) Appendix1SafetyBelts
Leaflet 25-50	N15F210B Underwater Locating Beacon
Leaflet 25-60	Guidance on Testing Emergency Locator Transmitters (ELTs) Appendix1SystemDescriptionandOperation
Leaflet 25-70	Portable Battery Powered Megaphones
Leaflet 25-80	Demonstrating Compliance with CAT.GEN.MPA.140 and ANO Article 119(4A) when Carrying Personnel Locator Beacons
Leaflet 25-90	Minimum Space for Seated Passengers
Leaflet 25-100	Access to and Opening of Type III and Type IV Emergency Exits
Leaflet 25-110	Flame Resistant Furnishing Materials
Leaflet 25-120	Improved Flammability Test Standards for Cabin Interior Materials
Leaflet 25-130	Fire Precautions – Aircraft Toilets
Chapter 28	Fuel
Leaflet 28-10	Microbiological Contamination of Fuel Tanks of Turbine Engined Aircraft
Leaflet 28-20	The Use of Motor Gasoline (Mogas) and Unleaded Aviation Gasoline (Avgas) UL 91
Chapter 31	Indicating/Recording Systems
Leaflet 31-10	Cockpit Voice Recorder System Fairchild A100 Series
Chapter 32	Landing Gear
Leaflet 32-10	Tyres
Leaflet 32-20	Wheels and Brakes
Leaflet 32-30	Tyre Wear Limitations
Chapter 33	Lights
Leaflet 33-10	Emergency Floor Path Lighting System
Leaflet 33-20	Installation of High Intensity Strobe Lights (HISL) on Helicopters
Chapter 34	Navigation
Leaflet 34-10	Compass Base Surveying
Leaflet 34-20	Compasses
Leaflet 34-30	Radio Altimeters and AVADs for Helicopters
Leaflet 34-40	Certification and Installation of ACAS 1 Equipment and Other Similar Non-Mandatory Aircraft Collision Avoidance Systems

Chapter 39 Electrical-Electronic Components and Multifunction Units

- Leaflet 39-10 The Selection and Procurement of Electronic Components
- Leaflet 39-20 Antistatic Protection
- Leaflet 39-30 Protection from the Effects of HIRF (High Intensity Radiated Fields) associated with Aircraft Modifications
- Leaflet 39-40 Lightning Strike Hazards on Light Aeroplanes and Gliders

Chapter 44 Cabin Systems

- Leaflet 44-10 Continuing Airworthiness and Safety Standards of Passenger Service and In-Flight Entertainment Systems
Appendix 1 Guidance on the Development of IFE Scheduled Maintenance Tasks and Solutions
- Leaflet 44-20 Aircraft Security, Flight Crew Compartment Monitoring Systems
- Leaflet 44-30 Helicopter Emergency Escape Facilities

Chapter 51 Standard Practices and Structures – General

- Leaflet 51-10 Inspection of Wooden Structures
- Leaflet 51-20 Deterioration of Wooden Aircraft Structures
- Leaflet 51-30 Timber Conversion – Spruce
- Leaflet 51-40 Synthetic Resin Adhesives
- Leaflet 51-50 Inspection of Metal Aircraft Structures
- Leaflet 51-60 Corrosion of Aircraft Structures
- Leaflet 51-70 Inspection of Metal Aircraft After Abnormal Occurrences
- Leaflet 51-80 Fatigue Lives
- Leaflet 51-90 Repair of Metal Airframes
- Leaflet 51-100 Locking and Retaining Devices
- Leaflet 51-110 Assembly and Maintenance of Critical Bolted Joints
- Leaflet 51-120 Rigging Checks on Aircraft
- Leaflet 51-130 The Effect of Disturbed Airflow on Aeroplane Behaviour
- Leaflet 51-140 Paint Finishing of Metal Aircraft
- Leaflet 51-150 Fabric Covering
- Leaflet 51-160 Doping
- Leaflet 51-170 Inspection of Composite Structures
Appendix 1 Further NDT Techniques
- Leaflet 51-180 Structural Attachment of Aerials

Chapter 56 Windows

- Leaflet 56-10 Glass Windscreen Assemblies

Chapter 61 Propellers/Propulsors

- Leaflet 61-10 Propellers Approved for use on Civil Aircraft Manufactured in the United Kingdom
Appendix 1

Chapter 70 Engines

- Leaflet 70-10 Storage Procedures – General Guidance
- Leaflet 70-20 The Process for Acceptance of Used Engines, Engine Modules, Auxiliary Power Units (APUs) and Propellers for Use on NON-EASA Aircraft Requiring a UK Certificate of Airworthiness
- Leaflet 70-30 Acceptance of Ex-UK Government Gipsy Major 8 Engines and Fixed Pitch Fairey Reed Metal Propellers
- Leaflet 70-40 Acceptance of Ex-UK Government Lycoming IO 360-A1B6 Engines and Variable Pitch Propellers
- Leaflet 70-50 Piston Engine Overhaul – Dynamometer Testing of Overhauled Engines
- Leaflet 70-60 Piston Engine Overhaul – Fan Testing of Overhauled Engines
- Leaflet 70-70 Piston Engine Overhaul – Correcting Engine Test Results
- Leaflet 70-80 Guidance Material for Ageing Engine Continuing Airworthiness
- Leaflet 70-90 Guidance Material for Power by the Hour Agreements in the Continuing Airworthiness Management Environment
Appendix 1 Owner/Operator Checklist Considerations in a Power By The Hour Environment

Chapter 100 Computer Hardware-Software

- Leaflet 100-10 Aircraft Field Loadable Software (FLS) and Database Field Loadable Data (DFLD)
Appendix 1 FLS and DFLD Control, Tooling and Loading

Revision History

Issue 3

15 April 2011

CAP 562 has been restructured and re-numbered; Leaflets are now contained in two books. Book 1 contains CAA information and procedures in eight chapters labelled alphabetically, with the Leaflets within each chapter labelled alphanumerically. Book 2 contains information on technical subjects organised in 18 chapters according to the ATA 100 chapter numbering system.

The following new Leaflets are published:

Leaflets 25-80, C-160 and C-170 (previously issued as Airworthiness Communications, AIRCOMs).

New Appendix 3 to Leaflet A-20 has been published to reflect changes in the numbering system of the Leaflets.

Leaflet 4-10 and its Appendix 1 have been cancelled.

The following Leaflets have been significantly amended:

Leaflet B-10, B-40 and its Appendix, B-60, C-60, H-10 and its Appendix, H-60 and its Appendix.

Appendices 1, 2 and 3 to Leaflet B-90 have been updated to include in the listing the addresses of Responsible Organisations for Non-EASA Aircraft Types of UK Manufacture.

Further editorial changes and minor technical amendments convenient to be included at this time have also been incorporated.

Issue 3 (corrected)

13 May 2011

This correction to CAP 562 reflects the removal of Leaflet C-60 Appendices 1 and 2 which have become obsolete and the consequent update to Leaflet A-20, Appendix 3. Also, a typographical error has been corrected in Chapter B, Leaflet B-10, paragraph 4.3.

Issue 3, Amendment 1

30 November 2011

Appendix 2 to Leaflet A-20 has been updated to include new numbering system in the list of current Leaflets, previously listed as Airworthiness Notices, for clarity and the ease of search and to make it compatible with Appendix 3 of 'Renumbered Leaflets'.

The following existing Leaflets have been technically amended:

Leaflet B-40 and Appendix 1, Leaflet B-50, Leaflet B-60, Leaflet B-90 and Appendices 1-3 and Leaflet C-60.

New Appendix 4 to Leaflet B-90, has been added to extend the list of non-EASA Aircraft types for Continued Airworthiness to British registered non-EASA Aircraft types of foreign design having Continued Airworthiness monitoring provided by a UK type responsibility agreement holder.

The following existing Leaflets and Appendices contain editorial changes, corrections and amendments convenient to be included at this time:

Leaflets A-10, A-20 and its Appendix 1, B-250 and C-20 in Book 1.

Leaflet 5-50 and Appendix 1 to Leaflet 51-170 in Book 2.

NOTE: The abbreviation for Ministry of Defence – MoD, has been amended to read MOD throughout the text.

Leaflet C-10 has been deleted as its content is duplicated in CAP 382.

Issue 3, Amendment 2**31 October 2012**

Leaflet B-160 has been technically revised and the new version has been incorporated into CAP 562, replacing the existing leaflet.

New Leaflet C-180, entitled Control of Production Suppliers and Subcontractors, has been added to CAP 562 to define a clear and common procedure applicable to CAA approved production organisations and their facilities/partners/suppliers and subcontractors located in the UK or in another country on the basis of Part 21.

New Leaflet 28-20, entitled The Use of Motor Gasoline (Mogas) and Unleaded Aviation Gasoline (Avgas) UL 91, has been added to inform all owners and operators of aircraft powered by spark-ignition piston engines about the use of Mogas and Avgas UL 91, and to provide guidance on the content of fuel related Generic Concessions and information on how to seek approval of Mogas or UL 91.

New Leaflet 70-80, entitled Guidance Material for Ageing Engine Continuing Airworthiness, has been added to provide continuing airworthiness recommendations for the management of engines against potential time related deterioration. This guidance material was produced following a number of accidents over a period, involving the serious failure of high calendar time engines or their accessories.

New Leaflet 70-90, entitled Guidance Material for Component Hourly Usage Agreements in the Continuing Airworthiness Management Environment, and its Appendix 1, has been added to highlight the considerations necessary for the continuing airworthiness management of airframes, engines, propellers and components in the environment of Hourly Usage Agreements (HUAs), particularly relevant to large transport aircraft and rotorcraft, managed under EASA Part-M Subpart G CAMOs and operating in CAT environments.

The following Leaflets have been revised and technically amended:

- Leaflet A-20 and its Appendix 1; Appendices 1 and 2 to Leaflet B-90; Appendices 25-6, 27-3, 32-2, 33-1, 35-2, 51-6, 72-1 to Leaflet B-180; Leaflet B-210; Leaflet C-90; Leaflet H-10; Leaflet H-20 and Leaflet H-30 in Book 1.
- Leaflets 51-50; 51-90; 51-100; and Appendix 1 to Leaflet 61-10 in Book 2.

The following existing Leaflet contains editorial changes, corrections and amendments convenient to be included at this time:

- Leaflet D-20 in Book 1.

Issue 3, Amendment 3**29 November 2013**

Leaflet B-50 has been deleted as all its information is contained in the new CAP 1038 'CAA Check Flight Handbook', published on 29 November 2013.

Leaflet B-60 has been revised to reflect the last amendment to the Air Navigation Order and the change of policy regarding CAA requirements for check flights announced on 1 July 2013 in Safety Notice SN-2013/011.

The following Leaflets have been revised and technically amended:

- B-90 Appendix 2 and C-60 in Book 1;
- 61-10 Appendix 1, Leaflet 70-30 and 70-40 in Book 2.

Further editorial changes and minor technical amendments to Leaflet A-20 and its Appendices 1 and 3, convenient to be included at this time have also been incorporated.

Issue 4**22 March 2016**

Leaflets A.10, B.40 and C.180 have been updated. Leaflets 25-90, 25-100, 25-110, 25-120 and 25-130 have been added. The content of these leaflets was previously published as Generic Requirements in CAP 747. Leaflets A.20 and B.10 have been deleted.

Issue 4, Amendment 1**28 February 2017**

Leaflet B-180, Appendix 1-2 has been replaced in its entirety and Leaflet 34-30 has been technically updated.

Issue 4, Amendment 2**15 December 2017**

Leaflet B-40 'CAA Oversight of Military Registered Aircraft – Policy and Principles' has been updated to reflect changes, and provide greater clarity, regarding the approval of modifications to military registered aircraft subject to CAA oversight.

Issue 4, Amendment 3**23 January 2020**

Leaflet A-10 'Contact Details' has been removed as it was no longer up to date. All current contact details can be found on the CAA website.

Leaflet B-40 'CAA Oversight of Military Registered Aircraft – Policy and Principles' has been updated and a new Annex A added to provide Guidance Material to support the return of military registered aircraft operating within the framework of Leaflet B-40 back onto the civil register. The previous Appendix 1 entitled 'Explanation of the Legal Framework' has been removed completely as the contents are now out of date.

The following four Leaflets have also been updated:

- Leaflet B-180 "Experience from Incidents", Appendix 1-2: The Consignment by Air of Aircraft Spares and Consumables which meet the Criteria of 'Dangerous Goods'.
- Leaflet 25-80 "Demonstrating Compliance with CAT.GEN.MPA.140 and ANO Article 119(4A) when Carrying Personnel Locator Beacons".
- Leaflet 44-30 "Helicopter Emergency Escape Facilities".
- Leaflet 70-90 "Guidance Material for Power by the Hour Agreements in the Continuing Airworthiness Management Environment".

It is appreciated that several other documents in this CAP are also in need of an update. This will be undertaken when the outcome of Brexit is more certain.

Foreword

1 Introduction

- 1.1 Civil Aircraft Airworthiness Information and Procedures (CAAIP), hereinafter referred to as the Leaflets are published by the Civil Aviation Authority (CAA). The Leaflets give information on a variety of matters concerned with civil aircraft during manufacture, overhaul, repair, maintenance, operation and procedures. Leaflets may assist and increase the knowledge of the reader on subjects for which there is a shortage of information from other sources.
- 1.2 The information is essentially of a general nature which does not include detail on specific types of aircraft and engines, specialised equipment and component parts fitted to civil aircraft. Manuals, published by the appropriate manufacturers, should be consulted for detailed information.
- 1.3 The interpretation of the Leaflets and the application of the information is greatly dependent on the background knowledge of the reader. In preparing the Leaflets it is assumed that the reader is familiar with the general engineering practices and working procedures of the civil aircraft industry. Nevertheless, a certain amount of background information is provided where this is considered necessary for the understanding of the text.
- 1.4 Words purporting the masculine gender include the feminine.

2 Editorial Presentation

- 2.1 A General Information Leaflet which includes Contact Details and other non-specific information precedes the remaining Leaflets.
- 2.2 The Leaflets are presented as numbered Leaflets contained in two Books and 26 separate chapters.

Book 1 contains CAA information and procedures in eight chapters labelled alphabetically, with the Leaflets within each chapter labelled alphanumerically.

Book 2 contains information on technical subjects in 18 chapters organised according to the Air Transport Association of America Specification 100 (ATA 100) chapter numbering system.
- 2.3 A list of all the Leaflets is given in the Contents.
- 2.4 A system of progressive paragraph numbering is used, the number of digits being kept to a maximum of three by associating the system with paragraph headings. A paragraph heading applies to all succeeding paragraphs until another titled paragraph with the same, or a smaller number of digits occurs.

3 Amendments

Leaflets are reviewed periodically to ensure that the information contained in them remains valid. Each page is identified by the date of issue or date at which it is amended. Where text has over-flowed, the affected pages are identified by the date of re-issue. Information giving details of a particular amendment can be found in the Revision History.

4 Enquiries

Any enquiries regarding the technical content of the Leaflets should be addressed to:

Future Safety - Airworthiness Policy
Civil Aviation Authority
Safety and Airspace Regulation Group
Aviation House
Beehive Ring Road
Crawley
West Sussex
RH6 0YR

Email: FSTechnicalSupportTeam@caa.co.uk

In countries other than the United Kingdom, the airworthiness authority of the country concerned should be approached in all cases where it is recommended in the Leaflets that the CAA should be consulted.

5 Copyright

Civil Aircraft Airworthiness Information and Procedures are copyright and may not be reproduced without permission of the CAA.

INTENTIONALLY LEFT BLANK

Chapter B Airworthiness Information

Leaflet B-20 Aerospace Specifications

1 Introduction

- 1.1 Materials used in aircraft parts affected by airworthiness requirements should conform to approved material specifications. For this purpose, in addition to specifications specifically approved by the CAA (see paragraph 5), British Standard Specifications in the Aerospace Series, issued by the British Standards Institution (BSI) are accepted as approved, and are obtainable from:

British Standards Institution
Standard Enquiries
389 Chiswick High Road
London, W4 5AL
Telephone: (0208) 996 9000

- 1.2 Unless otherwise stated, reference to any specification referred to in this publication implies the latest issue including any amendments.

2 DTD Specifications are prepared by the:

Materials and Structures Department
Royal Aircraft Establishment
Farnborough

3 DTD and DEF Specifications are published and obtainable from:

TSO (The Stationary Office)
(Mail and Telephone orders only)
389 Chiswick High Road
P O Box 29
Norwich NR3 1GN
Telephone (0844) 477 7300

4 Defence Standards are published and obtainable from:

Directorate of Standardisation
Stan 13
Ministry of Defence
Montrose House
187 George Street
Glasgow G1 1YU

5 Specifications Approved by the CAA

5.1 Specifications prepared for a material by an Approved Design Organisation where the material is to be used in a part designed within the terms of the design approval should be submitted in duplicate for approval to the:

Civil Aviation Authority
Safety Regulation Group
Aviation House
Gatwick Airport South
West Sussex RH6 0YR

5.2 A specification submitted for approval should, according to the material concerned, include such of the following information as appropriate:

- a) An identity or reference number, issue number and date.
- b) A title describing the material.
- c) The quality and/or chemical composition of the material.
- d) The mechanical and/or physical properties of the material.
- e) The method of determining the mechanical and/or physical properties of the material.
- f) Particulars of defects which render the material unsuitable.
- g) Particulars of heat treatment and/or other manufacturing processes.
- h) A table of manufacturing tolerances.
- i) Particulars of such markings which will ensure identification of the material.

5.2.1 A specification will be approved if the CAA accept that the material complies with such a specification having the essential properties assumed by the design in the associated technical investigation.

6 CAA Airworthiness Specifications

The following specifications are available from the CAA web site at www.caa.co.uk under the Publications section. Paper copies are available from the CAA's printers whose details are given on the inside cover of this publication.

No. 1	Safety Belts	Issue 6	12 March 2004
No. 2	Inflatable Liferrafts	Issue 2	1 November 1985
No. 5	Inflatable Lifejackets	Issue 2	23 November 1979
No. 9	Child's Flotation Cot	Issue 1	9 April 1957
No. 10	Flight Data Recorder Systems	Issue 1	1 May 1974
No. 10A	Flight Data Recorder for Aeroplane Accidents Investigation	Issue 1	1 June 1990
No. 11	Cockpit Voice Recorder Systems	Issue 3	13 August 1983
No. 12	Underwater Sonar Location Devices Approval, Installation and Maintenance	Issue 1	1 May 1974

No. 14	Ground Proximity Warning Systems	Issue 2	September 1976
No. 15	Public Address Systems	Issue 1	27 January 1989
No. 16	Automatically Deployable Emergency Locator Transmitters for Helicopters	Issue 2	1 December 1991
No. 17	Aeroplane Wheels and Wheel-Brake Assemblies – Minimum Performance Standards	Issue 1	18 September 1986
No. 18	Flight Data Recorder for Helicopter Accidents Investigation	Issue 1	1 June 1990
No. 19	Helicopter Crew Members Immersion Suits	Issue 1	15 April 1991
No. 21	Helicopter Public Address Systems	Issue 1	23 March 1998
No. 22	Global Positioning Systems (GPS) for Use in Rotorcraft for En-Route Navigation	Issue 1	25 April 2005

INTENTIONALLY LEFT BLANK

Leaflet B-30 Changes Affecting Design and Production Organisations

1 Purpose

- 1.1 To provide information to Design and Production Organisations regarding changes caused by the European Regulations that came into force on 28 September 2003, particularly:
- requirements for organisation approvals for design and production activities not subject to European Regulation (EC) No. 216/2008; and
 - flight-testing required by Part-21.

2 Applicability

- 2.1 Design and Production Organisations.
- 2.2 Organisations required to conduct flight tests required by Part-21.

3 Introduction

- 3.1 The European Aviation Safety Agency (EASA) as established in European Regulation (EC) No. 216/2008 commenced operation on 28 September 2003 and at the same time European Commission Regulation (EC) No. 1702/2003, laying down implementing rules for the airworthiness and certification of aircraft, entered into force. These regulations and implementing rules have affected the organisation approval requirements for design and production organisations currently approved to BCAR Sub-Section A8.

- NOTES:**
- 1)** For the purposes of this Leaflet, aircraft that are required to comply with Regulation (EC) No. 216/2008 are specified as "EASA Aircraft".
 - 2)** For the purposes of this Leaflet, aircraft that are not required to comply with Regulation (EC) No. 216/2008 are specified as "Non-EASA Aircraft".
 - 3)** Lists of EASA and Non-EASA aircraft can be found in CAP 747.

4 Effectivity

This Leaflet is effective from 28 September 2004.

5 Requirements

5.1 Design – EASA aircraft

All design changes, repair design and initial design associated with EASA aircraft must be in accordance with Part-21 and approved either by EASA or by an appropriately approved Part-21 Subpart J design organisation.

NOTE: Even if an aircraft is being used as a 'state aircraft' and is therefore not the responsibility of EASA, a design change to that aircraft could still be approved through the EASA system. If the design change is a series modification and applicable to aircraft covered by the TC it is not state specific and could be accepted as an EASA design change. Alternatively, the design change could be defined as aircraft specific which would make it applicable to the 'state aircraft' only and would allow it to be approved under the national system as below.

5.2 Design – Non-EASA aircraft

Design changes, repair design and initial design not eligible for approval under Part-21 are a national responsibility and are approved by the CAA, an appropriately approved BCAR design organisation or a Part-21 approved design organisation with an appropriate supplement to their EASA approval issued by the CAA. A Part-21 DOA requiring the ability to perform design activity in accordance with the national system, rather than to Part-21, can apply to the CAA for this supplement.

Examples of design not eligible for approval under Part-21 are:

- a) Annex II aircraft design changes or repair design; and
- b) Modification of an aircraft with an EASA TC but used for state purposes (e.g. police) where the design change is not certifiable as an EASA design change. If a design change to a state aircraft can be approved through Part-21, as described above, it is advisable to do this as any design change or repair not approved under Part-21 precludes the issuance of an EASA Certificate of Airworthiness for the affected aircraft. If at a later date the aircraft is not used for state purposes all non-EASA design changes will need removal or approving under the EASA system before the EASA Certificate of Airworthiness could be granted.

5.3 Production – EASA aircraft

Production against EASA approved design data needs to be in accordance with Part-21 and may be released on an EASA Form 1 by a Subpart G approved production organisation (POA) or an organisation working in accordance with Subpart F. Release on a JAA Form One has not been appropriate in the UK since 28 September 2005.

5.4 Production – Non-EASA aircraft

If the design data has been approved under the CAA national system and not under the EASA system then release on an EASA Form 1 is not appropriate. An organisation with an appropriate BCAR approval or a Part-21 POA with an appropriate CAA supplement can release on a CAA Approved Certificate as described in Appendix 1 to this Leaflet. Release on a JAA Form One has not been appropriate in the UK since 28 September 2005.

5.5 Information on the future requirements for organisation approvals for design and production activities on Non-EASA aircraft

Organisations whose activity is only related to Non-EASA aircraft may continue to use their BCAR Section A8 approvals. The CAA has replaced these national requirements with a set of common requirements based upon Part-21. These requirements are published as BCAR Chapter A8-21 and have been developed with industry support.

5.6 Flight testing required by Part-21

NOTES: 1) For EASA aircraft the CAA were responsible for making the findings associated with the issue of a Permit to Fly until 28 March 2007 in accordance with Regulation (EC) No. 1702/2003 Article 2, paragraph 11.

EU regulation 375/2007 was published on the 4 April 2007 and introduced EASA requirements for flight testing into Part-21. CAP 562 Leaflet C-60 provides guidance on the new rules and the associated processes for application, approval and issue of EASA Permits to Fly.

- 2)** For Non-EASA aircraft the requirements of BCAR Chapter A3-8 (A Conditions) and Chapter A3-9 (B Conditions) are still applicable and an organisation approval in accordance with BCAR Chapter A8-9 is required as necessary.

Appendix 1

1 United Kingdom Civil Aviation Authority		UK CAA APPROVED CERTIFICATE				3 Form Tracking Number	
4 Approved Organisation Name and Address					5 Work Order / Contract / Invoice		
6 Item	7 Description	8 Part No.	9 Eligibility*	10 Qty	11 Serial No / Batch No	12 Status/Work	
13 Remarks							
This certificate has been issued under national rule provisions							
14 Certifies that, unless otherwise specified in block 13, the items identified above were manufactured in conformity to: <input type="checkbox"/> approved design data and are in a condition for safe operation <input type="checkbox"/> non-approved design data specified in block 13				19 Certifies that unless otherwise specified in block 13 the work identified in block 12 and described in block 13 was accomplished in accordance with the airworthiness requirements of the UK and in respect to that work the items are considered ready for release to service			
15 Authorised Signature		16 Approval No.		20 Authorised Signature		21 Approval No.	
17 Name		18 Date (dd/mmm/yyyy)		22 Name		23 Date (dd/mmm/yyyy)	

* Installer must cross-check eligibility with applicable technical data

USER/INSTALLER RESPONSIBILITIES

NOTES: 1. It is important to understand that the existence of the document alone does not automatically constitute authority to install the part/component/assembly.

2. Where the user/installer works in accordance with the national regulations of another airworthiness authority it is essential that the user/installer ensure that his/her airworthiness authority accepts parts/components/assemblies from the UK CAA.

3. Statement 14 and 19 do not constitute installation certification. In all cases the aircraft maintenance record shall contain an installation certification issued in accordance with the national regulations by the user/installer before the aircraft may be flown.

APPROVED CERTIFICATE COMPLETION INSTRUCTIONS

These instructions relate only to the use of the UK CAA Approved Certificate for manufacturing purposes.

1 Purpose and Scope

The primary purpose of the certificate is to release products, parts and appliances (hereafter referred to as 'item(s)') as identified in Blocks 7 through 11 as applicable after manufacture, or to release maintenance work carried out on items under the approval of the CAA.

The Certificate serves as an official certificate for the delivery of items from the manufacturer to users. The Certificate is not, however, a delivery or shipping note.

It may only be issued by organisations certificated by the CAA, within the scope of such an approval. Aircraft are not to be released using the Certificate. Products, Parts or Appliances for aircraft that are the responsibility of the European Aviation Safety Agency (EASA) are NOT to be released using the Certificate.

A mixture of 'New' and 'Used' items is not permitted on the same Certificate.

A mixture of items certified in conformity with 'approved data' and to 'non-approved data' is not permitted on the same Certificate, and consequently only one box in Block 14 can be ticked.

2 General

The Certificate must comply with the format attached including block numbers and the location of each Block. The size of each Block may however be varied to suit the individual application, but not to the extent that would make the Certificate unrecognisable. The overall size of the Certificate may be significantly increased or decreased so long as the Certificate remains recognisable and legible. The Certificate must be in 'Portrait' rather than 'Landscape' to help differentiate it from the EASA Form 1. If in doubt consult the CAA.

Please note that the user responsibility statements can be placed on either the reverse or front of this Certificate.

All printing must be clear and legible to permit easy reading and be in English.

The Certificate may either be pre-printed or computer generated but in either case the printing of lines and characters must be clear and legible. Pre-printed wording is permitted in accordance with the attached model but no other certification statements are permitted.

The details entered onto the Certificate must be in English and permit easy reading, and may be entered by hand, using block letters, or by a machine or computer. Abbreviations must be restricted to a minimum.

The space remaining on the reverse side of the Certificate may be used by the originator for any additional information but must not include any certification statement.

The original Certificate must accompany the items and correlation must be established between the Certificate and the item(s). A copy of the Certificate must be retained by the organisation that manufactured the item. Where the Certificate format and the data is entirely computer generated, subject to acceptance by the CAA, it is permissible to retain the Certificate format and data on a secure database.

There is no restriction in the number of copies of the Certificate sent to the customer or retained by the originator.

The Certificate that accompanies the item may be attached to the item by being placed in an envelope for durability.

3 Completion of the Approved Certificate by the Originator

Except as otherwise stated, there must be an entry in all Blocks to make the document a valid certificate.

- | | |
|---------|--|
| Block 1 | Pre-printed 'United Kingdom Civil Aviation Authority'. |
| Block 2 | Pre-printed 'UK CAA Approved Certificate'. |
| Block 3 | A unique number must be pre-printed in this Block for Certificate control and traceability purposes except that in the case of a computer generated document, the unique number need not be pre-printed where the computer is programmed to produce the number. |
| Block 4 | <p>The information in this Block needs to satisfy two objectives:</p> <ol style="list-style-type: none"> 1 to relate the Certificate to an organisation approval, for the purposes of verifying authenticity and authority of the Certificate; 2 to provide a ready means of rapidly identifying the place of manufacture and release, to facilitate traceability and communication in the event of problems or queries. <p>Therefore, the name entered in the box is that of the organisation approval holder who is responsible for making the final determination of conformity or airworthiness, and whose Approval Reference Number is quoted in Block 16. The name must be entered in exactly the same form as appears in the Approval Certificate held by the organisation.</p> <p>The address(es) entered in Block 4 will assist in the identification of the approval holder and in identifying the place of release.</p> <p>If the place of manufacture and release is one of the organisation addresses listed on the Approval Certificate, then that is the only address needed in this Block.</p> <p>If the place of manufacture and release is a location which is NOT listed in the Approval Certificate then two addresses are required. The first address will be the address of the approval holder (as listed in the Approval Certificate) and a second address entered to identify the place of manufacture and release.</p> <p>This Block may be pre-printed. Logo of the production approval holder, etc., is permitted if it can be contained within the Block.</p> |
| Block 5 | The purpose is to reference work order/contract/invoice or any other internal organisational process such that a fast traceability system can be established. The use of the Block for such traceability is mandatory in the absence of item Serial Numbers or batch numbers in Block 11. When not used, state N/A. |

Block 6 The Block is provided for the convenience of the organisation issuing the Certificate to permit easy cross-reference to the 'Remarks' Block 13 by the use of line item numbers. Block 6 must be completed where there is more than one line item.

Where a number of items are to be released on the Certificate, it is permissible to use a separate listing cross-referring Certificate and list to each other.

Block 7 The name or description of the item must be given. Preference must be given to use of the Illustrated Parts Catalogue (IPC) designation.

Block 8 State the Part Number. Preference must be given to use of the IPC number designation.

Block 9 Used to indicate the type-approved applications for which the released items are eligible for installation, based on information provided by the design approval holder. The following entries are permitted:

- a) At least one specific or series aircraft, propeller, or engine model as identified by the design approval holder. In case of engine or propeller release, state the aircraft approved applications, or, if application is not specific, state 'type-certificated engine/propeller'.
- b) 'None', to be used only when it is known that the items do not yet have a type-approved application, for example: pending type-certificate, for test only, pending approved data. If this category is used, then appropriate explanatory information must be provided in Block 13 and new items may only be released for Conformity purposes.
- c) 'Various' if known to be eligible for installation on multiple products, according to a procedure approved by the CAA.

In the case of multiple applications it is acceptable for this Block to contain cross reference to an attached document which lists such applications.

Any information in Block 9 does not constitute authority to fit the item to a particular aircraft, engine or propeller. The User/Installer must confirm via documents such as the Parts Catalogue, Service Bulletins, etc., that the item is eligible for the particular installation.

Any information in Block 9 does not necessarily mean that the product, parts or appliances are only eligible for installation on the listed model(s). Nor does it guarantee that the product, parts or appliances are eligible for installation on all entries in Block 9. Eligibility may be affected by modification or configuration changes.

Where a part is identified by the design holder in accordance with officially recognised Standards, then the part is considered a Standard Part and release with an Approved Certificate is not necessary. However where a production approval holder releases a standard part with an Approved Certificate then it must be able to demonstrate that it is in control of the manufacture of that part.

Block 10 State the quantity of items being released.

Block 11 State the Serial Number (or Batch Number) of the item if applicable. If not applicable, state 'N/A'.

Block 12 Enter one or a combination of appropriate standard words from the following table. The table lists, in quotes, the standard words permitted for use when releasing new items prior to entry into service, i.e. the items have not been previously used in operational service. It also details the circumstances and conditions under which they may be used. In all cases the certification rules relating to Block 14 apply, the appropriate box is to be marked, and Block 15 is to be signed.

TABLE OF STANDARD WORDS FOR NEW PARTS

1 'MANUFACTURED'

- a) The production of a new item in conformity with the applicable design data, or
- b) re-certification by the original manufacturer after rectification work on an item, previously released under paragraph 1(a), which has been found to be unserviceable prior to entry into service, e.g., defective, in need of inspection or test, or shelf life expired. Details of the original release and the rectification work are to be entered in Block 13, or re-certification of new items from conformity purpose to airworthiness purpose at the time of approval of the applicable design data, provided that the items conform to the approved design data. An explanation of the basis of release and details of the original release are to be entered in Block 13.

2 'INSPECTED'/'TESTED'

The examination of a previously released new item:

- a) to establish conformity with the applicable design data, or
- b) in accordance with a customer-specified standard or specification, details of which are to be entered in Block 13, or
- c) to establish serviceability and condition for safe operation prior to re-release as a spare, where the item has been obtained with an EASA Form 1 or Approved Certificate. An explanation of the basis of release and details of the original release are to be entered in Block 13.

3 'MODIFIED'

The alteration, by the original manufacturer, of a previously released item prior to entry into service. Details of the alteration and the original release are to be entered in Block 13.

The above statements must be supported by reference to the approved data/manual/specification. Such information shall be identified in either Block 12 or 13.

Block 13 It is necessary to state any information in this Block, either directly or by reference to supporting documentation, that identifies particular data or limitations relating to the item being released that are necessary for the User/Installer to make the final airworthiness determination of the item. The information must be clear, complete, and provided in a form and manner which is adequate for the purpose of making such a determination.

Each statement must be clearly identified as to which item it relates. If there is no statement, state 'None'.

Block 13
(cont)

Examples of conditions which would necessitate statements in Block 13 are:

- when the certificate is used for conformity purposes the following statement must be entered at the beginning of Block 13:
'ONLY FOR CONFORMITY, NOT ELIGIBLE FOR INSTALLATION ON IN-SERVICE TYPE-CERTIFICATED AIRCRAFT / ENGINE / PROPELLER';
- when the design data is not approved by the CAA, then the competent authority of the third country responsible for the approval of the design data must be identified and the following statement must be entered together with a reference identifying the approval:
'DESIGN DATA APPROVED BY <identify the responsible competent authority of a third country and the approval reference>';
- re-certification of new items from conformity purpose to airworthiness purpose at the time of approval of the applicable design data, provided that the items conform to the approved design data.

Provided that no change in design has occurred during the design data approval process, the manufacturer may state that the design data has been approved and that provided the specific component is still in the condition it was when it was shipped to the user/installer, the component is now eligible to be installed. The manufacturer must make this statement on a second Approved Certificate where in addition to any other necessary remarks, appropriate explanatory information must be provided. The following wording must be used: 'RE-CERTIFICATION OF NEW PARTS FROM CONFORMITY TO AIRWORTHINESS: THIS DOCUMENT ONLY CERTIFIES THE APPROVAL OF THE DESIGN DATA TO WHICH THIS ITEM WAS (THESE ITEMS WERE) MANUFACTURED, BUT DOES NOT COVER CONFORMITY/CONDITION AFTER RELEASE OF THE INITIAL APPROVED CERTIFICATE REF.....'

Approved Certificate (both for 'Conformity purposes' and for 'Airworthiness purposes') must be generated by the same organisation, i.e. the original manufacturer or prime manufacturer, whichever raised the original Approved Certificate for Conformity purposes.

- For complete engines and propellers the applicable type-certificate, or equivalent, must be referenced.
- For complete engines, a statement of compliance with the applicable emissions requirements current at the date of manufacture of the engine.
- Usage restriction for repaired items.
- Modification standard.
- Alternative approved items supplied.
- Concessions applicable.
- Non-compliance with certification specifications.
- Details of repair work carried out or reference to a document where this is stated.
- Compliance with, or non-compliance with Airworthiness Directives or Service Bulletins.
- Information on life limited items.
- Condition of items or reference to a document detailing this information.
- Manufacturing date or cure date.
- Shelf life data.
- Shortages
- Time Since New (TSN), Time Since Overhaul (TSO), etc.
- Re-certification of previously released 'new' items.

- Block 14 This Block may only be used to indicate the status of new items. The main purpose of the Certificate is to release items for airworthiness purposes, which means conformity with approved design data and in condition for safe operation.
- This airworthiness certification is valid in the UK.
- The certificate may also be used as a Conformity Certificate when items conform to applicable design data which are not approved for a reason which is stated in Block 13 (e.g., pending type-certificate, for test only, pending approved data).
- In this case the following additional statement must be entered at the beginning of Block 13 itself and not in a separate document: 'ONLY FOR CONFORMITY, NOT ELIGIBLE FOR INSTALLATION ON IN-SERVICE TYPE-CERTIFICATED AIRCRAFT/ENGINE/PROPELLER'.
- Mixtures of items released for Airworthiness and for Conformity purposes are not permitted in the same certificate. Also refer to the notes for completion of Block 9.
- Block 15 The hand-written normal signature of a person who has written authority from an approved production organisation to make Certifications in respect of new items. Use of a stamp instead of a signature is not permitted, but the authorised person may add a stamp impression to his or her signature to aid recognition. Subject to the agreement of the CAA in any particular case, computer-generated signatures are permitted if it can be demonstrated that an equivalent level of control, traceability and accountability exists.
- Block 16 State the full authorisation reference given by the CAA to the organisation releasing the new items.
- Block 17 The name of the person signing Block 15, printed, typed, or written in a legible form.
- Block 18 The date on which Block 15 is signed, in the format day/month/year. The month must be stated in letters (sufficient letters must be used so there can be no ambiguity as to the month intended).
- Block 19 Not used and strike out for release of new items.
- Block 20 Not used and strike out for release of new items.
- Block 21 Not used and strike out for release of new items.
- Block 22 Not used and strike out for release of new items.
- Block 23 Not used and strike out for release of new items.

INTENTIONALLY LEFT BLANK

Leaflet B-40 CAA Oversight of Military Registered Aircraft (COMRA) – Policy and Principles

Update: November 2022

The updated version of Leaflet B-40 has been published as a Supplementary Amendment (SA) to CAP 562.

It can be downloaded from this [list of CAP 562 \(CAAIP\) Supplementary Amendments](#)

Update: November 2022

The updated version of Leaflet B-40 has been published as a Supplementary Amendment (SA) to CAP 562.

It can be downloaded from this [list of CAP 562 \(CAAIP\) Supplementary Amendments](#)

Update: November 2022

The updated version of Leaflet B-40 has been published as a Supplementary Amendment (SA) to CAP 562.

It can be downloaded from this [list of CAP 562 \(CAAIP\) Supplementary Amendments](#)

Update: November 2022

The updated version of Leaflet B-40 has been published as a Supplementary Amendment (SA) to CAP 562.

It can be downloaded from this [list of CAP 562 \(CAAIP\) Supplementary Amendments](#)

Update: November 2022

The updated version of Leaflet B-40 has been published as a Supplementary Amendment (SA) to CAP 562.

It can be downloaded from this [list of CAP 562 \(CAAIP\) Supplementary Amendments](#)

Update: November 2022

The updated version of Leaflet B-40 has been published as a Supplementary Amendment (SA) to CAP 562.

It can be downloaded from this [list of CAP 562 \(CAAIP\) Supplementary Amendments](#)

Update: November 2022

The updated version of Leaflet B-40 has been published as a Supplementary Amendment (SA) to CAP 562.

It can be downloaded from this [list of CAP 562 \(CAAIP\) Supplementary Amendments](#)

Update: November 2022

The updated version of Leaflet B-40 has been published as a Supplementary Amendment (SA) to CAP 562.

It can be downloaded from this [list of CAP 562 \(CAAIP\) Supplementary Amendments](#)

Update: November 2022

The updated version of Leaflet B-40 has been published as a Supplementary Amendment (SA) to CAP 562.

It can be downloaded from this [list of CAP 562 \(CAAIP\) Supplementary Amendments](#)

Annex A Guidance Material to Support the Return of Military Registered Aircraft Operating Within the Policy Framework of Leaflet B-40 Back onto the Civil Register

Update: November 2022

The updated version of Leaflet B-40 has been published as a Supplementary Amendment (SA) to CAP 562.

It can be downloaded from this [list of CAP 562 \(CAAIP\) Supplementary Amendments](#)

Update: November 2022

The updated version of Leaflet B-40 has been published as a Supplementary Amendment (SA) to CAP 562.

It can be downloaded from this [list of CAP 562 \(CAAIP\) Supplementary Amendments](#)

Update: November 2022

The updated version of Leaflet B-40 has been published as a Supplementary Amendment (SA) to CAP 562.

It can be downloaded from this [list of CAP 562 \(CAAIP\) Supplementary Amendments](#)

Update: November 2022

The updated version of Leaflet B-40 has been published as a Supplementary Amendment (SA) to CAP 562.

It can be downloaded from this [list of CAP 562 \(CAAIP\) Supplementary Amendments](#)

Update: November 2022

The updated version of Leaflet B-40 has been published as a Supplementary Amendment (SA) to CAP 562.

It can be downloaded from this [list of CAP 562 \(CAAIP\) Supplementary Amendments](#)

Update: November 2022

The updated version of Leaflet B-40 has been published as a Supplementary Amendment (SA) to CAP 562.

It can be downloaded from this [list of CAP 562 \(CAAIP\) Supplementary Amendments](#)

Leaflet B-60 State Aircraft

1 Introduction

- 1.1 The European Aviation Safety Agency (EASA) regulations relating to airworthiness certificates have been in force since 28 September 2004. From this date the majority of aircraft holding a UK Certificate of Airworthiness (C of A) issued in accordance with the Air Navigation Order (ANO) became “EASA aircraft” and their certificates were deemed to be EASA Certificates of Airworthiness by the legislation. These aircraft have now been issued with EASA Certificates of Airworthiness (in accordance with Council Regulation (EC) No. 216/2008 (the Basic EASA Regulation) and Commission Regulation No. 1702/2003, Annex I, Part 21, Subpart H).
- 1.2 Article 1(2) of the Basic EASA Regulation as amended by Regulation (EC) No. 1108/2009 states: “This Regulation shall not apply to products, parts, appliances, personnel and organisations... while carrying out military, customs, police, search and rescue, fire-fighting, coastguard or similar activities or services.”
- 1.3 The Civil Aviation Authority (CAA) is not able to give an authoritative interpretation of EU/EASA legislation. However, the CAA's view of the meaning of this provision is set out below.

2 Interpretation

- 2.1 The CAA's interpretation of Article 1(2) of the Basic EASA Regulation, as amended by Regulation EC No. 1108/2009, is that a State aircraft is:
- a) any aircraft engaged in the service of the UK military; or
 - b) any aircraft engaged in the service of a Chief Officer of Police; or
 - c) any aircraft engaged in the service of HM Revenue and Customs; or
 - d) any aircraft (whether or not in the service of the UK Government) engaged to undertake search and rescue, fire-fighting, coastguard duties, fisheries patrol, border/immigration control, or to safeguard national security.
- 2.2 When applied to UK aircraft, the UK interpretation means that aircraft engaged in the following activities are not subject to the EASA Regulations and are regulated nationally: Police, Search and Rescue, Fire-Fighting, Fisheries Patrol, Revenue and Customs, Border/Immigration Patrol, Military activities or services (including training, target towing/simulation for the Military), plus any other activity necessary for National security. Other activities might also be included if they are considered to be “under the control or responsibility of a government or public authority”. If in doubt, advice should be sought from the CAA.
- 2.3 Government sponsored environmental monitoring is also considered an activity to be regulated nationally. Moreover, aircraft undertaking such activities are likely to be “specifically... modified for scientific purposes” and would therefore be subject to National airworthiness regulation under Annex II of the Basic EASA Regulation.
- 2.4 Conversely, this UK interpretation also means that aircraft engaged in the following activities, amongst others, are **not** excluded from regulation by EASA under Article 1(2) of the Basic EASA Regulation: Helicopter Emergency Medical Service (HEMS), calibration of aids to navigation/landing and recreational gliding or recreational parachuting even if the participants are military personnel.

3 National and EASA Certificates of Airworthiness

- 3.1 Consistent with EU legislation, EASA aircraft must be issued with EASA airworthiness certificates (under Part-21) and aircraft that are used for State purposes will normally have certificates issued under National legislation. Therefore, a change of use of a particular aircraft would require a change of certificate. However, Article 17 of the Air Navigation Order 2009 (as amended) provides for the use for State purposes of aircraft issued with an EASA airworthiness certificate by the CAA, provided the conditions of Article 17 are complied with. In summary, this means the aircraft must comply with the Basic Regulation and any Implementing Rules which would apply if it were an EASA aircraft, not fly outside the United Kingdom without the permission of the relevant competent authority and comply with any applicable United Kingdom National airworthiness requirements in CAP 747. The purpose of Article 17 is to allow an aircraft issued with an EASA airworthiness certificate to be used for State purposes e.g. to allow for the replacement of an aircraft requiring maintenance/repair.

NOTE: If the aircraft is to be modified to perform the State role, the modifications may be approved by EASA or the CAA. If the modifications are approved by the CAA, the aircraft must have a CAA Certificate of Airworthiness issued under National legislation.

- 3.2 Aircraft owners/operators are responsible for ensuring that their aircraft hold the appropriate airworthiness certificates, having regard to the nature of their operations. If any aircraft is used for State purposes, a UK National Certificate of Airworthiness must be obtained from the CAA except under the conditions of ANO Article 17(3).

4 The Right to International Flight

- 4.1 The Convention on International Civil Aviation (The Chicago Convention) deems "aircraft used in military, customs and police services" to be State aircraft. The Convention is applicable only to civil aircraft and is not applicable to State aircraft. Hence, the right to enter another country's airspace which is enshrined in the Convention is not applicable to aircraft undertaking military, customs and police services. Operators of these State aircraft are not entitled to cross National boundaries unless they have the prior permission of the country they wish to over fly and/or land in. Aircraft used in other than military, customs and police services are, for the purposes of the Chicago Convention, civil aircraft and hence may benefit from international overflight rights.

5 Continuing Airworthiness Oversight

- 5.1 Article 1, Paragraph 2 of the Basic EASA Regulation requires that:

"The Member States shall undertake to ensure that [State] activities or services have due regard as far as practicable to the objectives of this Regulation."

The CAA has amended the Air Navigation Order 2009 to introduce a revised set of requirements for the continuing airworthiness of non-EASA aircraft, reflecting the style of those regulations already used by EASA. These revisions replace existing requirements and provide a simplified set of requirements for the continuing airworthiness of non-EASA civil aircraft, i.e. non-military State aircraft and aircraft which come within Annex II of the EASA Regulation. The new requirements generally align with the current EASA system, avoid duplication where possible and so reduce regulatory burden and cost. A three year transition to the new requirements commenced in August 2012.

5.2 **State aircraft with an EASA Certificate of Airworthiness**

5.2.1 As explained in paragraph 3.1, if a State aircraft has an EASA Certificate of Airworthiness, it must comply with the continuing airworthiness requirements and procedures contained in the EASA implementing rules in the same way as if it were an EASA aircraft.

5.3 **State aircraft which conform with an EASA type certificate but have a National Certificate of Airworthiness**

5.3.1 If the State aircraft is an EASA aircraft type but has a National Certificate of Airworthiness the CAA policy is that these aircraft should be managed and maintained so far as possible in line with the EASA airworthiness regulations.

Hence, the following applies for a State aircraft with a National Certificate of Airworthiness:

- a) The aircraft must be of a type design approved by EASA or the CAA for the issue of a National Certificate of Airworthiness.
- b) The continuing airworthiness of the aircraft will be managed in accordance with Air Navigation Order 2009 (as amended) Part 3A.
- c) Maintenance of the aircraft is to be undertaken by an organisation approved for the type by the CAA.
- d) The aircraft is to be maintained in accordance with a maintenance schedule approved by the CAA.
- e) The aircraft is to be operated in accordance with a Flight Manual, the content of which has been approved under the type certificate, supplemental type certificate or CAA approved modification procedure. Any changes to the Flight Manual must be approved by the CAA, or alternatively approved by EASA and accepted by the CAA, in accordance with Part-21 or BCAR Section A or B, Chapter A2-5 or B2-2 paragraph 7 as appropriate.
- f) Changes (modifications and repairs) to the aircraft must be approved by the CAA, or alternatively approved by EASA and accepted by the CAA, in accordance with Part-21 or BCAR Section A or B, Chapter A2-5 or B2-2 paragraph 7 as appropriate.

NOTE: Modifications to install special-role equipment not possessing civil approval will need to be assessed and substantiated as being of no hazard to the aircraft. Operational performance of such modifications will not be evaluated other than to assess the effect on aircraft safety.

- g) All parts and appliances to be used on the aircraft, except special-role equipment with no civil approval, are to be maintained by an approved maintenance organisation. Special role equipment shall be maintained in accordance with the manufacturer's recommendations.
- h) The aircraft must remain in compliance with Airworthiness Directives, mandatory modifications, inspections and changes to approved documentation applicable to the type as specified in CAP 747 (as amended).

6 Check Flight Requirements

6.1 State Aircraft which conform with an EASA Type Certificate

6.1.1 Periodic testing for the purpose of continuing airworthiness monitoring is not mandated for aircraft already possessing an EASA Certificate of Airworthiness (frequently referred to as EASA aircraft). EASA aircraft types that are operating for State purposes will normally be issued with a National Certificate of Airworthiness. With regard to Continuing Airworthiness Check Flights, these UK National State aircraft will be treated in the same way as EASA aircraft.

6.1.2 Consequently, an EASA aircraft type, whether new or being modified for UK National State purposes, will not require a routine check flight prior to the issue of a National Certificate of Airworthiness. There are exceptions to this as follows. Where an aircraft has been in storage, or out of service, for a prolonged period of time, a 'new' aircraft is disassembled for shipping to the UK, on arrival in the UK following reassembly, a check flight will be required. In addition, where the aircraft has been modified, e.g. to install special-role equipment, since original manufacture, a check flight may be required to approve the modification or assess it as being of no hazard to the aircraft. If there is no C of A in force, "A" or "B" conditions may be used to accomplish this task, as applicable.

6.1.3 In the case of a used aircraft that is an EASA aircraft type imported for UK National State purposes from a non-EU member state, that does not have a membership agreement with EASA, it is necessary to determine that the individual aircraft conforms to its type certification standard and is airworthy. As stated above, the CAA policy is that these State aircraft should be managed as far as possible in line with the EASA airworthiness regulations. The CAA is no longer routinely involved in check flights of used EASA aircraft being imported from non-EU countries. EASA Part M, M.A.904 and AMC refers to the airworthiness review that is required to be carried out and includes a check flight report as part of the documentation needed to support the airworthiness review. The responsibility for satisfying M.A.904 rests with the Continuing Airworthiness Maintenance Organisation (CAMO). Consequently, for an EASA aircraft type imported for UK National State purposes from a non-EU member state, the CAMO (approved in accordance with either EASA Part M Subpart G or BCAR Section A, Chapter A8-25 depending on whether an EASA or National C of A is first required) will need to arrange for the check flight to be carried out. The completed Check Flight Schedule should be provided to the CAA Surveyor at the time of the aircraft survey for the issue of the C of A.

6.2 State Aircraft which do not conform with an EASA Type Certificate

6.2.1 British Civil Airworthiness Requirements (BCARs) continue to be applicable to non-EASA aircraft types, including any that might be used for State purposes. For a National C of A to be issued to a non-EASA aircraft it is necessary for the CAA to determine that the individual aircraft conforms to its type certification standard and is airworthy. To establish this, a check flight is required to be completed satisfactorily prior to the issue of the C of A and the National Airworthiness Review Certificate (National ARC), see BCAR Section A, Chapters A3-1 and A3-3. Where the aircraft already has a C of A, it is no longer mandatory to conduct a check flight to support the renewal of a National ARC. The decision on when a check flight is required, as part of the continuing airworthiness oversight of the aircraft, falls upon the aircraft pilot-owner, maintainer or continuing airworthiness management organisation (as applicable) in accordance with BCAR Section A, Chapter A6-1, paragraph 4. The AMC to Chapter A6-1 paragraph 4 provides guidance material to assist in the determination of when a check flight is necessary.

Leaflet B-70 Aircraft Insurance

- 1** Attention is drawn to the fact that when the CAA Safety Regulation Group's Test Pilots fly aircraft for any test purposes, neither the CAA nor the Test Pilots accept responsibility for any damage to the aircraft, or to third parties, or to any person or property whatsoever.
- 2** All owners are, therefore, required to ensure that insurance policies covering damage to their aircraft and to third parties are suitably endorsed to cover flights by the CAA Safety Regulation Group's Test Pilots.

NOTE: It is understood that in general, Insurers and Underwriters are willing to extend the cover of their aircraft policies for this purpose on request and without further charge.

INTENTIONALLY LEFT BLANK

Leaflet B-80 Civil Aviation Regulation of Light Aircraft used for General Aviation

1 Introduction

- 1.1 It is the intention of the Airworthiness Evaluation and Surveillance Department of the CAA to use this Leaflet to highlight changes brought about by the implementation of European Regulations which have continued airworthiness implications for UK operators of Light Aircraft used for General Aviation (GA) purposes.
- 1.2 The above regulations will increasingly impact UK operators of Light Aircraft used for General Aviation where issued with EASA Airworthiness Certificates by the CAA from 28 September 2004.

2 References

Air Navigation Order and the Regulations (CAP 393)

GR No. 24 - Light Aircraft Piston Engine Overhaul Periods (CAP 747)

British Civil Airworthiness Requirements Sections A and B (CAP 553/554)

Regulation (EC) 216/2008 – Common rules in the field of civil aviation and establishing EASA. (“the basic EASA Regulation”)

Commission Regulation (EC) 1702/2003 – Implementing rules for airworthiness and environmental certification of aircraft and related products (“the Certification Regulation”)

The Annex to the Certification Regulation (Part 21)

Commission Regulation (EC) 2042/2003 – Continuing airworthiness of aircraft and aeronautical products (“the Continuing Airworthiness Regulation”)

Annex I to the Continuing Airworthiness Regulation (Part M)

Light Aircraft Maintenance Programme (LAMP) (CAP 766 and 767)

Mandatory Requirements for Airworthiness (CAP 747)

Parachuting (CAP 660)

3 Definitions

- 3.1 Light Aircraft means those aircraft with a maximum take off mass of 5700 kg or less excluding multi-engined helicopters.
- 3.2 EASA means the European Aviation Safety Agency.
- 3.3 Non EASA aircraft means:
Aircraft coming within Annex II of the Basic EASA Regulation and Aircraft engaged in military, customs or police services. Aircraft classified by the CAA as Annex II are listed in publication CAP 747 (Section 1 Part 2 refers).
- 3.4 EASA Airworthiness Certificate means a Certificate issued or deemed to be issued under the Certification Regulation recognising that an aircraft complies with the applicable airworthiness requirements. These certificates are classified as Certificates of Airworthiness (Form 25), Restricted Certificates of Airworthiness (Form 24), or Permits to Fly (Form 20).

- 3.5 EASA Certificate of Airworthiness means a Certificate recognising that an aircraft conforms to a type certificate, issued or deemed to be issued in accordance with Part-21.
- 3.6 EASA Restricted Certificate of Airworthiness means a Certificate recognising that an aircraft conforms to a restricted type certificate which has been issued in accordance with Part-21 or which has been shown to comply with specific certification specifications ensuring adequate safety.
- 3.7 EASA Permit to Fly, issued to an EASA aircraft, which has not been shown to meet, or currently does not satisfy the applicable airworthiness requirements for the issue of a Certificate of Airworthiness or Restricted Certificate of Airworthiness but which is capable of safe flight under defined conditions.
- 3.8 Commercial Air Transport (CAT) means the carriage of Passengers / Cargo / Mail for remuneration.
- 3.9 General Aviation (GA) as defined in this Leaflet means Light Aircraft not used for Commercial Air Transport or Public Transport.
- 3.10 Public Transport for the purposes of this Leaflet is defined as where valuable consideration is given by a person for the purposes of hiring an aircraft, conferring on a particular person the right to fly the aircraft. e.g. from a flying club or from an owner/operator.

NOTE 1: Under such circumstances the flight is deemed to be public transport for continuing airworthiness purposes. The flight will be private for all other purposes (provided no other payments are made in relation to the flight).

Aerial Work for the purposes of this Leaflet is defined as where valuable consideration is given in respect of the flight. e.g. flying instruction.

NOTE 2: If the only payment made is for the payment of the pilot (flying instructor), the flight is deemed to be private for airworthiness purposes. This enables private owners to pay a flying instructor for lessons in their own aircraft.

4 General

- 4.1 Commission Regulation (EC) 1702/2003, including its associated Annex (Part-21), together with Commission Regulation (EC) 2042/2003 Annex 1 (Part-M), has direct implications on continuing airworthiness for operators of UK registered aircraft.
- 4.2 These EC regulations are common to all EU member states and compliance is obligatory. However, there are transitional provisions regarding entry into force of Part-M, depending on aircraft use.
- 4.3 Part-21 sets out airworthiness certification rules for aircraft, related products, parts, and appliances together with those for design and production organisations. Subpart H of Part-21 deals with EASA Airworthiness Certificates.
- 4.4 Part-M sets out continuing airworthiness (CAW) and validation rules for those aircraft issued with an EASA Certificate of Airworthiness or a Restricted Certificate of Airworthiness. It also includes rules for those who maintain aircraft not used for CAT operations.
- 4.5 National legislation as prescribed in the Air Navigation Order and implemented by reference to BCAR's Sub-Sections A/B-3 continues to apply for aircraft classified by the CAA as non-EASA aircraft, which will retain a national Airworthiness Certificate.

5 Part-21 Subpart H – Airworthiness Certificates

- 5.1 As a result of transitional provisions in the Continuing Airworthiness Regulation much of Part-M does not yet apply to aircraft issued with an EASA Airworthiness Certificate which are not involved in CAT. This means that until notified otherwise, renewal of EASA Airworthiness Certificates issued by the UKCAA for such aircraft will be through the existing national standards prescribed in BCAR's Sections A/B.
- 5.2 Owners and operators are reminded that EASA Certificates of Airworthiness and Restricted Certificates of Airworthiness are not categorised based on operational usage. It should be further noted that the operational use of aircraft is not yet regulated by Commission Regulations. This means that until notified otherwise, the carriage of particular equipment for all UK registered aircraft specific to the circumstances of the flight is mandated through the Air Navigation Order 2009 (as amended) Articles 37, 38 and 39 and Schedules 4 and 5.
- 5.3 To enable Approved Maintenance Organisations and Licensed Engineers to determine the required maintenance to be performed on an aircraft, it is the responsibility of the Owner/Operator to declare the purpose for which the aircraft is currently operated.
- 5.4 Where an aircraft being subject to a maintenance inspection can only satisfy the requirements for Private purposes, the Approved Maintenance Organisation or Licensed Engineer, when certifying a scheduled maintenance inspection, should specify, "**Maintained for Private purposes only**" in the aircraft log book.
- 5.5 Aircraft operated for Private purposes may continue to apply the pilot maintenance provisions of LAMS and Regulation 12 of the Air Navigation (General) Regulations 2006. Furthermore, for aircraft below 2730 kg Maximum Take-off Weight, which are operated for Private purposes, the installed piston engine may continue in service indefinitely subject to compliance with CAP 747 GR No. 24. However, whenever the aircraft is to be used for Public Transport, Aerial Work or CAT purposes, further conditions apply as follows:
- 5.5.1 Any pilot maintenance, which has been performed, as provided for by ANO General Regulation (2006) number 12, will need to be assessed and re-certified as necessary prior to the aircraft being operated for the purposes of CAT, Public Transport or Aerial Work.
- NOTE:** Pilot maintenance is prohibited for aircraft operated in the parachuting role.
- 5.5.2 Any permitted pilot scheduled maintenance, which has been performed as provided for by LAMS Section 5, will need to be assessed and re-certificated as necessary prior to the aircraft being operated for the purposes of CAT, Public Transport or Aerial Work.
- 5.5.3 Any piston engine overhaul lives, as published in CAP 747 GR No. 24, must be those applicable to aircraft usage. As such, where an aircraft usage changes to CAT, Public Transport or Aerial Work extensions in excess of 20% above the normal overhaul period are not permitted, and to qualify extensions of up to 20% maintenance inspections in accordance with CAP 747 GR No. 24 are required.
- 5.5.4 An assessment of applicable Air Navigation Order and Official Record Series 4 requirements must be carried out and compliance verified.

Certification of maintenance associated with the above is to be completed by an appropriately licensed engineer or an organisation specifically approved for the purpose.

Owners and Operators who purchase or lease an aircraft intended to be operated for the purposes of CAT, Public Transport or Aerial Work use must review the aircraft maintenance records to ensure that the current maintenance status is compatible with its intended use.

6 Part-M – Continuing Airworthiness Requirements

6.1 Part M Implementation for Non-large Aircraft Owners/Operators

EASA Part M regulation is due to come into full effect on 28 September 2008. EASA has proposed a revision, which would allow Member States the ability to opt-out of compliance with Part M, for a further year (for aircraft not used in Commercial Air Transport) and the ability to continue to use, nationally licensed maintenance personnel, for a further two years. The UK CAA's view is that, to opt-out would only penalise those organisations who sought to fully comply, by the due date of 28 September 2008 and create further confusion. The CAA has therefore decided, we will **not** make use of the option to delay implementation. In the UK, we will therefore opt to comply by 28 September 2008, consistent with existing regulation and as previously indicated.

6.2 Maintenance Approval

From 28 September 2008 Part M Subpart F or Part 145 applies. Organisations who perform aircraft maintenance under a national approval (i.e. BCAR A8-15) will be able to continue to do so, within the extent of their current approval, from 28 September to 5 January 2009. These organisations will be limited to performing 'non-complex' tasks until they obtain a Part M Subpart F or Part 145 approval.

6.3 Certificate of Release to Service

From 28 September 2008 all aircraft Certificates of Release to Service (CRS) will be issued by appropriately rated Part 66 licensed personnel, in accordance with Part M, M.A.801 (b) 2. Where there is a need to accomplish a "*complex task*", as defined in Part M Appendix VII, an organisation holding the appropriate EASA approval should be contracted. In cases where this is not feasible, the CAA will consider if the use of an Exemption to allow a BCAR Section L, B or D licence holder, to oversee and certify the task is appropriate.

6.4 Aircraft Maintenance Programme

From 28 September 2008 Part M applies. For aircraft where it is intended to utilise the CAA Light Aircraft Maintenance Programme (LAMP), final transition must be completed by this date. For aircraft not utilising the LAMP, the Aircraft Maintenance Programme will need to be approved, in accordance with Part M, M.A.302 and M.B.301, by this date.

6.5 Certificates of Airworthiness and Airworthiness Review Certificates (ARC)

UK registered, EASA General Aviation aircraft, now have an EASA non-expiring Certificate of Airworthiness. For those aircraft who's Airworthiness Review Certificate (ARC) expires in the period, 28 September 2008 to 5 January 2009, an organisation holding Part M Subpart G approval with ARC privilege, or an organisation nationally approved to recommend the issue or renewal of a Certificate of Airworthiness for the type, may be used to renew the ARC. An Exemption to the EU regulation will be raised, to allow nationally approved organisations to make these recommendations during this period. For further guidance on the issue and extension of Airworthiness Certificates, refer to, www.caa.co.uk.

6.6 **Commercial Air Transport**

All aircraft used for Commercial Air Transport will be subject to the full requirements of EASA Part M as of 28th September 2008.

INTENTIONALLY LEFT BLANK

Leaflet B-90 Information for Continued Airworthiness of Non-EASA Aircraft Designed in the UK and Elsewhere

1 Introduction

- 1.1 The attention of operators of non-EASA aircraft designed in the United Kingdom and elsewhere is drawn to this Leaflet which concerns the scope of continued airworthiness information to be expected from the UK in respect of aeroplanes and rotorcraft. At the present time balloons, airships and gliders are not covered.
- 1.2 The purpose of this Leaflet is to provide information only. Nothing in it should be taken as overruling any written statement which may be given at any time by the CAA in respect of any given aircraft.

2 Obligations of Type Design Organisations, Type Responsibility Agreement Holders and the CAA

- 2.1 The attention of United Kingdom Type Design Organisations is drawn to their obligations under BCAR Chapter A5-1 in respect of the provision and publication of information relating to the Continued Airworthiness of aeroplanes.
- 2.2 BCAR Chapter A5-1 requires the Type Design Organisation to promulgate such information and ICAO Annex 8, Part II places responsibility on the CAA to transmit such information to other Contracting States which have advised that they have aircraft of the specific Type on their Registers.
- 2.3 Where a UK Type Design Organisation no longer exists or fails to discharge its responsibilities to provide the minimum provisions in respect of continuing airworthiness to enable ICAO Annex 8 to be satisfied, the CAA will review all options to maintain the ICAO Annex 8 certification status for the type. These will include:
 - a) finding another suitably approved organisation to take over the type design responsibility, or
 - b) where the aircraft is a simple type, finding a suitably capable organisation who will enter into a Type Responsibility Agreement with the CAA (see 2.4 below).The CAA may temporarily take responsibility directly until a conclusion is reached (see 2.5 below).
- 2.4 The holders of a Type Responsibility Agreement in accordance with BCAR A5-1, paragraph 4, although not meeting the criteria of a Type Design Organisation, are deemed to be capable of monitoring the continued airworthiness of the type to enable CAA to maintain its ICAO Annex 8 responsibilities.
- 2.5 Where a Type Design Organisation or a Type Responsibility Agreement holder ceases to operate, the CAA may maintain the type certification status in accordance with ICAO Document 9760 Airworthiness Manual Part III, Chapter 4, by:
 - a) taking the ICAO Annex 8 responsibility itself, and/or
 - b) placing a limit on the validity of the type certificate (or equivalent) until such time as service experience reveals an unsafe condition with no organisation able to submit proposals for modification.

The CAA will only provide such support for a limited period. If a new Type Design Organisation or Type Responsibility Agreement cannot be established within a reasonable period, it should be expected that the Type Certificate will be withdrawn and the Certificate of Airworthiness cancelled.

3 UK Aircraft Types Having Continued Airworthiness Support

- 3.1 The Aircraft Types listed in the Appendices to this Leaflet are supported with information for Continued Airworthiness in accordance with:
- a) paragraph 2.2 above for Type Design Organisations (Appendix 1).
 - b) paragraph 2.4 above for Type Responsibility Agreements (Appendix 2).
 - c) paragraph 2.5 above when CAA holds the responsibility (Appendix 3).

4 UK Aircraft Types Not Having Support for Continued Airworthiness

- 4.1 Owners and Operators of UK registered aircraft of UK design are advised that those aircraft not listed in the Appendices may no longer be eligible for Certificates of Airworthiness.
- 4.2 Owners and operators of aircraft registered in other countries should consult their national authorities concerning their eligibility for maintaining their National Certificate of Airworthiness.
- 4.3 Article 18 of the Air Navigation Order 2009 (as amended) and BCAR A5-1 paragraph 1.2 are applicable whether or not an Aircraft Type of UK manufacture is the subject of a UK Type Certificate.

5 Withdrawal of Airworthiness Support for an Aircraft Type of UK Design

Where this occurs, the UK Type Design Organisation must notify their withdrawal of support for the Continued Airworthiness from an Aircraft Type, by the issue of an Alert Service Bulletin or similar document having CAA approval. The CAA will then advise other Airworthiness Authorities accordingly.

6 Foreign Aircraft Types Having Continued Airworthiness Support from a UK Organisation

Once an aircraft type of non-UK design has been declared as an orphan by the Airworthiness Authority of the State of Design, the individual aircraft of that type on the UK register do not meet the criteria to hold Certificates of Airworthiness. An 'orphan' type is one which is no longer supported by a Type Design Organisation or by the Airworthiness Authority of the State of Design. Should one or more of the owners of such aircraft wish to retain the ability to hold a Certificate of Airworthiness they may be able to conclude a Type Responsibility Agreement with the CAA. Without such an arrangement the aircraft will no longer have the ability to maintain a Certificate of Airworthiness and will need to transfer to a Permit to Fly. See Appendix 4 of this Leaflet for foreign aircraft types with current Type Responsibility Agreements.

Appendix 1 Non-EASA Aircraft Types of UK Design having Continued Airworthiness Support provided by a Type Design Organisation

Aircraft Types which are recognised as having continued airworthiness support either from their original Type Design Organisation or from another Type Design Organisation.

Type	Responsible Organisation
Aviation Traders ATL 98 Carvair	Aviation Traders Ltd. Building 105 Bournemouth International Airport Christchurch Dorset BH23 6NW Tel: 01202 581900
Scottish Aviation Twin Pioneer	Tenencia Ltd. Dakota House Coventry Airport Coventry Warwickshire CV8 3AZ Tel: 024 7688 2695
Westland Bell 47G-4A & -3B-1	GKN Westland Helicopters Ltd. Lysander Road Yeovil Somerset BA20 2YB Tel: 01935 704330

INTENTIONALLY LEFT BLANK

Appendix 2 Non-EASA Aircraft Types of UK Design having Continued Airworthiness Monitoring provided by a Type Responsibility Agreement Holder

Aircraft types where the continued airworthiness is maintained under a Type Responsibility Agreement with a suitably qualified organisation.

Type	Responsible Organisation
DH 60 Series DH 80A Puss Moth DH 83 Fox Moth Series DH 85 Leopard Moth DH 87B Hornet Moth DH 94 Moth Minor Miles M2 Hawk Miles M3 Falcon Miles M5 Sparrowhawk Miles M11 Whitney Straight Miles M14 Hawk Trainer Miles M17 Monarch Miles M38 Messenger Miles M65 Gemini Thruxton Jackaroo (modified DH 82A)	Air Stratus Ltd. Oaksey Park Airfield Oaksey Malmesbury Wiltshire SN16 9SD Tel: 01666 575111
Percival P10 Vega Gull Percival P40 Prentice Percival Proctor 3, 4 and 5	Tenencia Ltd. Dakota House Coventry Airport Coventry Warwickshire CV8 3AZ Tel: 024 7688 2695
DH 82 Tiger Moth Series DH 89A Dragon Rapide Series DHC-1 Chipmunk (English and Portuguese built variants only) Scottish Aviation Bulldog Series	De Havilland Support Ltd. (DHSL) Building 213 Duxford Airfield Duxford Cambridgeshire CB22 4QR Tel: 01223 830090
Austers (All variants except Agricola) Beagle Auster D5 series 180 Husky Beagle A61 Terrier Beagle A109 Airedale	Cooper Aerial Surveys Engineering Ltd Wickenby Airfield Langworth Lincoln LN3 5AX Tel: 01673 885970

INTENTIONALLY LEFT BLANK

Appendix 3 Non-EASA Aircraft Types of UK Design having Continued Airworthiness Monitoring provided by the CAA

Aircraft types where the CAA is taking direct responsibility for continuing airworthiness in order to maintain the type certificated status, until such time as either a suitable responsible organisation is found or service experience reveals an unresolvable unsafe condition.

NOTE: Aircraft types no longer listed may not qualify for the issue of a C of A.

Type	Responsible Organisation
Beagle 206	Civil Aviation Authority Safety Regulation Group Airworthiness Evaluation and Surveillance Aviation House Gatwick Airport South West Sussex RH6 0YR Tel: 01293 567171

INTENTIONALLY LEFT BLANK

Appendix 4 British-Registered Non-EASA Aircraft Types of Foreign Design having Continued Airworthiness Monitoring provided by a UK Type Responsibility Agreement Holder

Type	Responsible Organisation
Stampe SV4 Series	Tiger Airways Hangar SE47 Gloucestershire Airport Staverton Cheltenham Gloucestershire GL51 6SS Tel: 01452 714767
Jodel D150	Prop-Air Corporation Ltd Merrie Oak Chartway Street Sutton Valence Maidstone Kent ME17 3JA

INTENTIONALLY LEFT BLANK

Leaflet B-100 Acceptance Standards for Imported Aircraft for which a UK National Certificate of Airworthiness is Sought

1 Introduction

This Leaflet has been revised to advise of the implementation of changes that have been made to the requirements for BCAR A8-8, Group E3 Approvals.

2 Requirements

- 2.1 BCAR Sections A and B, Sub-sections A3-2 and B3-2, specify the requirements for the issue of Certificates of Airworthiness. These sub-sections have been revised for aircraft with a maximum take off weight above 15 000 kg to require a report to be submitted by an appropriate design organisation, certifying that the airworthiness standard of the aircraft conforms to, or differs in a defined manner from, a standard approved by the CAA for the issue of a Certificate of Airworthiness for that type. For the purposes of this Leaflet, an appropriate design organisation is an organisation approved in accordance with BCAR A8-8 Group E3 or it may be the Type Certificate holder if considered acceptable.

NOTE: In the case where the issue of a Certificate of Airworthiness is to be completed outside the United Kingdom at a place where an Organisation is not specifically approved to provide reports for the purpose, the overseas Organisation shall be one that is acceptable to the CAA.

- 2.2 For other aircraft with a maximum take off weight below 15 000 kg, a suitably approved maintenance organisation, or, subject to CAA agreement, appropriately licensed aircraft maintenance engineers for aircraft types not listed in paragraph 17 of CAP 562 Leaflet H-30 may be used. However, the use of the services of an E3 approved organisation is recommended, particularly where the work to establish compliance is significant.

- 2.3 BCAR Section A, Sub-section A8 details the various organisation approvals. The requirements for design organisation approvals under Sub-section A8-8 have been amended to enable an E3 Design Organisation to provide reports and to certify that a particular aircraft conforms to, or differs in a defined manner from, a standard approved by the CAA for the issue of a Certificate of Airworthiness for that aircraft type. Previously the E3 approval was limited to the provision of reports and certification of compliance with design standards only. The amendment addresses all of the airworthiness standards associated with issue of a Certificate of Airworthiness and applicable operational requirements. Consequently an E3 Design Organisation will now be required to have suitable procedures and arrangements for the inspection of aircraft to establish compliance with the documented airworthiness standard.

- 2.4 The BCAR Chapter A8-8 requirement contains an appendix that gives guidance on the format and content of the report to be provided by the E3 Design Organisation.

NOTE: Organisations should note that for EASA Aircraft Types, the introduction of the non-expiring C of A in accordance with Part 21 Sub-part H and Part M Sub-part I was introduced on 28 September 2007. Following this date, the requirement for an E-3 approval and associated report ceased for EASA aircraft. Following 28 September 2007, organisations bringing EASA aircraft onto the register of an EASA member state, including the UK, are required to provide an Airworthiness Review in

accordance with Part M, M.A.710. This review may in reality be presented in a similar format to an existing E-3 Report, but it must comply with the categories and requirements laid down under M.A.710.

Leaflet B-110 The Acceptance of Aircraft Components

1 Purpose

The purpose of this Leaflet is to provide guidance on the acceptance of aircraft components, so that responsibilities under the applicable Commission Regulations, the Air Navigation Order (ANO) and BCAR Section A, Chapter A8 may be satisfied in a manner acceptable to the CAA. This Leaflet provides guidance to persons issuing the Certificate of Release to Service for the installation of components, or for organisations sourcing such components for incorporation into parts or assemblies for release under a Production Organisation Approval.

2 Applicability

- 2.1 This Leaflet is applicable to aircraft which remain subject to national legislation as defined in Articles 1(2) and 4(4) of Regulation (EC) No. 216/2008 (i.e. non-EASA aircraft as specified in Annex II or aircraft engaged in military, customs, police or similar services). This Leaflet applies to components intended for installation in aircraft, or for incorporation into assemblies produced under a UK national Production Organisation Approval in accordance with BCAR Section A, Chapter A8.
- 2.2 Aircraft not defined as above are subject to Regulation (EC) No. 1702/2003, incorporating Part 21, and Regulation (EC) No. 2042/2003, incorporating Part-145. Aircraft that are subject to Article 1(1) of Regulation (EC) No. 216/2008 shall comply with Regulation (EC) No. 1702/2003, incorporating Part 21 and Regulation (EC) No. 2042/2003, incorporating Part 145 and Part M, as applicable. The European Aviation Safety Agency is therefore responsible for guidance regarding these aircraft (EASA aircraft). The information in this Leaflet is, however, relevant to these aircraft and is intended as guidance for the UK aviation industry supplementing the information available from EASA (www.easa.europa.eu).
- 2.3 A component received in accordance with this Leaflet should also have its eligibility for an individual aircraft established by the end user, considering applicable UK Mandatory Requirements for Airworthiness (CAP 747) and other relevant Aircraft Technical Publications.

3 Definitions

- 3.1 For the purpose of this Leaflet the following definitions apply:
- a) **Aircraft Component** means any engine, propeller, part or appliance.
 - b) **Parts and Appliances** shall mean any instrument, equipment, mechanism, part, apparatus, appurtenance or accessory, including communications equipment, that is used or intended to be used in operating or controlling an aircraft in flight and is installed in or attached to the aircraft. It shall include parts of an airframe, engine, or propeller.
 - c) **Product** shall mean an aircraft, engine or propeller.
 - d) **Standard Parts**. A part is considered as a standard part where it is designated as such by the design approval holder (DAH) responsible for the product, part or appliance in which the part is intended to be used.

In order to be considered a standard part, all design, manufacturing, inspection data and marking requirements necessary to demonstrate conformance of that part must be in the public domain and published as part of a national or international specification.

NOTE: Parts which are the subject of specific product or equipment approvals such as National Equipment Approvals, grandfathered in accordance with the provisions of paragraph 13 of Article 2 of Regulation (EC) No. 1702/2003, Technical Standard Orders (TSO), Joint Technical Standard Orders (JTSO) or European Technical Standard Orders (ETSO) are not considered as standard parts.

When designating a standard part, the DAH should ensure that the effect on the design of any manufacturing tolerances within the specification are fully taken into account in the intended application. If it is found necessary to apply additional qualification or selection criteria over and above the published specification in order to satisfy the intended design requirements (such as enhanced levels of inspection, burn-in, or environmental tests etc.) then the DAH should allocate its own part number reference and such parts cannot be considered as standard parts.

- e) **Critical Part** means a part for which the failure analysis shows that hazardous effects, or worse, are not to occur at a rate in excess of extremely remote. This can also include parts for which a replacement time, inspection interval, or related procedure is specified in the Airworthiness Limitations section of the manufacturer's maintenance manual or Instructions for Continued Airworthiness.
- f) **Non-required Equipment** means equipment not required for type certification or by the operating rules or whose improper functioning would not reduce safety.
- g) **Permanent** means an item of equipment not defined as a Portable Electronic Device (PED) and that is not designed to be installed or removed by flight crew, and would typically require maintenance action for installation or removal.
- h) **Specification** A specification would typically consist of a drawing and/or DDP (Declaration of Design and Performance). The DDP would identify any limitations for the equipment installation. The source control drawing would show the part, labelling and the supplier.

4 Authorised Release Document

This document is required for any aircraft component which is to be installed in an aircraft, except that it is not required for standard parts as defined in paragraph 3.1 d).

- 4.1 When received from a manufacturing source approved to Part-21, the Authorised Release Document will be an EASA Form 1 issued under the terms of that Approval. Prior to 28 September 2004 the Authorised Release Document used by an organisation holding an appropriate JAR-21 Subpart G approval was a JAA Form 1, after 28 September 2004 these organisations should have transitioned to Part 21 and now be using the EASA Form 1.
- 4.2 Prior to 28th September 2005 the Authorised Release Document used by an organisation holding an appropriate CAA BCAR A8-1 or A8-2 Approval or approved to national rules by an EU member state or Norway, Iceland or Switzerland, would have been a JAA Form 1 issued under the terms of that Approval with the following statement in Block 13: "This certificate has been issued under(reference to the issuing NAA national rules applicable)".
- 4.3 Products, parts or appliances, for aircraft which remain subject to UK national legislation as defined in Articles 1(2) and 4(4) of Regulation (EC) No. 216/2008 (non-EASA aircraft), may be released by an appropriately approved organisation on a UK

CAA Approved Certificate. CAAIP Leaflet B-30 gives further guidance regarding the use of a UK CAA Approved Certificate.

- 4.4 When received from a manufacturing source appropriately approved by the Federal Aviation Administration (FAA), which arranges for the release of the aircraft component, the Authorised Release Document will be FAA Form 8130-3, Authorised Release Certificate/Airworthiness Approval Tag for aircraft engines, propellers and all other new components including APUs.

Further information regarding the use of FAA Form 8130-3 is contained in FAA Order 8130.21. As a result of the Common Release Certificate project between the JAA, FAA and Transport Canada, it has been accepted that inclusion of the word "Export" is not necessary on each authority's respective forms. Inclusion of the word "Export" in Block 13 of a Form 8130-3 remains as an option to meet any existing bilateral agreement commitments.

Where a Form 8130-3 has been raised under previous revisions of the FAA Order then an export statement is still required. The current issue of the Form may be recognised by its revision - Form 8130-3 (6-01).

Form 8130-3 certifying conformity to the Export requirements of a specific country other than within the EU is not acceptable. Receiving organisations should ensure that where there are export requirements specific to the UK, these have been satisfied.

- 4.5 The CAA position regarding FAA-PMA parts is set out in EASA Decision No.2007/003/C which can be found at:

http://www.easa.europa.eu/ws_prod/g/rg_agency_desc_main.php.

- 4.6 The acceptance of components from outside the EU is dependent upon formal arrangements being in place between EASA and the Airworthiness Authority of the exporting country. In addition to the information in this Leaflet further detail of such arrangements may be found on the EASA website (<http://www.easa.europa.eu/home/index.html>) under the 'International Cooperation – Working Arrangements' section.

For aircraft which remain subject to national legislation, as defined Articles 1(2) and 4(4) of Regulation (EC) No. 216/2008, contact chiefsurveyoroffice@caa.co.uk for further information regarding components not covered by the paragraphs above.

- 4.7 **The Need for Authorised Release Documents for Commercial Off the Shelf Equipment**

- 4.7.1 UK ANO Article 38(5) requires that all equipment installed or carried on an aircraft is installed/stowed, maintained and adjusted such that it is not a source of danger in itself or will impair the airworthiness of the aircraft or any other equipment or service necessary for the safety of the aircraft.

- 4.7.2 Part 21A.307 requires that no part or appliance (except a standard part), shall be eligible for installation in a type-certificated product unless it is accompanied by an authorised release certificate (EASA Form 1).

GM21A.133(a) identifies that manufacturers or providers of parts identified in the product support documentation as 'industry supply' or 'no hazard', will not be considered eligible for production organisation approval, therefore authorised release documents are not available for such parts. As the manufacturer is unable to release equipment on an EASA Form 1, an alternative means of release must be sought.

The following identifies UK CAA policy to be applied by those organisations for which the CAA are responsible, whether they are approved under National Rules (BCAR A8 and the ANO) or Part 21.

The European Aviation Safety Agency is aware of this guidance material and it may be subject to change in light of revisions to the requirements and/or guidance material.

NOTE: For non-EASA aircraft as defined by Annex II of Regulation (EC) No. 216/2008 the principles of the following should also be applied.

4.7.3 **Permanently Installed Equipment**

4.7.3.1 Article 3(d) of Regulation (EC) No. 216/2008 defines those parts and appliances (i.e. items of equipment) that are subject to Part 21 design and production and Part 145 maintenance requirements. It includes those items intended to be used in operating or controlling the aircraft. For the purposes of the release of commercial off-the-shelf (COTS) 'industry supply' equipment, those items defined as 'no hazard' which are not used in operating or controlling the aircraft are considered to be excluded and therefore EASA Form 1 release certification is not necessary. A Certificate of Conformity is an acceptable means to support the identification of an item's authenticity

In consideration of whether the Regulation applies in this respect, the non-applicable 'no hazard' item must not:

- have any unsafe operating modes;
- have any unsafe failure modes (structural, electrical, system interface etc.);
- have any influence on the aerodynamics or flight characteristics or capabilities of the aircraft;
- be used to satisfy any airworthiness/certification or operational requirement.

Such non-required equipment could include items such as DVD players or role/mission equipment (not required for the safe operation of the aircraft) and may be approved for use within a permanent installation on a no hazard, no credit basis. The approved design organisation (DOA) must substantiate the no hazard determination of the item as part of its approved design data for its installation.

The DOA will also provide instructions for the continued airworthiness (ICA) of the equipment. This will constitute approved data that will detail the requirements for the installation, removal, test, and maintenance of the equipment. The ICA will also provide a means for an aircraft maintenance organisation to ensure that the equipment conforms to the expected design standard and that its no hazard status is retained.

4.7.3.2 Items of equipment that are predominantly based upon COTS articles that are not excluded as described in paragraph 4.7.3.1 may also be approved for aircraft use within a *permanent* installation, if it can be demonstrated during certification that the equipment complies with the applicable airworthiness and environmental requirements. Such equipment requires authorised release certification for installation. Eligibility for release on an EASA Form 1 as a 'manufactured' part by the approved production organisation (POA) could be achieved using the following process:

The DOA would typically produce a *specification* for the equipment, which is part of the approved installation data at aircraft level i.a.w. Part 21. This specification typically:

- prescribes an inspection process to ensure that the commercially sourced base equipment conforms to the expected design standard;

- takes due account of any potentially unsafe operating or failure modes of the base equipment and provides design change and/or test solutions to mitigate them; and
- identifies a new part marking scheme for the finished equipment.

The application of the specification to the COTS equipment effectively modifies the article, providing a means to release it on an EASA Form 1 as a manufactured item.

The DOA will also provide instructions for the continued airworthiness (ICA) of the equipment. This will constitute approved data that will detail the requirements for the installation, removal, test, maintenance and repair of the equipment. Compliance with the approved maintenance instructions will enable an appropriately approved maintenance organisation to release the maintained/repaired equipment, on an EASA Form 1 with the relevant block completed, as a repaired item.

It is recognised that the expertise to repair some COTS equipment will exist only within the equipment manufacturer's organisation. It is therefore necessary for the (aviation) approved maintenance organisation to ensure effective sub-contract oversight of the equipment manufacturer conducting such repair/maintenance activity, as required by 145.A.75. It is expected that the approved maintenance organisation will establish that the repaired equipment meets the DOA-approved standard on return from sub-contract repair, prior to completion of the EASA Form 1 release certification.

4.7.4 **Portable 'Attached' Equipment**

In the case where equipment is 'attached' or 'docked', but not permanently installed, an assessment will be required by the Design Organisation (DOA) to determine by test that the equipment does not present a hazard to the aircraft. This may include, but is not limited to, electromagnetic emissions and battery safety. Guidance exists for equipment in the following applications:

- | | |
|--|---------------------|
| • Electronic Flight Bag (EFB): | JAA TGL No 36 |
| • Use of PEDs Aboard Aircraft: | FAA AC-91.21-1B |
| • Use of Electrically Powered Medical Equipment on Aircraft: | CAAIP Leaflet 25-20 |

Unmodified COTS portable equipment (e.g. laptop, or MP3 player/Ipod) that is to be used on an aircraft is not eligible for Form 1 release. Part 21 Guidance Material GM21A.133 states that the manufacturer of parts identified as no hazard or industry supply are not at present eligible for Production Organisation Approval. A POA cannot normally release such an item on an EASA Form 1 as they will not normally have evidence of complete conformity to applicable design data (i.e. all of the specification data needed to manufacture and test the item as issued by a DOA holder) and therefore could not claim to have manufactured the part. In order to release on an EASA Form 1 the POA would also be required to assess the equipment manufacturer as a subcontractor and show that they were in complete control of the equipment manufacture.

The design of the attachment/docking method to the aircraft would be subject to the normal Part 21 design and change (modification) approval process.

4.7.5 **Portable Equipment/ Portable Electronic Devices (PEDs)**

A portable electronic device is one that operates from internal batteries or is plugged into an electrical supply (e.g. power outlet) designed for that purpose on the aircraft. Any item that is permanently connected into the aircraft is not a portable electronic device.

As with the portable 'attached' equipment, PEDs are not eligible for EASA Form 1 release. ANO Article 38(5) still applies and there is further guidance available in AIC 1/2004 (Pink 62).

For commercial operations, EU OPS 1.110 and JAR OPS 3.110 also require operators to ensure that the use of PEDs cannot adversely affect the performance of the aircraft's systems and equipment.

4.7.6 **Software Considerations**

In accordance with CAAIP Leaflet 100-10 paragraph 3.2, for Field Loadable Software (FLS) or Data Field Loadable Data (DFLD) files that are not required to meet a specific airworthiness or operational requirement /regulation or Certification Specification (e.g. CS-25), a Certificate of Conformity is sufficient.

5 **Distributors**

Although aircraft component distributors provide a useful service to the aviation industry they are not required to be approved by the CAA, cannot raise Authorised Release Documents and cannot be required to possess the necessary technical expertise to establish the status of aircraft components. It therefore follows that for all components received, the end user should request from the distributor the associated Authorised Release Document raised by an appropriately approved organisation as described above.

Where a distributor does not want to pass the component's documents to a potential buyer, being another distributor, it is acceptable for the original distributor's documentation to be endorsed:

'Authorised Release Documentation of the aircraft component is on file, Ref. No. # # # # and will be made available to the end user upon request from that end user.'

Upon request of the end user the distributor should transmit the original documentation to allow the end user to establish the component's acceptability prior to installation. In all cases it is the responsibility of the end user to obtain the appropriate Authorised Release Documentation and establish the acceptability of the component.

NOTE: Where more than one component appears on the Authorised Release Document and the components are to be distributed separately a certified true copy of the Authorised Release Document is acceptable for transmittal to the end user. It should be made clear which entries on the copy of the Authorised Release Document relate to the supplied components.

Leaflet B-120 Use of Standard Parts in Aircraft and Aircraft Restoration Projects

1 Introduction

This Leaflet has been raised to provide guidance on the use of standard parts in aircraft restoration projects and their subsequent maintenance. This Leaflet should be read in conjunction with the relevant aircraft manuals, manufacturers instructions, British Civil Airworthiness Requirements (BCAR) and CAP 562 Leaflet C-140.

2 Background

2.1 BCAR Chapter A4–8 prescribes procedures for the Design Approval of Aircraft Equipment and Accessories. In particular paragraph 3 refers to Standard Parts with a statement that BCAR A4–8 need not be followed for Aircraft General Spares (AGS) and other standard parts complying with National or International specifications or standards recognised by the CAA.

NOTE: This is intended to cover minor items complying with AGS, SBAC, BSI or similar standards, where these are limited to manufacturing drawings from which the approved Organisation can assess the items as suitable for the intended application.

2.2 From time to time, whilst carrying out aircraft restoration projects usually associated with vintage aircraft, the standard parts, or AGS of the original design standard are no longer available. To enable the project(s) to be concluded successfully, there are methods and procedures required to be followed by the restorer(s) for the use of alternative parts of AGS.

3 Critical/Non Critical Nature

3.1 In the context of this Leaflet the term 'Critical Nature' is used to describe any bolted joint or attachment where stress levels are high and where inadequate assembly techniques or inappropriate fasteners could result in fatigue or catastrophic failure of the structure. Examples of critical nature joints are:

- a) Spar or wing attachment joints
- b) Fin/tailplane attachment joints
- c) Engine/strut mounting structure
- d) Flying control systems or surface attachments

3.2 In the context of this Leaflet the term 'Non Critical Nature' is used to describe any attachment or fastener of ancillary structure or fairings which are not critical to the airworthiness of the aircraft or structure. Examples of fasteners or attachments of a non critical nature are not exhaustive but could be associated with:

- a) Fairings
- b) Cabin interior furnishing
- c) Panel attachment

4 Alternative Parts

- 4.1 **Standard Parts – Critical Nature** Standard Parts which are replaced by those of equal or improved specification with regard to dimensional tolerances and material properties, can only be embodied by modification procedure in accordance with the requirements of BCAR A/B2-5, or be in accordance with the product support publications of the aircraft Type Certificate holder or Type Design (See CAP 562 Leaflet B-90).
- 4.2 **Standard Parts – Non Critical Nature** Where the manufacturer's airworthiness data permits, it is acceptable to replace original standard parts used in areas of a non critical nature with items of equal or improved specification with regard to dimensional tolerances and material properties, without the need for CAA involvement. In all other instances the requirements of BCAR A/B2-5 are applicable.

Leaflet B-130 The Problem of Bogus Parts

1 The CAA is becoming increasingly concerned about the quantity and variety of unapproved parts which are finding their way on to UK registered aircraft, in particular helicopters. Evidence indicates that these counterfeit and/or fraudulently identified parts are being imported, largely from North America; however, the CAA also has evidence of such bogus parts originating from the UK and also other foreign sources.

1.1 Manufacturing and/or marketing bogus parts is not endemic to the United Kingdom but evidence of the falsification of release documentation (Form One or equivalent) has been observed.

1.2 Installing bogus parts onto aircraft has serious airworthiness implications; to illustrate just how serious, the following two examples are quoted involving aircraft which are available in the international market place:

a) A helicopter main rotor blade complete with release documentation was traced as having been scrapped by the manufacturer during the manufacturing process.

b) An engine mount described as fitted new to an aircraft in 1979 was traced as having been factory installed in 1966.

2 Unapproved Part For the purpose of this Leaflet an Unapproved part is a part or material intended for installation on a type certificated product/aircraft, which has been neither manufactured according to approved procedures, nor conforms to an approved type design; or it fails to conform to declared specifications or accepted industry standards (i.e. standard parts).

2.1 Unapproved parts include, but are not limited to:

a) Parts specified in the illustrated parts catalogues (IPC) of a type certificated aircraft, but which have been manufactured, reclaimed or reworked and then marked by an unauthorised source and provided with documents which indicate falsely that the part(s) are genuine and conform to the approved type design, or meet a particular industry standard and are offered for use as conforming with an aircraft manufacturer's authorised IPC.

b) Parts shipped directly to users by manufacturers, suppliers, or distributors who do not themselves hold appropriate production approvals for the parts, and have not been authorised to make direct shipments to users or stockists by the Type Certificate holder, who alone has production approval, e.g. production overruns. This is a particular phenomenon in the United States.

c) Parts which have not been maintained, overhauled or repaired in accordance with the requirements of approved airworthiness data and/or statutory requirements, or that have been maintained, overhauled or repaired by persons not authorised to perform and certify these functions.

3 FAA Suspect Unapproved Parts Notifications

3.1 The FAA and CAA have intensified efforts to educate the public regarding the potential safety threat posed by aeronautical parts that do not meet applicable design, manufacturing or maintenance requirements. To achieve this, the FAA established a Suspect Unapproved Parts programme (SUPs) and issued guidance in an Advisory Circular 21-29B.

3.2 Suspect Unapproved Parts Notifications can be found on FAA Internet site: www.faa.gov/about/office_org/headquarters_offices/avs/offices/sup/

4 Because of the increased activity being undertaken in the United States against suspect unapproved parts, it is likely that the vendors of these parts will direct their activities towards Europe and other parts of the world because of the reduced risk of detection.

5 Mandatory Occurrence Reporting Procedures

5.1 Users of aircraft components and spares are reminded that suspected unapproved parts should be reported to the CAA through the Mandatory Occurrence Reporting (MOR) procedures.

5.2 Although the MOR procedure does not extend to piston engined aircraft used for Aerial Work or privately operated, and any aircraft with a Permit to Fly, users of aircraft parts or material for this class of aircraft are encouraged to use the procedure where suspect parts are identified.

5.3 On receipt of an MOR, and where appropriate, the CAA will pass the details to the FAA SUPs office by the submission of a SUPS Report. In addition to assisting the FAA, who are implementing a vigorous campaign against unapproved parts, this procedure will enable the CAA to establish the dimensions of the problem as it affects the United Kingdom.

5.4 To assist in tracing unapproved parts or material, persons raising an MOR should, as far as possible, provide the following information on their report:

- a) The name of the suspected unapproved part.
- b) Part number, or any other number on the part.
- c) Serial number of part.
- d) List next higher assembly that suspected unapproved part is assembled into (i.e. fuel pump, engine, landing gear) and list part number, if known.
- e) Quantity of suspected unapproved parts found or identified.
- f) Make and model number of the aircraft or component that the suspected unapproved part is applicable to.
- g) The identification of the commercial source of the suspected unapproved part. If the part is identified with Part Manufacturer or Distributor marking, this should be quoted.
- h) Describe any pertinent facts relating to the suspected unapproved part and identify where part may be inspected (provide photos, invoices, etc., if available).
- i) The date suspected unapproved part was discovered.
- j) Name and address in full or the location where suspected unapproved part(s) was discovered.

5.5 In accordance with normal protocol for confidentiality any SUPS report submitted to the FAA would not give details of the MOR reporter.

6 Foreign aircraft and approved component manufacturers can be contacted by users through their UK agent or direct, for verification that specific serial numbered items purported to be manufactured by them are in fact recorded in their archives. As an example, this process was used to verify that a particular helicopter main rotor head was in fact bogus.

7 The Certifying Person and User Responsibility

- 7.1 The Certifying Person (User) can be either the Approved Organisation, a person authorized in accordance with that organisation's Exposition, or an appropriately CAA Type Rated Licensed Engineer, who issues the Certificate of Release to Service for installation of an aircraft part into an aircraft, its engine(s), propeller(s) or equipment.
- 7.2 The User of an aircraft part is responsible for ensuring that the part is serviceable and conforms to the standard determined by the appropriate Type Certificate holder as being suitable for the intended application. In order to discharge this responsibility to the satisfaction of the CAA/EASA, the user must, when obtaining an aeronautical part from a supplier:
- a) Ensure that the purchase order contains accurate definition of the aircraft parts and full details of the quality control and certification requirements to be met by the supplier in satisfying the order;
 - b) Take all necessary steps to verify that the supplier is meeting the requirements of the purchase order. This may require the user visiting the supplier's facilities.
- 7.3 In order to contain the serious problem of unapproved parts, Commercial Air Transport Operators and associated Maintenance organisations who are users of aircraft spares should ensure that their aircraft spares purchasing policy and procedures are unequivocally stated in their company expositions/engineering procedural documents. They should also ensure that any deviation from that policy must be approved by the quality manager in accordance with procedures acceptable to the CAA.
- 7.4 Other organisations and private owners who purchase aircraft parts or materials can only be advised to exercise extreme caution and remember they will have to convince the user of the authenticity of such spares.
- 8** CAP 562 Book 1, Leaflets B-100, B-110, C-140 and Book 2, Leaflet 70-20 provide further information on the acquisition of parts and materials for use in aircraft.

INTENTIONALLY LEFT BLANK

Leaflet B-140 UK Certificate of Airworthiness Issue for Series Aircraft at the Manufacturer's Premises in the USA

1 Introduction

This Leaflet is issued to provide guidance material to assist applicants in meeting the requirements for the issue of a Certificate of Airworthiness for a Series Aircraft being certificated at the manufacturer's premises in the USA.

1.1 References:

BCAR Section B Chapter B3–3.

1.2 This Leaflet supersedes and cancels Leaflet AD/IL/0142/1-7 dated 21 May 1990, which should be destroyed.

2 This Leaflet is issued to assist applicants in meeting the requirements for the issue of a Certificate of Airworthiness for a Series Aircraft being certificated at the manufacturer's premises. It also satisfies industry's request for a more definitive standard of documentation for the CAA Surveyor, to relieve the aircraft manufacturer of difficulties when dealing with requests from individual Surveyors.

3 The Certificate of Airworthiness issue process is not a rigid procedure and Surveyors will be free to call for more detailed assessment and scrutiny of the production and flight test documents associated with the Certificate of Airworthiness issue, should they have reason to believe there is a need.

4 In addition to the checks carried out by the Surveyor, the Applicant/Owner/Operator's own monitoring of the manufacturer's controls and standards in the production of the particular aircraft is important and will have a significant impact on the depth of investigation and overall confidence level established by the Surveyor.

5 Where the Applicant/Owner/Operator does not have resident engineers at the manufacturers, or support from another airline's resident engineering staff, the Surveyor will inevitably become more involved with the manufacturer and the extent of the investigation of the build standard will be more protracted than had the Applicant's own assessors been involved.

6 In order that the Applicant/Owner/Operator is aware of what is required from the manufacturer for the issue of a (Certificate of Airworthiness), the Check List shown in Appendix No. 1 has been prepared. It is essential that a single specific point of contact is established at the manufacturer's facility for liaison purposes.

7 The Check List primarily addresses Boeing products and uses Boeing terminology (see Appendix No. 2). It is, however, generic to other US manufacturers' products and may be used with these manufacturers subject to adjustments being made to the certification document terminology used.

7.1 However, the Surveyor must be satisfied that the aircraft is wholly in compliance with the relevant EASA requirements. FAA Advisory Circular AC 21-2(k) entitled 'Export Airworthiness Approval Procedures' refers.

NOTE: Should the need arise, the requirements and principles referred to in this Information Leaflet may be applied to European Manufacturer's Products.

INTENTIONALLY LEFT BLANK

Appendix 1

CAA CERTIFICATE OF AIRWORTHINESS ISSUE CHECK SHEET – SERIES AIRCRAFT

The following items are required **from the operator** by the Surveyor for Certification and/or review:

- 1 Tab No. Customer No. Serial No. UK Registration
- 2 FAA Export Certificate of Airworthiness. (DC)
- 3 Letter from Manufacturer stating compliance with: (DC)
 - a) FAA ADs.
 - b) EASA Airworthiness Directives.
 - c) CAA Mandatory Modifications and Inspections (Reference UK Manufactured Equipment installed).
 - d) Manufacturer's Statement of Compliance with CAP 747 Mandatory Requirements for Airworthiness.
 - e) Manufacturer's Statement of Compliance with EASA Generic Requirements.
- 4 Confirmation of Item 3 (a)–(e) relating to Engines (DC) and APU. (AW)
- 5 Engine State of Design Directives.
- 6 Log Books for Airframe, Engines and APU. (DC)
- 7 FAA Approved Flight Manual.
- 8 Weight and Balance Manual. (DC)
- 9 Copy of Interior Certification Drawing as provided to FAA showing a pictorial presentation of the aeroplane cabin interior as approved for compliance with FAR Part 25. (DC)
- 10 Flight Test Defect Reports and Rectification Action. (DC)
- 11 Confirmation that the aircraft is no longer registered in the USA. (AW)

The following documents are to be obtained by the operator prior to certification and made available to the Surveyor:

- 1 Statement of Build Standard.
 - a) Detailed Specification Document. (CE)
 - b) Master Change Listing. (CE)
 - c) PRR Listing (at time of delivery) or update since last CAA aircraft. (CE)
 - d) Service Bulletin applicability standard. (AW)

- 2 Electrical Load Analysis. (Differences only between delivered aircraft and first aircraft certificated) (could be received within one month). (AW)
- 3 Compass Check Certificate. (DC)
- 4 Radio Equipment List. (AW)
- 5 Software Criticality Listing showing affected Part Numbers. (AW) or (CE)

NOTES: 1 Where aircraft are required to meet the requirements of Schedule 4, scales P or S, of the Air Navigation Order in respect of Flight Data Recorders, the Applicant/Owner/Operator should ensure on acceptance of the aircraft, that they are in possession of all the appropriate information pertaining to the conversion data necessary for obtaining an accurate and comprehensive read out from the FDR.

2 The Applicant/Owner/Operator should also ensure that the FDR system is fully functional and capable of producing a comprehensive read out at the time of the Certificate of Airworthiness issue.

Appendix 2

BOEING AIRCRAFT

Build Standard – Boeing 'build standard' at delivery is determined by a number of different types of customer defined configuration items and Boeing defined items. The individual aircraft Detailed Specification is comprised of the following items:

Standard Options (SO) – These are options available to the customer as part of the 'standard aeroplane'. Example – Gravier or Systron-Donner fire detection.

Standard Changes (CH) – These are not an 'A' or 'B' selection, rather a change to the equipment that is Boeing standard. Example – Esso/Exxon 2380 oil in lieu of Mobil Jet II oil.

Change Request (CR) – A change request is requested by the customer when a desired configuration is not available from the standard options and changes. Examples of this might be a new interior arrangement or selection of equipment not previously certified for use on the particular aircraft.

Committed Changes – Once the detailed specification has been closed, the only way to revise the configuration of the aircraft is by committed change. All changes must have the approval of the Chief Engineer. The changes are committed on a Change Board that has representatives from all affected organisations. Once a change has been committed, the commitment cannot change without the full consent of all members of the Change Board. Any of these changes can supersede another.

Master Changes (MC) – Customer requested changes that occur after the detailed specification has been closed.

Production Revision Record (PRR) – Boeing initiated changes. Product improvements, new suppliers, design errors, etc. The PRR listing is in two types: Type I is given to the customer, Type II will be made available on request to the certifying regulating Authority.

Rapid Revision (RR) – Rapid Revisions are the only type of change document that is a drawing. They are generally used for last-minute changes, usually customer initiated.

Please be advised that the PRR listing that is supplied is to be used as a tool to evaluate an aeroplane's configuration. If the listing compares two aircraft and the change is on both, it will not appear. The database is not guaranteed to be 100% accurate. Drawings are the only method to define what is to be installed on any aircraft.

Boeing Certification Documents are supplied from three centres:

The Delivery Centre (DC)	– Renton (NB) Everett (WB)
The Airworthiness Office (AW)	– Renton (NB) Everett (WB)
Customer Engineering (CE)	– Renton (NB) Everett (WB)
(NB) Narrow Bodied Aircraft	
(WB) Wide Bodied Aircraft	

Aircraft Flight Manuals, Engine Log Books and the Readiness Log are held by the Delivery Centre Records Offices. These documents will be released to the customer on releasing day. They are however available for scrutiny.

- NOTES:**
- 1) Liaison with Customer Engineering as a prime source of assistance is advised.
 - 2) Local variations in procedures between the Renton and Everett facilities may be encountered.

Leaflet B-150 Safety Critical Maintenance Tasks

- 1** A factor in a serious incident involving an oil leakage on a large twin engined commercial air transport aircraft was the failure to re-install the drive cover plate on both engines following maintenance. The CAA wishes to highlight the potential safety benefit where companies choose to apply aspects of Extended Range Twin Operations (ETOPS) maintenance philosophy to multi-system aircraft in order to avoid the possibility of simultaneous incorrect maintenance on two or more safety critical systems. In this context, such systems are those which have a fundamental influence upon the safe operation of the aircraft, engines and their systems being a case in point.
- 2** Operators and maintenance organisations should consider the following paragraphs when planning, and accomplishing scheduled and non-scheduled maintenance tasks on multi-system aircraft.
 - a) Arrangements should be made to stagger scheduled maintenance tasks on essential or primary systems such that the accomplishment of similar critical tasks on two or more systems are segregated. Consideration should be given to introducing procedures that will ensure that such tasks are separated by at least one flight cycle. Where it is not practical to introduce staggered maintenance, inspections and functional checks should be performed independently to ensure system serviceability.
 - b) Where it is not practical to introduce staggered maintenance at Base Maintenance inputs or during rectification of Line or Base defects, the use of separate work teams together with the accomplishment of appropriate functional checks to verify system serviceability should ensure a similar level of system integrity.
 - c) Procedures should be established to provide maintenance and planning personnel with guidance on the identification and accomplishment of safety critical tasks conducted during scheduled and non-scheduled maintenance activities. Routine task documentation should identify those tasks which may have a critical effect on safety and should clearly identify the individual stages of such tasks. Maintenance Programme or Maintenance Schedule basic rules should provide the necessary standards to ensure the identification of critical scheduled maintenance tasks.
- 3** Maintenance personnel's initial and continuation training should highlight the critical nature of conducting maintenance tasks on essential or primary systems. The instruction given should provide personnel with the necessary information to identify and satisfactorily accomplish such tasks. Training programmes should focus on safety critical tasks and the possible consequences of failure to follow the associated maintenance procedures. The development of these training programmes should use feedback from maintenance experience, to enhance the programme and maintenance procedures.
- 4** The CAA considers that the intent of this Leaflet provides a basis for organisations to adopt good maintenance practices for multi-system aircraft.

INTENTIONALLY LEFT BLANK

Leaflet B-160 Maintenance Error Management Systems

This is Proposed AMC to Part 145.A.60

1 Introduction

- 1.1 There can be no argument that a maintenance error has the potential to create an unsafe condition on an aircraft. It is recognised that human beings, who are an important and key part of the aircraft maintenance regime, are not infallible. The possibility of a maintenance error is dependent upon a number of factors, including the way in which individuals carry out their work. The probability and consequences of maintenance error are however largely unpredictable. Their effects may be noticed immediately or may sit as a latent threat until a much later date, possibly coming to light only after the failure of another system or component exposes the weakness the error has created.
- 1.2 It is important for maintenance personnel at all levels to be aware of the potential for error that exists. This can be achieved by better understanding the limitations of human performance and managing the circumstances that may lead to errors being made. Whilst the aim must be to prevent such errors being made in the first place, it is essential that organisations, and the individuals within, learn from the actual events or close calls that may arise from errors being made. This is a key element of an organisational safety management system (SMS).
- 1.3 For the purpose of this Leaflet a maintenance error is considered to have occurred when the maintenance system, including the human element, fails to perform in the manner expected in order to achieve its safety objectives. A pictorial representation of the 'maintenance system' is shown below.

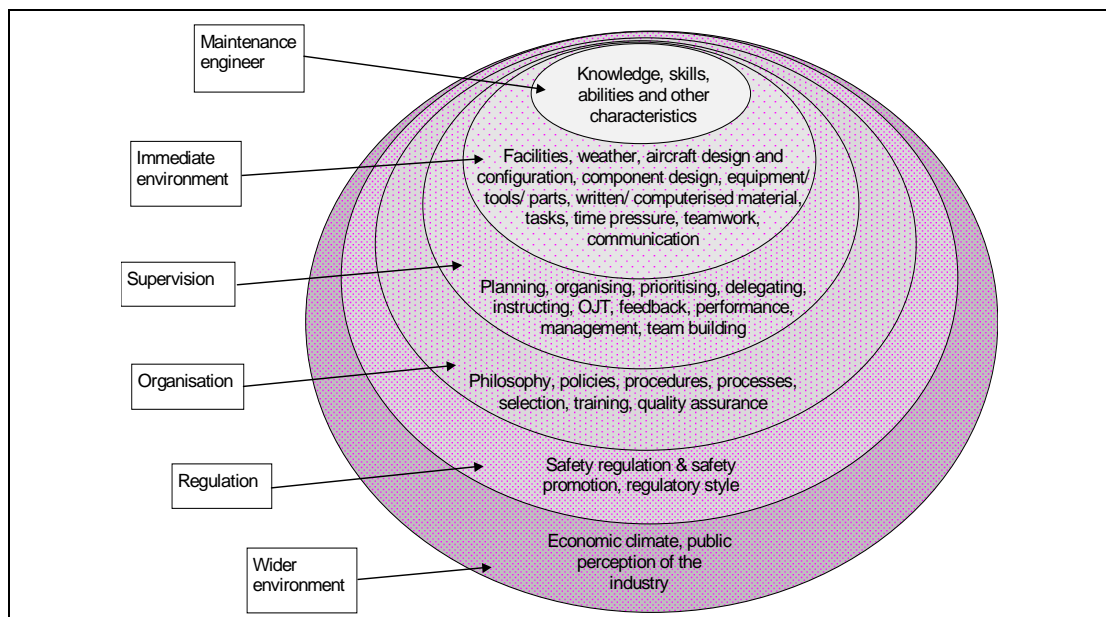

Figure 1 The maintenance system. Source: Boeing, adapted by Baines, 2001¹

1. Baines, K. (2001) Training Material: Influences on the Maintenance System, UK CAA.

- 1.4 This Leaflet addresses the concept of maintenance error management systems through the identification and investigation of maintenance related errors. It also lays out the CAA's expectations as to how such information should be collated and shared so that aviation safety may be improved through the collective experience of the industry. It is important to examine not just **what** happened but, more importantly, **why** it happened in order to determine the root causes and allow us to identify a strategy that reduces, or ideally eliminates it from occurring again.

2 The Requirements

- 2.1 In today's operating environment, organisations are expected to have in place an effective SMS to manage the hazards and risks that are inherent in any operation. Whilst the scale and size of the SMS will vary according to the complexity and scale of an organisation's activities every company should develop safety improvement strategies to support its SMS system and policies. However, in order to do so it must have information about the issues to target. It is important therefore to have knowledge of the changing hazards, risks and any failures in the company's system or working practices in order that changes can be managed or remedial action put in place.
- 2.2 Part 145.A.60 places an obligation on maintenance organisations to "establish an internal occurrence reporting system". The purpose of such a system is to enable the collection and evaluation of information regarding events which have resulted, or may have resulted, in an unsafe condition that affects flight safety. There are equivalent reporting requirements in the other EASA implementing rules, e.g. Part M.
- 2.3 The internal occurrence reporting procedures under Part 145.A.60 shall seek to identify adverse trends, the corrective actions taken to contain an unsafe situation or to be taken by the organisation to address deficiencies and include evaluation of all known relevant information relating to such occurrences and a method to circulate the information as necessary. This clearly suggest that, notwithstanding the need to formally report occurrences to the various agencies, the organisation is expected to carry out internal investigations, not only against an individual occurrence but looking for possible correlation between events and any underlying trends.
- 2.4 The reporting of occurrences is essential to the improvement of air safety by ensuring that relevant information on safety is reported, collected, stored, protected and disseminated. Although the CAA already had a reporting system, European Directive 2003/42/EC introduced additional requirements for the UK to establish an occurrence reporting system for civil aviation that fed into a Europe wide system. This Directive has been enacted by amendment of the UK Air Navigation Order (ANO) 2009 (as amended), modifying the existing legislation that addressed the UK Mandatory Occurrence Reporting (MOR) System.
- 2.5 Section C of Annex I to the Directive prescribes the typical incidents that are required to be reported. The issue of maintenance error is included in the scope of these reports, including instances of non-compliance or significant errors in compliance with required maintenance procedures. The Annex provides detail on what sort of events must be reported and these are subtly different from those under the previous provisions of the CAA MOR system.
- 2.6 The collation of incident data will be managed through the European Coordination Centre for Aviation Incident Reporting System (ECCAIRS). In the longer term, this will enable EASA and the EU Member States to have greater visibility about safety data in Europe and the key risks and threats.
- 2.7 Part 145.A.65 further requires an organisation to establish a safety and quality policy for the organisation. This should extend into the development and publication of working procedures which take account of human factors principles and human performance. This is very much focused upon the need to avoid putting the individual into a situation where they are pressurised, whether real or perceived, into working outside of the published requirements. However, the requirements also focus upon encouraging personnel to report maintenance related errors/incidents and for the company to analyse previous experiences of maintenance errors.

3 Maintenance Error Management Systems

- 3.1 As noted above, a Maintenance Error Management System (MEMS) should be an inherent element of any organisation's SMS. It partially satisfies the intent of Part 145.A.60 for internal reporting systems, although there will still be reportable technical failures that are not attributable to maintenance error. More importantly, MEMS creates a means of identifying areas of weakness for the organisation to address. The organisation should also seek to promote and cascade out safety guidance to its staff on how to prevent such errors and to promulgate the potential pitfalls that led to the event. These should somehow be captured and offered to the wider community so that everyone can learn from the collective experience that accumulates, not the one company alone. These systems, and the information that they provide form an important element of the UK's State Safety Programme.
- 3.2 The CAA wants industry to provide an environment and underpinning culture whereby maintenance errors may be openly reported by staff and investigated objectively in order that the contributing factors and root causes of such errors can be addressed. The organisation's MEMS system should complement the existing systems for reporting occurrences under the CAA MOR scheme by looking at the error events in greater detail, the associated underlying circumstances and the root causes with the intention of identifying appropriate corrective actions that are appropriate and effective.
- 3.3 The Confidential Human Factors Incident Reporting Programme (CHIRP) scheme provides an alternate reporting mechanism for individuals who want to report safety concerns and incidents confidentially. However CHIRP should not be considered as an alternative to MOR reporting, which has its own 'confidential' reporting provisions, or to implementing a Maintenance Error Management System (MEMS) scheme. MOR, MEMS and CHIRP perform different functions albeit acting towards the same ultimate aim, i.e. improved flight safety.
- 3.4 Maintenance errors with serious consequences such as accidents or incidents are often routinely investigated by bodies external to the organisation, such as the Air Accidents Investigation Branch. However, such involvement should not prevent the organisation itself carrying out a MEMS investigation into an occurrence. There will inevitably be actions which should be looked at and addressed whilst the external investigation proceeds. Whilst there may be an overlap between the functions of the investigation the company must remember that it has to investigate and address the shortfall that resulted in the event.
- 3.5 Operationally significant events (e.g. technical delays, cancellations, etc.) may not be legally required to be reported externally but are frequently investigated by organisations, albeit only to apportion responsibility for the event, and to track its consequences rather than specifically to determine cause. Below these levels are events without operational significance (e.g. the omission of an oil filler cap which, by chance, is noticed and corrected before flight), which may rarely be investigated. Many of these, whilst relatively innocuous on their own, are examples of where the system has failed but, due perhaps to chance, the failure has been caught. These should not be ignored.
- 3.6 In order to gain a better understanding of the problems and the contributory factors, including human factors and performance, company procedures and maintenance manual errors which contribute to such occurrences it is necessary to investigate these before they possibly contribute to or cause an incident or accident in the future.

4 MEMS Policy

- 4.1 The concept of MEMS and the associated investigative techniques have been around since 2002. The principles were proven and incorporated into the requirements of JAR-145 and further guidance promulgated via a CAA Airworthiness Notice. However, with the advent of SMS and its wider application across all of an organisation's functional areas, it is important that an organisation's MEMS policy and procedures be revisited, as with any procedure, to ensure that it remains fit for purpose. Organisations that do not have a MEMS process should look to establish one within the provisions of their SMS. Those organisations that already have a MEMS process should look at it to see if it is adequately identifying the underlying root cause and whether suitable corrective actions are being taken and the success of those actions monitored.
- 4.2 Prevailing industry best practice over the last ten years has shown that a MEMS should contain the following elements:
- A cascade of policy from the organisation's Safety Policy and SMS that clearly establishes MEMS;
 - Demonstrable corporate commitment with management roles and responsibilities for MEMS clearly defined;
 - Clearly identified aims and objectives of the MEMS programme;
 - Corporate encouragement of uninhibited reporting and participation by individuals;
 - Establishment of a just culture, with clear guidance on disciplinary policies and the associated boundaries identified and published;
 - Identification and publication of the events that will typically trigger error investigations;
 - An event investigation process which results in the establishment of root cause;
 - Investigators selected and trained, including where appropriate training in investigative tools such as MEDA (Maintenance Error Decision Aid);
 - MEMS overview education for staff, and more in-depth training for maintenance staff where necessary;
 - Appropriate action to address root cause and the associated safety concerns based on investigation findings, including monitoring of its effectiveness;
 - Feedback of results to workforce, including where appropriate use of examples during continuation training;
 - Feedback from the continuation training into the organisation's Quality system;
 - Analysis of the collective data within the organisation showing contributing factor trends and frequencies.
- 4.3 The aim of the scheme is to identify the factors contributing to incidents, and to make the organisation's system and working practices resistant to similar errors. Whilst not essential to the success of MEMS, it is recommended that for large organisations that a computerised database be used for storage and to assist in the analysis of the collated MEMS data. This would enable the full potential of such a system to be utilised in managing errors.
- 4.4 A database of the result of error investigations is currently held and maintained by CHIRP (UK-MEMS), the intention of which is to carry out periodic analysis of the detail within the investigation reports, the underlying causal factors and trends so that

action can be taken across the industry collectively to address any particular issue. CHIRP has worked with the CAA MOR database to correlate the information in the first ten years of the scheme so that industry can be provided with the key themes arising from the analysis. It is important therefore that all organisations contribute by submitting MEMS reports so that industry wide trends can be identified.

- 4.5 The human element includes technicians, engineers, planners, managers, store-keepers – in fact any person contributing to the maintenance process. The foregoing definition differs from that of a human error as it demands consideration of the system failings (e.g. inadequate staffing, organisational factors, tooling availability, ambiguous manuals etc.) as well as the error committed by a person.

5 MEMS – Organisational Procedures

- 5.1 An organisation should put supporting procedures in place to deliver its MEMS policy. These should set out the reporting and MEMS management processes as well as outlining how the organisation intends to carry out investigations, compile reports and feed any findings back into the organisation's SMS and management system.
- 5.2 A maintenance error should be reported through the company's internal system and, if meeting the criteria, also submitted as an MOR in order to comply with the ANO provisions.
- 5.3 The extent of the investigation will depend upon the nature of the event, the size and the complexity of the organisation (e.g. multi-site, complex procedures, shift working). Small organisations may employ a relatively simple investigative process but should endeavour to use independent staff to carry out the investigation. Larger organisations may wish to use a more formal process with trained investigators and a tool, such as MEDA, to help to manage the investigation and ensure that it uses an appropriate degree of rigour.
- 5.4 Where an occurrence reported via MEMS indicates an unpremeditated or inadvertent lapse by an employee, as described below, the CAA would expect the employer to act reasonably. It is important that the organisation accepts that free and full reporting is the primary aim in order to establish **why** the event happened by studying the contributory factors that led to the incident, and that every effort should be made to avoid action that may inhibit reporting. This is why the establishment of a just culture is essential.
- 5.5 In the context of error management it is considered that an unpremeditated or inadvertent lapse should not incur any punitive action, but a breach of any expected professional conduct may do so. It is also important to realise that, until the investigation is complete, the individual may not be solely to blame as systemic factors or procedural failures may be a contributory factor.
- 5.6 As a guideline, individuals should not attract punitive action unless:
- a) the act was intended to cause deliberate harm or damage;
 - b) the person concerned does not have a constructive attitude towards complying with safe operating procedures;
 - c) the person concerned knowingly violated company or regulatory procedures that were readily available, workable, intelligible and correct;
 - d) the person concerned has been involved previously in similar lapses;
 - e) the person concerned has attempted to hide their lapse or part in a mishap;

f) the act was the result of a substantial disregard for safety.

“Substantial disregard”, for this purpose, means:

- In the case of a certification authorisation holder (e.g. licensed engineer or Certifying Staff but also applicable to base maintenance support and other authorised staff) the act or failure to act was a substantial deviation from the degree of care, judgement and responsibility reasonably expected of such a person.
- In the case of a person holding no maintenance certification responsibility, the act or failure to act was a substantial deviation from the degree of care and diligence expected of a reasonable person in those circumstances.

g) it can be proven that the person knowingly reported for work in an altered mental or physical state rendering the individual unfit for safe duty.

5.6.1 The degree of culpability would vary depending on any mitigating circumstances that are identified as a result of the MEMS investigation. It follows that any action taken by the organisation would also be on a sliding scale varying from corrective measures such as retraining through to dismissal of the individual.

5.7 In the case of incidents investigated via MEMS, irrespective of whether or not such incidents were brought to the knowledge of the CAA, the CAA expects an organisation to address the problems which contributed to these incidents. The organisation should, where possible, implement appropriate measures to prevent the problem from re-occurring, or alternatively monitor future occurrences, according to the degree of risk and likelihood of re-occurrence. A supporting database is useful in these circumstances in helping to assess the frequency of occurrence and any associated trends.

5.8 The CAA would expect that identified safety issues would be acted upon. There may be immediate actions required to address an unsafe situation with longer term actions following on from the results of the investigation. If the CAA becomes aware, by whatever means, that a significant safety problem existed and was not being addressed, it reserves the right to take appropriate action.

NOTE: The statement by an organisation that an incident is undergoing, or has undergone, a MEMS investigation, without any additional information provided to explain why the incident occurred, would not normally be an adequate basis for an MOR closure.

6 CAA Action

6.1 The CAA will be checking, as part of its approved organisation oversight process, that an organisation’s internal occurrence reporting and investigation process is functioning as described in the procedures approved by the CAA and in line with the objectives of the programme as explained in CAP 716. The CAA audit may involve the review of MEMS investigations such that the foregoing can be satisfied. However, the CAA makes the following assurances that it will:

- a) subject to b) not disclose the name of the person submitting the MEMS report, nor of a person to whom it relates, nor pass on a MEMS report to a third party, unless required to do so by law or unless the person(s) concerned authorises such disclosure.
- b) take all reasonable steps possible to avoid disclosing the identity of the reporter or of those individuals involved in the occurrence, should any follow-up action arising from a MEMS report be taken.

- c) not, as its policy, institute criminal proceedings in respect of unpremeditated or inadvertent breaches of the law or requirements, which come to its attention only because they have been reported under the MEMS scheme, except in cases involving dereliction of duty amounting to gross negligence or recklessness. Such an assurance is similar to that provided under the MOR scheme.

6.2 As examples of what the CAA might require, as evidence that an organisation has a working MEMS programme in accordance with Part 145.A.60(b), a surveyor may ask to see the following documents and evidence, and in order to satisfy himself, he may wish to speak to individual members of staff at any level within the organisation:

- a) A copy of the company's safety and disciplinary policy and determine that staff are aware of this policy, and believe that it will be, and has been, applied fairly;
- b) The procedure describing the company's process for reporting and investigating incidents and errors, and the types of occurrences that would normally be investigated;
- c) Evidence that occurrences meeting the criteria detailed above have been reported, and to assure himself that occurrences are not frequently going unreported;
- d) Evidence that occurrences meeting the criteria detailed above have been investigated, and to assure himself that occurrences are being, and have been, fairly investigated. It is hoped that an organisation would cooperate with a surveyor in putting him in touch with individuals who have been party to investigations, but only with the agreement of the individuals concerned;
- e) Within a large company, evidence that MEMS investigators had received appropriate training;
- f) Evidence that the organisation had acted, or was acting, upon results of MEMS investigations, based on risk assessment. This may mean that no action had been taken if a risk assessment has deemed that the causes were unlikely, in isolation or in combination, to result in a hazardous event in the future. A surveyor would expect to see evidence of action(s) to prevent root causes, and/or to mitigate the effects of error where appropriate;
- g) Evidence of feedback to the workforce, on both occurrences and their investigation, and remedial action taken, would also be expected.

6.3 For a small organisation, the surveyor would expect evidence as described above, but on a less structured basis.

6.4 If an organisation has no evidence to offer in the form of reported and investigated occurrences, the surveyor may wish to talk to staff to assure himself or herself that there have been no such occurrences, as opposed to occurrences going unreported and un-investigated. The surveyor would respect staff confidences in seeking such evidence.

7 Further Information

7.1 Maintenance Organisations requiring further information or advice on how to establish a Maintenance Error Management System should contact their CAA Airworthiness Evaluation and Surveillance Department local Regional Office; or

Airworthiness Evaluation and Surveillance Department

Chief Surveyor's Office

CAA

Aviation House

Gatwick Airport South

West Sussex

RH6 0YR

Tel: 01293 573366

Fax: 01293 573984

INTENTIONALLY LEFT BLANK

Leaflet B-170 CAA Use of Confidential Information

1 Introduction

1.1 The Air Navigation Order places a duty on the CAA to consider:

- a) the design, construction, workmanship and materials of aircraft and their associated equipment; and
- b) the results of flying trials and such other tests as are necessary;

when it is satisfying itself that aircraft registered in the UK are fit to fly. In carrying out this duty the CAA, as it is empowered to do, makes extensive use of reports furnished to it by appropriately qualified persons.

1.2 Such reports may come in various forms and have a range of purposes. They may provide a physical description of anything from a complete aeroplane to a small item of equipment. They may specify performance or present test results. They may demonstrate that certain design or manufacturing standards are met.

2 CAA's Use of Such Information

2.1 However it is presented, the CAA's interest in such information stems from its need to be satisfied that a given aircraft or aircraft type is fit to fly. Once satisfied, if the CAA is subsequently presented with another aircraft (or item of equipment or operating proposal etc.) which it knows to be identical in nature it cannot and should not ignore this state of knowledge and insist that the person seeking approval goes through the whole process of satisfying the CAA again.

2.2 The CAA is aware that there may be commercial implications to the policy described in paragraph 2.1, in that second or subsequent applications for a given approval may derive substantial benefit from the evidence provided when the first application was cleared. Technical data are frequently submitted with notes purporting to place restrictions on their use and it is possible that undue significance may be attached to such notes. One purpose of this Leaflet is, therefore, to make it clear that when an aircraft or item of equipment has once been shown fit for a particular purpose, the fact has been established: the CAA does not need to demand repetitive evidence from a later applicant for an identical certification and will not ask for it. The onus is, of course, upon such an applicant to demonstrate that the relevant circumstances are identical.

2.3 If safety depends on the way in which an aircraft (or item of equipment etc.) is used, the CAA may have considered and approved certain proposed operating limitations, or it may have required evidence that established operating procedures are acceptable; if so, it may require similar material to be provided by subsequent operators seeking a similar clearance. This is, however, a separate matter.

3 Confidentiality of Proprietary Information

3.1 It is no contradiction of the principles in paragraph 2, to state that subject to the specific provisions in the Civil Aviation Act, the CAA totally accepts prohibitions placed by the owners of information on its disclosures to third parties. Thus, if an aircraft requires modification in order to satisfy a design requirement, no details of a proprietary modification would be passed on by the CAA to a third party without the

express permission of its owners. Nor, if an operation depended upon certain proprietary Flight Manual limitations or data, would such information be passed on.

- 3.2 Having stated this, if the CAA were presented with details of a modification (or Flight Manual amendment etc.) which was identified as being identical to one which from prior experience it knew would satisfy an airworthiness requirement, such a modification would have to be considered acceptable. Where this involves a light aircraft type of which there exist or are likely to be numerous operators, the CAA may, for efficiency, issue a CAA Supplement to the Flight Manual or Pilot's Operating Handbook, based on data or information supplied by a manufacturer or an Applicant. As with the situation described in paragraph 2, the CAA can have no justification for requiring further evidence once it has been established that its requirements can be satisfied in a particular way. The onus is, of course, still upon such an applicant to demonstrate that the relevant circumstances are identical.

4 Evidence of Identity

- 4.1 To establish that a component, item of equipment, complete aircraft, or operating condition is identical to one already approved may not be a simple matter. Design criteria, manufacturing processes, quality control, systems safety assessments, flying qualities and performance, etc., may all be involved and have to be considered.
- 4.2 In view of this, the CAA will invariably require applicants who request certification on the basis of identity to provide evidence that this claim is supported by the original applicant (manufacturer, operator, etc.) against whose certification comparison is being made. In the absence of such confirmation, the CAA will normally require substantiating data to be developed and presented to justify certification in its own right.

Leaflet B-180 Experience from Incidents

1 Introduction

- 1.1 From time to time incidents occur, usually in aircraft operations, which in the opinion of the CAA reflect the need for a general awareness of possible hazards resulting from maintenance or design practices and which may have a general application.
- 1.2 Such information was formerly published in CAP 455 as Appendices to Airworthiness Notice No. 12. As part of a steady programme to rationalise CAA technical publications, it is intended to have only one publication for all of CAA's advisory material. CAP 562 has been chosen as the vehicle for this. Therefore the Appendices contained in Airworthiness Notice No. 12 have been transferred into this Leaflet.
- 1.3 The Appendices in this Leaflet are presented in a manner consistent with other aviation publications, which have been sorted, where possible, into Air Transport Association of America Specification 100 (ATA100) chapters. Where an appendix will not align with ATA100 chapter numbers, the CAA has allocated an unused chapter number indicated by an * for the purpose of this Leaflet B-180.
- 1.4 The purpose of this Leaflet is to inform organisations and individuals (such as LAEs) of these incidents and to advise future actions to minimise the probability of recurrence in order to enhance flight safety.
- 1.5 The applicability of information in each Leaflet will usually be self evident from the text. In most cases the applicability is to maintenance activities but some have implications for design organisations.
- 1.6 The CAA wishes these Leaflets to be used as advice on 'good maintenance practices' in the context of Part 145.A.65(c)1.
- 1.7 The ATA 100 chapters used in this Leaflet are shown in the following table.

Chapter No	Description	Appendix No	Appendix Title
1	Operations Information	1-1	Damage to Packages of Dangerous Goods Caused by Inadequate Securing of Hold Floors
		1-2	The Consignment by Air of Aircraft Spares and Consumables which meet the Criteria of 'Dangerous Goods'
		1-3	Foreign Object Damage to Aircraft and Engines
4*	Maintenance Information	4-1	Ambiguous Information
		4-2	The Use and Interpretation of Unfamiliar Units
		4-3	Responsibilities of Engineers who carry out and certify Maintenance on Aircraft

		4-4	CAA Approval and Continued Airworthiness of the L-3 Communications Model F-800 Digital Flight Data Recorder
		4-5	Retention of Aircraft, Engine, Propeller and Component Records
5	Time Limits/ Maintenance Checks	5-1	Aged Components – Permit to Fly Aircraft
		5-2	Planning and Recording of Non-Scheduled Maintenance Tasks
9	Towing and Taxiing	9-1	Ground Handling of Transport Aircraft
		9-2	Aircraft Towing and Limitations
10	Parking, Mooring, Storage and Return to Service	10-1	Control of the use of Pitot Head and Static Vent Blanking Covers
11	Placards	11-1	Aircraft Marking and Placards
12	Servicing	12-1	Fluids used in Aircraft
		12-3	Helicopter Gearbox Oil Level Sightglasses
		12-4	Ice Falls from Aircraft
20	Standard Practices	20-1	Soft Metal Shims
		20-2	Crowded Ball Races
		20-3	Unauthorised Alteration of Parts
		20-4	Maintenance and Re-installation of Pipes and Cable Looms
		20-5	Hazards of Damage Caused by Arc Burns
		20-6	Hydraulic Fluid Contamination
22	Auto Flight	22-1	Auto-Pilots on Light Aircraft
24	Electrical Power	24-1	Electrical Power Supplies - Light Aircraft Care and Maintenance
		24-3	Electrical Cable Failure
		24-4	Thermal Circuit Breakers
		24-5	Battery Terminal Failure - GA Aircraft
		24-6	Lithium Batteries
		24-7	Aircraft Electrical Cable SAE-AS 22759/16, 17, 18, 19 and MIL-W-22759/16, 17, 18 and 19
25	Equipment and Furnishings	25-1	Single Lock Airframe Seat and Furnishing Attachments
		25-2	Stowage and Accessibility of Lifejackets

		25-5	Seat Belts in Light Aircraft - Orientation of Stitched Joints
		25-6	Emergency Escape Provisions - Doors and Escape Slides
26	Fire Protection	26-1	Fire Hazards
27	Flight Controls		
		27-2	Flap Systems on General Aviation Aircraft
		27-3	Control and Use of Rigging Pins
		27-4	Control Cable End Fittings
31	Instruments	31-1	Altimeters in Aircraft
		31-2	Vertical Speed Indicators on Imported Aircraft
32	Landing Gear	32-1	Brake and Anti-Skid Systems
		32-2	Tyre Maintenance and Reliability
33	Lights	33-1	Bonding of Strobe Lights
34	Navigation Equipment	34-1	Maintenance of Radio Navigation Equipment Course and Alarm Signal Current Limits
		34-2	Mode 'S' Transponder ICAO 24-bit Aircraft Addresses
		34-3	ATC Transponders and Traffic Alert and Collision Avoidance Systems (TCAS) Ground Testing
35	Oxygen	35-1	Oxygen Fire Risk
		35-2	Passenger and Crew Oxygen Systems
51	Standard Practices		
		51-2	Primary Structural Fasteners made in H-11 Steel
		51-3	Corrosion Inhibiting (Temporary Protective) Compounds
		51-4	Lock-Bolt Failures
		51-5	Control of Precision Cutting Tools
		51-6	Self-locking Fasteners
		51-7	Foreign Objects and Loose Articles – Danger of Jamming
56	Windows	56-1	Aircraft Windshields and Transparencies
70	Standard Practices - Engines		
		70-3	Effects of Chloride Based Materials on Stainless Steel and Titanium

72	Engine (Turbine/ Turboprop)	72-1	Air intake Filters
76	Engine Controls	76-1	Single Path Control Systems

APPENDIX 1-1 Damage to Packages of Dangerous Goods Caused by Inadequate Securing of Hold Floors

1 Introduction

This appendix supersedes Airworthiness Notice No. 12 Appendix 56 Issue 1 dated 7 November 1997.

2 Background

Dangerous goods are regularly and routinely carried as cargo in aircraft. A comprehensive set of rules produced by ICAO, the 'Technical Instructions for the Safe Transport of Dangerous Goods by Air' ensures that this is a perfectly safe practice. Packaging must meet specific design criteria and be subjected to a stringent test regime before it may be used to contain dangerous goods for air transport. However, a number of incidents have occurred involving damage to metal drums, both in the United Kingdom and world-wide, resulting in leakage of dangerous goods in cargo holds. The damage observed was of a very specific type and occurred to the bases of drums. The vast majority of incidents were experienced after carriage on narrow body aircraft.

3 Airworthiness and Operational Considerations

- 3.1 Certain types of dangerous goods may be consigned in metal drums, the capacity of which can be up to 60 litres when transported on passenger aircraft. The attendant weight of such drums makes it physically impossible for loading staff to lift them in the confined space of the holds of narrow body aircraft. Consequently, drums tend to be dragged to their intended loading position. As part of the investigation into the instances of drum leakage, the floors of 20 cargo holds of narrow body aircraft were inspected. All but one of the floors had securing screws which were protruding to various degrees above the surface of the floor. Some screws had been worn to produce a very sharp edge and loading staff suggested they may also be the cause of injury.
- 3.1.1 Subsequent tests using a simulated hold floor, including screws of the exact type seen during the hold inspection, resulted in drum damage identical to that experienced in incidents. Protrusion of between 0.25mm and 0.5mm was sufficient to cause the damage.
- 3.2 The potential dangers associated with spillage or collection of *any* fluid in aircraft; leakage of dangerous goods may present an even greater risk. The attention of operators and maintenance organisations is drawn to the importance of the correct fitting of cargo hold floors, including the need to ensure (where appropriate) screws are secured such that they do not protrude above the surface of the floor panel. Furthermore, particular attention must be paid to the handling of metal drums during their preparation for transport, the type of aircraft on which they are to be carried and the method required to load that aircraft, so that accidental damage is not caused through dragging or other mishandling of the packages. Repetitive findings of damage should result in a review of the maintenance schedule and operating (loading) procedures for effectiveness.

Appendix 1-2 The Consignment by Air of Aircraft Spares and Consumables which meet the Criteria of 'Dangerous Goods'

1 Introduction

- 1.1 This Appendix highlights the dangers associated with the improper air transport of aircraft components and consumables meeting the criteria of 'Dangerous Goods'.

2 Background

- 2.1 Dangerous Goods are defined as articles or substances which are capable of posing a risk to health, safety, property or the environment when transported by air and which are classified according to the ICAO's Technical Instructions for the Safe Transport of Dangerous Goods by Air. Personnel may be more familiar with the field document produced by IATA, the Dangerous Goods Regulations. These reflect the Technical Instructions and as such are a comprehensive set of rules to ensure the safe transport of dangerous goods by air.
- 2.2 The Air Navigation (Dangerous Goods) Regulations apply the requirements of the Technical Instructions to both international and domestic air transport. A breach of the Regulations is a criminal offence and the penalties issued by courts reflect the potentially very serious consequences.

3 Airworthiness Considerations

- 3.1 Aircraft components are installed in accordance with prescribed airworthiness specifications such that they do not present a hazard to the aircraft or its occupants. However, this safeguard may not apply to such items if they are shipped as cargo or stores without being packed, marked, labelled and declared in accordance with the ICAO Technical Instructions. This was graphically demonstrated by the ValuJet 592 accident in 1996 in which 110 passengers and crew were killed. This accident occurred following an intense in-flight cargo hold fire caused by the improper carriage of chemical oxygen generators as company stores. These generators had previously been safely installed in aircraft passenger service units (PSUs) but had been removed and shipped in a manner such that they presented an extreme danger. As a result of this accident, chemical oxygen generators are now forbidden for carriage on passenger aircraft and may only be carried on a cargo aircraft subject to, amongst other things, very stringent packing requirements which are specified in the Technical Instructions.
- 3.2 Incidents involving chemical oxygen generators and other dangerous goods continue to be reported. Accordingly, it is essential that procedures are established to ensure that dangerous goods can never be offered for air transport when not fully meeting the requirements.

4 Assignment of Responsibilities for the Identification and Consignment of Dangerous Goods by Air

- 4.1 Engineering procedures should detail the dangerous goods responsibilities of all personnel involved with the procurement, receipt, inventory and shipment of dangerous goods, including shipment from line stations that do not have stores facilities.

5 Identification of Dangerous Goods

5.1 Components

- 5.1.1 Dangerous goods can be found in various aircraft components, including the following:

- Chemical oxygen generators on their own or installed within Personal Breathing Equipment (PBE) or Passenger Service Units (PSU)
- Explosives cartridges of engine fire bottles and some passenger seat belts
- Line cutting explosives of helicopter winches
- Signalling flares
- Aircraft batteries
- Lithium batteries found within aircraft lighting, beacons (including personal locator beacons) or electronic devices such as electronic flight bags, personal entertainment devices, credit card readers
- Fire bottles, e.g. from APU, engines, lower cargo compartment and lavatory waste containers
- Fire extinguishers
- Oxygen cylinders
- Escape slides and life rafts
- Fuel Control Units (FCU) and fuel line components with fuel residue (e.g. after removal from aircraft)
- Tyres - when unserviceable and inflated to a pressure ≥ 200 kPa at 20° (2 Bar or 29 PSI)
- Adhesives
- Paint
- Oxidising repair kits
- Radioactive materials - ignition excitors, tritium signs (aisle and emergency exit doors) and depleted uranium counter-balance.

- 5.1.2 Some aircraft manufacturers such as Airbus and Boeing are able to provide lists of those components which are classified as dangerous goods, identified by part number. It is recommended that procedures require dangerous goods be flagged as such when creating new entries for components and consumables on inventory systems.

- 5.1.3 For batteries, datasheets should be obtained in order to establish whether they are dangerous goods. In addition, when shipping lithium metal or ion batteries, evidence

that each cell or battery is of the type proved to meet the requirements of each test of the UN Manual of Tests and Criteria, Part III, subsection 38.3 is also required.

- 5.1.4 The CAA produces a poster entitled 'are your spares dangerous?' aimed at raising awareness of dangerous goods found within aircraft spares and consumables. Free copies are available upon request to dgo@caa.co.uk

5.2 Identifying dangerous goods within consumables

- 5.2.1 The dangerous goods status of consumables should be established by referencing the manufacturer's Safety Data Sheet. REACH (**R**egistration, **E**valuation, **A**uthorisation & restriction of **C**hemicals) is a European Union regulation controlling chemicals in Europe. REACH requires for many substances and mixtures, a Safety Data Sheet (SDS) to be provided either before or at the time of first delivery. Section 14 of the EU format SDS provides basic classification information, i.e. UN Number, Proper Shipping Name, Class/Division and Packing Group.
- 5.2.2 Many consumables (and everyday household items) bear consumer warning labels which indicate whether they are classified as dangerous goods in transport. The Regulation on Classification, Labelling and Packaging of Substances and Mixtures (known as the CLP Regulation) requires suppliers within Europe to label goods in accordance with the Globally Harmonized System of Classification and Labelling of Chemicals (GHS). Products bearing the following GHS labels ARE classified as dangerous goods:



Note: A product bearing the GHS corrosive label (depicted far right above) is NOT classified as dangerous goods if the signal word 'Danger' and hazard statement 'causes serious eye damage' applies.

- 5.2.3 Products bearing the following GHS labels (and none of the above) are NOT classified as dangerous goods:



6 Dangerous Goods Training

- 6.1 It is also a requirement of the Technical Instructions and the Air Navigation (Dangerous Goods) Regulations that all staff with duties associated with the transport of dangerous goods by air successfully complete dangerous goods training and testing commensurate with their responsibilities. Training must be provided or

verified upon the employment of personnel. Recurrent training must be provided within 24 months of previous training in addition to the remainder of the month of completion to ensure knowledge is current. If recurrent training is completed within the final three months of validity of previous training, the period of validity shall extend from the month of completion until 24 months from the expiry month of that previous training.

- 6.2 A test to verify understanding must be undertaken following training and confirmation that the test has been completed satisfactorily is required. The records of training must be retained by the employer for a minimum period of 36 months from the most recent training completion month and must be made available upon request to the employee or the appropriate national authority.
- 6.3 Persons preparing consignments of dangerous goods for transport by air must receive detailed training commensurate with their responsibilities. This training may either be provided by a CAA Approved Dangerous Goods Training Organisation, or may be delivered in-house provided that as a minimum the training meets the requirements of CAP 483: Training in the Safe Transport of Dangerous Goods by Air, and reflects the specific responsibilities of the person receiving the training.
- 6.4 Procurement staff, stores personnel (other than shippers) and line engineers with responsibilities for the identification or shipment of dangerous goods must complete basic dangerous goods training and testing commensurate with their specific responsibilities. Suitable training and testing provided by a competent instructor, through CBT or prescribed self-study books each meet the requirement to provide training at this level.

7 Arrangements for Shipping Dangerous Goods by Air

7.1 General Requirements

- 7.1.1 Consignors (shippers) of dangerous goods have a responsibility under the Regulations and the Technical Instructions to ensure that all applicable requirements are met; these include correctly classifying and identifying dangerous goods, packing them according to a prescribed method, marking and labelling packages and providing a dangerous goods transport document to the air carrier.
- 7.1.2 The air carrier is responsible for conducting a detailed acceptance check prior to carriage. This is required, even if the goods are urgently required for an 'Aircraft on Ground' (AOG) so dangerous goods must always be offered for carriage in accordance with the carrier's requirements, not simply delivered to a departing aircraft. It is imperative that airline engineering personnel who deliver dangerous goods for carriage by air are aware of this.
- 7.1.3 Procedures should explain the organisation's arrangements at stores and line maintenance facilities for consignments of dangerous goods to be prepared for transport by properly qualified personnel, e.g. whether such duties will be performed in-house or by an appointed specialist freight forwarder. Procedures should also

address any potential need for components classified as dangerous goods removed from AOG aircraft (e.g. PSUs, fuel system components with fuel contamination, etc) to be shipped, including the use of a specialist freight forwarder if required.

- 7.1.4 Engineers' toolboxes must not contain aircraft spares or consumables classified as dangerous goods when carried by air in the course of their duties, unless this method of packaging complies with the applicable packing instruction and the dangerous goods have been properly prepared, declared and accepted for transport as cargo or stores in accordance with the Technical Instructions.

7.2 Packaging

- 7.2.1 When a packing instruction requires the use of UN specification packaging, the selected packagings must be used and closed in accordance with the manufacturer's instructions provided on the test certificate and schedule. These documents typically specify whether the packagings were tested to contain solids, liquids or articles (indicating whether the package is suitable for the intended application); detail the number, type and construction of inner packagings and how packages must be closed, e.g. the type and width of tape which must be used. Procedures should specify where package test certificates and schedules for all packagings held are available and that these must be referred to and complied with by packing staff on each occasion that dangerous goods are packed for shipping. The Vehicle Certification Agency (VCA) Dangerous Goods Office has responsibility for the certification of dangerous goods packaging within the UK and a database listing its dangerous goods packaging approvals is available via the VCA website at <http://www.dft.gov.uk/vca/dangerousgoods/dangerous-goods-packaging.asp>
- 7.2.2 The database provides basic information on the approvals, such as the tested contents, but does not provide the manufacturer's detailed instructions for package use and closure; the approval and schedule must be referred to for this information

7.3 Packagings for Chemical Oxygen Generators

- 7.3.1 The air transport packaging requirements for Oxygen generators, chemical (UN3356) are demanding. For example, UN specification packaging is required and the generator(s) must be transported in a package which will meet the following requirements when one generator in the package is actuated:
- 1) other generators in the package will not be actuated;
 - 2) packaging material will not ignite; and
 - 3) the outside surface temperature of the completed package will not exceed 100°C.
- 7.3.2 For chemical oxygen generators the packaging approval certificate or schedule should list the component reference of the generator concerned and certify that the above requirements have been met.

7.4 Classification of Explosives

- 7.4.1 When shipping any explosive to, from or within Europe it must have been assigned a classification by the Competent Authority of a Contracting Party to the European Agreement Concerning the International Carriage of Dangerous Goods by Road (ADR). Within the UK, classifications are issued by the Health and Safety Executive. Explosives must be packed for transport using the precise packagings specified in the classification document for the component concerned (usually identified by its specific packing test certificate number).

8 Compliance Monitoring

- 8.1 The identification and shipment of dangerous goods and associated procedures, training and documentation should be included within the scope of the compliance monitoring programme. Auditors should have suitable training and/or experience of dangerous goods transport requirements to enable them to conduct effect audits.

APPENDIX 1-3 Foreign Object Damage to Aircraft and Engines

1 Introduction

This Appendix supersedes Airworthiness Notice No. 12 Appendix 68, Issue 2, dated 28 September 2005.

2 Background

- 2.1 The CAA continues to receive reports of damage to aircraft and engines caused by foreign objects (FOD). Foreign object damage presents a serious airworthiness threat to any aircraft not to mention the economic impact on the operator. In extreme cases, FOD can lead to an accident and loss of life. FOD damage to airframes and engines can be extremely expensive to rectify and may result in the aircraft being removed from revenue service for significant periods of time. There are numerous reports on record of FOD damage to engines (in particular rotating assemblies), nose and main landing gear assemblies and aircraft structure.
- 2.2 Recent audits of airports, including a 10-month study at one major UK international airport, have revealed that a continuing threat exists from varying amounts of FOD present on aircraft maintenance areas and airport-manoeuving areas, including stands, aircraft taxiways and runways. The study showed the aircraft themselves as the main cause of FOD on the runway and this poses the highest immediate risk. Here, parts of aircraft become detached or tools and equipment, inadvertently left in the aircraft fall out during take off or landing. The largest item found on a runway was a wheel chock but metal panels and honeycomb structure were also amongst the larger items. The FOD found on taxiways and stands came mainly from airport vehicles and the equipment they tow such as baggage trolleys, steps, cargo equipment etc. The size and shape of some of this FOD makes it likely to cause tyre damage and subsequent tyre burst. The cleaning of aircraft cabins and the transfer of waste from cabin to airside rubbish containers is also seen to be a common source of FOD in the stand areas. Other typical FOD consists of such items as oil cans, spanners, pliers, engineers torches, suitcase items (both internal and external), mobile radios, aircraft catering equipment, cutlery, landing gear ground lock pins, thrust reverser lock-out pins and broken parts of ground servicing equipment/ vehicles.
- 2.3 Smaller items could be ingested by an engine. In many cases, FOD damage to engine rotating assemblies has led to vibration leading to air turn-backs, diversions and subsequent engine replacement. Boroscope inspections of engines following reports of engine surging very often reveal internal damage to the engine – such damage can of course be very expensive to repair. Typically, damage to the aircraft can range from damage to horizontal stabilizer leading edges to pressure hull penetration by objects thrown up from the runway, to varying degrees of damage to landing gear assemblies and main-planes. It is not unusual for tyre treads (nose and main) to detach as a result of FOD damage during take-off and landing causing damage to the fuselage, wings, trailing edge flaps, lift dumpers, engine intakes and compressors. Tyre tread detachment often occurs within several takeoffs / landings of an earlier penetration of the tread by an item of FOD. It is known that in some cases aircraft have been lost due to FOD damage to tyre assemblies and has lead to significant loss of life.

3 Operator, Maintenance and Ground Handling Organisation Recommended Best Practice

- 3.1 Aircraft operators should not allow their aircraft to be positioned onto arrival/ departure stands unless satisfied that the stand is clean and free from FOD. Operators should consider the implementation of procedures whereby its staff or contracted ground handling personnel check parking stand cleanliness standards prior to aircraft arrival on stand and again following its departure from stand prior to being occupied by the next aircraft.
- 3.2 Aircraft operators should ensure that the topic of FOD is placed as a standing agenda item on all airport users committee meetings that it attends and internal airline safety meetings as necessary in order that the topic is adequately covered and remains visible at all times. It is suggested that operators may wish to nominate an individual with responsibility for the implementation of the airline's policy in this area.
- 3.3 Aircraft operators and maintenance organisations should implement procedures that would preclude tools, inspection equipment or other service items being left in the aircraft installations following routine or unscheduled maintenance (e.g. undercarriage bays, engine intakes) and/or at the airport areas where the work took place.
- 3.4 Airport authorities and maintenance organisations should ensure that adequate cleaning/sweeping programmes are in place for those aircraft ramp and maintenance areas under their control. Airport authorities and maintenance organisations should provide sufficient numbers of strategically positioned FOD bins that should be readily visible and placarded as to their use.
- 3.5 Aircraft operators, maintenance and ground handling organisations should include FOD in their induction and continuation training programmes. For example, the practice of putting chocks and other loose equipment on aircraft tugs in positions from where it can fall unnoticed should be discouraged.
- 3.6 Aircraft operators and maintenance organisations should consider the inclusion of FOD into their ramp area audits ensuring that where problems exist that the persons responsible are notified without delay. Where FOD is a persistent problem and no effort is made to rectify the problem, consideration should be given to reporting matters to the CAA's Aerodrome Standards Department.
- 3.7 Aircraft operators should ensure that contracted aircraft cleaning and ground handling organisations are made aware of its policies regarding the prevention of FOD during cabin cleaning and ground handling operations. This should include the condition of vehicles and the quality of repairs made to them.
- 3.8 Some aircraft types are permitted to back off the stand using high power reverse thrust settings. Operators of such types are reminded that these operations can be susceptible to FOD. Operators carrying out such operations should ensure that they are only carried out in accordance with manufacturer's recommendations and from clean, contamination free ramp areas.

REMEMBER THE ONLY ACCEPTABLE FOD IS NO FOD!

APPENDIX 4–1 Ambiguous Information

1 Introduction

This Appendix supersedes Airworthiness Notice No. 12 Appendix No. 25 Issue 1 dated 22 January 1979 which was originally issued as a result of ambiguities in maintenance documents.

2 Background

- 2.1 During an investigation into an accident, it became apparent that some information contained in the maintenance documents for the aircraft was in fact ambiguous and had led to confusion in the minds of the staff concerned.
- 2.2 Whilst care is taken by all concerned, it is not always possible to avoid error or ambiguity, and in consequence, instructions may occasionally be found to be inaccurate or not clear as to their meaning.

3 Airworthiness Considerations

EASA Part 145.45 (c) and AMC 145.A.45 (c) require that a Part 145 approved organisation has procedures in their Maintenance Organisation Exposition detailing how any maintenance data errors and ambiguities should be reported to the author of the data. A record of these communications should be kept until the error or ambiguity has been addressed by the author of such data. Any person or organisation not subject to the Part-145 regulation who identifies ambiguities or errors in approved documents of any kind (Maintenance Schedules, Flight Manuals, etc.) should inform the organisation responsible for the publication of the source data so that any uncertainties which could affect airworthiness can be corrected.

APPENDIX 4–2 The Use and Interpretation of Unfamiliar Units

1 Introduction

This Appendix supersedes Airworthiness Notice No. 12 Appendix No. 28 Issue 1 dated 2 October 1981.

2 Background

CAA publications have for some years included units from the SI system alongside the previous Imperial Units.

3 Airworthiness Considerations

- 3.1 The use of SI Units (Système International) within the United Kingdom is dealt with in a publication 'Changing to the Metric System' issued by the National Physical Laboratory and obtainable from The Stationery Office, and in BSI 5775, obtainable from the British Standards Institute.

- 3.2 The names of the various units, the symbols used for them, and the methods to be used for presentation of those symbols in technical documents, are dealt with in both documents.
- 3.3 The correct understanding of technical information and instructions can depend upon the symbols used and their method of presentation. Hence, it is important that where safety may depend on the correct interpretation of symbols, product support departments and others involved in the dissemination of safety documents should consider whether any doubt could exist. Where this is the case, potentially ambiguous notation should be explained and illustrated by examples, where appropriate.
- 3.4 Where the users of such documents are in any doubt, they should make a careful check using reference documents such as those mentioned in paragraph 2.
- 3.5 In one case, a degree of uncertainty evidently arose when an area was expressed using the symbol 'mm²' to express the concept of a square millimetre. This usage is similar to that, in Imperial Units, of 'in²' to represent square inches (or 'sq in').
- 3.6 Figure 1 illustrates the unit of area of one square inch, or 1 in² (cross-hatched). An area of two square inches is shown, occupying twice the area. A two inch square, i.e. a square of sides 2 inches, clearly occupies four times the area or 4 in².

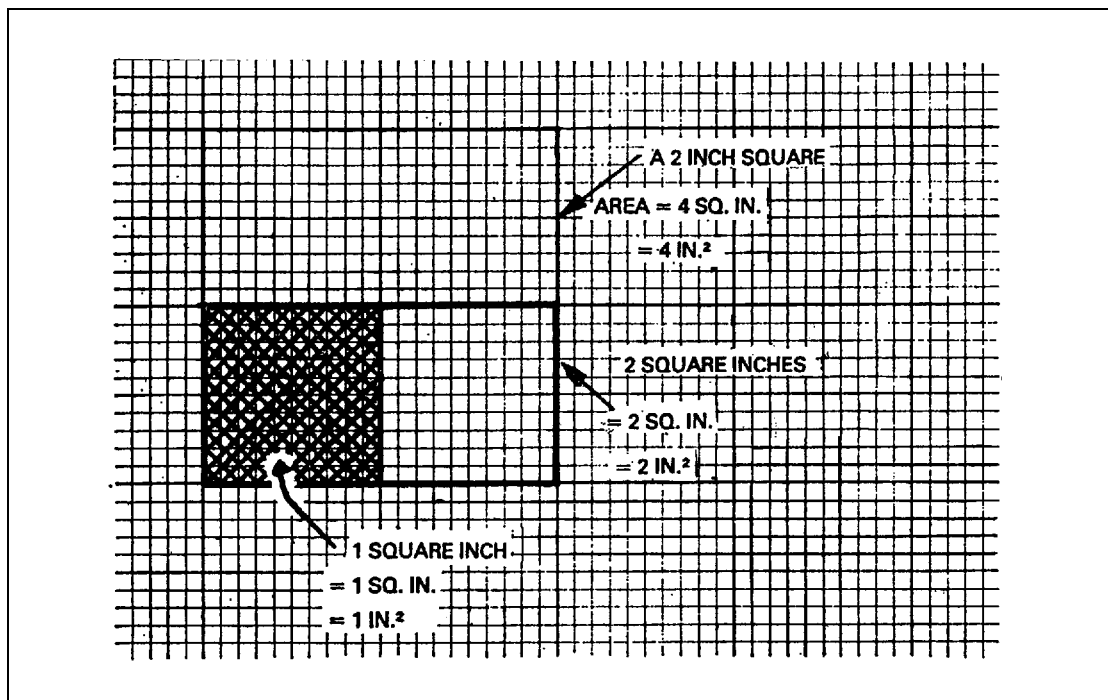

Figure 1

- 3.7 Figure 2 similarly illustrates the unit of area of one square millimetre, or 1 mm^2 , and as an example, an area of 50 square millimetres (i.e. 50 mm^2 , in that case a rectangle 5 mm by 10 mm). Once again this is quite different from the area of a 50 mm square, which is 50 times greater.

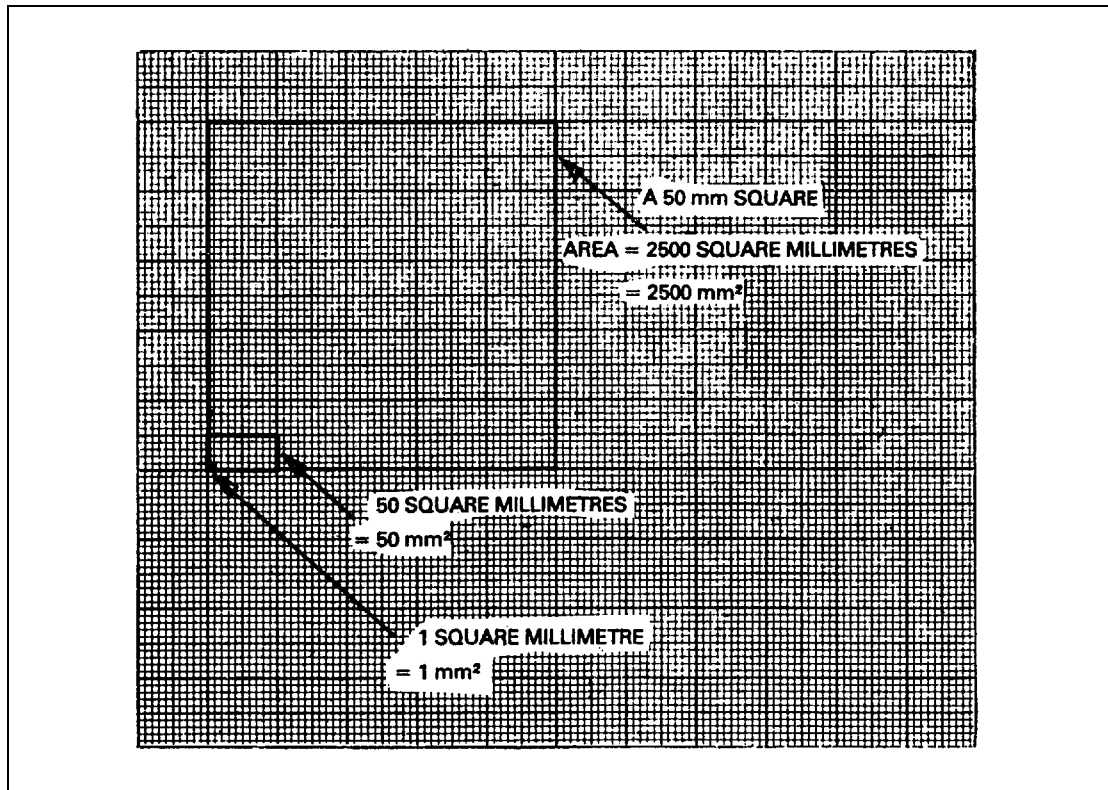

Figure 2

- 3.8 This Appendix is issued for information and action by all concerned. Reference should also be made to CAAIP Leaflet B-180, Appendix 4-1 Ambiguous Information.

APPENDIX 4-3 Responsibilities of Engineers who carry out and Certify Maintenance on Aircraft

1 Introduction

This Appendix supersedes Airworthiness Notice No. 12 Appendix 52 Issue 1 dated 19 July 1996 which was issued as a result of an enquiry into a serious incident which occurred to an aircraft on the first flight following maintenance being carried out.

2 Background

The CAA wishes to remind Licensed Aircraft Maintenance Engineers and Authorised Certifying Staff employed by Part-145 Approved Maintenance Organisations of their responsibilities when issuing Certificates of Release to Service after maintenance.

3 Certification Responsibilities

CAP 562 Leaflet H-20 specifies the certification responsibilities for Type Rated Licensed Aircraft Maintenance Engineers in relation to Articles 25, 26, 28, 29, 30 and 31 of the Air Navigation Order 2009 (as amended). Paragraph 1.7 includes the following information relative to the certification of maintenance:

'A Certificate of Release to Service shall only be issued for a particular overhaul, repair, replacement, modification, mandatory inspection or scheduled maintenance inspection when the signatory is (signatories are) satisfied that the work has been properly carried out and accurately recorded, having due regard to the use of:

- a) up-to-date instructions including manuals, drawings, specifications, CAA mandatory modifications/inspections and company procedures,
- b) recommended tooling and test equipment which is currently calibrated where applicable, and
- c) a working environment appropriate to the work being carried out.'

4 Part-145 requirements apply to Authorised Certifying Staff employed by Part-145 Approved Maintenance Organisations who should be fully conversant with their content, particularly the following extracts from the requirements which are pertinent when carrying out and certifying maintenance:

4.1 Part 145.A.40 Equipment, tools and material

(See AMC 145.A.40)

- a) The Part-145 approved maintenance organisation must have the necessary equipment, tools and material to perform the approved scope of work.

NOTE: The associated AMC 145.A.40 (a) states 'Once the applicant for approval has determined the intended scope of approval for consideration by the competent authority, it will be necessary to show that all tools and equipment as specified in the maintenance data can be made available when needed. All such tools and equipment that require to be controlled in terms of servicing or calibration by virtue of being necessary to measure specified dimensions and torque figures etc, should be clearly identified and listed in a control register including any personal tools and equipment that the organisation agrees can be used.'

4.2 Part 145.A.45 Airworthiness data

(See AMC 145.A.45)

- a) The Part-145 approved maintenance organisation must be in receipt of all necessary airworthiness data from the CAA, the aircraft/aircraft component design organisation and any other approved design organisation, as appropriate to support the work performed.

NOTE: AMC 145.A.30(e) Personnel Requirements. Paragraph 3 states 'To assist in the assessment of competence, job descriptions are recommended for each job role in the organisation. Basically, the assessment should establish that -

- d. Supervisors are able to ensure that all required maintenance tasks are carried out and where not completed or where it is evident that a particular maintenance task cannot be carried out to the maintenance data then such problems will be reported to the 145.A.30(c) person for appropriate action. In addition, for those supervisors who also carry out maintenance tasks, that they understand such tasks should not be undertaken when incompatible with their management responsibilities.'

4.3 Part 145.A.50 Certification of maintenance

(See AMC 145.A.50)

- a) A certificate of release to service must be issued by appropriately authorised staff on behalf of the Part-145 approved maintenance organisation when satisfied that all required maintenance has been properly carried out by the Part-145 approved maintenance organisation in accordance with the procedures specified in the Part 145.A.70 maintenance organisation exposition

4.4 Part 145.A.65 Safety and quality policy, Maintenance procedures and quality system (See AMC 145.A.65)

- a) The Part-145 approved maintenance organisation must establish procedures acceptable to the CAA to ensure good maintenance practices and compliance with all relevant requirements in this Part-145 such that aircraft and aircraft components may be released to service in accordance with Part 145.A.50. Part 145.A.65 Paragraph (b)2 states 'The maintenance procedures established or to be established by the organisation under this paragraph shall cover all aspects of carrying out the maintenance activity, including the provision and control of specialised services and lay down the standards to which the organisation intends to work.'

5 The CAA consider that:

- a) the responsibilities defined in both CAP 562 Leaflet H-20 and Part-145 are fundamentally equivalent and require work to be carried out to specified maintenance instructions using recommended tooling and, when working in approved maintenance organisations, in accordance with established procedures.
- b) it is important to adhere to publications which provide instructions for continued airworthiness together with company procedures which lay down the standards for work carried out by Licensed Aircraft Maintenance Engineers, Authorised Certifying Staff and Approved Maintenance Organisations. The privileges of Licensed Aircraft Maintenance Engineers and Authorised Certifying Staff do not include authority to deviate from such instructions or procedures.

APPENDIX 4-4 CAA Approval and Continued Airworthiness of the L-3 Communications Model F-800 Digital Flight Data Recorder

1 The Federal Aviation Administration (FAA) has cancelled the Technical Standard Order (TSO) Authorisation for the L-3 Communications (Formerly known as LORAL Data Systems and Fairchild Aviation Recorders, Sarasota, Florida 34232 USA) Digital Flight Data Recorder Model F-800. This followed reports of several performance problems related to this type of magnetic tape recorder. Some of these problems have caused difficulties for air accident investigators when replays are conducted. The CAA has conducted its own review of the service experience of the Model F-800 and has drawn similar conclusions to those of the FAA.

2 The CAA has declared the BCAR Equipment Approval Number AR 515 obsolescent. This means that the L-3 Communications Model F-800 Digital Flight Data Recorder may not be newly installed on any UK registered aircraft for the purposes of compliance with any mandatory carriage requirement. (Mandatory carriage requirements are specified in the UK Air Navigation Order 2009 (as amended), EU-OPS or the Joint Aviation Requirements JAR-OPS 3, as appropriate.) However, where already installed in a UK registered aircraft, the Model F-800 may continue to be used, serviced and repaired, as necessary, until such time as the aircraft operator

chooses to replace it with another model of flight data recorder. In such cases the Model F-800 installation will still be accepted as being compliant with the mandatory carriage requirements.

- 3** Following the FAA TSO approval cancellation, L-3 Communications no longer manufacture the Model F-800 but they are still providing continued airworthiness support and are continuing to manufacture spares. However, in their Field Service Bulletin No. F800 DFR FSB033, dated 1 April 2000, L-3 Communications announced that the magnetic tape supply used to manufacture the F800 DFR reel and tape assemblies is being depleted. There is a finite and very limited supply of the DFR tape.
- 4** The CAA recommends that aircraft operators and maintenance organisations take these, and any other relevant obsolescence issues into account when reviewing their flight recorder maintenance schedules. Maintainers should ensure that approved replacement parts are acquired to meet future demand.
- 5** In addition, it should be noted that solid state Flight Data Recorder (FDR) technology meeting the standards listed below has become widely available. One of the advantages of this technology is that solid state equipment can be designed to be operated under an on-condition maintenance regime.
 - EUROCAE ED55
 - EUROCAE ED112

APPENDIX 4-5 Retention of Records – Post Incident and Accident Investigations

1 Introduction

This Appendix supersedes Airworthiness Notice No. 12 Appendix 61, Issue 4, dated 29 September 2006.

- 2** During a number of recent accident investigations, the retention of aircraft/engine records was found to be inadequate and incomplete. Considerable difficulty was experienced during these investigations in tracing the full details of the maintenance and repair action taken during the most recent history of the aircraft.
- 3** Aircraft operators, owners and maintenance organisations are reminded of their responsibility to retain adequate, complete and detailed maintenance, repair and modification records as specified in the following paragraphs for the periods listed according to the relevant requirements.
- 4** The requirements for retention of aircraft continuing airworthiness records (necessary for demonstrating the adequacy of continuing airworthiness arrangements) for EASA aircraft operated for both Commercial Air Transport and Non-Commercial Air Transport are identified in EASA Part-M, M.A.305 and M.A.306.
- 5** For non-EASA aircraft, it is the responsibility of the operator to retain the records for the period specified in the Air Navigation Order 2009 (as amended) (currently two years after the aircraft has been destroyed or has been permanently withdrawn from use).

6 EASA Part-145 approved maintenance organisations need to retain a copy of all detailed maintenance records for two years from the date the aircraft or component was released from the Part-145 organisation (Part-145.A.55). This assumes, however, that the Part-145 organisation has provided the operator with copies of all of the relevant documentation for their records (such as work packs and work sheets etc.). Where reference to a work pack is made in a Certificate for Release to Service, this information then forms a part of the permanent records of that aircraft. If the Part-145 organisation is contracted to keep records on behalf of the Operator then the retention period will be two years after the aircraft has been destroyed or has been permanently withdrawn from use as required by EASA Part-M.A. 305 and M.A. 306.

7 The requirements for retention of records for all other aircraft registered in the United Kingdom are defined in the Air Navigation Order 2009 (as amended). Article 34 requires the Operator of the aircraft to keep Aircraft, Engine and Propeller Log Books, and ANO Article 27 requires a Technical Log where applicable. The Log Books must include particulars as specified in ANO Schedule 6, for example:

- Particulars of all maintenance work carried out on the aircraft or its equipment; and
- Particulars of any overhauls, repairs, replacements and modifications relating to the aircraft or its equipment.

It should be noted that for some aircraft types, where there are components that have assigned overhaul, service life or ultimate life limits the use of individual log cards for the components are often used. These form part of an aircraft's records. The retention period is the same as that specified in the Air Navigation Order 2009 (as amended) or Part M as appropriate unless the cards have been returned with the component to an overhaul facility.

Also note that any document, such as a work pack, which is incorporated by a cross-reference entered in a log book, shall be part of the log book and it is the duty of the Operator to retain the above records. Every log book shall be preserved by the Operator of the aircraft until two years after the aircraft has been destroyed or has been permanently withdrawn from use.

8 For Part-M, Subpart F approved Maintenance Organisations (associated with EASA aircraft of 5700 kg and below, and single-engine helicopters) the records retention period is currently three years from the date of release of the aircraft/components.

Aircraft, Engine, Propeller and Component Records Retention: Summary of Requirements

Applicable Entity	Requirement Reference	Minimum Records Retention Period
Part-145 Approved Maintenance Organisation	Part-145.55 All details of maintenance work necessary for issuance of certificate of release to service	At least 2 years from aircraft or component release date. If Part-145 Approved Maintenance Organisation is contracted to retain records by Operator, then requirements for Part-M.A.305 and M.A 306 apply, i.e. at least 2 years after the aircraft or component has been permanently withdrawn from service.
Part-M, Subpart F Maintenance Organisation for EASA aircraft < or = 5700 kg, and single-engine helicopters.	Part-M, M.A.614 Records necessary to prove all requirements have been met for issuance of certificate of release to service.	At least 3 years from aircraft or aircraft/component release dates.
Owner/Operator of EASA Aircraft	Part-M, M.A.305 Continuing Airworthiness Records	At least 2 years after the aircraft or component has been permanently withdrawn from service.
	Part-M, M.A.306 Technical Log (Where applicable)	At least 3 years after the date of last entry
Operator of Non-EASA aircraft (Annex II aircraft)	ANO Article 34 Log Books (Aircraft, engine and propeller) including details of all maintenance, overhauls, repairs, replacements and modifications carried out.	At least 2 years after the aircraft or component has been permanently withdrawn from service.
	ANO Article 27 Technical Log (Where applicable)	At least 2 years after the aircraft or component has been permanently withdrawn from service.

APPENDIX 5-1 Aged Components – Permit To Fly Aircraft

1 Introduction

This Appendix supersedes Airworthiness Notice No. 12 Appendix No. 34 Issue 2 dated 10 December 1986 which was issued following the investigation involving two fatal accidents.

2 Background

A split diaphragm in the fuel pump of a Hercules engine and a corroded capsule of a Gipsy Queen engine resulted in over-rich operation, both of which led to fatal accidents. Power loss in another Hercules engine was probably caused by failure of the insulation in a magneto. In each case extended calendar time between overhauls and low utilisation may have been factors contributing to the deterioration.

3 Airworthiness Considerations

These are just three examples of malfunctions associated with the deterioration of aged components in aircraft which are not maintained to an approved Maintenance Schedule.

- 3.1 It is recommended, therefore, that components including materials where deterioration due to age may occur, be inspected periodically. If signs of ageing, hardening, or deterioration of rubber components, insulation materials, or corrosion of metallic components are found, such components should be assessed and renewed as necessary.
- 3.2 Original servicing schedules and procedures should be used wherever available with due regard to the low utilisation of the aircraft. Operators are advised to consider additional periodic inspections for all components and equipment which may be affected by calendar time deterioration.

APPENDIX 5-2 Planning and Recording of non-scheduled Maintenance Tasks

1 Introduction

This Appendix supersedes Airworthiness Notice No. 12 Appendix No. 53 Issue 2 dated 30 September 1996 which was issued as a result of an enquiry into a serious incident where incorrect and incomplete documentation was cited as a contributory factor.

2 Background

The CAA wishes to remind all Operators, Certifying Engineers and Part-145 Approved Maintenance Organisations of the need to prepare complete documentation prior to the work being accomplished which clearly and accurately defines the non-scheduled maintenance task(s) to be undertaken.

3 Airworthiness Considerations

Non-scheduled maintenance tasks can arise from scheduled maintenance inspections or from defects recorded on operational aircraft. Non-scheduled maintenance tasks require a certificate of release to service be issued when all maintenance relating to the task(s) has been completed.

- 4 Part 145.A.50(a), Certification of Maintenance, specifies 'A certificate of release to service shall be issued by appropriately authorised staff on behalf of the organisation when it has been verified that all maintenance ordered has been properly carried out by the organisation in accordance with the procedures specified in 145.A.70 ...' It therefore follows that the documents recording a non-scheduled maintenance task must contain sufficient detail to enable the Certifying Engineer to determine that it has been properly carried out by the organisation to enable him to issue a certificate of release to service.
- 5 Maintenance tasks on aircraft vary in complexity and task cards raised for scheduled maintenance reflect the level of complexity of the specific task. Control of these complex tasks by maintenance personnel at shop floor level is normally simplified by breaking each task down into a number of discrete steps with the provision for appropriately authorised staff to sign/stamp when each step is completed. It is equally important that non-scheduled maintenance tasks are similarly broken down into steps to provide a detailed record of maintenance which is to be carried out and certified on completion of each step or group of steps as they occur. Engineers are reminded of the need for a full and comprehensive hand-over of work outstanding at shift changes.
NOTE: The CAA endorses the use of stage sheets which is good maintenance practice as it enables personnel to record work to be carried out and provide a record of the accomplishment of that work. Human factors studies in engineering repeatedly show that the use of properly prepared stage sheets when carrying out tasks considerably reduces the opportunity for maintenance errors occurring.

APPENDIX 9–1 Ground Handling of Transport Aircraft

1 Introduction

This Appendix supersedes Airworthiness Notice No. 12 Appendix No. 18 Issue 1 dated 25 March 1977 which was originally issued to alert operators to the possibility of a nose undercarriage failure in older types of aircraft during towing or push-back.

2 Background

There have been a number of occurrences involving nose undercarriage failure in the older types of transport aircraft. These failures can be attributed, at least in part, to loads induced during towing or push-back. Such loads have, in a number of cases, resulted in the initiation of fatigue cracking, leading to subsequent failure under operational loads.

3 Operating Considerations

- 3.1 Aircraft manufacturers specify suitable ground handling equipment, compatible with the aircraft type, designed to avoid overloading, e.g. employing shear pins, which fail at predetermined loads. However, it is possible to induce overloading by rapid acceleration or braking, especially when employing large, powerful tractors to move the smaller types of aircraft. Furthermore, certain manoeuvres now commonly employed, such as 'push-back' were not anticipated in the design of some older aircraft.

- 3.2 Operators, especially those of the older types of aircraft, should ensure that the correct ground handling equipment is always employed, that it is regularly and adequately maintained, and that particular care is taken when using large powerful tractors. Operators should also check with the manufacturer that their ground handling procedures are compatible with the aircraft design.

APPENDIX 9-2 Aircraft Towing and Limitations

1 Introduction

- 1.1 This Appendix supersedes Airworthiness Notice No. 12, Appendix 70, Issue 1, dated 29 March 2006.
- 2** The CAA has been made aware of an incident in which an aircraft sustained structural damage to the nose landing gear to fuselage mounting structure. It is believed that a causal factor in this incident was that ground movement of the aircraft had been undertaken using a hydraulically powered "towbarless" tug and not ensuring that this was accomplished in accordance with the appropriate aircraft manufacturers' instructions.
- 3** Aircraft manufacturers are required, in accordance with type Certification Specifications, to publish Servicing Information. This servicing information must contain, amongst other things, equipment required for servicing and towing instructions and limitations.
- 4** Operators/owners and their maintenance and ground service providers are obliged to comply with all the applicable aircraft manufacturers' instructions in order to ensure the continued airworthiness of their aircraft.
- 5** By publication of this Appendix to Leaflet B-180 the CAA would like to remind all operators/owners that when their aircraft is towed by either themselves or a third party they take the necessary steps to make sure the above obligations and practices are adhered to.

APPENDIX 10-1 Control of the Use of Pitot Head and Static Vent Blanking Covers

- 1** A serious incident involving a large commercial air transport aircraft occurred due to the loss of half the primary reference flight instruments readings during take-off. The reason for the loss was that pitot head blanking covers had not been removed before flight.
- 2** The aircraft had been subjected to an overnight stop during which time all four of the pitot head blanking covers were installed.
- 3** The engineering and flight crew pre-departure check resulted in two of the four pitot head covers being removed. The remaining two were missed, and not removed.
- 4** The pre-departure check was carried out at night and in rain, thus weather and darkness contributed to the incident.

- 5** Good maintenance practices dictate that the installation of blanks or covers requires a clear, unambiguous entry in the Technical Log that the aircraft is no longer airworthy as a result of that installation. This practice would assist line maintenance personnel in ensuring the removal of such items before aircraft acceptance by the flight crew.
- 6** Hence procedures should be instituted by operators and maintenance organisations to control the installation and removal of blanking covers for pitot and static probes.
- 6.1 Open entries should be made, at the time of installation of such blanking cover(s), in the Technical Log, identifying which blanking cover(s) have been installed.
- 6.2 Upon removal of the blanking cover(s) the open entry in the Technical Log should be appropriately annotated and certified.
- 6.3 Emphasising the use of 'temporary' blanking covers, such as masking tape on operational aircraft is not acceptable as it can also result in the type of incident described herein.
- 7** The reliance of warning or attention getting 'flags' attached to blanks or covers is not, in itself, sufficient to insure their identification and removal before flight. This is especially true when completing aircraft pre-departure checks in darkness or adverse weather conditions.
- NOTE:** Operators should consider application of similar practises in respect of other commonly used blanking or locking devices such as landing gear locking pins, intake blanks, external control locks etc.

APPENDIX 11–1 Aircraft Markings and Placards

1 Introduction

This Appendix supersedes Airworthiness Notice No. 12 Appendix No. 45 Issue 1 dated 12 November 1990 which was originally issued to highlight the importance of the legibility and position of markings and placards.

2 Background

Resulting from an enquiry into an accident, the CAA wishes to draw attention to the importance of the correct positioning and legibility of aircraft markings and placards, especially those relating to emergency situations.

3 Maintenance Considerations

- 3.1 Operators and maintenance organisations are reminded that all placards, markings, operating instructions, especially those which pertain to emergency equipment and exits, should be inspected periodically to ensure legibility, complement and location.
- 3.2 The Light Aircraft Maintenance Schedule (LAMS) requires the inspection of placards in Section 7 at Check A, 50 hour, 150 hour and Annual check periods. Where other maintenance schedules do not refer to this subject, action should be taken to revise the schedule as appropriate.

APPENDIX 12–1 Fluids Used in Aircraft

1 Introduction

This Appendix supersedes Airworthiness Notice No. 12 Appendix No. 5 Issue 2 dated 1 April 1985 which was originally issued to warn of the possibility of accidents occurring as a result of incorrect fluids being used.

2 Background

Aircraft are replenished with many fluids during their operation. Accidents and incidents continue to draw attention to the need to avoid the use of incorrect fluids.

3 Airworthiness Considerations

3.1 In addition to the obvious risks associated with damage to systems and failure to function if they are filled with the incorrect fluids, there is a risk that the damage may not become apparent until the aircraft is in flight with possible catastrophic results. Use of incorrect fluids may result from:

- a) Incorrectly establishing the fluid required.
- b) Incorrect identification of the fluid available.

3.2 Identifying fluids

3.2.1 To avoid incorrectly establishing the fluid required, the following should be observed:

- a) Filling points are required to be clearly marked to indicate the fluid to be used and these markings should be maintained in a legible condition.
- b) Where it is critical that the fluid to be used is to a particular specification(s), the marking may either indicate the specification(s) or provide sufficient information to permit servicing staff to determine which specification is applicable. Where neither is indicated, operators should ensure that the servicing staff, whether their own or an agent's, follow a procedure that will ensure that the required specification is correctly established.

3.2.2 To avoid incorrect identification of the fluid available, the following should be observed:

- a) Containers and dispensing apparatus should be clearly marked with the identity of the fluid.
- b) If a 'used' container has to be re-used to contain a fluid other than that corresponding to the original identification, then the identification should be removed or permanently obscured and the identification of the new fluid should be clearly marked on the container.
- c) Fluids should only be obtained from sources whose integrity in respect of the contents of a container is beyond doubt.

3.3 Additional hazards apply when servicing fluids are carried on board aircraft and used to replenish systems when transiting overseas stations. Where foreign handling agents are used, language problems may compound potential problems. Operators should ensure that:

- a) Ideally all fluids are in sealed manufacturer's cans.

- b) Purpose-designed stowages are provided for each fluid type, arranged where possible, to give physical separation between different types.
- c) The stowages are clearly identified as to the contents and that these markings correspond to those on the aircraft filler points.
- d) Procedures on use and replacement are contained in an appropriate Company manual.
- e) Scheduled checks are made to check the identity and stowage of on-board fluids.

APPENDIX 12-3 Helicopter Gear Boxes Oil Level Sightglasses

1 Introduction

This Appendix supersedes Airworthiness Notice No. 12 Appendix No. 43 Issue 1 dated 16 March 1990 which was originally issued following incidents caused by the misreading of oil levels in gearboxes.

2 Background

Several incidents and an accident have occurred after stained oil level sightglasses gave the impression that transmission gearboxes were full, when they were in fact empty. This problem is particularly prevalent when synthetic oil is used.

3 Maintenance Considerations

Operators are reminded that sightglasses should be closely inspected for staining, regularly, and if readability is impaired they should be cleaned.

APPENDIX 12-4 Ice Falls From Aircraft

1 Introduction

This Appendix supersedes Airworthiness Notice No. 12 Appendix 66, Issue 1, dated 23 October 2003 which was issued to highlight the problems which arose from leaking aircraft potable water and toilet systems.

2 Background

- 2.1 In recent years, the CAA has received numerous reports regarding damage to property caused by blue or clear ice falling from aircraft. During the six year period 1997 – 2002, over 200 ice fall reports within the UK were received by the CAA and whilst in the majority of cases it was not possible to identify the offending aircraft it is known that the ice in most of these cases emanated from toilet system servicing points on the aircraft.
- 2.2 On several occasions, where an accurate incident time and location have been provided, ATC radar replays have been able to identify a specific aircraft responsible for the ice fall and follow up investigations have been able to identify an aircraft defect responsible for the ice build-up. Reports received by the CAA show that ice falls from

aircraft occur throughout the year, mainly during descent and in the majority of cases affect properties located under approach paths into the UK's major airports. On those days when higher ambient temperatures exist at lower levels the ice may well melt, reaching the ground as slush or fluid.

- 2.3 The majority of ice accumulations recovered following such incidents are reported as being blue or clear in colour – the blue ice emanating from leaking toilet system servicing points, whereas the clear ice in the majority of cases is believed to come from leaking water system servicing or overflow points. In one incident where significant damage was caused to the roof of a house it was found that the responsible aircraft's water tank overflow valve was stuck open.
- 2.4 Damage to property has ranged from significant damage to house roofs, conservatories, greenhouses, garages and other buildings to cracked car windscreens. Reported sizes of ice range from "pellet" or "melon" size up to the size of a "bag of cement". Whilst there are reports of people on the ground having been struck by falling ice and suffering minor injury, to date there have been no known fatalities.
- 2.5 Quite apart from the potential for falling ice to damage property and cause a hazard to people, ice detaching from an aircraft can present a serious airworthiness threat. There are several cases on record of extensive damage being caused to mainplanes, stabilizers and engines by ice detaching from leaking toilet system servicing points.
- 2.6 Several aircraft have over the years suffered engine detachment during flight due to being struck by ice accumulating at leaking toilet system servicing points. In one case, a large commercial air transport aircraft had a long history of the forward toilet not flushing due to the toilet system repeatedly losing its fluid charge. Eventually, the No. 3 engine detached during cruise at 35,000 ft after being hit by a large piece of ice that became detached from the forward toilet system servicing panel. Damage to engine intakes and compressor sections is not uncommon.
- 2.7 Toilet system fluid readily promotes corrosion and if allowed to leak past toilet system servicing panel sealing arrangements can be forced by the airflow into difficult to access structures (e.g. lap joints) and may well eventually result in the need for expensive repairs to pressure hull boundary structures.
- 2.8 Aircraft operators should be aware that during ramp audits of aircraft by the CAA and indeed by overseas regulatory authorities, any evidence of leakage/staining at toilet and water system servicing points may well result in the aircraft being delayed whilst investigations are carried out. Cases are on record where aircraft with no leaks but with previous staining not removed have been delayed for investigation during such audits.
- 2.9 It should be noted that what might appear to be a small seep/leak on the ground past toilet system servicing point seals will be significantly greater when the aircraft is pressurised.

REMEMBER

THE ONLY ACCEPTABLE LEAK IS NO LEAK!!

3 Operator, Maintenance and Ground Handling Organisation Responsibilities

- 3.1 Whilst toilet and water system details vary between aircraft types, the operating concepts and philosophies are of course similar and operators, maintenance and ground handling organisations should bear the following points in mind.

- Operators must ensure that personnel employed by contracted ground handling companies who provide toilet and water system servicing to the aircraft are fully aware of the reasons for and potential hazards associated with blue/clear ice. Ground handling personnel should be provided with instruction in Aircraft Maintenance Manual procedures for toilet and water system servicing. Continuation training programmes should ensure that these aspects are revisited as and when required. Ground handling personnel should be advised of the need to report leakage, damage or any servicing difficulties to maintenance personnel for corrective action.
- Reports of inoperative toilet flush and water systems especially where the fluid charge is being lost should be investigated and rectified without delay.
- Galley and toilet sinks that refuse to drain in flight are often an indication of a failed drain mast heater and therefore another possible source of ice accumulation.
- Operators should ensure that the aircraft maintenance programme contains all the manufacturer's recommendations for the maintenance of such systems.
- Operator and maintenance organisation quality departments should include inspection of toilet and water system servicing points for evidence of leakage and satisfactory condition of sealing arrangements in aircraft audit programmes.
- Where leaks are found prior to flight and cannot be rectified, the system should be drained and the toilet placarded INOPERATIVE – reference should be made to the aircraft's MEL.
- Where dents/damage to engine intake lips, compressor blades, stabilizer leading edges etc. are seen with no readily apparent reason for such damage, consideration should be given to the damage having been caused by the detachment of ice from toilet or water system servicing points forward of the damaged area.
- Where blue streaking/staining from toilet servicing panels is evident with nil apparent leaks, consideration should be given to the possibility of inadequate servicing procedures having been used.
- Whilst obviously all Airworthiness Directives applicable to such systems must be complied with all non mandatory service bulletins and modifications should be carefully assessed for application to such systems.
- Toilet and water system servicing point sealing arrangements must be maintained serviceable at all times and should receive the same level of attention as afforded to any other aircraft system.
- Leakage from otherwise fully serviceable toilet systems has on occasions been caused by items such as soap dispensers and disposable nappies being placed in toilets and becoming lodged under the toilet dump valve assembly. Placards located adjacent to the toilet showing prohibited items should be maintained legible at all times.
- Toilet systems servicing panel areas should be kept clean and free of staining to assist in the early detection of leaks. Following any leak rectification, maintenance personnel should ensure that any staining/contamination is removed otherwise any future leaks may well go undetected. Operators should consider the implementation of a cleaning programme for toilet servicing panel areas to assist the prompt detection of leaks.

REMEMBER

THE ONLY ACCEPTABLE LEAK IS NO LEAK!

APPENDIX 20–1 Soft Metal Shims

1 Introduction

This Appendix supersedes Airworthiness Notice No. 12 Appendix No. 1 Issue 1 dated 1 March 1973 which was originally issued to warn operators of the possible failure of a power control bracket fitting to the elevator.

2 Background

An investigation into the failure of a power control bracket fitting to an elevator revealed that soft metal shims were embodied between the bracket and the elevator, apparently for assembly alignment and adjustment. Small diameter special tapered bolts were embodied in shear and set bolts in tension, but the effect of these was quickly lost after tightening due to setting or extrusion of the soft metal shims.

3 Airworthiness Considerations

In this type of assembly it is important that the initial torque loading at manufacture should be maintained throughout the life of the assembly. This object was defeated by the use of soft metal shims and thus a design feature which had been proved by experience to be undesirable, was repeated and created a serious hazard.

APPENDIX 20–2 Crowded Ball Races

1 Introduction

This Appendix supersedes Airworthiness Notice No. 12 Appendix No. 2 Issue 1 dated 1 March 1973 which was originally issued to warn of the possibility of a control shaft becoming completely jammed.

2 Airworthiness Considerations

- 2.1 Crowded ball races have no cage, and the balls are placed in position by forcing them through assembly slots in the inner and outer races. Only a small amount of interference between the ball and the slot is possible during assembly, with the result that excessive wear (which can be caused by rusting or faulty manufacture) can leave the balls free to re-enter the assembly slot. The inner race can then become locked to the outer race and, in addition, loose balls may drop out and possibly create a further hazard.
- 2.2 Cases have arisen with such bearings in which the clearances became sufficiently large for a ball to move from its proper track into the assembly slot and yet not escape completely because of the configuration of the bearing on the shaft. In this position, the ball completely jammed the control shaft on which it was used.
- 2.3 Among many ways of preventing this kind of hazard is the use of shaped washers alongside the bearing to prevent the balls moving sideways far enough to re-enter the slot.

APPENDIX 20–3 Unauthorised Alteration of Parts

1 Introduction

This Appendix supersedes Airworthiness Notice No. 12 Appendix No. 11 Issue 1 dated 7 November 1973 which was originally issued to alert operators of accidents occurring as a result of unauthorised alterations to parts.

2 Background

Fatal accidents to UK registered civil aircraft have occurred after, and at least in one instance, as a result of, the unauthorised alteration of parts in such a way as to enable their incorrect assembly and functioning.

3 Airworthiness Considerations

- 3.1 No part which could affect the safety of an aircraft may be altered other than in accordance with drawings or instructions from the manufacturer or an appropriately approved organisation.
- 3.2 In the assembly of all parts, but particularly when any change which could affect interchangeability has been made, care must be taken to ensure that the correct part for the particular purpose is fitted, that it is fitted correctly, the right way round, and if a working part, that it and the system of which it is part, works in the correct sense and throughout the correct range.
- 3.3 No alteration may be made to nullify a feature provided to prevent wrong assembly.

APPENDIX 20–4 Maintenance and Re-installation of Pipes and Cable Looms

For the purpose of this Appendix, the term pipe is intended to cover small bore flexible or rigid pipes carrying fluid at either positive or negative pressure relevant to ambient and typically supported by 'P' clips or 'B' nuts.

1 Introduction

This Appendix supersedes Airworthiness Notice No. 12 Appendix No. 42 Issue 1 dated 16 March 1990 which was issued following a number of incidents which occurred due to poor or incorrect routing of pipes and cable looms.

2 Background

- 2.1 A number of incidents have been reported in which the failure of pipes and cable looms has occurred due to poor or incorrect routing, incorrect or absent structural attachments and in the case of rigid pipes, corrosion and chafing at 'P' clips and 'B' nut locations.
- 2.2 Manufacturers' recommended maintenance requirements and standard practices have always stressed the need to conduct adequate inspections of pipes and cable looms in areas of poor and limited access during scheduled maintenance inspections and non-scheduled maintenance. However, it is felt appropriate to re-emphasise the

need to conduct satisfactory inspections and re-installations of pipes and cable looms following maintenance activities.

3 Airworthiness Considerations

- 3.1 Maintenance organisations and maintenance personnel must be alert to the need to ensure the satisfactory condition of all pipes and cable looms with regard to chafing, correct routing and adequate structural attachment, following scheduled maintenance inspections, non-scheduled maintenance and the installation of approved modifications. Attention should also be paid to the re-installation of pipes and cable looms in accordance with the manufacturer's original installation.
- 3.2 When inspecting pipes, care should also be taken to ensure that no corrosion exists under 'P' clips and 'B' nuts. Particular attention should be paid to pipes located in areas of adverse environmental exposure such as wheel bays, wing trailing edges and undercarriages.
- 3.3 For additional information related to cable looms see CAAIP Leaflet B-180 Appendix 24–3 and for Stainless Steel pipes see CAAIP Leaflet B-180 Appendix 70–3.

APPENDIX 20–5 Hazards of Damage Caused by Arc Burns

1 Introduction

This Appendix supersedes Airworthiness Notice No. 12 Appendix No. 29 Issue 1 dated 1 April 1983 which was originally issued following a fatigue failure of a titanium alloy fan blade initiated by damage remaining from an arc burn.

2 Background

- 2.1 An engine's titanium alloy fan blade failed in fatigue that had emanated from an area of local blending on the blade leading edge. The failed airfoil may have been contained initially by the fan containment casing but the imposed impact and rotor unbalance loads caused damage such that together with aerodynamic loads, there were consecutive separations in-flight of the nose-cowl assembly and of the fan containment casing which then damaged the airframe and another engine.
- 2.2 The blending is believed to have met the acceptable standards for removing visible damage, but had been applied to remove a burned area which had been caused by a high energy electrical arc contacting the blade's leading edge. Subsequent laboratory examination of the failed blade's microstructure indicated that the blending operation had not removed all of the arc burn's heat affected area, one remaining portion of which became the origin of a fatigue crack.
- 2.3 There have been other cases of fan blade failure from arc burns. In addition, a failure of a helicopter rotor blade has been attributed to an arc burn which had occurred during an anodising process in manufacture.
- 2.4 The accidental occurrence of electrical arcs produces localised melting and rapid subsequent cooling of materials, thereby causing a local degradation of material properties, which may then lead to cracking (cracks for evaluation of fatigue crack growth in test specimens are often 'started' by means of low voltage short duration electrical arcs used to introduce a flaw in the material).

- 2.5 An arc burn may be evidenced by a small circular or semi-circular heat-affected area on the surface which may contain shallow pitting, re-melting or cracking. Usually a dark blue oxide discoloration is associated with the heat-affected area (paint protected materials are not immune, and paint burns could be indicative of arc burn damage in the component).
- 2.6 Most manufacturers provide detailed instructions for the rectification of the large scale arc burn damage caused by lightning strikes, but they may not all adequately cover the possibility and hazards of arc burns from electrical equipment used during maintenance and overhaul.

3 Airworthiness Considerations

- 3.1 Minimise the possibility of arc burns by proper maintenance of all electrical equipment used in the vicinity of aircraft/engine components.
- 3.2 If any electrical equipment, including its leads, is found to be faulty or has blown a fuse, inspect carefully for evidence of arc burns on any item which the equipment has been near.
- 3.3 Do not regard arc burns as 'normal' damage in determining the actions to remove the damaged area – in the absence of any published specific instructions regarding removal of arc burn damage, obtain advice from the manufacturer or reject the part.

APPENDIX 20–6 Hydraulic Fluid Contamination

1 Introduction

This Appendix supersedes Airworthiness Notice No. 12 Appendix No. 33 Issue 2 dated 10 December 1986 which was originally issued to warn helicopter operators of the effects of chlorine contamination of hydraulic fluid.

2 Background

- 2.1 A shut off valve, integral with a flying control actuator, jammed due to internal corrosion and could not function correctly causing an accident to a large helicopter. The corrosion had been induced by chlorine contamination of the hydraulic fluid.
- 2.2 Whilst manufacturers' publications and accepted maintenance practices have always stressed the need for scrupulous cleanliness when dealing with hydraulic components, there has been little emphasis on the potential hazards which may result from the vulnerability of both phosphate ester and mineral based hydraulic fluids to contamination by cleaning solvents or water.

3 Airworthiness Considerations

- 3.1 Cleaning fluids in general contain, or are based on, chlorinated solvents. These solvents, or their residues, can combine with excessive amounts of water, which are often found in hydraulic systems, to form hydrochloric acid. This acid will attack internal metallic surfaces in a system, particularly ferrous materials, and produce rust-like corrosion. Such corrosion is virtually impossible to stop and component overhaul and thorough system decontamination is usually necessary to restore the system to a serviceable condition.

- 3.2 Residual contamination by chlorinated solvents during hydraulic system maintenance or component overhaul must be prevented. When chlorinated solvents are used, care should be taken to ensure that all surfaces, including connectors associated with hydraulic test rigs of ground power supply sources, are free from such residual solvent before assembly or connection to the aircraft system.
- 3.3 All overhaul agencies and maintenance personnel must be alert to this significant but obscure hazard and are advised to review their maintenance procedures to ensure that chlorinated solvents cannot get into hydraulic systems or components.
- 3.4 In some fluids, an excess of water, even in the absence of chlorine contamination, may result in a build-up of acidity, or the formation of gelatinous deposits which can clog filter elements and small passageways, therefore, hydraulic fluid in aircraft systems and test rigs should be periodically checked for total acidity and water content to ensure these parameters remain within the appropriate aircraft manufacturer's recommended limits.

APPENDIX 22–1 Auto-pilots on Light Aircraft

1 Introduction

This Appendix supersedes Airworthiness Notice No. 12 Appendix No. 9 Issue 1 dated 7 November 1973 which was issued following an incident where the aileron control of a light aircraft jammed.

2 Background

The aileron controls of a light aircraft recently jammed in flight; the pilot managed to maintain control by means of the rudder. The incident was caused by the corrosion and seizure of a bearing which supported the output drive gear of an auto-pilot roll servo motor. A slipping clutch associated with this gear had also seized. There was no weak link in the drive between the servo motor and the aileron control system.

3 Airworthiness Considerations

- 3.1 The type of auto-pilot involved in the incident is installed in many light aircraft, and the use of a slipping clutch to protect the aircraft against excess servo motor torque, or a jammed servo motor, is a feature common to other types of light aircraft auto-pilots. It must be realised that such a slipping clutch does not provide protection against jamming where seizures occur in the drive between the clutch and the flying control system.
- 3.2 In the operating instructions for the aircraft involved in the incident, the pilot is advised to check the system prior to each flight to ensure that the clutch can be slipped. Wherever practicable a similar check should be made by pilots of all light aircraft fitted with auto-pilots in which slipping clutches are incorporated.
- 3.3 Any auto-pilot servo motor (including bearings and attachments) which is connected so as to be part of the Flying Control Installation, must be subjected to the same maintenance checks as those called up in the Maintenance Schedule for the Flying Control Installation.
- 3.4 At all times the manufacturers' recommendations for operating and maintaining the autopilot must be adhered to.

APPENDIX 24–1 Electrical Power Supplies – Light Aircraft Care and Maintenance

1 Introduction

This Appendix supersedes Airworthiness Notice No. 12 Appendix No. 21 Issue 2 dated 18 August 1989 which was originally issued following incidents involving a total loss of electrical power on light aircraft.

2 Background

Investigations into incidents involving total loss of electrical power supplies on light aircraft have shown that insufficient care was taken in the maintenance of the major components of the electrical system.

3 Airworthiness Considerations

- 3.1 A single fault, or a single fault plus a dormant fault, may cause the loss of electrical supplies. For example:
- If the battery becomes disconnected from a generation system using 'commercial' type alternators, instability may occur with the subsequent loss of the output of both alternators and result in the total loss of electrical power.
 - In a twin-engined aircraft, a slack drive belt may operate quite adequately when both generators/alternators (generator) are sharing the load, but may slip should the other generator fail, with the resultant loss of output from both and leaving the electrical system demands dependent on the battery. On a single-engined aircraft, the belt may slip with increasing electrical load on the system, with similar results.
 - Faults in the load-sharing system may effect both generators, possibly to such an extent as to result in the loss of output from them both.
- 3.2 While there are obviously many other faults which may result in generation system failures, these examples are quoted since they have occurred a number of times in service.
- 3.3 Should both generators fail and difficulty be experienced in re-setting, it may be possible to re-set one of them by reducing the electrical load to a minimum. Having re-set one, it is advisable not to attempt to re-set the other, since this may cause permanent loss of the output of both.
- 3.4 The attention of Owners and Operators is drawn to the necessity for ensuring that the following items are checked periodically:
- The battery and its control relay must be correctly installed and the battery terminals must be free from corrosion and correctly tightened.
 - Voltage settings and load-sharing adjustment (where applicable) must be correct.
 - All cable connections must be secure with locking devices in place and with end fittings showing no signs of fatigue fracture or corrosion. Earth connections are equally as important as the positive connections.
 - Drive belts for generators must be checked to ensure that they are in good condition and correctly tensioned.
- 3.5 It is recommended that these checks should be carried out approximately every 50 flying hours or six months, whichever is the sooner. The appropriate Maintenance

Schedules should be reviewed and, where necessary, adjusted to take these recommendations into account.

- 3.6 The operation of the appropriate indicators and failure warning devices should be checked daily or during the pre-flight drill.
- 3.7 Whilst the CAA considers that the situation should be contained by the diligent application of maintenance procedures, owners and operators may, nevertheless, wish to consider modifications to improve the reliability of their own particular aircraft by, for example, the introduction of an emergency battery to act as a power source for vital services should the main electrical system fail. Such batteries have already been introduced on certain aircraft, and installation information is available.

APPENDIX 24–3 Electrical Cable Failure

1 Introduction

This Appendix supersedes Airworthiness Notice No. 12 Appendix No. 32 Issue 2 dated 10 December 1986 which was originally issued following incidents in which damage to the insulation of electrical cables was the cause of an electrical system failure.

2 Background

In a well-documented occurrence, damage to the insulation of electrical cables, caused by defective circuit identification printing, was a contributory factor to a significant aircraft electrical system fault in flight. The incorrect application of hot stamp printing resulted in excessive penetration of insulation and a group of individual cable damage sites coincided physically in a loom. Fluid from a leaking toilet waste system contaminated the cables in the damaged area and severe electrical arcing occurred which was of sufficient intensity to rupture the damaged cables and also others in close proximity.

3 Airworthiness Considerations

- 3.1 Study of the pertinent factors has indicated that in addition to avoiding damage to cables during installation, modification or repair activity, there is a need for vigilance in the following areas:
- a) Fluid contamination of electrical equipment is obviously to be avoided but it is particularly necessary to appreciate that certain contaminants, notably that from toilet waste systems (which is saline) and fluids which contain sugar, such as sweetened drinks, can induce electrical tracking of degraded electrical cables and unsealed electrical components.
 - b) Cable looms are particularly vulnerable to liquid contamination because they can provide a drainage path. Care should be taken to route cables away from known areas of possible leakage but, should contamination occur, cable looms must be thoroughly cleaned and dried and any unsealed electrical items removed to workshops for examination.
 - c) In areas where it is not possible to provide segregation between electrical cables and pipes which carry fluid, it is good design practice to keep pipe joints to an unavoidable minimum. The fitment of drip shields or drained enclosures to joints in liquid waste systems is recommended.

- d) The CAA will pay additional attention to the quality control of hot stamp printing applied by cable users and will expect to see appropriate testing of cables after printing. The preferred method of ensuring that the insulation of printed cable has not been degraded is to employ a High Voltage Test using one of the systems defined in British Standard BS 3G 230: 2000 Test 16. Continuous testing is not required provided an adequate sample is tested whenever any machine setting is altered, including changes of alpha numeric characters.
- e) It is important to note that hot stamp printing may only be applied onto cable types and sizes which have been certified as capable of accepting such marking. Cable manufacturers whose products have approval under BCAR Section A, Chapter A/B4–8 procedures are able to give appropriate guidance on a Declaration of Design and Performance (DDP) and they will be able to advise on suitable test and inspection methods.
- 3.2 It has been further reported that certain types of widely-used cable insulation are susceptible to 'arc track' when seriously abused in service. The failure detailed in paragraph 2 related to a wet 'arc tracking' condition and designers of installations should be aware that, in addition to the factors noted in paragraph 3.1, it is recommended that cable selection should include evaluation of 'wet-arc tracking' characteristics. BS 3G 230: 2000 defines test conditions for aircraft electrical cables and Test 42 provides a test regime which facilitates comparison between cable types. Cable manufacturers are evaluating their existing products using Test 42 criteria and in consequence some new cable manufactures have been developed.
- 3.3 A further failure mode which has been established by laboratory testing and widely canvassed, is that of 'dry-arc tracking', which is a secondary failure condition resulting from the short circuiting of cables. The primary aim of the testing was to explore 'battle damage' failure but it may be postulated that cable to cable abrasion or other 'cut-through' faults can permit intense local heating at power levels which are well within the short term no-trip characteristic of the associated electrical protection. In such conditions some insulation materials can form a conducting char and if this extends to cables not involved in the original fault, a 'cascade' failure may develop. The CAA and other agencies are seeking to establish if this failure mechanism has any relevance to civil aircraft beyond placing further emphasis on the need for good design, installation and maintenance of electrical interconnect systems.
- Personnel engaged in servicing of aircraft are reminded that the discovery of a potentially hazardous failure condition during maintenance or fault finding may well justify the raising of a Mandatory Occurrence Report (MOR). In the context of this Appendix, any disruptive failure of electrical cables would warrant such a report. Physical evidence should be retained for investigation.

APPENDIX 24–4 Thermal Circuit Breakers

1 Introduction

This Appendix supersedes Airworthiness Notice No. 12 Appendix No. 40 Issue 1 dated 16 September 1988 which was originally issued to clarify the role of electrical thermal circuit breakers.

2 Background

There would appear to be some misunderstanding of the intended role of electrical thermal circuit breakers, which is reflected in the selection, maintenance and in-flight use of such devices. This Appendix relates to push button operated single pole and three pole units but does not embrace the simple thermal devices which are not capable of being manually switched (such units are occasionally fitted to light aircraft).

3 Airworthiness Considerations

- 3.1 The basic function of a thermal circuit breaker (CB) is to detect an electrical overload condition which is, for rating and calibration purposes, assumed to be a constant current. The first point to note, therefore, is that electrical faults may be of a form which do not represent an overload to a given CB and that faults seldom present a constant value of current for a continuous time. The CB can only be expected to isolate faults which will overload the circuit and therefore any protection which is afforded to a consuming equipment, such as a motor, is often a matter of chance. Where consumer equipment requires protection against an internal fault or functional overload, then an appropriate form of current or temperature sensing protection needs to be incorporated as an integral part of the design.
- 3.2 Distribution faults of a 'splashing' nature, which cause intermittent currents of high instantaneous value, will also be undetected by a thermal CB unless the integral sum of the fault currents does constitute an overload within the relevant trip characteristics. It follows that, where other constraints permit, the current rating of CBs should be selected at the lowest value consistent with the avoidance of nuisance trips caused by, for example, high ambient temperatures within the CB enclosure. Such derating of detection below the nominal level appropriate for a given cable size will afford a greater possibility of fault protection for fault conditions which do not conform to the idealised overload failure pattern as represented by circuit breaker characteristic curves.

4 Operational Use

- 4.1 In-flight operational use of CBs will usually involve the action of resetting a circuit breaker which has tripped because of an electrical overload or fault. Clearly the re-establishment of electrical power to a circuit which is at fault does involve, however slight, an element of risk. Accordingly, flight crews should be advised not to attempt to reset CBs in flight for other than essential services and, even then, only when there is no clearly associated condition of smoke or fumes. A second reset should not be attempted.
- 4.2 Cabin crew should be advised that CBs associated with domestic services should not be reset in flight because, by definition, the circuits involved are mostly within the passenger areas and the inconvenience caused by the loss of service would not justify any possible distress occasioned by 'electrical smells'.
- 4.3 A Technical Log entry should be made whenever any circuit breaker trips when the aircraft is in operation and a thorough investigation should subsequently be undertaken, including a visual inspection of the appropriate cable harnesses wherever possible (see CAAIP Leaflet B-180 Appendix B-180).

5 Maintenance Considerations

- 5.1 It has become apparent that the progressive development of the Maintenance Review Board determining scheduled maintenance has led to a significant erosion of maintenance checks of circuit breakers. Users are reminded that there is a continuing duty to monitor the performance of equipment and that items such as circuit breakers which are largely passive in nature should be assessed for dormant faults.
- 5.2 As a minimum and where Maintenance Schedules do not require a high level of checking, all CBs which are not regularly exercised by mechanical switching should be checked for correct mechanical operation by performing two manual switching cycles at periods of not more than two years. The necessary action should be taken to revise Maintenance Schedules as appropriate.
- 5.3 Where aircraft maintenance organisations are required to undertake scheduled calibration checks of circuit breakers, corresponding reliability data should be gathered. Simple pass/fail criteria is not sufficient for circuit breakers, or indeed any other equipment, where an analysis can make a significant contribution to reliability and airworthiness.
- 5.4 When installing CBs, any units which have not been supplied directly from an Approved source or have been stored for two years or more, should be checked for correct mechanical and, ideally, electrical operation before fitment to an aircraft.

APPENDIX 24–5 Battery Terminal Failure – GA Aircraft

1 Introduction

This Appendix supersedes Airworthiness Notice No. 12 Appendix No. 44 Issue 1 dated 12 November 1990 which was originally issued following incidents of loose, melted or detached battery terminals on GA aircraft.

2 Background

There have been a number of reported incidents of loose, melted or detached terminals of batteries in service on GA aircraft. In one particular case, a light twin-engined aircraft experienced a fire in the nose compartment, on the ground, whilst attempting to start an engine. The fire resulted from ignition of hydrogen gas (emitted from the battery) caused by arcing of a loose battery terminal. Upon examination after the incident, the positive battery terminal had become completely detached with the top of the battery badly deformed as a result of the fire.

3 Design Considerations

- 3.1 Following this incident, the CAA issued a letter to Operators (LTO No. 795) giving details of the dangers associated with loose battery terminals.
- 3.2 The terminals are basically square headed brass bolts, tinned and fluxed and placed with thread uppermost in a lead casting assembly. Cables are held on to the terminal post by a wing nut so as to maintain contact between the cable terminal pad and the battery terminal post.
- 3.3 The FAA conducted their own investigation with the manufacturers of the batteries and a General Aviation Airworthiness Alert No. AC 43–16 was issued. This alert

recommended certain actions as preventative maintenance which is supported by the CAA and are outlined below:

- a) Ensure that before installing any battery into an aircraft, it is the correct model for the installation.
- b) Inspect the battery terminal and stud. If it is at all loose or deformed, it should not be installed.
- c) Ensure that the battery cable terminal is clean and free from corrosion, oxidation and contamination.
- d) Ensure that the battery cable terminal fits correctly on the terminal.
- e) Ensure the battery terminal post wing nut is correctly tightened (it should not be possible to move the terminal lug by hand).

CAUTION: Do not overtighten the terminal post wing nut. Overtightening may result in deformation of the terminal post material which will eventually result in the terminal becoming loose in service.

- 3.4 Personnel are reminded that the discovery of a potentially hazardous failure condition during maintenance or fault finding may well justify the raising of a Mandatory Occurrence Report (MOR). In the context of this appendix, any broken or detached battery terminals discovered would warrant such a report. Physical evidence should be retained for investigation.
- 3.5 CAAIP Leaflet B-180 Appendix 24-1 also deals with battery terminals.

APPENDIX 24-6 Lithium Batteries

1 Introduction

- 1.1 The development of primary cells employing Lithium in combination with other materials has resulted in the availability of batteries with energy densities which are very significantly higher than those which have previously been achieved. In-service experience and the results of safety tests carried out to Lithium batteries has shown that there is a potential for hazard. It is therefore necessary for users to consider the possible hazardous consequences of abuse or failure of such devices and this Appendix considers the safeguards which should be observed.
- 1.2 Lithium sulphur dioxide cells have been available for aircraft use for many years but early experience showed the risk of disruptive failure if batteries did not incorporate adequate protective devices. In the USA Technical Standard Order C97 was produced and this has represented an acceptable standard for Lithium Sulphur Dioxide cells, but because other Lithium based systems have now been developed, TSO C97 has naturally become outdated. In 1984 the CAA sought the assistance of the BSI in preparing a British Standard to cover all known systems which was published as British Standard G239; this standard has now been updated and re-issued as 2G 239. Since initial publication of this Appendix, advances in Lithium technology have resulted in Secondary (rechargeable) Lithium batteries becoming available. At present no appropriate standard is available covering the use of these batteries on aircraft. The CAA have again sought BSI assistance in formulating a standard similar to 2G 239 for secondary Lithium batteries. It is the policy of the CAA to continue to implement BS 2G 239 and, in the absence of a specific standard for secondary Lithium batteries, implement the safety requirements defined in BS 2G 239.

NOTE: EASA has published ETSO-C97 which is equivalent to the FAA TSO-C97.

- 2** Intending users of Lithium batteries, as defined in paragraph 3, are advised that the CAA will seek positive assurances regarding the design and build standard of such batteries. The following guidelines should, therefore, be observed:
 - 2.1 The specification for the battery should embrace all the relevant requirements of BS 2G 239.
 - 2.2 The procuring design authority should invoke BCAR Chapter A3-3 requirements for the approval of a Controlled Item and a Declaration of Design and Performance to the format given in BS 2G 239 should be obtained in all cases. This will normally involve a supplier who holds an appropriate approval to BCAR Chapter A8-1 as a Group A1 Company, or EASA Part 21 subpart G, Production Approval (as appropriate).
 - 2.3 Due regard should be taken of the possibility that some types of cell may fail such that gases will be vented. Such failure is usually associated with accidental electrical charging, the puncturing of cells, or the application of heat. It follows that Lithium batteries should not be installed in proximity to passengers or flight crew if any of these conditions can be foreseen.
 - 2.4 The CAA and EASA have approved suitable organisations for the design and manufacture of Lithium batteries. The assembly of batteries by unapproved organisations is not acceptable unless the user can, under the terms of his own approval, demonstrate that such batteries do satisfy the requirements of BS 2G 239. Continuing control of the design standard and production quality of such items should be maintained.
 - 2.5 Where Lithium batteries have been installed in aircraft prior to the issue of this Appendix evidence should be sought that such batteries were approved to TSO C97 or that the safety requirements of BS 2G 239 are met. Should such assurance not be available, as a minimum, evidence of safe operation under the abusive failure conditions which are relevant to individual installations should be sought.
 - 2.6 When batteries are removed from aircraft at the end of life, it is in the interest of safety that the disposal procedures given in BS 2G 239 be followed.
- 3** For the purpose of this Appendix a single cell fitted in aircraft as a Line Replaceable Unit (LRU) may be taken as representing a battery and thus be eligible for Accessory Approval (BCAR Chapter A3-3). However, small button cells which are hard wired within equipment may be considered as a component part of the equipment (as defined in CAAIP Leaflet 39-10) and be approved within the overall type test. Such cells should be fully assessed by equipment designers, who should be aware of the precautions which need be taken to avoid abusive failures and be able to demonstrate that the effects of failure have been considered. They may, therefore, seek a Declaration of Design and Performance from the cell manufacturer as supportive evidence.
- 4** Overhaul manuals for equipment containing Lithium batteries or cells should include cautionary notes and refer to the methods of disposal given in BS 2G 239. Attention should be drawn to the corrosive nature of any chemical contamination which may result from disruptive failure, with appropriate advice on cleaning methods.
- 5** Attention is also drawn to Guidance Note GS43 entitled 'Lithium Batteries' which is published for the Health and Safety Executive by HMSO.

APPENDIX 24-7 Aircraft Electrical Cable SAE-AS 22759/16, 17, 18, 19 and MIL-W-22759/16, 17, 18 and 19

Changes have been introduced to reflect the cancellation of the MIL-W specification 22759 in 2004, and replacement by the SAE-AS series of 22759 specifications now in force.

1 Introduction

This Appendix supersedes Airworthiness Notice No. 12, Appendix 64, Issue 3, dated 28 September 2005.

2 Background

The AS22759 specifications that are maintained by the Society of Automotive Engineers (SAE) supersede the MIL-W-22759 specifications that were cancelled in 2004. Electrical wires meeting either the SAE-AS 22759/16, 17, 18 and 19 specifications, or the MIL-W-22759/16,17,18 and 19 specifications have a single non-cross linked ETFE extruded insulation.

Although not generally recommended by large aircraft manufacturers, this type of wire construction is and continues to be in widespread use within the aircraft industry. The acceptability of this wire type is referenced in a number of industry and regulatory documents, e.g. FAA AC 43.13-1B, FAA Policy Memorandum Ref No.PS-ACE100-2004-10023 and SAE AS50881.

Although this wire can be suitable for a wide range of applications it is recognised that there are a number of performance limitations with this type of wire construction that should be reviewed before the wire can be assessed as suitable for use in a specific application.

3 Limitations

The following are known performance limitations:

The insulation of this wire type can lose its mechanical properties (begin to melt) when the wire is subjected to high fault currents or is influenced by an external heat source.

The single extrusion insulation provides limited protection against the propagation of insulation surface damage through to the conductor. Cracks and nicks can readily propagate through to the conductor.

Generally, modern approved airframe wires have two or more insulation layers specifically to provide stress relief protection against the propagation of insulation surface damage through to the conductor.

Non-crosslinked ETFE insulation may not meet expected abrasion or cut-through performance levels, e.g. EN3475-503.

Although the flammability test method described in SAE-AS 22759/16, 17, 18, 19 and MIL-W-22759/16,17,18,19 provides a good assessment of the flame characteristics of this wire, the test method does not exactly correlate to the 60° flame test in the Certification Specifications (e.g. CS 25), which is necessary to show compliance.

4 Discussion

Aircraft equipment should always be assessed for its suitability for use (fit for purpose) and compliance with the relevant certification requirements. The use of this type of wire is not automatically acceptable for the reasons stated above. Particular care must therefore be taken when selecting this wire type to ensure that it meets all installation and regulatory requirements and is fit for its intended application.

5 Requirement

Users of SAE-AS 22759/16, 17, 18, 19 and MIL-W-22759/16,17,18,19 wire and similar wire constructions shall determine the following specific data and information for each application of the wire to demonstrate compliance with the applicable airworthiness requirements:

The installation of the wire shall be assessed as appropriate to its intended application and environment. The proximity of external heat sources shall be considered in particular.

When selecting wires that are different to the existing manufacturer's installed wiring, the performance characteristics of the existing wiring and the new wiring shall be compared and any differences shall be determined as acceptable.

The wire must be kept within acceptable operating parameters that accommodates the circuit protection levels, as well as environmental and circuit heating. (Note: it is undesirable to allow a temperature rise due to electrical heating of more than 40°C above ambient).

The installation design shall mitigate the abrasion hazard to the cable insulation. It shall also be established that the cable is compatible with other wire constructions in the same bundle.

It shall be shown that the wire type to be used meets, as a minimum, the appropriate airworthiness fire test requirements (e.g. CS 25.869 (a)(4), Appendix F Part 1(a) (3), CS 23.1359 (c) Appendix F, CS 27.1365(c), CS 29.1359(c) etc.)

The design assessment of the wire selection shall establish any maintenance or inspection procedures with appropriate intervals to ensure the continued airworthiness of the wire insulation, as appropriate.

APPENDIX 25–1 Single Lock Airframe Seat and Furnishing Attachments

1 Introduction

This Appendix supersedes Airworthiness Notice No. 12 Appendix No. 37 Issue 1 dated 6 November 1987 which was issued following an accident in which passenger seats had become detached from the floor.

2 Background

Investigations into an aircraft accident revealed that some of the passenger seats had detached at the floor attachment points, resulting in injury and fatalities of passengers. The fittings used, in this particular case, were of a claw and locking collar device on the seat legs mating with mushroom headed studs on the cabin floor. The fitting part number was D1416–2 manufactured by General Logistics in America.

Normally the seat leg fitting and collar have an inter-connected secondary locking device. On the seats in question, the seat leg fitting was of an early design that did not have the secondary locking device. It is believed that impact forces allowed the locking collar to be driven out of engagement allowing the claw to disengage from the floor attachment, thus releasing the seats.

3 Airworthiness Considerations

- 3.1 All aircraft should have their seats and other items of furnishings (e.g. Galleys) inspected for this type of fitting. Where such fittings are found, they should be replaced with a style of attachment fitting which requires positive manual actions to release it. If it is intended that the claw and mushroom head type be retained, then they should be of a type possessing a minimum of four groups of holding claws plus two interconnected locking devices. The second locking device must be of a type that requires a positive physical action to operate it before the primary claw locking collar can be moved.
- 3.2 All future designs for furnishings should use fittings similar to those described in paragraph 3.1 above.

APPENDIX 25–2 Stowage and Accessibility of Lifejackets

1 Introduction

This Appendix supersedes Airworthiness Notice No. 12 Appendix No. 27 Issue 1 dated 2 October 1981 which was originally issued as a result of an incident where passengers had difficulties in retrieving lifejackets.

2 Background

An enquiry into an accident to a UK passenger transport aircraft revealed that some passengers experienced difficulty in obtaining the valise containing the lifejacket (hereinafter referred to as the 'valise') which was stowed underneath their seat. Subsequent investigation showed that because the stowage pouch in which the valise was retained was not positioned close to the front edge of the seat pan, difficulty arose for some passengers in locating and releasing the valise.

3 Maintenance Checks

- 3.1 Attention of operators and manufacturers is drawn to the need for careful interpretation of the requirements for accessibility of safety equipment* as they relate to the occupants of aircraft, and particularly passengers, having ready and easy access to the valise during all phases of the flight. These requirements apply not only to the initial certification of the aeroplane type but also to modifications to seats, seating arrangements, and equipment stowage arrangements.
- 3.2 Interpretation of the requirement for ease of accessibility will in most installations, necessitate the valises, when stowed under seats, being located near to the front edge of the seat pan, arranged so as to allow the occupant of the seat readily to remove the valise from the stowage pouch, which may be a two handed operation, in the shortest possible time. The method for removing the valise from the stowage pouch should not, therefore, necessitate any extensive body movement by a seated passenger with safety belt fastened. Furthermore, the possibility of the valise being

ejected or falling from its stowage pouch onto the cabin floor either during normal operation or in an emergency should be minimal.

* EASA Certification Specification (CS) 25.1411.

APPENDIX 25-5 Seat Belts in Light Aircraft - Orientation of Stitched Joints

1 Introduction

This Appendix supersedes Airworthiness Notice No. 12, Appendix 62, Issue 1 dated 29 October 2001 which was issued as a result of a fatal accident.

- 2 An investigation into a fatal accident involving a light aircraft concluded that the seat belt failed during a forced landing. The orientation of the stitched joint on the harness and its interaction with a hard object, probably a trouser belt buckle, was cited as the probable cause of the failure.

3 Background

A high proportion of light aircraft seat belts have the release box, tongue and overlap stitching positioned so that they fall well to the side or behind the occupant's body when installed and adjusted. These belts are considered satisfactory and are excluded from this notice. Care should be taken to ensure that any overlapped joints do fall behind the body on all occasions allowing for all reasonable variations of adjustment of the seat belt to accommodate a full range of adult human body height and girth.

- 4 Where the Original Equipment Manufacturer (OEM) provides instructions on the installation of their seat belts / harnesses, these should be followed.
- 5 In the absence of OEM instructions, the CAA would advise using the following best practice.
- 5.1 During routine maintenance and inspection by owners, the Popular Flying Association, the British Microlight Aircraft Association, licensed aircraft maintenance engineers and approved maintenance organisations, the joint between harness webbing and metal components (release boxes, tongues and adjusters) should be checked.
- 5.2 Where the webbing reversed overlapped and stitched sections are orientated towards the body, if practical, the joint orientation should be reversed.

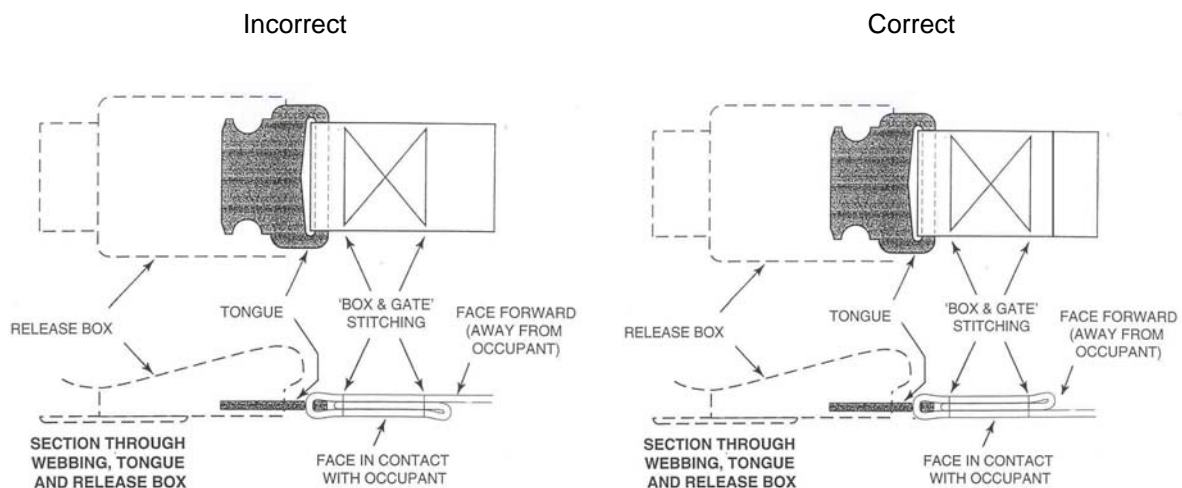

APPENDIX 25-6 Emergency Escape Provisions – Doors and Escape Slides

1 Introduction

This Appendix supersedes Airworthiness Notice No. 12, Appendix 16, Issue 3, dated 18 March 2003.

- 2** During several emergency evacuations, difficulty has been experienced in opening aircraft doors and in deploying the associated inflatable escape slides. Subsequent investigations have shown that the difficulties were due to various reasons such as incorrect rigging of door assist mechanisms, incorrect packing of the inflatable, incorrect installation, safety pins being left in, ageing/wear of items, design shortcomings, fitment of incorrect parts. In a significant proportion of cases however, no reason for failure could be determined.
- 3** Current maintenance requirements include regular inspection, inflation checks and overhaul of the escape slide assembly. However, this may not give an indication of faults or deterioration that could result in the evacuation system not being available for its intended purpose. It is considered therefore, that slides should be tested on the aircraft by opening the doors with the slides armed and a check made to ensure that they deploy and inflate correctly as expected in an emergency evacuation. It is appreciated that this alone will not guarantee correct future operation of all slides on any particular aircraft, but it will provide a level of confidence on the reliability of slide and door operation.
- 4** For all aircraft fitted with inflatable escape slides which are automatically deployed by the opening of emergency exits, slides must be deployed as part of a slide deployment programme on the aircraft by the automatic release and inflation of the slide in accordance with paragraph 4.1 or 4.2 of this Leaflet. It is recommended that when feasible the slide deployment should be carried out by cabin crew, in order to better replicate the emergency condition.
 - 4.1 Every slide on the aircraft should be deployed when it becomes due for overhaul in accordance with the manufacturer's recommended intervals. This period should not exceed 36 months.
 - 4.2 Operators can develop a slide deployment sampling programme, with the agreement of the CAA as part of the Approved Maintenance Programme. This programme must ensure that, on each aircraft type, a sample of at least 10 or 10%, whichever is the greater, of all the exits in the fleet, will have been deployed within an elapsed period of not more than two years. The sampling programme must ensure a reasonably uniform distribution of the exits on that aircraft type. Inadvertent slide deployments should not be included in the slide deployment sampling programme but should still be investigated if the slide fails to deploy correctly.
- 5** Details of the operators slide deployment programme should be included in the Approved Maintenance Programme or Schedule.
- 6** Every operator should define it's own pass / fail criteria which should be accepted by the local Regional Office. The pass / fail criteria should be based on any recommendations made by the aircraft or slide manufacturer and would be expected to include at least the following as failures:
 - Failure of the automatic deployment system (i.e. manual inflation required);
 - Failure of the door to fully open;

- Door assist failure (if fitted);
- Failure to fully inflate;
- Failure to fully inflate within 10 seconds (unless otherwise specified by the manufacturer). Timing is from when the door is initially actuated until the slide is deployed in a useable state;
- Complete failure of slide lights to illuminate

All the above failures must be reported to the authority using the mandatory occurrence reporting (MOR) scheme and to the aircraft type certificate holder.

- 7** To assist in the slide deployment failure investigation, unless otherwise agreed by the CAA, all slide deployments must be recorded by video or other similar means and copies of failed deployments should be held for a minimum of one year or until any MOR or investigation into the failure has been closed. A copy should be made available to the CAA on request.
- 8** All slide deployment failures must be investigated to determine the cause of failure and action taken to prevent similar occurrences. The type certificate holder and escape slide manufacturer should be kept informed of failure investigations and provide assistance where possible. If there are either high levels of slide failures or slide failure causes cannot be determined it may be necessary, in conjunction with the CAA to carry out further deployment tests, increase the paragraph 4.2 sampling size or remove MEL alleviation until a satisfactory level of reliability is achieved.
- 9** For each deployment test the door / slide position, slide part number, pass or fail result, date of manufacture of the slide, failure mode and failure cause should be recorded. Operators should forward a summary of slide deployment testing at regular intervals for each aircraft type to the appropriate CAA Regional Office. This summary should include the following information: Number of aircraft in fleet, number of deployments carried out and overall pass rate for fleet.
- 10** Due to the complexity and safety critical nature of escape slide systems it is recommended that Maintenance Organisations involved in the installation, maintenance and overhaul of escape slides should implement duplicate or independent inspections on critical tasks i.e. slide installation, firing mechanism connections, girt bar installation and rigging, door assist deactivation / slide safety pin removal. Consideration should also be given to the training and competence of personnel involved with the packing, installation, inspection and overhaul of escape slides.
- 11** Operators should review all escape slide continued airworthiness instructions from the type certificate holder and escape slide manufacturer including service bulletins and service letters and consider embodiment where there may be improvements in escape slide reliability.

When an Operator changes maintenance providers i.e. slide overhauler or aircraft maintenance organisation it must review the slide deployment programme to monitor the affects of such changes on the fleet escape slide reliability.

APPENDIX 26-1 Fire Hazards

1 Introduction

This Appendix supersedes Airworthiness Notice No. 12 Appendix 60 Issue 1 dated 18 March 1999.

2 Background

The collection of debris, dust and discarded catering materials found in various areas of aircraft has, in a number of cases, created conditions which have resulted in the outbreak of fire or the production of sufficient fumes for an emergency to be declared.

3 Airworthiness and Operational Considerations

- 3.1 Recently reported flight deck incidents have been attributed to:
- a) the collection of dust around the flight crew foot warmers which subsequently ignited when a high temperature setting was selected;
 - b) fumes produced by shorted electrical equipment as the result of metal objects falling onto connections (as many as 7 metal cutlery knives have been found behind a glare shield).
- 3.1.1 Fumes have also been produced when equipment cooling systems have collected sufficient dust and lint to drastically reduce the airflow. This has on a number of occasions resulted in the smell of burning and/or smoke and emergency in-flight action having to be taken.
- 3.2 Collection of debris in other areas also provides the potential for various electrical sources to ignite combustible materials. Areas such as the void beneath toilet shrouds, behind light fittings and behind sidewall-to-floor panels in the passenger cabin are all places where flammable materials can accumulate. Such accumulations pose an obvious fire risk where electrical equipment and wiring carries sufficient current to create sparks.
- 3.3 Modern interior carpeting often produces large quantities of lint which finds its way into equipment cooling filters and toilet smoke detector sampling tubes often resulting in a reduction in performance or complete failure.
- 3.4 The design of most aircraft is such that large objects cannot fall into sensitive areas, but the omission of gap fillers, seals, electrical terminal shielding and insulating boots during maintenance can create conditions that may initiate a fire.
- 3.5 Maintenance personnel should ensure that design standards of sealing are restored after equipment and panels are refitted and that all loose objects are removed prior to closure.
- 3.6 Maintenance Organisations and Operators should ensure that cleaning programmes are designed to address the removal of clogging and combustible materials at regular intervals.
- 3.7 Quality sampling programmes should address cleanliness standards of aircraft interiors, particularly flight deck areas. Flight crew should be reminded of the dangers of placing any loose objects (including catering) on flight deck glare-shields and pedestals.

APPENDIX 27-2 Flap Systems on General Aviation Aircraft

1 Introduction

This Appendix supersedes Airworthiness Notice No. 12 Appendix No. 19 Issue 1 dated 31 August 1977 which was issued following occurrences of sudden asymmetric flap retraction.

2 Background

Incidents in which aircraft have experienced a sudden asymmetric flap retraction have occurred in the UK. Two of these incidents, one of which resulted in a fatal accident, involved different types of aircraft of United States origin and were caused by malfunctioning of a single 'down' limit microswitch. Subsequent mechanical failures in the flap operating mechanism resulted from repeated high loading when the flap drive system reached the mechanical limits of its travel. Other incidents have been reported in which asymmetric flap retractions have resulted solely from mechanical failure of the flap drive system, e.g. operating cables or flexible drive assemblies.

3 Airworthiness Considerations

- 3.1 During functional checks, it is recommended that particular attention should be paid to the correct operation of all microswitches which affect the travel limits of the flaps and to the condition of all visible elements of the operating mechanism. The Light Aircraft Maintenance Schedule has been amended to require a check based on these recommendations.
- 3.2 Where the 'up' and 'down' limits of flap travel are governed by the operation of single microswitches and one of these microswitches is found to be faulty, the operating mechanisms should be checked for any evidence of static overloading.
- 3.3 Where a modification to introduce an additional microswitch is available, it is strongly recommended that it should be embodied.

APPENDIX 27-3 Control and use of Rigging Pins

1 Introduction

This Appendix supersedes Airworthiness Notice No. 12 Appendix 55 Issue 1 dated 7 November 1997 which was issued as a result of a serious incident involving a large commercial air transport aircraft due to an unofficial rigging pin being left in the aileron control system following maintenance.

2 Background

Whilst carrying out full and free control movement checks prior to take-off, the first officer felt a restriction in the aileron controls. The aircraft captain confirmed there was a restriction and the aircraft returned to the stand where it was found that a bolt, (instead of the correct rigging pin) was installed in the control wheel rigging pin hole at the base of the Captain's control column.

3 Airworthiness and Certification Considerations

3.1 Subsequent investigations revealed that due to the non-availability of the correct rigging pin, (with an attached 'attention getting' red disc/flag), a bolt obtained from a free issue dispensing area was used as an alternative. The correct rigging pin, with a red disc/flag attached, would have been clearly visible at the base of the control column. The bolt used as an alternative was not only difficult to see but effectively camouflaged by two similar and adjacent bolts.

3.2 All aircraft maintenance engineers, and in particular those holding certification responsibilities, are reminded of the need for vigilance when working on control systems and in particular during rigging operations when rigging pins are being used. In order to minimize hazards associated with rigging pins and to prevent future occurrences the following points should be noted:

3.3 Control of Rigging Pins

3.3.1 All rigging pins should be subjected to a form of control in order that their whereabouts can be established. A tool store procedure which could include visual cues in the form of shadow boards is one possibility.

3.3.2 All rigging pins should be subjected to serviceability checks prior to use, with particular emphasis being placed on the secure attachment of 'attention getting' flags/discs.

3.3.3 The installation and removal of rigging pins should be controlled by the use of worksheets, or stage sheets (CAAIP Leaflet B-180 Appendix 5-2 refers).

3.3.4 For maintenance in accordance with Part-145 requirements, AMC145.40(a) states that tools and equipment as specified in the maintenance data should be made available when needed.

NOTE: Part M AMC M.A.402(a) stipulates similar requirements.

3.4 Use of Rigging Pins

3.4.1 Only rigging pins having adequate 'attention getting' devices attached should be used.

3.4.2 Where any maintenance task necessitates installation of a rigging pin(s), an open entry should be made, to this effect, in the controlling Stage Sheet, Technical Log or Additional Work Sheet at the time of its installation.

3.4.3 Upon completion of the maintenance task the rigging pin(s) should be removed and the open entry in the Stage Sheet, Technical Log or Additional Work Sheet appropriately annotated and certified.

3.4.4 Upon completion of any control system rigging operations, full and free movement checks should be carried out as a matter of practice thus providing the final opportunity to locate that forgotten rigging pin.

NOTE: The reader's attention is drawn to CAAIP Leaflet 20-80 Control Systems which contains additional information concerning the use of control system rigging pins.

APPENDIX 27-4 Control Cable End Fittings

1 Introduction

This Appendix supersedes Airworthiness Notice No. 12, Appendix 65, Issue 1 dated 18 March 2003 which was issued as a result of information received from the FAA.

2 Background

In November 2001 the CAA received information from the FAA of a NTSB investigation of control cable end fittings. The NTSB has investigated the failure of flight control cable end fittings on six aircraft. Four of the failures occurred in-flight, although not leading to serious accident or loss of life.

3 Additional end fittings from some of the incident aircraft as well as from four other aircraft were examined and found cracked. Most of the end fittings had fractured or cracked in a transverse manner through the shaft on the threaded end of the fitting close to the spanner/wrench flats. A few showed evidence of cracking in the swaged portion of the fitting.

4 The NTSB investigation identified a number of common features to the failures and cracking of the end fittings:

- The material of manufacture of the fittings was a free machining stainless steel grade containing selenium and a high sulphur content.
- The fittings surfaces were generally corrosion pitted. Where locking wire was wrapped around the fitting it was noted that the pits had a higher density beneath the wire.
- The predominant fracture mode was stress corrosion cracking, initiated at corrosion pits.

5 Stress corrosion cracking only occurs under specific environmental conditions, in susceptible materials when tensile stresses are induced in the material. The end fittings examined were all taken from light aircraft which had been in service for at least 20 years, however the specific environmental conditions that caused the corrosion have not been identified. Although, not all stainless steel end fittings are considered susceptible, it is not possible to identify the grade of stainless steel used for a fitting by inspection.

6 The initial indication of degradation would be surface pitting of the steel. As the attack progresses surface breaking cracks will become evident, and possibly staining and discolouration of the steel.

7 It is recommended that all control cable end fittings are inspected for degradation when access allows.

APPENDIX 31–1 Altimeters In Aircraft

1 Introduction

This Appendix supersedes Airworthiness Notice No. 12 Appendix No. 23 Issue 2 dated 6 November 1987 which was originally issued following incidents whereby altimeter pressure scales had become detached from altimeter pointers.

2 Background

- 2.1 Instances have occurred in flight whereby altimeter pressure setting scales have become detached from altimeter pointers when the pilot was attempting to set an appropriate QNH. This has resulted in large indicated altimeter errors.
- 2.2 Subsequent investigation has revealed that satisfactory operation of the altimeter depends on the barometric adjustment control knob being attached to the spindle so that no fore or aft play exists between the knob and instrument bezel. If such play exists, forward or rearward pressure on the knob may disengage the barometric adjustment scale from the altimeter pointer.
- 2.3 A number of altimeters of US manufacture are known to be prone to this particular defect. Included amongst these are the following:
- Aero Mechanism 8040, 8140, 8141, 8142, 8503 Series
 - Kollsman Altimeters,
 - Narco AR 800 Series,
 - Bendix 3252013 Series, and
 - United Instrument Altimeters.

3 Maintenance Considerations

- 3.1 The Federal Aviation Administration have issued Airworthiness Directive 86–05–02 which is applicable to a range of part numbers of United Instruments Altimeters that do not have encoding capabilities and were manufactured after 1 February 1985. The affected instruments were discovered to have a deficient locking clamp which resulted in a possible de-synchronisation of the barometric adjusting knob and altitude pointers.
- NOTE:** The CAA previously published Additional Airworthiness Directive (AAD) 006-02-87 which was cancelled on 28 September 2003.
- 3.2 It is strongly advised that before each flight the following checks are made:
- a) That rotation of the barometric adjustment control knob results in a movement of both the pressure setting scale and the altimeter pointers, and that forward and rearward pressure on the knob during rotation does not disengage the barometric adjustment scale from the altimeter pointers.
 - b) That the relevant altimeter pointer reading is compatible with the setting on the barometric adjustment scale.

APPENDIX 31-2 Vertical Speed Indicators on Imported Aircraft

1 Introduction

- 1.1 A recent incident on an imported light aircraft has shown the possible danger of the presentation of false information to the pilot due to reversed indication by the vertical speed indicator during a fast rate of descent.
- 1.2 United Kingdom approved instruments and instruments complying with EASA ETSO-C8d, JAA JSTO Specification C8d, or the United States TSO Specifications C8d or C8e, are fitted with stops to prevent such occurrences. It is not known whether other instruments, particularly those likely to be installed in imported aircraft of less than 5700 kg (12 500 lb) maximum weight, are similarly equipped.

2 Action

- 2.1 Before issue of the Airworthiness Certificate and subsequent reviews for continued airworthiness of an imported aircraft, it shall be established whether the vertical speed indicator is fitted with limit stops. This may be done by test or reference to the manufacturer.
- 2.2 If stops are not fitted, either the vertical speed indicator shall be replaced by an instrument that has stops, or alternatively the placard defined in paragraph 3 shall be fitted.

3 Placard

- 3.1 The following placard shall be fitted adjacent to a vertical speed indicator not fitted with stops:

‘This indicator is not fitted with limit stops and a rate of change of altitude in excess of the maximum calibration will cause indication in the reverse sense.’
- 3.2 The placard may, as a temporary measure, be typewritten on white card, but shall be replaced by a more permanent placard as soon as possible.

4 Record

A record of the action taken to comply with paragraph 2 above shall be made in the aircraft log book, quoting the serial number of the instrument.

APPENDIX 32–1 Brake And Anti-skid Systems

1 Introduction

This Appendix supersedes Airworthiness Notice No. 12 Appendix No. 8 Issue 2 dated 8 October 1974 which was originally issued to alert operators of the possibility of malfunction of anti-skid protection.

2 Background

Instances have occurred in which wheel brake systems incorporating antiskid protection have not functioned in a fully effective manner. Subsequently, in most instances, a fault has been discovered in the braking system which has prevented the brakes from operating efficiently on all wheels. Loss of efficiency can result from a variety of causes, e.g. incorrect assembly or failure of components in either an electrical or hydro/mechanical anti-skid system. In one instance, a cross connection of units in combination with a dormant fault contributed to an accident.

3 Airworthiness Considerations

- 3.1 Experience has shown that dormant faults which reduce the maximum energy absorption capability of the brakes can exist without being detected during normal energy stops. These only become apparent when the full effectiveness of the brakes is called into use, such as during a rejected take-off. In order, therefore, to guard against such troubles, it will be necessary to institute checks, at agreed periodic intervals and also after any disturbance or replacement of the brake or parts of the anti-skid system, to ensure that:
- a) the operation of each anti-skid sensor controls the brake on the wheel with which it is associated and
 - b) the operation of the whole braking system, including any anti-skid facility, is normal and satisfactory
- 3.2 If functional checks carried out in accordance with the relevant Maintenance Manuals would not achieve the objectives stated in 3.1 a) and b), the aircraft manufacturer should be consulted in order to agree suitable amendments to the Manuals to include tests which will verify the functional integrity of the system.
- 3.3 Operators having Maintenance Schedules/Programmes approved by the CAA should review these Schedules/Programmes, and if necessary, forward suitable amendments which will ensure that functional checks prescribed in the Schedule will cover the particular matters stated in 3.1 a) and b) and that any necessary cross references to the Maintenance Manual are amended or added.
- 3.4 In the event of difficulty in obtaining agreement with manufacturers, the CAA's Airworthiness Evaluation and Surveillance Department should be consulted.

APPENDIX 32-2 Tyre Maintenance And Reliability

1 Introduction

This Appendix supersedes Airworthiness Notice No. 12 Appendix No. 24 Issue 1 dated 26 May 1978 which was originally issued following a series of accidents and incidents caused by tyre failure.

2 Background

- 2.1 Multiple tyre failures have become more significant with the growth in aircraft size and weight and have resulted in serious accidents and incidents. Inadequate maintenance of tyres directly affects their performance and reliability. This is particularly so for the high pressure and/or high speed rating tyres, i.e. marked in excess of 160 mph, used on multi-wheel landing gear.

- 2.2 A marked reduction or loss of inflation of one tyre can, through over-deflection, result in the failure of other tyres on the same axle, or in a marked reduction in its own ability to carry the increased load after another tyre failure. The risk of such failures is likely to be greater during take-off when wheel loads and/or speeds are highest or during extended taxiing. Braking performance may also be affected to the extent that stopping distances are increased or the remaining effective brakes are over-heated. Tyre and wheel debris may damage hydraulic and anti-skid systems. One large aircraft was completely destroyed by fire and other serious fires have occurred. In some accidents, aircraft have left the runway during rejected take-offs associated with tyre problems during the take-off run.

3 Airworthiness Considerations

- 3.1 Adequate inflation pressure levels and leakage checks are necessary if adequate tyre performance is to be achieved. The maximum permissible inflation pressure improves a tyre's capability to sustain abnormal loads. Tyre pressures should be accurately checked on at least a daily basis, visual inspection is totally inadequate. Tyres should be inspected for external condition at every available opportunity bearing in mind that fitted stationary tyres cannot be entirely inspected.
- 3.2 Tyre removal criteria should be adhered to, and particular attention should be paid to tyres which have been over-deflected or underinflated or subjected to excessive brake heat. Wear limits and damage criteria can be found in tyre manufacturers' manuals and it should also be noted that very wet operational conditions could cause aquaplaning during landing.
- 3.3 The possibility of tyre carcass and tread failures which may damage structure, systems and engines and thus jeopardise safety, can be directly reduced by timely attention to, and adequate maintenance of, tyre and wheel assemblies.

4 Change of Tyre Specification

A recent survey of a Yak aircraft established that an American manufactured tyre had been fitted of a different size and ply rating to that recommended within the Parts catalogue. It should be noted that such changes to original specification must be supported by an approved modification.

5 Additional Information

Additional information can be found within CAAIP Leaflet 32-10 Tyres, and for specific tyre brands, most tyre manufacturers now publish information on their websites, detailing information on tyre care and general servicing instructions for aircraft tyres and tubes. The instructions are generally applicable, unless superseded by an individual aircraft maintenance manual, technical order or Airworthiness Directive.

Examples include:

<http://www.dunlopaircrafttyres.com/tyrecare/index.htm>
<http://www.goodyearaviation.com/tirecare.html>
<http://www.airmichelin.com/databook.html>
<http://ap.bridgestone.co.jp/candm/candm.html>

APPENDIX 33–1 Bonding Of Strobe Lights

1 Introduction

This Appendix supersedes Airworthiness Notice No. 12 Appendix No. 13 Issue 1 dated 27 January 1975 which was originally issued following an explosion and fire in a light aircraft prior to take-off.

2 Background

- 2.1 An incident of an explosion followed by a fire occurred on an American light aircraft, prior to take-off. This was caused by the ignition of spilt fuel by an electrical spark at an incorrectly bonded strobe light fitting. Following this incident Emergency Airworthiness Directive 74–20–11, covering Beech aircraft, was issued by the FAA. This was further superseded by AD 74-24-03. Since this hazard could develop during service on any aircraft to which strobe lights are fitted, the attention of owners and operators is drawn to the need to ensure that such strobe light units are correctly bonded, as outlined in paragraphs 3.1 – 3.3.
- 2.2 The recommendations of paragraph 3 are applicable to strobe lights which are fitted either during the initial build of the aircraft, or by subsequent modification action.

3 Airworthiness Considerations

- 3.1 For all aircraft, it is recommended that all strobe lights installed in areas which may be subjected to either spilt or vented fuel, or to high concentrations of fuel vapour (such as the wing tips or lower fuselage) should be inspected to ensure that a positive bond, not greater than 0.05 ohms resistance, is provided between the airframe and light housing. The inspection and any necessary rectification action should be carried out as soon as is practical, but in any event not later than the next schedule airframe maintenance inspection.
- 3.2 Wherever practical the bond should be a short, flexible, metal strap, attached between the light housing and the aircraft local structure, and with clean metal-to-metal contacts. After completion, the bonding attachments and surrounding areas should be adequately protected against corrosion.
- 3.3 Where the form of bonding described in paragraph 3.2 is impractical, a good metal-to-metal contact between the light housing and the aircraft structure must be ensured. This contact area must be clean and free from paint, dirt or corrosion.

APPENDIX 34–1 Maintenance of Radio Navigation Equipment Course and Alarm Signal Current Limits

1 Introduction

This Appendix supersedes Airworthiness Notice No. 12 Appendix No. 12 Issue 2 dated 22 August 1974 which was originally issued following an accident caused by an aircraft's signal current settings on the ILS Localiser and Glide Path systems being set too high.

2 Background

Following an aircraft accident it is understood that investigation of the ILS Localiser and Glide Path systems revealed that the signal current settings were set too high. This could result both in the course indicator being over-sensitive and in the flag warnings failing to appear in fault conditions.

3 Airworthiness Considerations

- 3.1 Engineers must ensure that the instructions contained in the relevant maintenance/overhaul manuals are complied with, particularly those applicable to course deviation and alarm current settings.
- 3.2 Prior to installation in an aircraft, engineers must ensure that the current settings of units are compatible with the particular aircraft system.
- 3.3 Any adjustment found necessary must only be carried out in a workshop where the necessary test equipment and maintenance/overhaul manuals are available and by persons appropriately approved.
- 3.4 Most ramp test equipment, whilst capable of checking alarm circuits for some gross failures, is inadequate for checking their operation in other important cases. In particular, it will not reveal whether current settings are such as to prejudice proper flag operation. The CAA is discussing with manufacturers the possibility of modifying such equipment, e.g. by making provision for the interruption of the tone sources so as to enable a check of the operation of alarm circuits of the installation to be made, and the outcome of these discussions would be the subject of manufacturers bulletins.
- 3.5 It is good practice, which the CAA will expect operators and maintenance organisations to implement, that all units incorporating adjustments for variable loads, whether in aircraft or held as spares, have a label indicating the loads for which the unit has been adjusted, fixed in a prominent position on the front of the unit. Aircraft using such units should have a similar label fixed to the unit mounting.

APPENDIX 34-2 MODE "S" Transponder ICAO 24-bit Aircraft Addresses

1 Introduction

This Appendix supersedes Airworthiness Notice No. 12, Appendix 67, Issue 4, dated 21 March 2005.

- 2 CAA have become aware of incorrect 24-bit addresses being installed/hard wired on individual aircraft. This has happened not only on first installation of a Mode S transponder but also when a modification has been made or following a change of State of Registration. Incorrect installation, such as setting the address to all zeros or inadvertent duplication of an address, can pose a risk to flight safety. In particular, the airborne collision avoidance system (ACAS) operates on the assumption that only a single, and therefore unique 24-bit aircraft address exists per airframe. The performance of ACAS can be seriously degraded and in some cases disabled if an incorrect or duplicate address is installed on an aircraft.
- 3 ICAO has recognised that the present management methodology of aircraft 24-bit addresses presents a genuine safety hazard that needs to be addressed and suitably

mitigated in any system that is to make use of the Mode S address. CAA have issued AIC 94/2004 (yellow 151) dated 14 October 2004 in order to make the operating community aware of this issue. This Appendix to Leaflet B-180 is published to make the maintenance community similarly aware as it affects them.

4 In order to ensure that the 24-bit Mode S address is installed correctly at the time of initial CAA certificate of airworthiness issue, as well as throughout the in-service life of the aircraft and at the time it leaves the UK register, the following should be accomplished:

- a) A positive check that the correct Mode S address is assigned for each transponder installed on the aircraft.
- b) The correct Mode S address is periodically confirmed and recorded for each transponder installed on the aircraft, via a field test set at an appropriate maintenance opportunity (not to exceed a 2 year periodicity). This task should be incorporated into the Approved Maintenance Schedule or Programme.

NOTE: Contact details to obtain an allocated ICAO 24-bit address may be obtained from the Mode S homepage on the Directorate of Airspace Policy website via www.caa.co.uk.

- c) Ensure whenever the aircraft is subject to modification that the Mode S address has not been changed.
- d) The UK assigned Mode S address is removed when the aircraft leaves the UK register.

5 Operators are requested to review their documented procedures and update them, as appropriate, to ensure the above points are addressed. These procedures should also include a method to record that the applicable actions have been accomplished.

6 Reference should also be made to CAAIP Leaflet B-180 Appendix 34-3 which contains advice on testing criteria for Transponders.

NOTE: With the introduction of Mode S Elementary and Enhanced Surveillance functionality, within the transponder, it is envisaged that additional testing of the transponder will be required on a periodic basis (not to exceed 2 years). Notification of revised testing requirements will be included in a future issue of CAAIP Leaflet B-180 Appendix 34-3.

APPENDIX 34-3 ATC Transponders and Traffic Alert and Collision Avoidance Systems (TCAS) Ground Testing

1 Introduction

This Appendix supersedes Airworthiness Notice No. 12 Appendix 69, Issue 1, dated 28 September 2005.

This Leaflet is to provide general guidance material to aircraft maintenance organisations and maintenance personnel relating to ATC Transponder and Traffic Alert and Collision Avoidance Systems (TCAS). It includes information on the TCAS system together with precautions to be considered when ground testing ATC Transponders in order to minimise the possibility of causing nuisance advisory warnings on TCAS equipped aircraft.

NOTE: In Europe TCAS is often referred to as Airborne Collision Avoidance System (ACAS).

2 General

A number of aircraft operating within airspace regulated by the United Kingdom are now equipped with TCAS. This equipment provides flight deck crew with an independent back-up to visual search and the ATC system by alerting them to potential collision hazards. In the case of the more sophisticated systems which predominate in number, the equipment provides advice to the flight deck crew on how best to manoeuvre so that adequate separation may be maintained or achieved between potentially conflicting aircraft.

3 System Description and Operation – TCAS II

- 3.1 TCAS comprises a dedicated computer unit with associated aerials. Visual and voice advisories are provided for the flight deck crew.
- 3.2 The TCAS computer requires the presence of a mode S transponder which provides a data link between TCAS equipped aircraft. Sensor inputs to TCAS include radio height and pressure altitude.
- 3.3 TCAS can provide two distinct forms of advisory information to the flight deck crew, Traffic Advisory (TA), and Resolution Advisory (RA).
- a) Traffic Advisory (TA), is aural and visual information provided in the cockpit to advise the flight deck crew as to the position of a potential threat aircraft.
 - b) Resolution Advisory (RA), is aural and visual information provided in the cockpit to advise the flight deck crew that a particular manoeuvre should, or should not, be performed to maintain safe separation from a threat aircraft.
- NOTE:** Resolution Advisories can not be produced if a potential threat aircraft does not provide altitude information.
- 3.4 TCAS equipped aircraft operate by interrogating the mode S or mode A/C transponders in proximate aircraft. The replies from mode S and mode C transponders are tracked in range, bearing and altitude. This data is passed on to the system logic for TA and RA processing and display.
- 3.5 Mode A/C transponders which are not equipped with an altitude encoder or when the altitude reporting is switched off, reply with no data in the altitude field, therefore, the TCAS will track in range and bearing only. This information is passed to the collision avoidance logic for TA detection and display.

4 Testing Considerations

- 4.1 Recognising that airborne TCAS aircraft operate by interrogating operational transponders, it is apparent that they will elicit replies from transponder equipped aircraft on the ground if they are in range and the equipment switched on.
- 4.2 This, therefore, presents the possibility that a ground operated transponder may trigger a nuisance advisory on a TCAS equipped aircraft operating in the close vicinity. If the ground target is providing altitude data the TCAS logic should declare the aircraft to be on the ground and ought not to generate an advisory.
- 4.3 If no altitude data is provided the TCAS will generate a TA if the threat criteria are met. If the ground is providing altitude data other than surface altitude, as may happen with a defective altitude encoder, or if a test pressure is being applied to the altitude encoder, the TCAS may generate both a TA and a RA if the threat criteria are met.

- 4.4 Maintenance organisations and personnel who are involved in the ground testing of transponders and TCAS equipment are requested to establish procedures and take precautions to ensure that the risks of causing nuisance advisories are recognised and kept to a minimum.
- 4.5 It is considered that nuisance advisories may be caused to any TCAS equipped aircraft flying in the vicinity of transponders which are being tested, this may also include aircraft passing overhead at medium altitudes. The problem may be more noticeable where ground testing of transponders takes place at airfields located beneath Terminal Control Areas or in the vicinity of Control Areas and Zones where air traffic movements are likely to be numerous.
- 4.6 The following advice is provided to minimise the possibility of causing nuisance advisories to TCAS equipped aircraft when ground testing transponders and/or TCAS:
- When not required ensure that transponders are selected to 'OFF' or 'Standby'.
 - For transponders under test, when equipped for altitude reporting, set the control unit to 'Mode A/C' and select Altitude Reporting 'ON'.
 - Where possible, carry out testing inside a hangar to take advantage of any shielding properties it may provide.
 - Always use the antenna transmission absorption covers when these are provided with the test set.
 - When testing mode C operation which require the altitude to be increased, radiate directly into the ramp test set via the prescribed attenuator.
 - In between test parameters, select the transponder to the standby mode.
 - The simulation of TCAS operation by the radiation from an antenna located on, or remotely based from a workshop, is not permitted.

NOTES: 1) The FAA have advised their staff of operational problems resulting in nuisance advisories caused by ground based transponders installed on hangars for the purpose of testing TCAS installations. Maintenance organisations are reminded that all UK aeronautical radio stations are required to be licensed by the Department of Trade and Industry and the CAA.

2) Air Traffic Control Units may be advised when testing is to be carried out if it is considered that there is a possibility of nuisance advisories being caused by the activity due to its proximity to operational runways.

APPENDIX 35–1 Oxygen Fire Risk

1 Introduction

This Appendix supersedes Airworthiness Notice No. 12 Appendix No. 3 Issue 1 dated 1 March 1973 which was originally issued to warn operators of the damage which can be caused when fire is fed by the aircraft's oxygen system.

2 Background

- 2.1 Serious fire damage to aircraft has been caused where fires (which would probably otherwise have been insignificant) have been fed by oxygen from the aircraft's piped oxygen system. In some cases an oxygen leak contributed to the outbreak of fire, in others the oxygen was liberated by the fire which as a result then became much more severe.

- 2.2 Although the increased flammability and heat of combustion of many materials in the presence of oxygen is well known, it appears that due regard for this fact is not always paid in the design of aircraft, particularly in the consideration of minor modifications after original manufacture.

3 Airworthiness Considerations

Precautions should be taken to ensure that an oxygen leak will not create a fire hazard where none previously existed and that a minor overheat or an electrical fire condition cannot damage the oxygen system, thus promoting far more serious consequences. Therefore, leak checks should be carried out after any disturbance of an oxygen system.

APPENDIX 35–2 Passenger And Crew Oxygen Systems

1 Introduction

This Appendix supersedes Airworthiness Notice No. 12 Appendix No. 50 Issue 1 dated 16 March 1993 which was originally issued following an increasing number of incidents in which the passenger/crew oxygen systems failed.

2 Background

- 2.1 The CAA has noted an increasing number of occurrences relating to failures of passenger/crew oxygen systems. In a significant proportion of the cases reported, the failures were attributed to installation errors following maintenance, operation or test. These occurrences were mostly in connection with, but not confined to, passengers/crew oxygen automatic drop out systems.
- 2.2 Due to the nature of the design of the automatic drop out systems, an installation error may lay dormant and undetected until the system is used (possibly in an emergency). Faulty installation has, on a number of occasions, subsequently led to a functional failure of part or all of a system, leading to an obvious lowering of safety levels. On a number of occasions, it has been reported that supply pipes have been crushed and rendered inoperative by faulty installation.

3 Maintenance Considerations

- 3.1 Operators should ensure that staff who may need to maintain, test or re-install oxygen systems, especially the more elaborate passenger/crew oxygen drop out systems, are adequately trained for the task and are retrained as necessary to ensure retention of their competency levels.
- 3.2 Operators should ensure that maintenance schedules adequately address the need to assess the functional integrity of these otherwise mostly dormant systems. Additionally, test and installation instructions to maintenance staff and crew members (where necessary) should be reviewed to ensure that such instructions are adequate and unambiguous. The instructions should emphasise the need to ensure that following functional testing or maintenance, all functional inhibiting devices are removed.

- 3.3 In the case of portable oxygen systems in particular, care should be taken to ensure that not only is the bottle addressed during routine maintenance and check (contents and pressure testing etc.) but the condition of masks and piping should be continuously monitored during service, possibly by cabin staff as well as maintenance staff. Consideration should be given to invoking pre-flight checks by cabin staff where appropriate.

APPENDIX 51–2 Primary Structural Fasteners Made in H-11 Steel

1 Introduction

This Appendix supersedes Airworthiness Notice No. 12 Appendix No. 35 Issue 1 dated 10 December 1986 which was issued following an abnormally high failure rate of H-11 steel bolts.

2 Background

An abnormally high failure rate in service of H–11 steel bolts has been reported from the USA. Such failures are mainly caused by stress corrosion. H–11 is a 5% chromium molybdenum tool steel to specifications such as BS 4659; BH–11; DTD 5222; AMS 6488; AISI H–11 Modified. It is heat-treatable to tensile strength above 1400Mpa (over 200,000 lbf/in²) with good strength retention at high temperature. Typical applications are specialised bolts in engine, nacelle, flap track and undercarriage mounting structures and H–11 is also offered as a material in some standard ranges of fasteners.

3 Airworthiness Considerations

- 3.1 Aircraft manufacturers are asked to review their current and projected designs and take any necessary action to avoid the use of H–11 fasteners wherever practicable, particularly in locations where any fastener is:
- a) in a tension application,
 - b) a single load path,
 - c) exposed to phosphate-ester hydraulic fluid above 120°C (250°F),
 - d) exposed to exhaust gases,
 - e) subject to weathering.
- 3.2 When failures have occurred in service, the remaining H–11 fasteners should be replaced by a fleet campaign rather than on an attrition basis. The aircraft manufacturer should be consulted regarding replacement fasteners of a suitable alternative material.
- 3.3 Owners and operators are asked to review their aircraft fleets in respect of such fasteners to ensure:
- a) adequate maintenance of corrosion protection schemes,
 - b) implementation of manufacturer’s SB on the subject,
 - c) correct torque tightening (without over-torque) of such fasteners on re-installation.

APPENDIX 51–3 Corrosion Inhibiting (Temporary Protective) Compounds

1 Introduction

This Appendix supersedes Airworthiness Notice No. 12 Appendix No. 46 Issue 1 dated 18 March 1991 which was originally issued following a review of corrosion inhibiting compounds.

2 Background

In conjunction with the international activity on ageing aircraft, the CAA has been reviewing the nature of corrosion inhibiting (temporary protective) compounds and their use in the transport aircraft operating industry.

3 Design Considerations

- 3.1 Overall it has become clear that operators may be using such compounds that are different from those recommended or approved by the manufacturer of the aircraft they operate. Operators are reminded that in such circumstances it is their responsibility to ascertain, and technically justify, the fitness for purpose of the compound they use in their particular applications. Furthermore, adequate procedures should be in place to ensure that the material procured consistently meets its specification.
- 3.2 On this latter point a local authority trading standards department has advised the CAA that in recent years one product of intermediate viscosity has been supplied to the industry with its viscosity clearly above specification maxima.
- 3.3 One consequence of too high viscosity is the lack of penetrating capability which could lead to areas of structure, particularly mating surfaces, remaining unprotected. Operators are advised to check that their stocks of such material are of the appropriate viscosity. Should they believe that they have used such non-conforming materials on an aircraft, the area of application should be cleaned and reprotected with appropriate conforming material, at the next maintenance opportunity.

APPENDIX 51–4 Lock-Bolt Failures

1 Introduction

This Appendix supersedes Airworthiness Notice No. 12 Appendix No. 26 Issue 1 dated 15 January 1981 which was originally issued as a result of problems encountered with lock bolts.

2 Background

- 2.1 An airframe manufacturer has experienced a problem whilst inserting steel swage locking pins (lock-bolts).
- 2.2 When auto setting ¼" dia. lock-bolts (U.S.A. NAS 1468) in a rear wing spar assembly some failures of the lock-bolt occurred on the first locking ring groove instead of at the break groove. Other ¼" dia. lock-bolts removed from the same assembly were

found to be 'necked' with cracking evident in the first locking ring groove. This cracking is not visible without removing the bolt but may result ultimately in the loss of the locking collar.

- 2.3 Subsequent investigations revealed that defective lock-bolts have a carburised surface with a hardness above the upper limit of the U.S.A. Procurement Specification (NAS 1413).

3 Airworthiness Considerations

Manufacturers using this type of fastener are recommended to check that their stocks are within specification, with particular reference to hardness values. Owners and Operators of aircraft are advised to check such fasteners for security of collar on an opportunity basis.

APPENDIX 51-5 Control of Precision Cutting Tools

1 Introduction

This Appendix supersedes Airworthiness Notice No. 12 Appendix No. 49 Issue 1 dated 9 November 1992 which was originally issued following incidents during airframe manufacture which highlighted the ease with which incorrect countersink angles and knife edge holes may be cut when adequate controls are not in place.

2 Background

In the latest incident, a series of 90° countersinks were cut when 100° was specified. This was not revealed during fastener installation or the subsequent inspection of the fasteners, as the countersinks were covered by the fastener heads.

3 Design Considerations

- 3.1 Manufacturers and maintenance organisations are reminded of the need to ensure that adequate procedures are in place to control the issue and use of precision cutting tools and the installation of correct fasteners.
- 3.2 Incorrectly cut countersinks can cause a severe decrease in the strength of a joint leading to a serious reduction in airworthiness and to the need for costly repair or replacement.

APPENDIX 51-6 Self-locking Fasteners

1 Introduction

This Appendix supersedes Airworthiness Notice No.12 Appendix No. 17 Issue 3 dated 16 March 1998.

2 Background

A recent incident investigation concluded that the cause was the loss of a number of bolts, used to secure a helicopter tail rotor drive shaft fairing, and that the bolts were lost because the self-locking function of the associated stiffnuts had become ineffective.

3 Airworthiness Considerations

Previous issues of Airworthiness Notice No. 12 Appendix 17 highlighted that there have been a number of incidents concerning the use of self-locking fasteners in helicopter control systems. These incidents arose when self-locking fasteners on control system linkages had become detached, allowing the control system to separate. The scope of this Appendix 51-6 has now been broadened to further emphasise that the hazards associated with self-locking fasteners used in control systems are also applicable to aircraft access panels on both rotary and fixed wing aircraft.

The disturbance of fasteners to facilitate maintenance tasks may result in degradation of the effectiveness of the friction component. Where the aircraft manufacturer permits the re-use of self-locking fasteners, maintenance personnel are reminded that careful attention must be given to their security, and the effectiveness of the self-locking function.

In every case the aircraft manufacturers' guidance should be adhered to in relation to the use and re-use of self-locking fasteners. Such fasteners must not be re-used unless the user is satisfied that the self-locking characteristics have not deteriorated to a point where there is an ineffective friction element. Where no guidance is available from the aircraft manufacturer, it is recommended that the guidance given in CAAIP (CAP 562) Leaflet 2-5 paragraph 8, including the advice not to re-use certain fasteners, should be followed.

APPENDIX 51-7 Foreign Objects and Loose Articles – Danger of Jamming

1 Introduction

This Appendix shows information previously published in Airworthiness Notice No. 12 Appendix 7 Issue 6 dated 2 April 2004.

2 Background

Jamming of aircraft flight control systems by foreign objects and loose articles such as those identified below continues to be a major threat to aircraft safety. Approved Organisations, Aircraft Owners and Licensed Aircraft Engineers must remain alert to the hazards of entrapment of such items and ensure that adequate precautions are taken to prevent items falling into or being left in critical areas. Good design, high standards of cleanliness and the implementation of standard practices can reduce the risks of such incidents. However the awareness of personnel involved in all aspects of aircraft operation is one of the most important elements in preventing such potentially dangerous incidents.

3 Manufacturing, Airworthiness and Operational Considerations

3.1 As the presence of foreign objects and loose articles can cause jamming or restriction of engine and flight control systems, organisations involved in the manufacture, operation and maintenance of aircraft, should establish standard practices to address foreign object and loose article control. Such practices should require personnel to check that all equipment, tools, rags or any loose objects/articles, which could impede the free movement and safe operation of a system(s), have been removed and that the system(s) and installation in the work area are clean and unobstructed.

3.2 In particular maintenance personnel are the front line of defence against such problems. As such they should remain vigilant of the need to remove foreign objects and loose articles during and after any scheduled or non-scheduled maintenance. Consideration should also be given to the potential to introduce loose articles into control systems from adjoining structure e.g. loose or incorrectly torqued fasteners. While a structure may remain safe with one fastener missing, the aircraft safety may be severely compromised if that fastener jams a control system.

NOTE: The Duplicate Inspection is intended to ensure the correct operation and assembly of controls, it will not prevent loose articles or foreign objects from becoming a hazard to their continued safe operation.

3.3 Some of the reported incidents:

- Throttle movement found to be stiff due to a broken plastic spoon, lodged between throttle levers and adjacent components in throttle pedestal.
- A bolt lodged between a flying control hydraulic-booster jack and its chassis.
- Hydraulic fluid top-up cans and meal trays fouling primary control runs.
- A spare control rod left in a fin by the manufacturer, causing intermittent jamming of rudder and not found during twelve months of operation.
- A nut left on a control chain adjacent to the sprocket, causing the chain to fail and jamming one flap surface.
- A ring spanner which had remained undiscovered for two and a half years in a wing bay which had been opened several times for control systems inspection.
- An incorrectly fitted screw on a fin leading edge which rolled across the top of the fin and jammed the elevator during the take-off climb.
- A rudder pedal control jammed during taxi checks due to a coat hanger in a footwell.
- The AAIB investigation of an accident involving a jammed elevator, found numerous foreign objects which potentially may have restricted control system movement.
- An AAIB investigation of a fatal accident to a light aeroplane, revealed a small screwdriver had jammed the elevators such that they could not be moved beyond neutral in a nose-up direction.

APPENDIX 56-1 Aircraft Windshields and Transparencies

1 Introduction

This Appendix supersedes Airworthiness Notice No. 12 Appendix 54 Issue 1 dated 7 November 1997 which was issued as a result of a General Aviation accident review.

2 Background

The CAA wishes to draw attention to the importance of maintaining the visibility of windshields and transparencies to ensure that a clear and undistorted view is provided for flight crew.

3 Operational and Airworthiness Considerations

Operators and maintenance organisations are reminded that the optical standard and the standard of cleanliness of cockpit windshields and transparencies can have a direct effect on the flying of the aircraft especially in conditions of poor visibility. A hazy screen blurs the details, reduces black to grey and dims outlines. Dirt or slight scratching scatters the light and may make it impossible for the pilot to see against the sun.

Section 7 of the Light Aircraft Maintenance Schedule (LAMS) requires the inspection of windscreens at Check A intervals, with a further inspection of all windows at 50 hour, 150 hour and Annual check periods. Where other maintenance schedules do not refer to this subject, action should be taken to revise the schedule as appropriate.

APPENDIX 70–3 Effects of Chloride Based Materials on Stainless Steel and Titanium

1 Introduction

This Appendix supersedes Airworthiness Notice No. 12 Appendix No. 41 Issue 1 dated 18 August 1989 which was issued following premature failure of stainless steel pipes.

2 Background

- 2.1 Premature failure of stainless steel pipes has occurred in engines due to the unauthorised applications of chloride based materials, such as Neoprene tube and glass fibre tape, used as wrappings to protect pipes from chafing against adjacent parts. Whilst the desire to minimise wear due to fretting is quite reasonable, the need to ensure that the correct materials are used cannot be over-emphasised.
- 2.2 Chloride based materials break down with heat (temperatures above 150°C) to produce corrosive salts which will attack stainless steel and titanium components, resulting in premature failure.
- 2.3 It is possible that smears of chloride material may be left on components which have been touched by PVC (Plasticised Polyvinyl Chloride) sheeting while covered over by, or packed in, such material.

3 Airworthiness Considerations

Operators and Maintenance Organisations are reminded of the need to refer to the approved publications and use only the equipment and materials specified therein.

APPENDIX 72-1 Air Intake Filters

1 Introduction

This Appendix supersedes Airworthiness Notice No. 12 Appendix No. 31 Issue 1 dated 1 April 1985 which was issued following a series of forced-landings involving piston-engined aircraft attributable to collapsed air intake filters.

2 Background

- 2.1 Forced-landings have occurred involving piston-engined aircraft which were directly attributable to collapsed air intake filters obstructing the carburettor. In one case only a fortunate combination of circumstances enabled the pilot to avoid a potentially serious accident.
- 2.2 Investigation suggests that the maintenance applied to the air intake filters on piston-engined light aircraft may not always be adequate. The LAMS Schedules concern themselves with the cleanliness and condition of air intake filters, but under the definition of 'inspect', imply that this can be done in situ and as viewed externally. Individually approved maintenance schedules are generally similar in this respect.

3 Airworthiness Considerations

- 3.1 In practice it is apparent that for a typical air intake filter installation:
 - a) Visual inspection of the downstream face is usually not possible in situ. It is this face which may show the first signs of collapse.
 - b) Varying degrees of dismantling may be necessary to gain access to it.
 - c) In nearly all cases it must be removed for cleaning.
 - d) Methods of cleaning vary and some methods may not be effective for all types of filter.
- 3.2 When completing scheduled maintenance inspections, engineers and pilots who may accomplish 50-hour checks on Private Category aircraft maintained to the LAMS Schedules must be satisfied that air intake filters are clean and fully serviceable. If visual inspection of both faces of the filter is not readily possible, consideration must be given to gaining access sufficiently often to ensure continued serviceability. Reference should be made to the manufacturers instructions whenever air filter inspections are carried out.

APPENDIX 76–1 Single Path Control Systems

1 Introduction

This Appendix supersedes Airworthiness Notice No. 12 Appendix No. 20 Issue 1 dated 31 August 1977 which was originally issued following an incident which occurred as a result of failure of a carburettor mixture indicator.

2 Background

An incident which could easily have been a serious accident occurred because the single strand inner core of a flexible push pull mixture control failed at the mixture control lever on the carburettor and the lever subsequently vibrated into the lean position, resulting in a loss of engine power during take-off.

3 Design Considerations

Designers embodying such controls should consider the consequence of failure and the practicability of mitigating any serious effect by the provision of a friction device or by spring biasing the part to be operated by such a control to the safest position.

INTENTIONALLY LEFT BLANK

Leaflet B-190 Carbon Monoxide Contamination

1 Introduction

- 1.1 This Leaflet describes the nature and effects of carbon monoxide (CO) and outlines the main causes of this type of contamination. It gives only general guidance on the inspections, tests and repairs which should be carried out in order to minimise the dangers of such contamination to crew and passengers and must, therefore, be read in conjunction with the relevant aircraft Maintenance Manuals.
- 1.2 The harmful effects of contaminants in the air breathed by crew and passengers are recognised in British Civil Airworthiness Requirements (BCAR). It is stipulated in the Requirements that CO should not be present in occupied compartments in quantities exceeding 50 parts/million by volume, for any period exceeding five minutes: maximum allowable concentrations are also prescribed for other noxious substances such as fuel, oil, de-icing and hydraulic fluids, fire extinguishing agents and the fumes given off by other materials when they are heated. CAP 747 Mandatory Requirements for Airworthiness Generic Requirement (GR) No. 11 deal specifically with CO contamination.

2 The Nature and Effects of Carbon Monoxide

- 2.1 Carbon monoxide is a gas which is colourless, odourless and tasteless and is therefore impossible to detect by the senses. It is a product of the incomplete combustion of carbonaceous materials and is found in varying amounts in the smoke and fumes emanating from the exhaust systems of aircraft engines and combustion heaters.
- 2.2 If a person breathes air contaminated by CO, the CO will combine with the haemoglobin in the blood and cause oxygen starvation in the body and brain, thus reducing the person's normal ability to reason and make decisions. Exposure to even small amounts of CO over a period of several hours can be as dangerous as a short exposure to much larger amounts. At altitude, with a smaller quantity of oxygen in the atmosphere, the susceptibility to CO poisoning is correspondingly increased.
- 2.3 The presence of CO in the air may often be assumed from the smell of exhaust fumes and from the onset of symptoms such as mild tiredness, a feeling of warmth and tightness across the forehead. These symptoms cannot, however, be relied upon to give adequate warning of CO contamination and a person's judgement may become impaired by levels of CO in the blood lower than that at which the symptoms normally appear.

3 Causes of Carbon Monoxide Contamination

Carbon monoxide may enter the interior of an aircraft in a number of ways. Defective cabin heating systems of the type which use the engine exhaust pipe as the heat source and combustion heaters which are independent of the aircraft engines, may introduce CO directly into the fuselage through the cabin heater outlets, while the engine and heater exhaust gases may enter from the outside, either on the ground or during flight. Exhaust gas leaking from any part of the engine exhaust system through cracks, or faulty slip joints, gaskets or mufflers, can find its way into the aircraft through ineffectively sealed bulkheads, access panels or skin joints and in some cases,

particularly during starting, ground-running and taxiing, the gas discharged from the engine exhaust pipes may enter through open windows or cabin fresh-air intakes. During flight, any poorly sealed doors or windows can result in reduced cabin pressure, encouraging exhaust gas to be drawn into the cabin through the lower fuselage or wing roots.

4 Routine Inspections

- 4.1 The physical inspection of all exhaust system and cabin heating components, of bulkheads and of access panels in the fuselage, should be carried out at the intervals prescribed in the Maintenance Schedule.
- 4.2 All parts of the engine exhaust system should be inspected for security, warping, dents, cracks and evidence of gas leakage (i.e. overheating or smoke traces) particularly at clips, slip-joints, clamps, expansion joints and heater jackets. Repair or replacement should be carried out in accordance with the manufacturer's instructions.
- 4.3 Exhaust pipes under heater jackets should be inspected very carefully at the prescribed intervals and whenever CO contamination is suspected. In some cases the heater jacket is detachable and can be completely removed to enable a thorough visual inspection of the exhaust pipe for signs of gas leakage. In cases where the jacket is integral with the exhaust pipe, it is recommended that a pressure test should be carried out by blanking the outlet from the heater jacket and applying air pressure, via a suitable non-return valve, through the inlet; there should be no leakage when the air supply is turned off.
NOTE: The maximum test pressure prescribed in the appropriate Maintenance Manual should not be exceeded, since excessive pressure may damage the jacket and increase the likelihood of crack propagation.
- 4.4 The procedures for ensuring the serviceability of combustion heaters are outlined in CAP 747 GR No. 11 and detailed in the appropriate manufacturer's and aircraft manuals. The heater exhaust system should be inspected for the defects listed in paragraph 4.2 and the ducting carrying the heated fresh air from the combustion heater to the cabin should be examined for signs of exhaust contamination. Overhauls of heaters should normally be carried out at the prescribed intervals (normally not exceeding two years). In some instances the combustion chambers are required to be pressure-tested at half the overhaul life.
- 4.5 Engine bulkheads and the bulkheads isolating combustion heaters, are designed to prevent the transmission of flame, heat or gas to the airframe structure or cabin. Any joins or openings for controls, pipes, or fittings, are sealed with heat-resistant material. All bulkheads should be examined for cracks, damage, ineffective sealing and signs of smoke or overheating.
- 4.6 Access panels, particularly those fitted in the underside of the fuselage or giving direct access to the cabin, are generally sealed with a rubber or elastomeric gasket between the panel and the fuselage skin. These gaskets prevent the entry of exhaust gases into the fuselage and are thus important in preventing CO contamination. The fasteners and gaskets of access panels should be examined for security and effectiveness whenever the panels are removed.
- 4.7 Lap joints and butt joints in the exterior skin of an aircraft are often sealed by the use of a liquid sealant when the skins are riveted during manufacture. When modifications or skin repairs are carried out the same methods should be used to prevent the entry of exhaust gas and an inspection should be made to ensure that the sealing is effective.

- 4.8 Cabin windows and windscreens are usually secured to the metallic structure of the aircraft by means of rubber sealing channels or strips. Poor sealing of these glazed panels could allow exhaust gas into the fuselage and the seals should be examined for security, condition and fit.
- 4.9 On twin-engined aircraft, exhaust gas may enter the wheel wells or flap shrouds and flow along the leading and trailing edges of the wings into the fuselage. The sealing in these areas and the landing gear doors, should be checked for effectiveness.

5 Tests for CO Contamination

- 5.1 When doubt exists as to the extent of contamination of the air in the crew or passenger compartments, a test should be carried out to determine the CO concentration. This test is usually carried out by a sampling process, detection being based on the colour reaction of CO with iodine pentoxide, selenium dioxide and fuming sulphuric acid. A typical apparatus and test are described in paragraph 5.2.

5.2 Test Apparatus

- 5.2.1 The apparatus usually consists of a hand-operated bellows, which is used to draw a specified volume of air through a sampling tube, the presence of CO being indicated by the staining of crystals in the indicating portion of the tube.
- 5.2.2 The sampling tube is a sealed glass capsule containing crystals which are white on one side of a datum line and pigmented with the reagent on the other side of the datum line. The white (indicating) part of the tube has two scales marked on the outside of the glass, one graduated for small CO concentrations and the other graduated for large CO concentrations, the units used generally being parts per million (ppm).
- 5.2.3 When carrying out a test, the ends of a sampling tube should be broken to expose the chemicals and the indicating end of the tube should be inserted in the air intake opening of the bellows assembly. The bellows should then be fully compressed and when released will expand under internal spring pressure to draw a specified quantity of air through the sampling tube. The number of times the bellows is operated depends on which scale is being used and this information should be obtained from the manufacturer's published literature. The presence of CO in the air drawn through the sampling tube will result in a green-brown staining of the indicator crystals, the extent of staining depending on the quantity of CO in the sample. The CO concentration can then be read directly from the appropriate scale, at the dividing line between the white and stained crystals.
- 5.2.4 Tests should be carried out with the engine(s) running and the cabin heater turned on, both on the ground and during flight, to take account of varying conditions of airflow around the aircraft.

6 Repair or Replacement of Parts

- 6.1 The repair or replacement of parts may have to be carried out if it is discovered that CO is entering the crew or passenger compartments in quantities sufficient to cause concern. The procedures relevant to particular components are outlined in paragraphs 6.2 to 6.6.

6.2 Exhaust Pipes and Heater Jackets

Renewal of damaged parts is generally preferable to repair and new gaskets or seals should always be fitted when replacing a component. Damage may often be repaired by welding, but when making such repairs it is important to comply with any specific instructions which may be contained in the relevant Maintenance Manual. Extreme care should be taken to maintain the original contour, since any disruption to the smooth flow of exhaust gas will result in a hot spot and lead to early failure at that point. It is also important to ensure that the materials used in a repair are the same as, or compatible with, the original material. Pre-heating may be necessary in some cases to prevent cracking and it may be recommended that, after welding, parts are heat-treated in accordance with a prescribed procedure or normalised to reduce grain size in the weld area. Pressure tests are generally required after welding operations.

6.3 Combustion Heaters

Combustion heaters should be maintained in accordance with an approved Maintenance Schedule, using only those procedures detailed in the relevant manuals produced by the aircraft manufacturer or the equipment manufacturer; any repairs or replacements which become necessary should be carried out in accordance with these instructions. If burning or traces of smoke are found in the cabin heater ducting the cause should be ascertained and the defective parts repaired or renewed as necessary. Damage to the cabin heater ducting, which is generally made from glass-cloth, nylon or silicone rubber and supported by a steel coil, is generally not repairable and the affected parts should be renewed.

6.4 Bulkheads

Cracked or otherwise damaged bulkheads should be repaired in accordance with the procedures laid down in the relevant Repair Manual and using only those materials specified for the particular repair. At the same time that repairs are carried out, all sealing material applied to the bulkhead should be examined for condition and effectiveness and renewed as necessary.

6.5 Access Panels

Access panels may become distorted with use and allow contaminated air to enter the aircraft. If a panel is found to be in this condition it may sometimes be repaired by, for example, adding a stiffener, or by adjustment or replacement of the fasteners, but replacement with a new panel may often be necessary. Damaged or incorrectly fitted rubbing strips or seals in an access panel aperture may also result in air leakage and should be repaired or renewed in accordance with the relevant manuals.

6.6 Doors and Windows

Poorly fitting or ineffectively sealed cabin doors and windows on aircraft can allow the entry of contaminated air. Although hinges and locks are adjusted during installation to provide a good aerodynamic fit and to ensure the safety of the locking mechanisms, the effects of air loads and wear may result in the need for re-adjustment from time to time and this should be carried out strictly in accordance with the manufacturer's instructions. Door seals may be of the solid or inflatable type and are usually attached to the door surround with a suitable adhesive; if damaged or loose they may usually be repaired, but special procedures and materials are usually required. Information concerning the repair or replacement of door and window seals should be obtained from the relevant Maintenance Manual.

Leaflet B-200 Compact Disc – Read Only Memory (CD-ROM) Technical Library

(Formerly entitled “Airworthiness Data Supplied and Held in Electronic Format”)

1 Introduction

- 1.1 The availability of information as digital libraries providing information, guidance and Airworthiness data in electronic format is now widespread throughout the aviation industry. Airworthiness data (e.g. (EC) Regulation 2042/2003, Annex II, Part 145, 145.45) published in this format potentially offers the user simplified search and access functions when compared with Airworthiness data produced in the more traditional formats. Increasingly the CAA is being asked if it is permissible to accept commercially produced electronic libraries as an alternative to the more traditional 'hard copy' or Microform (Microfiche) manuals.
- 1.2 Commercial library systems provide a useful service in consolidating all related information into digital format with regular updating by electronic means. Users therefore have the benefit of a comprehensive information source without the difficulty of incorporating frequent amendments.
- 1.3 The purpose of this Leaflet is to provide guidance on the acceptance of Airworthiness data provided in electronic format. When promulgated by either the appropriate Type Certificate holder, Design Organisation or Airworthiness Authority, in any format, it is referred to as 'Primary Source'. When promulgated by a third party it is referred to as 'Secondary Source'.
- 1.4 It should be borne in mind that, in respect of CAA Approval, firstly, access to the Airworthiness data is required by the requirement for gaining and maintaining that approval. Secondly, the CAA must be satisfied that the person (or organisation) which the CAA has licensed or approved to make reports is qualified to do so, and remains so. The need for that person or organisation to have access to the up to date appropriate Airworthiness data is therefore essential.

2 Use of Primary Source Airworthiness Data

Primary Source material need not necessarily be in hard copy format as the use of computer recorded Airworthiness data is now recognised in many areas of the law. Hence there appears to be no reason for not accepting it in aviation. The source of information rather than its format will, therefore, be the CAA's primary concern.

3 Use of Secondary Source Airworthiness Data

- 3.1 In all cases, an organisation choosing to use Secondary Source Airworthiness data will be responsible for ensuring that the source of the Airworthiness data will provide a level of accuracy equal to that provided by Primary Source Airworthiness data. Furthermore, the revision frequency will need to be such that it reflects that of the Primary Source Airworthiness data. In entering into an arrangement based on Secondary Source Airworthiness data, users will need to determine that the organisation providing the Airworthiness data is legally entitled to do so.

- 3.2 When selecting a supplier, consideration should be given to any particular Airworthiness limitations which may be applicable to UK registered aircraft.

NOTE: This is particularly true of suppliers who have initially produced the Airworthiness data to market in foreign countries whose Airworthiness Authority may impose airworthiness limitations different to those of the CAA.

- 3.3 Persons or Organisations wishing to make use of such library services should also consider the publishers stated limitations and waivers. These will often contain statements such as – 'It is at all times the sole responsibility of the user to interpret and assess the validity of the information provided by the library'. Furthermore, it is to be remembered that the majority of the manufacturer and regulatory information contained in these libraries was not originally designed for electronic delivery. Therefore, users should be aware that variances in spelling, ATA indexing, and conventions may impact the effectiveness of searches and usage. Where any doubt exists the user should refer to the Primary Source Airworthiness data.

4 Procedural Control Considerations

- 4.1 Any person (or organisation) using Airworthiness data is responsible to satisfy himself that it has been supplied by an appropriate competent person and is in a form which is acceptable to the originator of the Primary Source material. Organisation procedures should be such that it can be demonstrated that the Airworthiness data is both up to date and available at all times when needed.
- 4.2 The library controls necessary for more traditional forms of Airworthiness data are in many cases equally applicable to that supplied in electronic format. However, organisations in choosing to use Airworthiness data provided in electronic format should take into account the following additional aspects:
- a) It is normal industry practice to provide amendments to Airworthiness data in electronic format by issuing replacement media; these amendments are often supplied at frequent intervals.
 - b) Organisations should implement procedures which ensure that access is only allowed to current versions of electronic data. Where it is considered that there is a need to have available superseded electronic data, an archive system should be implemented.
 - c) Airworthiness data, including associated temporary revisions and the ability to read the Airworthiness data, should be provided in close proximity to where the work is to be undertaken. Where printing facilities are provided, such printed material should be automatically annotated by the software to clearly identify the source of the Airworthiness data and its edition date.
 - d) The number of terminals is sufficient in relation to the volume of work to be undertaken. Suitable arrangements should also be made to ensure that in the event of a system failure, an alternative means of providing the Airworthiness data is available.
 - e) The operating system selected should not allow the unauthorised alteration of the Airworthiness data it displays.
 - f) A contract with a supplier or suppliers, should be established to maintain both the necessary hardware and software needed to access electronic Airworthiness data, reflecting the working patterns of the user. The contract should provide for the support of the system which reflects the working patterns of the users.

- g) Training as appropriate on the use of the software and hardware is to be provided to all potential users. In addition 'User Instructions' should be available at all times, at all terminals.
- h) Revision frequency in particular must be such as to ensure that users are aware of current mandatory requirements.
- i) The library subscriber is expected to be in possession of confirmation that a contract, or agreement, exists between the publisher and the manufacturer for the continuing supply of manufacturers information for the specific aircraft type.

NOTE: Further information on electronic Libraries may be found in:

BSi Code of Practice PD0008

FAA AC 120-78

ATA Specification 2100

INTENTIONALLY LEFT BLANK

Leaflet B-210 Disposition of Scrap Aircraft Parts and Materials

1 Purpose

The purpose of this Leaflet is to provide information and guidance to persons involved in the maintenance, sale, or disposal of aircraft parts. It provides additional guidance material and should be read, where applicable, with the requirements of Part-145.A.42 paragraph (d) and Part-M.A Subparts C, D and E, to prevent scrap aircraft parts and materials from being sold or acquired as serviceable parts and materials.

2 Introduction

It is common practice for owners of aircraft parts to dispose of scrap parts and materials by selling, discarding, or transferring such items. In some instances, these items have reappeared for sale in the active parts inventories of the aviation community. Misrepresentation of the status of parts and material and the practice of making such items appear serviceable could result in the use of non conforming parts and materials.

3 Types of Parts and Materials that may be Misrepresented

Persons disposing of scrap aircraft parts and materials should consider the possibility of such parts and materials being misrepresented and sold as serviceable at a later date. Caution should be exercised to ensure that the following types of parts and materials are disposed of in a controlled manner that does not allow them to be returned to service:

- a) Parts with non-repairable defects, whether visible or not to the naked eye;
- b) Parts that are not within the specifications set forth by the approved design, and cannot be brought into conformance with applicable specifications;
- c) Parts and materials for which further processing or rework cannot make them eligible for certification under a recognised released system;
- d) Parts subjected to unacceptable modification or rework that is irreversible;
- e) Life-limited parts that have reached or exceeded their life limits, or have missing or incomplete records;
- f) Parts that cannot be returned to an airworthy condition due to exposure to extreme forces or heat;
- g) Principal Structural Elements (PSE) removed from a high-cycle aircraft for which conformity cannot be accomplished by complying with the mandatory requirements applicable to ageing aircraft.

4 Methods to Prevent Misrepresentation of Scrap Parts and Materials

- 4.1 Persons disposing of scrap aircraft parts and materials should, when appropriate, mutilate those parts and materials prior to release. Mutilation should be accomplished in such a manner that the parts become unusable for their original intended use, nor

should they be able to be reworked or camouflaged to provide the appearance of being serviceable, such as by re-plating, shortening and re-threading long bolts, welding, straightening, machining, cleaning, polishing, or repainting.

- 4.1.1 Mutilation may be accomplished by one or a combination of the following procedures, but is not limited to:
- a) Grinding;
 - b) Burning;
 - c) Removal of a major lug or other integral feature;
 - d) Permanent distortion of parts;
 - e) Cutting a hole with cutting torch or saw;
 - f) Melting;
 - g) Sawing into many small pieces.
- 4.1.2 The following procedures are examples of mutilation that are often less successful because they may not be consistently effective:
- a) Stamping (such as a stamped 'R' on a part);
 - b) Spraying with paint;
 - c) Hammer marks;
 - d) Identification by tag or markings;
 - e) Drilling small holes;
 - f) Sawing in two pieces. Persons who rework scrap parts and materials may be skilled technicians and attempt to restore parts cut in two pieces in such a manner that the mutilation proves difficult to detect.
- 4.2 With regards to persons disposing of scrap aircraft parts and materials for legitimate non-flight uses, such as training and education aids, research and development, or for non-aviation applications. In such instances, mutilation is not appropriate and the following methods should be used to prevent misrepresentation:
- a) *Permanently* marking or stamping the parts, subparts, and material as 'NOT SERVICEABLE'. (Ink stamping is not an acceptable method);
 - b) Removing original part number identification;
 - c) Removing data plate identification;
 - d) Maintaining a tracking or accountability system, by serial number or other individualised data, to record transferred scrap aircraft parts and materials; and
 - e) Including written instructions concerning disposition and disposal of such parts and materials in any agreement or contract transferring such parts and materials.
- NOTE:** Scrap or expired life-limited parts and materials should not be passed on to any person or organisation who may end up placing the parts and materials back in actual use, due to the criticality of parts and material failure and the potential safety threat.
- 4.3 Organisations handling scrap or expired life-limited aircraft parts and materials should establish a quarantine store area in which to segregate such items from active serviceable inventories and to prevent unauthorised access. Caution should be exercised to ensure that these parts and materials receive the disposition specified in this Leaflet.

- 4.4 Manufacturers producing approved aircraft parts should consider maintaining records of serial numbers for 'retired' life-limited or other critical parts. In such cases, the owner who mutilates applicable parts is encouraged to provide the original manufacturer with the data plate and/or serial number and final disposition of the part.

5 Method to identify misrepresented parts

All purchasers of aircraft parts and materials should ensure that misrepresented scrap parts and materials are not received into active inventory. The following are examples of conditions to be alert for when receiving parts:

- a) Parts showing signs of rework which were purchased as 'new';
- b) Used parts showing signs of unapproved or inappropriate repair;
- c) Parts with poor workmanship or signs of rework in the area of the part data plate, number or serial number inscription;
- d) Used parts lacking verifiable documentation of history and approval;
- e) Parts with prices 'too good to be true';
- f) Questionable part numbers, fraudulent or suspicious Technical Standard Order or FAA-Parts Manufacturer Approval markings and/or re-identification, stamp-overs or vibro-etching on the data plate;
- g) Parts delivered with photocopied or missing EASA Form 1 or other acceptable maintenance release documentation;
- h) Parts with a finish that is inconsistent with industry standards (e.g. discoloration, inconsistencies, resurfacing);
- i) Parts purchased as new but with release documentation reflecting a status other than new;
- j) Parts with poor documentation exhibiting incomplete or inconsistent part identity information;
- k) Intact 'scrap' unsalvageable parts offered in bulk weight for prices higher than for mutilated parts with identical weight and content.

NOTE: Suspected Unapproved Parts Notification can be found on FAA Internet address: www.faa.gov/aircraft/safety/programs/sups/upn/ and Special Airworthiness Information Bulletins can be found on FAA Internet address: www.faa.gov/aircraft/safety/alerts/SAIB

An approved organisation or LAME who receives suspect parts should report to the CAA as detailed in paragraph 6 of CAP 562 Leaflet B-130.

INTENTIONALLY LEFT BLANK

Leaflet B-220 Return to Service of Aircraft Items Recovered from Aircraft Involved in Accidents/Incidents

NOTE: For the purpose of this Leaflet the term 'items' includes all components, parts, engines and accessories.

1 Introduction

- 1.1 This Leaflet reviews the factors involved in establishing the acceptability of aircraft items recovered from aircraft involved in accidents/incidents, and states the conditions to be met before such items may be returned to service.
- 1.2 This Leaflet applies to aircraft designated as falling under Annex II to Regulation EC 216/2008. These are known as non-EASA aircraft and come under the regulatory control of the Civil Aviation Authority and are issued with National Certificates of Airworthiness and Permits to Fly. It does not apply to EASA type certificated aircraft, which are covered by requirements defined in Part 145 and Part M.
- 1.3 The Civil Aviation Authority has evidence that some aircraft items, (including highly stressed rotating parts) have been released to service after having been recovered from aircraft involved in accidents/incidents even though the accident circumstances may have caused damage or changed characteristics from those of the type design. Since such items may not manifest any visual evidence of damage, distortion or changed characteristics, a serious airworthiness hazard could result from their use without special precautions being taken as detailed in this Leaflet.

NOTE: The subject of this Leaflet was first promulgated to industry by a CAA Letter to Operators Number 461 (revised to LTO 461/A on the 18 December 1981), following informal consultation with industry and with aviation insurers.

2 Establishing Origin of Recovered Items

- 2.1 When an aircraft has been involved in an accident/incident, the title to the salvage may pass from the insured owner to other persons (e.g. aircraft insurers) and this salvage may be offered for sale either complete or as separate aircraft items in an 'as is - where is' condition. While some items may be totally unaffected by the accident/incident which caused the aircraft to be declared as salvage, it is essential to obtain clear evidence that this is the case. If such evidence cannot be obtained, the item may not be returned to service.
- 2.2 All such items must therefore be subject to competent assessment and inspection in the light of adequate knowledge of the circumstances of the accident, subsequent storage and transport conditions, and with evidence of previous operational history obtained from valid airworthiness records, before overhaul and re-installation can be considered.
- 2.3 In particular, if a crash load is sufficient to take any part above its proof strength, residual strains may remain which could reduce the effective strength of the item or otherwise impair its functioning. Loads higher than this may of course crack the item, with an even more dangerous potential. Further, a reduction in strength may be caused by virtue of the change of a material's characteristics following overheat from a fire. It is therefore of the utmost importance to establish that the item is neither cracked, distorted nor overheated. The degree of distortion may be difficult to assess

if the precise original dimensions are not known, in which case there is no option but to reject the item. Any suggestion of overheating would be cause for a laboratory investigation into significant change of material properties.

- 2.4 The standard procedures appropriate to items removed for overhaul following normal service life may not therefore be sufficient for items from salvaged aircraft. If the information in the Manufacturer's Manual, or other technical publications, is insufficient to deal with the considerations detailed above then the manufacturer must be consulted for guidance. If the manufacturer provides the additional information, and the item can be shown to meet this, then it may be returned to service.
- 2.5 Where a difficulty exists in classifying the airworthiness significance of an aircraft item recovered after an accident/incident, the question should be referred to the CAA Airworthiness Division, Airworthiness Evaluation and Surveillance Department, for advice. The CAA will require full details of the circumstances of the accident/incident before a response is made to the enquiry.
- 2.6 It should be noted that UK licensed engineers or CAA Approved Organisations cannot inspect components or assess the implications of impact damage or fatigue without the involvement of the manufacturer or a CAA Approved Design Organisation if the existing approved data for the aircraft type does not provide appropriate and specific inspections. The component can only be released in accordance with approved data, reference BCAR Section A6-2 and CAP 562 Leaflet No. H-20.

3 Information obtained from Aviation Insurers

- 3.1 Aviation insurers and other persons who obtain title to salvage parts may supply to salvage purchasers the details of the accident/incident leading to the aircraft, or aircraft item, being declared as salvage. It is also common practice for aviation insurers to pass over the airworthiness records to the salvage purchaser. Whilst such information and records are an essential part of the assessment, where return to service is being considered, they are not a guarantee that the item is acceptable for re-installation.
- 3.2 Some aviation insurers have agreed to co-operate with the CAA's attempt to prevent items being returned to service if their airworthiness cannot be confidently confirmed. They have agreed to supply details of the occurrence, and to identify the party to whom the salvage has been sold, to the Airworthiness Division, Application and Approvals Department. This information may be relevant when CAA advice is sought under paragraph 2.5 of this Leaflet, but does not excuse the enquirer from furnishing the information required by that paragraph.

4 Supplementary Information

- 4.1 Attention is drawn to CAP 562 Leaflets B-130 and C-140 which also deal with the safeguards necessary for users obtaining aircraft parts in the open market, particularly in relation to the release documentation and evidence of previous history.

Leaflet B-230 Overhauls, Modifications, Repairs and Replacements to Aircraft not Exceeding 2730 kg with a National Certificate of Airworthiness in the Special Category

- 1 There have been a number of accidents to aircraft in the above Category on which it was subsequently established that work had been done which was such that, under Article 19 of the Air Navigation Order 2009 (as amended), the Certificate of Airworthiness may have ceased to be in force.
- 2 Article 19 (a) of the Air Navigation Order 2009 (as amended), provides that a Certificate of Airworthiness issued in respect of an aircraft shall cease to be in force if the aircraft, or such of its equipment as is necessary for the airworthiness of the aircraft, is overhauled, repaired or modified, or if any part of the aircraft or of such equipment is removed or is replaced, otherwise than in a manner and with material of a type approved by the Authority either generally or in relation to a class of aircraft or to the particular aircraft.
- 3 Although Article 29 of the Order specifically excludes certain Special Category aircraft from the requirements for the issue of Certificates of Release to Service, the provisions of Article 19 apply to all aircraft without exception. Any person, therefore, who intends to undertake work on an aircraft covered by this Leaflet should only do so when he is in possession of adequate knowledge of the tasks involved, has access to the necessary facilities and the relevant maintenance, overhaul or repair manuals, and uses parts or materials which are known to satisfy CAA requirements. If any doubt exists as to whether these conditions are met, the person concerned should seek advice from a CAA approved organisation or a licensed aircraft maintenance engineer.

It is emphasised that a person who flies an aircraft when the Certificate of Airworthiness has ceased to be in force by virtue of Article 19 of the Air Navigation Order 2009 (as amended), may render himself liable to prosecution for contravention of Article 16 of the Order and there may be other serious consequences.

INTENTIONALLY LEFT BLANK

Leaflet B-240 Aerobatic Manoeuvres

1 Introduction

- 1.1 Certain light aircraft on the British Register are permitted to perform a wide range of aerobatic manoeuvres although designed for a positive load factor of less than 6 g (usually the 4.4 g Semi-Aerobatic Load Factor given in British Civil Airworthiness Requirements). This is because, during certification of these aircraft, the permitted aerobatics were evaluated and the design strength was found to provide an adequate margin to permit them to be performed safely.
- 1.2 However, recording accelerometers were installed in some aircraft to determine (for fatigue life estimation) the actual loadings achieved. These recordings have shown that *g* loadings in excess of those to which the aircraft were designed have been imposed in service on a sufficiently large number of occasions to suggest that there is a risk that loads greater than the strength of the aeroplane may be imposed inadvertently.
- 1.3 This evidence has been collected on aeroplanes of relatively low aerodynamic drag, and there is no evidence to suggest that any problem exists on aeroplanes of relatively high drag such as biplanes, many of which have a long and satisfactory history.
- 1.4 Historically, some types, specifically identified as susceptible to inadvertent application of excessive load factor, received appropriate amendments to the Flight Manual and were required to have a cockpit warning placard installed. The national responsibility to mandate these no longer remains for EASA aircraft but the requirement for a Flight Manual statement and cockpit placard remains in place for non-EASA aircraft of Annex II to EC Regulation 216/2008.

2 Warning

Pilots of aeroplanes designed to semi-aerobatic load factors (i.e. less than 6 g to limit load) are warned that they should take care not to apply excessive *g* in the permitted aerobatic manoeuvres.

INTENTIONALLY LEFT BLANK

Leaflet B-250 Chipmunk Spinning and Aerobatics

PURPOSE: The purpose of this Leaflet is to acquaint pilots with a background of information on:

- a) the long chord rudder;
- b) anti-spin strakes on the rear fuselage;
- c) behaviour of the aircraft when spinning and attempting to spin;
- d) the necessary spin recovery action; and to acquaint the pilots with the contents of the Flight Manual.

REFERENCES: Various, as quoted in Leaflet.

1 Introduction

Considerable numbers of de Havilland Chipmunks have come onto the civil register from the Royal Air Force. Unfortunately, because accidents have occurred, the aeroplane has become the subject of ill-informed rumours about its spinning characteristics.

2 Long Chord Rudder (de Havilland Modification H 104)

The long chord rudder was introduced at the request of the Royal Air Force to improve handling during aerobatics. Specifically, the modified rudder enables the pilot to hold the nose up during slow rolls, and improves control when sideslipping and during a cross-wind take-off or landing.

The modified rudder can be identified on sight by the markedly curved trailing edge and the presence of small bite at the trailing edge where it joins the root rib (to give up-elevator clearance when full rudder is applied).

The long chord rudder was not introduced to improve spin recovery – nor has it been proved during extensive tests to have the slightest effect upon recovery from a spin. It does, however, improve spin entry because the pilot can achieve greater yaw, making a spin more likely than the spiral dive, which has often been confused with a spin.

3 Anti-spin Strakes (de Havilland Modification H 231)

The anti-spin strakes consist of extensions forward of the tailplane roots, some 3 feet in length, faired into the fuselage sides. Their purpose is to increase the aerodynamic drag of the tail, thus tending to damp rotation in yaw, and steepening the spin.

The strakes improve spin recovery, by reducing the number of turns taken before rotation ceases after corrective control movements have been applied.

Considerable experience has produced no evidence that the improved spin recovery of a Chipmunk fitted with strakes is affected in any way by the fitting of either a standard or a long chord rudder.

4 **Condition of the Aircraft**

Everything that follows presupposes that:

- a) control surface rigging is maintained within limits;
- b) control cable tension is maintained within limits;
- c) the leading edges of wing and tail surfaces are not significantly damaged or dented;
- d) the weight and centre of gravity are within limits;
- e) the engine idling rpm is within limits.

NOTE: It is important that no pilot embarks upon an aerobatic or spinning sortie without first checking the loading of his aeroplane.

5 **Aerobatics**

Aerobatic and spinning manoeuvres are not permitted unless the aeroplane is fitted with anti-spin strakes (de Havilland Modification H 231).

When aerobatic manoeuvres are permitted such manoeuvres shall be performed with:

- a) cockpit canopy SHUT and LOCKED;
- b) wheel brakes OFF to ensure full rudder travel;
- c) flaps UP;

additionally:

- d) elevator trim NEUTRAL;
- e) harness TIGHT and LOCKED;
- f) direction indicator CAGED;
- g) mixture RICH;
- h) carburettor air AS REQUIRED;
- i) oil temperature and pressure WITHIN LIMITS;
- j) fuel SUFFICIENT.

6 **Spinning Manoeuvres**

The aeroplane is hard to spin properly at almost all centre-of-gravity positions. The characteristics of one aircraft may differ from another: where one will spin, another will only enter a semi-stalled spiral dive, and one aeroplane may do either. The difference in behaviour depends upon such variables as weight and position of centre of gravity, the intended spin direction, and aileron deflection into or out of the direction of spin.

As the spiral and the spin can be confused, it is essential to differentiate between them. The characteristics of the spiral dive and the spin are as follows:

The Semi-Stalled Spiral Dive

The spiral resembles a spin, and is more likely to occur in conditions of forward centre of gravity.

The following points indicate that the spiral is in fact a semi-stalled spiral dive without auto-rotation (the characteristic of the true spin):

- a) the attitude is steep;

- b) the airspeed will increase from 40 knots IAS at the start to 80-90 knots IAS after two turns with the stick fully back and full rudder to maintain the manoeuvre;
- c) the controls retain the forces of normal manoeuvres, but there is some buffeting of the tail;
- d) there is usually noticeable noise and rattle resulting from buffeting at increasing IAS;
- e) upon releasing the controls the aeroplane will recover by itself, or with some opposite rudder, after rotating through one quarter to one half a turn.

The Spin

The spin has the following characteristics:

- a) the attitude is steep initially but after two or three turns the spin may become less steep with the nose generally 30° to 50° below the horizon, while appearing to be less so;
- b) the airspeed remains steady, between 30 knots and 50 knots IAS;
- c) the rudder force is light;
- d) the stick force is light when aft of neutral; a relatively heavy push force is needed to move the stick fully forward, and this may be accompanied by some buffeting.

7 Spin Procedure

The spin should be started at 50 knots by applying full rudder in the required direction, and moving the stick fully back. If the stick is not moved fully back until the spin has been entered, a semi-stalled spiral dive may be encountered. In addition to the normal pro-spin control movements, it is often necessary to force a reluctant aeroplane to enter a spin by use of aileron against the intended direction of spin. If aileron is so used it should be centralised when entry is achieved.

When finally spinning the nose of the aircraft gradually rises, and the flatter attitudes may cause longer recoveries than for many other types of aircraft. It is important for a pilot to appreciate that:

- a) full and decisive control movements are needed to recover, particularly nosedown elevator, which may require a considerable push force;
- b) the rate of spin rotation may increase momentarily when anti-spin controls are applied; this is to be taken as an indication that the correct actions have been followed;
- c) standard recovery action is effective as long as one has the required altitude, and a conscious effort is made to apply and maintain full opposite rudder and full forward stick;
- d) normal recovery action takes place in one to two turns, which may involve a height loss of 1,000 feet to straight and level flight. Exceptionally, the recovery may take up to four and one half turns involving a total height loss around 2,000 feet.

Drills

Before starting the spin, check:

- a) cockpit canopy SHUT and LOCKED;
- b) wheel brakes OFF to ensure full rudder travel;
- c) flaps UP;

additionally:

- d) elevator trim NEUTRAL;
- e) harness TIGHT and LOCKED;
- f) direction indicator CAGED;
- g) mixture RICH;
- h) carburettor air AS REQUIRED;
- i) oil temperature and pressure WITHIN LIMITS;
- j) fuel SUFFICIENT.

The aeroplane should be spun with 1) throttle CLOSED, 2) full rudder and 3) stick fully back.

NOTE: If aileron is applied against the direction of the spin, it must be centralised when entry is achieved.

Spin Recovery must be started at least 3,500 feet above ground level, in order to retain level flight by 1,500 feet, consistent with a height loss during recovery of up to 2,000 feet.

- a) check throttle CLOSED;
- b) check ailerons CENTRAL;
- c) apply full OPPOSITE RUDDER;
- d) PAUSE;
- e) move the stick firmly FORWARD against the increasing stick force and stick buffet, IF NECESSARY TO THE FRONT STOP and hold it there until rotation ceases;
- f) when rotation ceases CENTRALISE the rudder control and ease out of the ensuing dive.

8 Placards

All civil Chipmunks cleared for aerobatics (i.e. fitted with anti-spin strakes) display the following placard in full view of each pilot, in the prescribed position (HSA Modification H324).

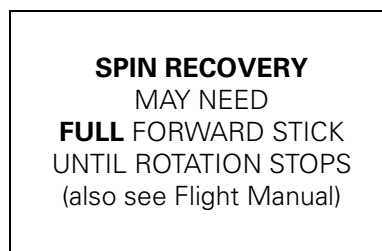

Aircraft not cleared for spins and aerobatics must display the following placard, in full view of each pilot, in the prescribed position (HSA Modification H323).

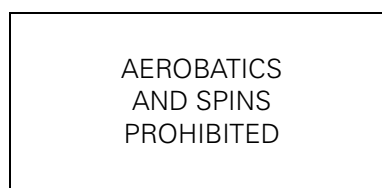

Chapter C Airworthiness Procedures

Leaflet C-20 Approval of Organisations

1 Introduction

Any design, production or maintenance organisation seeking an approval in order to satisfy regulatory requirements should in the first instance make contact with the address given below. Advice will be provided as to the method of application and fees required.

Applications and Approvals Section
2E Aviation House
Gatwick Airport South
West Sussex
RH6 0YR

Email: aanda@caa.co.uk

Approved Organisations

A list of organisations approved by the CAA under the Air Navigation Order and by the European Aviation Safety Agency (EASA) can be found on the CAA website at www.caa.co.uk/UKAO.

2 Approval of Organisations for Maintenance of Aircraft and Components

2.1 Purpose

The purpose of this Leaflet is:

- a) to provide guidance to UK industry on CAA approval policy with respect to Part-145 approval of maintenance organisations engaged in the maintenance of aircraft used for Commercial Air Transport or in the maintenance of components to be fitted to such aircraft; and
- b) to set out CAA policy concerning maintenance approvals and requirements relating to aircraft NOT used for Commercial Air Transport (EASA and non-EASA) and relating to maintained components to be fitted to such aircraft.

NOTE: For the purpose of this Leaflet, 'Maintenance' means any one or combination of Overhaul, Repair, Inspection, Modification or defect rectification of a component.

2.2 Introduction

2.2.1 Part-145 covers the approval of organisations engaged in the maintenance of aircraft or aircraft components used for Commercial Air Transport, and applies to all large aircraft, regardless of use. Part-145 and the Acceptable Means of Compliance and Guidance Material is available on the EASA Website.

NOTE: For the purpose of this regulation a "large aircraft" means an aeroplane with a Maximum Take-Off Mass (MTOM) exceeding 5700 kg, or a multi-engine helicopter.

2.2.2 Organisations approved by the CAA to Part-145 will have details of their approval, including their name and address, listed on the CAA website at www.caa.co.uk/UKAO. Part-145 Approvals granted to organisations by EASA or competent authorities within other EU Member States are recognised in the UK without further evaluation.

2.2.3 Part M, Subpart F covers the approval of organisations engaged in the maintenance of aircraft with a MTOM not exceeding 5700 kg and single engine helicopters not engaged in Commercial Air Transport.

2.3 CAA Approval Policy for Part-145 Requirements

2.3.1 Part-145 came into effect on 29 November 2003 for the maintenance of all EASA aircraft when used for Commercial Air Transport (CAT), and from 28 September 2008 to include all large aircraft regardless of use. The Certificate of Release to Service (CRS) required after maintenance of an aircraft or an aircraft component used on a large aircraft, or any aircraft used for Commercial Air Transport, can only be issued by an organisation appropriately approved in accordance with Part-145.

NOTE: It is incumbent upon UK organisations placing maintenance work with other approved organisations to confirm the validity of that 'approval'. Reference should be made to the list of organisations approved by the CAA at www.caa.co.uk/UKAO and EASA lists of approved organisations.

2.4 Certifying Staff

2.4.1 Organisations applying for Approval under Part-145 for the maintenance of aeroplanes or rotorcraft will be required to demonstrate to the CAA that they employ, in accordance with the requirements of Part-145.A.30, a sufficient number of appropriately qualified certifying staff who hold:

- a) Part-66 licences in the appropriate category or sub-category issued by an EU Member State competent authority including, where appropriate, the relevant aircraft type ratings; or
- b) Part-66 restricted licences in the appropriate category or sub-category issued by an EU Member State competent authority including, where appropriate, the relevant aircraft restricted type ratings.

NOTE: Organisations must ensure that care is taken in determining what training must be undertaken to extend any authorisation held, since even with restricted Part-66 licences, the imposed limitations endorsed by each NAA may differ.

2.4.2 Organisations holding or applying for Approval for the maintenance of Airships must meet the relevant requirements of BCAR Section A, Chapter A8-18 and its associated supplements. Certification authorisations will, until such times as appropriate provision for Airship licences has been incorporated into Part-66, be based upon BCAR Section L, Category 'A and C' airship LWTRs. Unless agreed otherwise by the CAA, type training will be required to be conducted by a suitably approved Part-147 organisation.

2.4.3 Organisations holding or applying for Approval for the maintenance of Sailplanes or Balloons should follow the guidance set out in CAP 562 Leaflet H-40, until such times as appropriate provisions for Sailplanes and Balloons have been incorporated into Part-66.

2.4.4 Organisations holding or applying for Approval under Part-145 or Part M Subpart F will be required to demonstrate to the CAA that they employ a sufficient number of certifying staff, who hold the appropriate type rated licences issued under Part-66, to be authorised to issue Certificates of Release to Service for all required maintenance.

2.4.5 Organisations holding or applying for Approval for the maintenance of aircraft components intended for fitment to aircraft used for Commercial Air Transport, are required to demonstrate to the CAA that they employ sufficient numbers of certifying staff (Part 145.A.30(d)), who are qualified by the organisation to issue an EASA Form 1 (Certificate of Release to Service) on the basis of appropriate competence, training and experience.

NOTE 1: If component maintenance is required which is outside the scope of work of a Part-145 'A' rated organisation, it must be Released to Service by an appropriately Part-145 'B', 'C' or 'D' rated organisation. When a Part-145 'B', 'C' or 'D' rated organisation performs maintenance on components fitted to an aircraft during Base or Line maintenance, the Certificate of Release to Service must be issued on an EASA Form 1 by appropriately authorised component certifying staff. The process for controlling such work on components fitted to aircraft must be in accordance with a procedure contained in the Maintenance Organisation Exposition (MOE).

NOTE 2: It is the intention of EASA to include requirements for qualification standards for certifying staff involved in component maintenance in a future amendment to Part-66.

2.4.6 The current licensing arrangements under BCAR Section L apply to non-EASA aircraft as defined by Annex II of Regulation (EC) No 216/2008.

2.5 **CAA Approval Policy for National Requirements – Non-EASA Aircraft**

2.5.1 Organisations which are solely engaged in the maintenance of aircraft not exceeding 2730 kg Maximum Take-Off Mass which are NOT used for Commercial Air Transport, may continue to be approved, or may apply for the grant or variation of an approval, in accordance with the requirements of BCAR Sub-section A8. An approval granted under this requirement would be a CAA 'National' approval.

2.5.2 Organisations which are engaged in the maintenance of aircraft exceeding 2730 kg Maximum Take-Off Mass which are NOT used for Commercial Air Transport will be subject to the appropriate BCAR Maintenance Approval Group Requirements under BCAR Sub-section A8.

2.5.3 Organisations engaged in the maintenance of components for which there is no intended use for Commercial Air Transport may also apply for Approval in accordance with these Requirements (see 2.5.1 and 2.5.2).

2.5.4 Application for changes/variations to existing maintenance approvals granted under BCAR Sub-section A8 will continue to be accepted by the CAA from organisations where Part-145 approval is not necessary.

2.6 **CAA Approvals**

2.6.1 Organisations which hold Part-145 or Part M Subpart F Approval or an appropriate CAA National Maintenance Approval may continue to be granted these terms of Approval if they meet the appropriate requirements. There are a number of functions which can be covered by a CAA Approval that are not as yet addressed by EASA Requirements. These functions include (but are not limited to) the following:

- a) To issue Certificates of Maintenance Review in accordance with Article 26 of the Air Navigation Order 2009 (as amended) when required;
- b) To issue Certificates of Release to Service in accordance with Article 28 of the Air Navigation Order 2009 (as amended) when required;

NOTE: This Approval relates to the certification of work on aircraft and/or components NOT used for Commercial Air Transport.

- c) To issue Certificates of Fitness for Flight in accordance with the provision of BCAR Chapter A/B 3-8, ('A' Conditions) and to issue a Flight Release Certificate for an EASA Permit to Fly;
- d) To perform Star Inspections in accordance with BCAR Chapter A/B 3-4;

- e) To furnish reports to the CAA in accordance with Article 244 of the Air Navigation Order 2009 (as amended) in respect of:

Assessments and recommendations for the Renewal of the Certificate of Airworthiness for aircraft as defined in the Maintenance Organisation Exposition, as Approved in accordance with BCAR Chapter A8-15, or as Approved in accordance with BCAR Chapter A8-3;

- f) To amend Maintenance, Overhaul, Repair Manuals and Wiring Diagrams in accordance with BCAR Chapter A/B 5-3;
- g) Control of Welders Approvals.

2.7 Maintenance of EASA Aircraft

2.7.1 Non Commercial Air Transport

2.7.1.1 Aircraft on the UK Register, which are NOT used for Commercial Air Transport, may only have maintained components fitted, which have been released to service in accordance with Part-145 or Part M Subpart F.

2.7.1.2 The person issuing the Certificate of Release to Service for the fitting of a component to an aircraft on the UK register is responsible for ensuring that the records of that component are sufficient to enable its maintenance and operating history to be established, including the embodiment of modifications and mandatory ADs, service life used etc.

2.7.2 When changing from any Non Commercial Operation (non-CAT) to Commercial Air Transport Operation (CAT)

2.7.2.1 Aircraft will require release to service by an appropriately approved Part-145 organisation, prior to the aircraft being used for Commercial Air Transport. The release to service may, for example, be in accordance with the alignment check required to transfer the aircraft from the current aircraft maintenance programme to the Commercial Air Transport operator's approved maintenance programme.

NOTES: 1 For aircraft with an MTOM not exceeding 2730 kg, the maintenance checks for this alignment shall be at minimum, but not limited to, a 100 hour check for helicopters or a 150 hour check for aeroplanes in accordance with the LAMP; or the approved alternative CAA approved maintenance schedule.

2 For aircraft with an MTOM exceeding 2730 kg the Maintenance Check content for alignment shall be agreed by the CAA to be of sufficient depth to provide a satisfactory level of assurance of airworthiness.

3 A Part-145.A.50 Certificate of Release to Service will be issued on completion of an alignment check as required above.

4 Operators of aircraft that may transfer between CAT and non-CAT operations must ensure that all aircraft and component maintenance is released by an appropriately approved Part-145 organisation, or accept the need for assessment and re-certification as necessary by a Part-145 organisation before commencing Commercial Air Transport Operations.

2.7.2.2 Components (including engines and equipment) that have been overhauled or maintained in accordance with paragraph 2.8.1 or 2.8.2 will require assessment by a Part-145 approved organisation prior to the aircraft to which these components are fitted being used for the purposes of Commercial Air Transport.

- 2.8 Maintenance of Components (including Engines, Propellers, APUs and Equipment)**
- 2.8.1 EASA Aircraft – Excluding Commercial Air Transport and Large Aircraft**
- NOTE:** 'Large Aircraft' means an aircraft classified as an aeroplane with a Maximum Take-Off Mass exceeding 5700 kg or a multi-engined helicopter.
- 2.8.1.1 Components (including engines and equipment) that are intended for fitment to aircraft not used for the purpose of Commercial Air Transport may be released to service by organisations approved in accordance with Part-145 or Part M Subpart F for that aircraft or component.
- 2.8.1.2 Components that have been maintained by organisations not approved in accordance with Part 145 or Part M Subpart F, due care should be exercised before acceptance. An appropriately rated maintenance organisation should establish satisfactory conditions (M.A.613(a) refers) by, dismantling the component to allow sufficient inspection in accordance with the appropriate maintenance data, replace all service life limit components where no satisfactory evidence of life used is available, or are in an unsatisfactory condition, reassembling and testing as necessary, completing all certification requirements.
- 2.8.1.3 Part M Subpart F approved maintenance organisations (not rated for components) may issue a Form 1, after appropriate checks and verifications, for components that have been released after maintenance with an 8130-3 (FAA) or TCCA 24-0078 (Canada) without dual release. This does not apply to new components, as in such cases, an FAA 8130-3 or TCCA 24-0078 issued by the manufacturer are acceptable.
- 2.8.1.4 Maintenance on a component whilst installed or temporarily removed from an ELA1 aircraft not used for Commercial Air Transport, and performed in accordance with the Component Maintenance Manual (CMM), may be performed by a Part 66 licensed engineer using the correct tools, equipment and material, with proper facilities and with regard to the environmental conditions. The exception to this is that the Part 66 licensed engineer cannot overhaul components, but can overhaul engines and propellers for aircraft certified under CS-VLA, CS-22 and LSA.
- 2.8.2 Non-EASA Aircraft**
- 2.8.2.1 Components (including engines, propellers, APUs and equipment) that are intended for fitment to non-EASA aircraft as defined in EC Regulation 216/2008 Articles 1(2) and 4(4) (the current list may be found in CAP 747 Mandatory Requirements for Airworthiness, Section 1, Part 2) may be released to service by an organisation approved in accordance with BCAR Sub-Section A8 and holding the rating for that aircraft or component.
- 2.9 Bilateral Aviation Safety Agreement (BASA)**
- 2.9.1 A full listing of EASA Part-145 approved maintenance organisations in the USA and Canada is available on the EASA website.
- 2.10 Charges**
- 2.10.1 Full details of the charges associated with CAA approval are prescribed in the Official Record Series 5, which is available on the CAA web site at www.caa.co.uk/ORS5.
- 2.11 Application**
- 2.11.1 Enquiries regarding the grant of a Part-145 approval, Part M Subpart F approval or a CAA Maintenance Approval to National requirements should be made in writing to the Safety Regulation Group, Aviation House, Gatwick Airport South, West Sussex RH6 0YR, marked for the attention of the Applications and Approvals Department.

Further information will then be supplied, including an application form. Applications for Part-145 approval from organisations outside the EU territories should be made directly to EASA.

Appendix 1 Subcontracting to Non-Approved Organisations

1 General

1.1 The UK CAA has from the 28 September 2005 cancelled the approval of those organisations approved in accordance with BCAR in the following categories: A8-1, A8-2, A8-4, A8-5, A8-6, A8-7, A8-9, A8-16 and A8-19, unless involved with the design or manufacture of non-EASA aircraft.

NOTE: Non-EASA aircraft are those aircraft not included as an EASA aircraft for the following reasons:

- a) identified within Annex II of EC Regulation 216/2008;
- b) excluded by Article 1, paragraph 2 of EC Regulation 216/2008;
- c) currently excluded by Article 2, paragraph 3 (c) of EC Regulation 1702/2003.

As approvals A8-5 and A8-6 have a considerable impact on aircraft maintenance and continuing airworthiness, paragraphs 2 and 3 of this appendix are raised to provide guidance on the subcontracting of these activities.

1.2 In order to issue a Part 145.A.50 Certificate of Release to Service of an aircraft component used in Commercial Air Transport, an organisation must meet one of the following criteria:

- a) an organisation is approved in accordance with Part-145;
- b) an organisation is contracted to another appropriately approved Part-145 organisation; or
- c) an organisation is working under the quality system of an appropriately approved Part-145 organisation (AMC 145.A.75(b)) – this arrangement is known as "subcontracting".

1.3 An organisation with Part M Subpart F approval may arrange for specialised services to be performed at another appropriately qualified organisation in accordance Part M point M.A.615(b), when the organisation has established procedures in its Maintenance Organisation Manual when approved by the CAA.

2 Introduction

2.1 Part 145.A.75(b) permits an organisation that is not appropriately approved in accordance with Part-145 to carry out certain maintenance tasks whilst working under the quality system of an approved Part-145 organisation – this is commonly referred to as subcontracting.

2.2 Part M M.A.615(b) permits a Subpart F approved organisation to arrange for specialised services to be performed by another appropriately qualified organisation (the organisation should meet an officially recognised standard, or is acceptable to the CAA).

2.3 Part-145 and Part M Subpart F organisations frequently need to subcontract certain specialised maintenance tasks such as: plating, heat treatment, plasma spray, fire testing, etc., without the need for the subcontractor to be directly approved in accordance with Part-145 or Part M Subpart F in their own right.

- 2.4 The UK CAA will accept an appropriate United Kingdom Accreditation Service (UKAS) accredited laboratory certificate where applicable for specialised maintenance tasks such as: heat treatment, fire testing, etc. Further information is given in CAP 562, Leaflet C-40.
- 2.5 When maintenance is carried out under a subcontract control system, it means that for the duration of such maintenance the subcontracting organisation's approval has been extended to include the subcontractor, and requires the quality audit staff to ensure the Part-145 requirements are satisfied. Or in the case of Subpart F, the specialist services are controlled by the maintenance organisation.
- 2.6 The approved organisation should have the necessary competence, expertise and procedures to allow it to determine that the subcontractor is able to comply with the particular process/standard identified in the contract.
- 2.7 The contract between the approved organisation and the unapproved subcontractor should contain a provision for the competent authority and EASA standardisation team staff to have right of access to the subcontractor.

3 Procedure for Acceptance of Work from Non-Approved Organisations for Part-145 and Part M Subpart F Organisations

- 3.1 When work is subcontracted or passed to a non-approved organisation, the organisation's procedures must make the following provisions:
- a) the pre-audit procedure should ensure that the company has a valid national accreditation where applicable, acceptable to the CAA (e.g. United Kingdom Accreditation Service);
 - b) the approved organisation should ensure the subcontractor providing the specialised service is listed in their Maintenance Organisation Exposition (Part 145) or Maintenance Organisation Manual (Subpart F);
 - c) the subcontracted process associated control procedures should be fully described in the approved organisation's procedures including the acceptance of the format for the release of the contracted work;
 - d) the subcontract control procedure will need to ensure the national accreditation, where applicable, remains valid and appropriate for the contract required;
 - e) for Part-145, the quality audit staff will need to audit their subcontract control section and sample audit the subcontractors when appropriate, as part of the quality programme;
 - f) the depth of the audit should be reflected in the accreditation, if any, held by the unapproved organisation;
 - g) the Certificate of Release to Service or EASA Form 1 for the release of the task or process will always be issued under the approved maintenance organisation approval reference;
 - h) the Certificate of Release to Service may be issued either at the subcontractor or at the organisation facility, by staff issued with a certification authorisation;
 - i) such staff would normally come from the approved organisation but may otherwise be a person from the subcontractor who meets the approved maintenance organisation certifying standard, which is itself approved by the competent authority via the maintenance exposition/manual.
- 3.2 When listing a non-approved organisation as a subcontractor the appropriate national accreditation status must be identified.

Appendix 2 Acceptable Data for use by Part M Subpart F Organisations, Part-145 Organisations and Independent Part-66 Certifying Staff

1 General

- 1.1 The UK CAA frequently receives questions from Part M Subpart F Organisations, Part 145 Organisations and Independent Part 66 Certifying Staff asking what data is approved and acceptable to use when implementing repairs. There seems to be a lack of definition in the current regulations as to what exactly is required, in terms of data, paperwork and approval status, especially for repair data coming from outside the EU. In order to assist, we have put guidance material together for UK industry that we hope will provide some clarity on this issue.

2 Introduction

- 2.1 Currently EASA will accept the design approval of repair data in one of the following ways:
- a) By being accepted by any EU member state prior to 28 September 2003;
 - b) Under Part-21 Subpart M;
 - c) Under a Decision issued by EASA.
- 2.2 Repair approval under a) and b) are believed to be well understood, but there may remain some confusion over c).
- 2.3 In December 2004, EASA issued Decisions 2004/02/CF, 2004/03/CF and 2004/04/CF (see http://www.easa.europa.eu/ws_prod/g/rg_agency_desc_main.php) that allow for the acceptance of repair designs for products where the USA, Canada or Brazil is the State of Design. This acceptance was based upon the repairs being approved under those national systems. How those systems work and what is and what is not acceptable under those systems may not be clear to the majority of those who may wish to make use of these Decisions.

3 Acceptable Data

- 3.1 In order to prevent either using data that is not approved under those systems or demanding more than is required, it is recommended that the following actions are taken:
- a) For the acceptance of minor repair data under the oversight of the National Aviation Authorities of USA, Canada and Brazil, it is recommended to obtain confirmation that:
 - the repair design is provided by persons suitably regulated under the National Authority's system (see Note for examples for the USA's system);
 - the repair has clearly been classified as minor or non-major;
 - the repair has been developed from data acceptable to the National Aviation Authority.

- b) For the acceptance of major repair data under the oversight of the National Aviation Authority of USA, Canada and Brazil, it should be ensured that the repair has received the approval of the National Authority (USA, Canada, Brazil) in whatever form is accepted in that state (e.g. FAA form 8110-3, 8100-9 or FAA form 337 for the USA, Repair Design Certificate in Canada).

The decision 2004/04/CF has subsequently been amended by ED Decision 2007/001/C with effect from 1 April 2007, that effectively allows repair design not related to a critical part of a product approved under the FAA system to be automatically approved by EASA, not just those coming from the TC or STC holder. Guidance material is provided on this Decision on the EASA website, certification/design approvals/repair design (Exceptions section) in a document with the title "Repair design data developed by US organisations/persons for use on EU-registered aircraft and related articles".

For repair data coming from countries other than the EU, USA, Canada or Brazil, Part-21 GM 21A.431(a) provides a flow chart for repairs coming from outside the EU. Effectively the repair can only be approved by the Agency, or if classified minor, by an appropriately approved Part-21 DOA organisation.

NOTE: Those eligible to generate repair data under the FAA system (i.e. acceptable source for minor repair data):

- a) Delegation Option Authorization (DOA). A manufacturer holding a current type certificate and production certificate issued under standard procedures that is authorised by the FAA to conduct type, production, and airworthiness certification functions in accordance with 14 CFR part 21, subpart J.
- b) Designated Alteration Station (DAS). A repair station, air carrier, or manufacturer authorised by the FAA to issue Supplemental Type Certificates in accordance with 14 CFR part 21, subpart M.
- c) SFAR 36. A repair station, air carrier, or commercial operator authorised to develop and use major repair data that are not specifically approved by the FAA Administrator in accordance with SFAR 36. (SFAR 36 is found in the regulations at the beginning of 14 CFR part 121.)
- d) Designated Engineering Representative (DER). DERs have various approval types, and can either work independently or as part of a larger design organisation.
- e) Type Certificate Holder. This would include US manufacturers such as Boeing, Cessna etc. if not covered under a DOA.
- f) US Operators. This is not seen as a common option for obtaining minor repair data within Europe. Within the FAA system some US operators, if they have been appropriately approved, are granted the authority to classify and design minor repair data. The approval status of the operator would need to be established prior to acceptance and implementation of the repair design.

Leaflet C-30 CAA Approvals – Non Transferability

1 Introduction

This Leaflet provides advice and information to CAA Approved Organisations concerning the legal implications and CAA approvals policy relating to company name changes and/or the transfer of business and assets to another company.

2 General

The present business climate is resulting in increasing numbers of CAA Approved Organisations either changing their name and/or transferring their business and assets to another company. It is essential therefore that registered companies advise the CAA of such changes before they take place, and understand the impact the changes may have upon continuation of their CAA approval.

NOTE: Under the Civil Aviation Act, no information furnished to the CAA under the ANO shall be disclosed by the CAA except under the specific provisions of the Act.

3 CAA Approvals

- 3.1 CAA Approval is granted to a legal entity and, in the case of an organisation, this is clearly identified with its company registration number. A CAA Approval once granted is not transferable from one registered company to another.
- 3.2 When the business and assets of a CAA Approved Organisation (company A) are sold or transferred to another company (company B), the CAA Approvals issued to company A become null and void at that time and no further design or release certifications may be made. If company B is not already approved by the CAA, for it to operate as a CAA Approved Organisation, it will be necessary to make an application for a new approval to the CAA. Since each CAA Approval is identified by a unique reference number, the issue of a new CAA approval will necessitate amendment of company documentation to show the new number. In many cases the new CAA approval can be issued in an expeditious manner providing no other changes have occurred in the company which would affect the approval. If company B already holds a CAA approval, it may be necessary for it to apply to vary the approval to assimilate the activities of company A and in such circumstances advice should be sought from the CAA prior to the acquisition.
- 3.3 Where a company changes its name but its company registration number remains the same, the legal entity has not changed and therefore the existing CAA approval can continue, using the same approval number, providing adequate prior notice is given.
- 3.4 In either case, a CAA Certificate of Approval will need to be issued to approve the new company or record the change of name. Therefore, it is important for organisations to contact the CAA at the earliest opportunity when a change of status as detailed above is to take place. It should be noted that an appropriate Certificate of Incorporation (if applicable) will be required as evidence of the change before a new approval certificate can be issued.
- 3.5 Any fees associated with the investigation of approvals and the issue of new documents will be in accordance with the current CAA Scheme of Charges.

INTENTIONALLY LEFT BLANK

Leaflet C-40 CAA recognition of Test Houses Holding United Kingdom Accreditation Service (UKAS) Accreditation

1 Introduction

- 1.1 The CAA is satisfied that the standards achieved by the United Kingdom Accreditation Service (UKAS) for Test House accreditation are acceptable as a Sub Contract oversight activity for those organisations that hold a British Civil Airworthiness Requirement (BCAR) Approval, a Part 21 Production Organisation Approval (POA), Part 145 Maintenance Organisations Approval or a Part M Sub Part F Maintenance Organisation.
- 1.2 You may need to apply to UKAS to become accredited or to have a specific test added to your accreditation schedule.

2 Application

- 2.1 The CAA will not be granting a formal approval therefore no application to the CAA is to be made. (See Paragraph 3 Conditions.)

3 Conditions

- 3.1 A Test facility shall submit to the CAA:
 - A statement signed by the organisation's Chief Executive that the management of the organisation will grant access to the CAA to surveillance and assessment reports prepared by UKAS during the course of the accreditation.
(A sample of the wording to be supplied on company letterhead is provided in Appendix 1 to this Leaflet).
 - The latest issue of your company's UKAS accreditation schedule.

4 Continuation of Recognition

- 4.1 Recognition will be based on continued UKAS Accreditation for Aerospace requirements / specifications as stated in the UKAS accreditation schedule.
- 4.2 The CAA shall have access to the organisation for the purpose of assessing the standard in use from time to time in conjunction with UKAS reassessment or surveillance visits.
- 4.3 The Organisation shall consult with the CAA if there is difficulty in interpreting Aerospace requirements or specifications that have been published by the CAA.
- 4.4 The CAA shall have the right to witness tests in any way associated with establishing airworthiness.

INTENTIONALLY LEFT BLANK

Appendix 1

LABORATORY'S LETTERHEAD

United Kingdom Accreditation Service
21-47 High Street
Feltham
Middlesex
TW13 4UN

The United Kingdom Accreditation Service (UKAS) is hereby authorised to communicate to the Civil Aviation Authority (CAA) information concerning this laboratory's compliance or otherwise with UKAS requirements, in connection with the laboratory's eligibility for recognition by the CAA at the site(s) listed below. It is understood that the CAA undertakes to hold this information in confidence, subject to the law of the land.

In addition, it is declared that the Quality Manual, reference no.#..... defines the organisation and procedures upon which UKAS accreditation is based. These procedures are approved by the undersigned and must be adhered to as applicable when performing tests qualifying for release for aerospace purposes.

It is also accepted that the company procedures do not override the necessity of complying with the applicable aerospace requirements as published by the CAA or the European Aviation Safety Agency (EASA) from time to time.

#Company name# also agrees to CAA accompanying UKAS assessment managers and their technical auditors from time to time for reassessment or surveillance purposes.

Nominated Site(s)

UKAS Accreditation Ref:

* Signature:

Date:

Name:

Position:

* (Dated signature, legible name and position in laboratory, of individual having legal authority to make the above declaration on the laboratory's behalf, usually the Chief Executive.)

Information to be provided.

INTENTIONALLY LEFT BLANK

Leaflet C-50 UK Certification of Aircraft which are Eligible for the Issue of an EASA or UK National Certificate of Airworthiness

1 Introduction

- 1.1 The purpose of this Leaflet is to provide guidance to applicants regarding CAA requirements that have to be satisfied for the Issue of a Certificate of Airworthiness; it includes procedures covering how to make an application and the subsequent processes.

Whilst covering all aircraft types irrespective of weight, the processes detailed in this Leaflet should not be considered as being definitive. Not all references quoted will apply to every aircraft type.

Reference to Part 21 subpart H, Part M, subpart G (M.A.710), BCAR Section A/B Chapter A/B2-2 and A/B3-2, as applicable, is advised prior to contract/purchase of an aircraft.

2 References

A list of reference publications are detailed in Appendix 1

3 Application and Issue of the Certificate of Airworthiness

This Leaflet is applicable to both new and used aircraft where an application is being made for an EASA or UK national Certificate of Airworthiness.

3.1 Certificate of Registration

The application Form CA1 has to be completed in full and sent together with the appropriate fee to:

Civil Aviation Authority
Aircraft Registration Section
CAA House
45-59 Kingsway
London WC2B 6TE

Tel: +44 (0) 20 7453 6666
Fax: +44 (0) 20 7453 6670
E-mail: aircraft.reg@caa.co.uk

Whilst a UK registration can be allocated following application, evidence of de-registration, or confirmation that the aircraft has never been entered on the civil register of the exporting country is required before it can be issued. The Registration Section will require written confirmation from the previous State of Registry/Exporting Country.

The registered owner should give careful consideration to the timing of the removal of the aircraft from a foreign register. Where an Export Certificate of Airworthiness is required, such a certificate may need to be issued by the exporting State of Registry prior to the aircraft being de-registered.

- NOTES 1:** The Certificate of Registration must be issued before a Certificate of Airworthiness issue can take place.
- 2:** Aircraft must be UK registered for the issue of a Permit to Fly (for EASA aircraft) or for flights under "A" Conditions (for aircraft under national regulations).

3.2 Certificate of Airworthiness

Application for the Issue of a Certificate of Airworthiness (C of A) is made on Form CA3. Particular care must be taken in the completion of all sections of the form to ensure that all the details required are provided, to minimise the processing time taken by the CAA.

Send the completed Form CA3, together with a copy of the Export Certificate of Airworthiness, or other transfer document (if available at time of application) and the correct fee to:

Civil Aviation Authority
Safety Regulation Group
Applications and Approvals Department
Aviation House
Gatwick Airport South
West Sussex RH6 0YR

Tel: +44 (0) 1293 768374
Fax: +44 (0) 1293 573860
E-mail: aanda@caa.co.uk

Upon receipt of Form CA3, the Applications and Approvals Department will carry out an initial technical assessment to determine whether the aircraft is eligible for the issue of an EASA or UK national Certificate of Airworthiness. If the applicant has any doubt on the eligibility of an aircraft to hold a Certificate of Airworthiness, Applications and Approvals Department should be contacted at the earliest opportunity.

Where an Export Certificate of Airworthiness is required, it should not be more than 60 days from the date of issue when received by the CAA. Some regulatory authorities do not issue an Export Certificate of Airworthiness; in such cases the CAA may accept as an alternative:

- a) a valid domestic Certificate of Airworthiness issued within the last 60 days; or
- b) a valid Certificate of Airworthiness together with a written statement signed by the regulatory authority of the exporting state within the last 60 days confirming that the aircraft is in accordance with the TCDS and is in an airworthy condition; or
- c) An EASA form 52; or
- d) an EASA Certificate of Airworthiness issued by another EASA member state and a valid Airworthiness Review Certificate (ARC); or
- e) in the case of a British manufactured aircraft that does not hold a valid C of A, a report from an approved BCARs E3 design organisation for a non EASA aircraft, or a Part M subpart G organisation holding privileges to make C of A and ARC recommendations for an EASA aircraft. In both cases, support from the Type Certificate holder will be required.

Derogations or waivers to requirements issued by the exporting country must be agreed with the CAA in advance.

NOTE: Where an Export Certificate of Airworthiness, or other transfer document has been issued, the original should be available for review at the time of survey.

Delivery flights to the UK may be completed whilst the aircraft is on the foreign register. Aircraft on the UK Register requiring to be flown to a destination in order that it may qualify for the issue of a UK Certificate of Airworthiness may be issued with a Permit to Fly at the discretion of the CAA. Surveyor involvement will normally be required to issue the Permit to Fly for ferry purposes and if this involves travelling abroad, the additional costs incurred will be charged to the applicant (refer to Official Record Series 5, CAA Scheme of Charges).

For new aircraft, classified as Series, delivered directly from the manufacturer, the CAA may at their discretion issue the C of A directly from the Applications and Approvals Department when an agreement is in place between the TC holder and the CAA. Alternatively the CAA may issue ferry Permit to Fly documentation to the foreign regulatory authority to validate on behalf of the UK CAA. The full C of A issue process will then be completed in the UK at an appropriate facility. Request for ferry Permit to Fly documentation must be made on Form CA3 at the time of the application for the C of A.

3.3 **Noise Certification**

The Form CA3 is also the application for the Noise Certificate. The CAA will establish whether the aircraft qualifies for the issue of an EASA or UK national Noise Certificate, which will normally be issued by the Surveyor at the time of C of A issue. If the applicant has any doubt on the eligibility of an aircraft to hold a Noise Certificate, the Applications and Approvals Department should be contacted at the earliest opportunity.

3.4 **Flight Manual (FM), Pilots Operating Handbook (POH) or Owner's Manual (OM) Approval**

When completing the Form CA3 the applicant provides the FM, POH or OM reference number in the appropriate box. It is the responsibility of the applicant to demonstrate that the Flight Manual and any amendments are EASA approved, or for non EASA aircraft, approved by the UK CAA.

The applicant is responsible for demonstrating that any supplements are EASA or CAA approved as applicable.

If there are any queries regarding the approval status of the FM and associated supplements, Applications and Approvals Department should be contacted.

3.5 **Radio Licence and Installation Approval**

All radio equipment installed has to be of an approved type. Details of the equipment approval numbers can be found on the CAA Aircraft Equipment Approval Record System (AEA) on the CAA website. This system gives details of equipment approved by the CAA prior to the introduction of EASA. If the equipment Model No. or Part No. cannot be found on this database, further information on the equipment approval status can be found on either the JAA or EASA websites, for JTSO and ETSO approved equipment.

All radio installations must be approved. The Radio Station Licence must contain details of all airborne radio transmitting systems fitted to the aircraft, e.g. VHF, HF, DME, TXPDR, TCAS, RAD ALT, WX Radar etc. (Note: Emergency Locator Transmitters are not required to be listed on the licence).

An application for a Radio Licence should be made to:

WT Radio Licensing

Surveillance and Spectrum Management

Directorate of Airspace Policy

K6 Gate 6

CAA House

45-49 Kingsway

London WC2B 6TE

Tel: (0207) 453 6529

Fax: (0207) 453 6546

4 Type Certification

For aircraft subject to EU regulation, the type certification standard is that declared by the European Aviation Safety Agency (EASA).

If there are any questions regarding the acceptability of the type certification standard, the Applications and Approvals Department should be contacted.

Refer to CAP 747 Section 1, Part 2 for details of TCDS number and State of Design information.

5 Aircraft and Records Survey

5.1 With the exception of aircraft in the ELA1 category, for all other Used EASA aircraft an appropriately approved Continuing Airworthiness Management Organisation is required to initially perform an airworthiness review, and make a recommendation for the issue of a Certificate of Airworthiness and an Airworthiness Review Certificate to the CAA. To enable the CAA to subsequently sample survey the aircraft and records, the aircraft should be positioned at a suitable maintenance facility with adequate office accommodation. The recommending Continuing Airworthiness Management Organisation shall administer the presentation of the aircraft and records.

In order to allow for possible participation in the initial records review by a CAA Surveyor, the Continuing Airworthiness Management Organisation should notify their assigned CAA Regional Office at least 10 days in advance of the time and location of the airworthiness review.

5.2 Compliance Report for Used Aircraft

a) Used EASA aircraft transferred from within the EU

When a used aircraft with a valid C of A and ARC is transferred from the register of another EU member state, the current C of A and ARC should be presented to the CAA upon transfer of registration. The CAA will issue a new C of A and amend the current ARC with the new registration number, which will remain valid until its expiry date.

NOTE: When transferring within the EU, any Airworthiness Review Certificate issued under national requirements cannot be accepted by another Member State. In such a case a new ARC will have to be issued in accordance with Part M, M.A.901.

b) EASA aircraft imported into the EU from a third country

When importing an aircraft into the EU from a third country, a recommendation for the issue of the C of A and ARC from an appropriately approved Continuing Airworthiness Management Organisation (CAMO) is required, following a satisfactory Airworthiness Review carried out in accordance with Part M, M.A.710.

For aircraft below 2730 kg MTOM and for all Balloons, the airworthiness review may be performed by a Continuing Airworthiness Management Organisation, or where considered appropriate, directly by the UK CAA.

c) Non EASA aircraft requiring a UK national C of A

The accepted maintenance organisation, Licensed Aircraft Engineer (LAE), or, for aircraft above 15,000 kg, the BCAR A8-8 (Group E3) approved design organisation, will be expected to have completed an assessment of the previous records and to certify that a particular aircraft conforms to a standard approved by the CAA.

5.3 **Type Certification Basis**

The aircraft should be assessed to establish that it is in compliance with the appropriate type certification requirements, typically as specified in the applicable Type Certificate Data Sheet (TCDS). This will include the technical characteristics and certification basis.

NOTE: Items marked with an * will require a report, form or documentary evidence supplied to the Surveyor.

5.4 **Flight Test***

Perform Airworthiness Check Flight and if applicable a radio test to the correct schedule, using a pilot accepted by the CAA unless alternative arrangements have been agreed by the CAA. Upon completion and when satisfied, the pilot should sign the Check Flight Schedule.

NOTE: A Check Flight is not required for aircraft imported from within the EU.

5.5 **Mass and Balance***

The following items must be valid:

- a) Weighing Record (record of the weighing and the calculations involved);
- b) Weight and Centre of Gravity Schedule (enables the totally loaded weight and C of G to be calculated);
- c) Weight and Balance Report/Manual required for aircraft above 5700 kg. (Record of loading data essential to enable the particular aircraft to be correctly loaded).

The CAA will normally expect aircraft to be re-weighed prior to the issue of the Certificate of Airworthiness and a weight and centre of gravity schedule to be prepared from that weighing record. If there is technical justification for not weighing the aircraft, there may be discretion to accept the previous weighing record, however this should be agreed with the CAA Surveyor.

5.6 **Airworthiness Directives***

The aircraft and records should be reviewed to establish evidence of compliance and certification of all applicable Airworthiness Directives. An Airworthiness Directive compliance statement should be prepared for the aircraft, engines (including APU if fitted), propellers and equipment.

Compliance should be shown with:

- a) all applicable Airworthiness Directives issued by the States of Design; and
- b) all applicable Airworthiness Directives issued by EASA; and
- c) any CAA Additional Airworthiness Directives (listed in CAP 747).

5.7 **UK Additional Requirements for Import (ARI) - (As applicable)***

The aircraft and records should be reviewed to ensure evidence of compliance with all applicable ARIs, CAA Generic Requirements and JAA/EASA Additional Certification Requirements. (For UK ARIs, refer to CAP 747)

5.8 **Maintenance Requirements**

All maintenance requirements must have been carried out and certified in the applicable aircraft records and a Certificate of Release to Service issued. This may include Scheduled Inspections, Corrosion Prevention and Control Programme, Supplementary Structural Inspection Document tasks and Critical Design Configuration Control Limitations (CDCCL).

Where a used aircraft is being placed on a maintenance schedule or programme, an alignment (bridging) maintenance check may be required. The content of the alignment check, including consideration of previous maintenance standards, previous maintenance programme and any escalations, must be agreed with the CAA Surveyor. For used aircraft below 2730 kg MTOM, being placed on the Light Aircraft Maintenance Schedule or Programme (LAMS/LAMP), an Annual Inspection will normally be required.

All known defects must have been corrected or, when applicable carried forward in a controlled manner.

5.9 **Certification Maintenance Requirements**

Where the type certification process has identified Certification Maintenance Requirements, the aircraft and records should be reviewed to ensure evidence of compliance and certification, at the prescribed intervals and a compliance statement prepared.

5.10 **Airworthiness Life Limitations (Service Life Limits)***

The aircraft and records should be reviewed to ensure the EASA, CAA, State of Design, and Type Certificate Holders recommended life limits have been incorporated into the maintenance programme/schedule. Evidence that the existing life limits have not been exceeded must be established. This also includes the engines, propellers and appliances.

5.11 **Airframe, Engine, APU and VP Propeller Logbooks**

The aircraft, engine, APU, propeller logbooks and appliance historical records must be available to confirm the aircraft's provenance and current status.

Logbooks to meet the ANO requirements must be available and up-to-date.

Owners/operator's who wish to retain records by a means other than log-books will require written approval from the CAA.

5.12 **Modification Records**

All modifications (Major/Minor changes) applied to the aircraft are approved in accordance with Part 21 and adequately recorded. A modification Record Book should be kept for aircraft above 2730 kg MTOM to record all aircraft modifications and repairs. Reference must be made to the approval details of the respective modification or repair (e.g. STC or modification approval reference). For minor changes, this may be the Part 21 subpart J approval reference number.

Modifications relating to Engines and Propellers/APU should be recorded in the applicable logbooks.

5.13 **Previously Applied Repairs**

The aircraft, engine, propeller and appliance records should be reviewed to identify all previous repairs and ensure they comply with approved data recognised by EASA. This can be from the TC STC holder, a Part 21 subpart J DOA, repairs approved under the regulatory oversight of an EU NAA prior to 28 September 2003 or approved by a foreign aviation authority having a bi-lateral agreement with EASA.

5.14 **Cabin Configuration**

Check the current configuration conforms to a recognised approved modification.

- Equipment location and placards
- Seat pitch/aisle width

- Over wing type III and IV exits
- Galleys
- Toilets

5.15 **CAA Specifications**

For non-EASA aircraft, the aircraft and records should be reviewed to ensure compliance with CAA Specifications as applicable. This includes the engines, propellers and appliances. In the case of EASA aircraft, compliance must be shown with the applicable Certification Specifications detailed in the TC/STC.

5.16 **Avionic Issues***

The avionic and electrical equipment installation should be reviewed and the certification and continued airworthiness issues established i.e. electrical load analysis report and software criticality list, maintenance requirements, etc.

NOTE: A detailed electrical load analysis will not be required for single piston engined aircraft or helicopters of 2730 kg MTOM and below, unless approved to fly at night or in IMC.

6 Physical Aircraft Survey

The aircraft survey is intended to establish the condition and conformity of the particular aircraft and will sample various structures/systems and installations together with the associated technical records. When deciding what aspects (areas/zones/systems) to survey on a second-hand/imported aircraft, the previous operating history will be a prime consideration.

For an example of typical survey items, refer to Appendix 2.

7 Operation of the Aircraft

Although not directly related to the issue of the Certificate of Airworthiness, compliance with the applicable operational rules must be established prior to operating the aircraft, e.g. EU-OPS 1, JAR OPS 3, ANO.

Appendix 3 contains typical examples of items that need to be addressed prior to operating the aircraft.

INTENTIONALLY LEFT BLANK

Appendix 1 Reference Documents

- a) (CAP 388, 391, 398, 399, 400 and 408) Log Books – Airframe, Engine, Propellers.
- b) (CAP 393) Air Navigation: The Order and the Regulations. *CAP 393*
- c) (CAP 411) Light Aircraft Maintenance Schedule (Aeroplanes). *CAP 411*
- d) (CAP 412) Light Aircraft Maintenance Schedule (Helicopters). *CAP 412*
- e) (CAP 476) Mandatory Aircraft Modifications and Inspection Summary. *CAP 476*
- f) (CAP 520) Light Aircraft Maintenance. *CAP 520*
- g) (CAP 553) BCAR Section A. *CAP 553*
- h) (CAP 554) BCAR Section B. *CAP 554*
- i) (CAP 731) Approval, Operational Serviceability and Readout of Flight Data Recorder Systems. *CAP 731*
- j) (CAP 747) Mandatory Requirements for Airworthiness. *CAP 747*
- k) (CAP 766) Light Aircraft Maintenance Programme (Aeroplanes). *CAP 766*
- l) (CAP 767) Light Aircraft Maintenance Programme (Helicopters). *CAP 767*
- m) Official Record Series 5, CAA Scheme of Charges. *ORS 5*
- n) Type Certificate Data Sheets – available for download from various National Aviation Authority websites, including the CAA, FAA and EASA.
- o) CAA Specifications.
- p) EU OPS 1/JAR-OPS 3.
- q) CS-ETSOs.
- r) Additional National Design Requirements (JAA Administration and Guidance Material).
- s) EASA Part M subpart G.
- t) EASA Part 21 subpart H.
- u) EASA Part 21 subpart P.

Many items are available on the CAA website at www/caa/co/uk/XXXX (insert reference shown in italics in above list to go directly to that publication). Details of Log Books and a link to the CAA's printed copy supplier is also provided.

INTENTIONALLY LEFT BLANK

Appendix 2 Typical Survey Items

The aircraft survey is intended to establish the condition and conformity of the particular aircraft and confirm there are no inconsistencies between the aircraft and the documented review of the records and that there are no evident defects that have not been addressed. It will sample various structures/systems and installations together with the associated technical records. When deciding what aspects (areas/zones/systems) to survey on a second-hand/imported aircraft, the previous operating history will be a prime consideration. The following are examples of items, which may be sampled by the Surveyor during the survey:

1 Structures and Systems including Engines, Propellers and Appliances

- Condition and conformity
- Repainting
- Repairs

2 Flight Manual

The flight manual contents should be checked to confirm concurrence between the aircraft configuration and Declaration of Flight Manual Standard (DFMS) and if applicable the revision status of any additional supplements.

3 Cabin Configuration

- Compliance with approved drawing
- Minimum space for seated passengers
- Access to exits and emergency exits
- In Flight Entertainment (IFE) installations
- Galley and Lavatory compartments

4 Manufacturer's Data Plates

Check details on data plates are correct.

5 Nationality and Registration Marks

Fireproof plate/Aircraft exterior.

6 Compass Correction

Cards installed and valid.

7 Exit and Break-in Markings

- Applicable exit and "break-in" markings
- Door surround markings

8 Internal and External Placards and Markings

- Cabin placards
- Cockpit placards and instrument markings
- External placards

9 Mandatory Requirements

- Flight Manual
- Air Navigation Order
- Modifications (including minor changes and STCs)
- Airworthiness Directives
- Type Certificate Data Sheets/AAN
- CAA Specifications
- Certification Maintenance Requirements

10 Aircraft Records

- All log books
- Work packages
- Technical Log
- Life Item Records / Component Log Cards

11 Emergency Equipment

Equipment compliance checked to approved drawing.

12 Operational Requirements (Commercial Air Transport)

- JAR-OPS
- EU OPS
- ANO
- JAR-26.

Appendix 3 Operation of the Aircraft

The following items are not directly related to the issue of the Certificate of Airworthiness. They must however be addressed prior to flight, according to the purpose for which the aircraft is used: Private, Public Transport (Commercial Air Transport), Aerial Work (Commercial Operations other than Commercial Air Transport).

1 Approved Maintenance Programme/Schedule

The owner/operator of the aircraft is responsible for the continued airworthiness of the aircraft, which includes maintaining the aircraft to the approved maintenance schedule/programme.

NOTE: If the aircraft type is new to the operator it will normally be expected that the maintenance schedule/programme (task/check frequencies) will be based upon the Maintenance Review Board Report (MRBR), Maintenance Planning Document (MPD) or equivalent documents. Movement away from the scheduled tasks and intervals will only be considered when the operators in service experience/reliability monitoring data is available to support the change.

Ensure the maintenance programme/schedule has been approved and is applicable for the particular aircraft, or that an amendment has been raised to add the aircraft into an existing maintenance programme / schedule.

Avionics and operating approvals equipment should be adequately addressed, i.e. maintenance instructions (or equipment) systems installed under STC or other modification approval. Such instructions will not always reside in the MPD; it is advised that the certification basis for the equipment be reviewed to identify the continued airworthiness instructions.

2 Certificate of Maintenance Review (CMR) (Non-EASA Aircraft only)

A CMR is required by the ANO and is applicable to aircraft with a C of A in force and used for Public Transport and Aerial Work not operated on an EU-OPS 1 or JAR-OPS AOC.

3 Technical Log

A Technical Log is required for aircraft used for Commercial Air Transport and Commercial Operations. The Technical Log should be to an appropriate standard for the aircraft type.

4 Equipment

The aircraft and records should be reviewed to ensure compliance with the ANO, EU OPS 1 or JAR-OPS 3 standard for operational equipment. It is the owner/operator's responsibility to ensure that CAA, JAA or EASA approves all equipment fitted to the aircraft. This responsibility extends to establishing that any limitations or restrictions mentioned within the CAA Approval or TSO, JTSO, ETSO are understood and complied with.

NOTE: For EU OPS 1 or JAR OPS 3 the operator should prepare a compliance statement to demonstrate how the applicable elements of subparts K and L are being complied with.

5 Additional Airworthiness Requirements for Operations

The operator should prepare a compliance statement to demonstrate how the applicable requirements of JAR-26 are being complied with. Examples being Lavatory Fire Protection, Internal Emergency Lighting and Emergency Exit Markings.

6 Operational Approvals

The aircraft and records should be reviewed to ensure compliance with operational approvals as appropriate:

- Reduced Vertical Separation Minima (RVSM)
- Extended Twin-engine Operations (ETOPS) / Long Range Operations (LROPS)
- All Weather Operations (AWOPS) / Auto land Category
- Minimum Navigation Performance Specification (MNPS)
- Required Navigation Performance Specification (RNP)
- ECAC Airspace BRNAV / P-RNAV6.7

7 FDR and CVR Calibration/Readout

7.1 FDR

The operator/applicant should provide a compliance statement that demonstrates the following:

- A Data Frame Layout Document (DFL) is available for the FDR system.
- Conversion Data (to enable translation of FDR data to engineering units) is available for the FDR system.
- Procedures are in place to provide the DFL and Conversion Data to the appropriate readout facility.
- The Aircraft Approved Maintenance Schedule / Programme includes a list of tasks specified by the TC/STC holder to ensure the continued serviceability of the FDR system.
- The FDR Readout from a representative flight, conducted immediately prior to C of A issue, has been evaluated to ensure that the FDR system is functioning correctly.

NOTE 1: Where an operator experiences a delay such that the results of the read out are not available for analysis at the time of C of A issue, the responsible CAA Regional Office should be contacted to agree a specified time scale for its completion.

2: Irrespective of the originating source of the aircraft, the FDR system is required to meet the UK operational rules.

3: For further information, refer to CAP 731.

7.2 CVR

The operator will need to arrange for a recording from the CVR to be evaluated for acceptable performance. In addition, periodic maintenance checks and evaluation of recordings will need to be included in the approved maintenance Schedule / Programme.

Leaflet C-60 Issue of an EASA Permit to Fly to UK Registered Aircraft Temporarily Unable to Hold a Certificate of Airworthiness or Restricted Certificate of Airworthiness

1 Introduction

- 1.1 This Leaflet has been issued to advise owners/operators of aircraft, appropriately approved Continuing Airworthiness Management Organisations (CAMOs), design, maintenance and production organisations and licensed aircraft maintenance engineers, of the rules and the associated processes for application, approval and issue of EASA Permits to Fly.

2 Applicability

- 2.1 This Leaflet is applicable only to UK-registered aircraft which are required to hold a Certificate of Airworthiness or Restricted Certificate of Airworthiness, issued by the UK CAA under Commission Regulation (EC) No. 748/2012 (Part 21), but are temporarily unable to maintain the validity of the certificate.
- 2.2 This Leaflet is not applicable to aircraft engaged in military, police, customs or similar services, aircraft classified as being within the criteria of Annex II to Regulation (EC) No. 216/2008, or aircraft that are only eligible for a UK National or EASA enduring Permit to Fly.

NOTE: Part 21 Subpart P allows for EASA Permits to Fly to be issued for certain purposes by organisations holding appropriate privileges under Part 21, Subparts G and J. EASA Permits to Fly issued by such organisations fall outside the scope of this Leaflet.

3 Circumstances under which an EASA Permit to Fly may be Required

- 3.1 Regulation (EC) No. 748/2012 (as amended), Subpart P, allows for the issue of an EASA Permit to Fly to an EASA aircraft for particular purposes. These purposes include allowing an aircraft to fly when:
- a) the Certificate of Airworthiness is temporarily invalid, for example, as the result of damage; or
 - b) test flying is required to support approval of the design of the aircraft or a modification/repair to an aircraft; or
 - c) the aircraft does not or has not been shown to meet the requirements for a Certificate of Airworthiness, but is capable of performing safe flight under specified conditions.

The above list is not exhaustive. A full list of the purposes for which an EASA Permit to Fly may be issued is given in the amendment to Part 21, Subpart P, paragraph 21A.701.

4 How to Determine whether or not a Permit to Fly is Required

The flowchart in Figure 1 will assist the determination of whether or not a Permit to Fly is required for your aircraft.

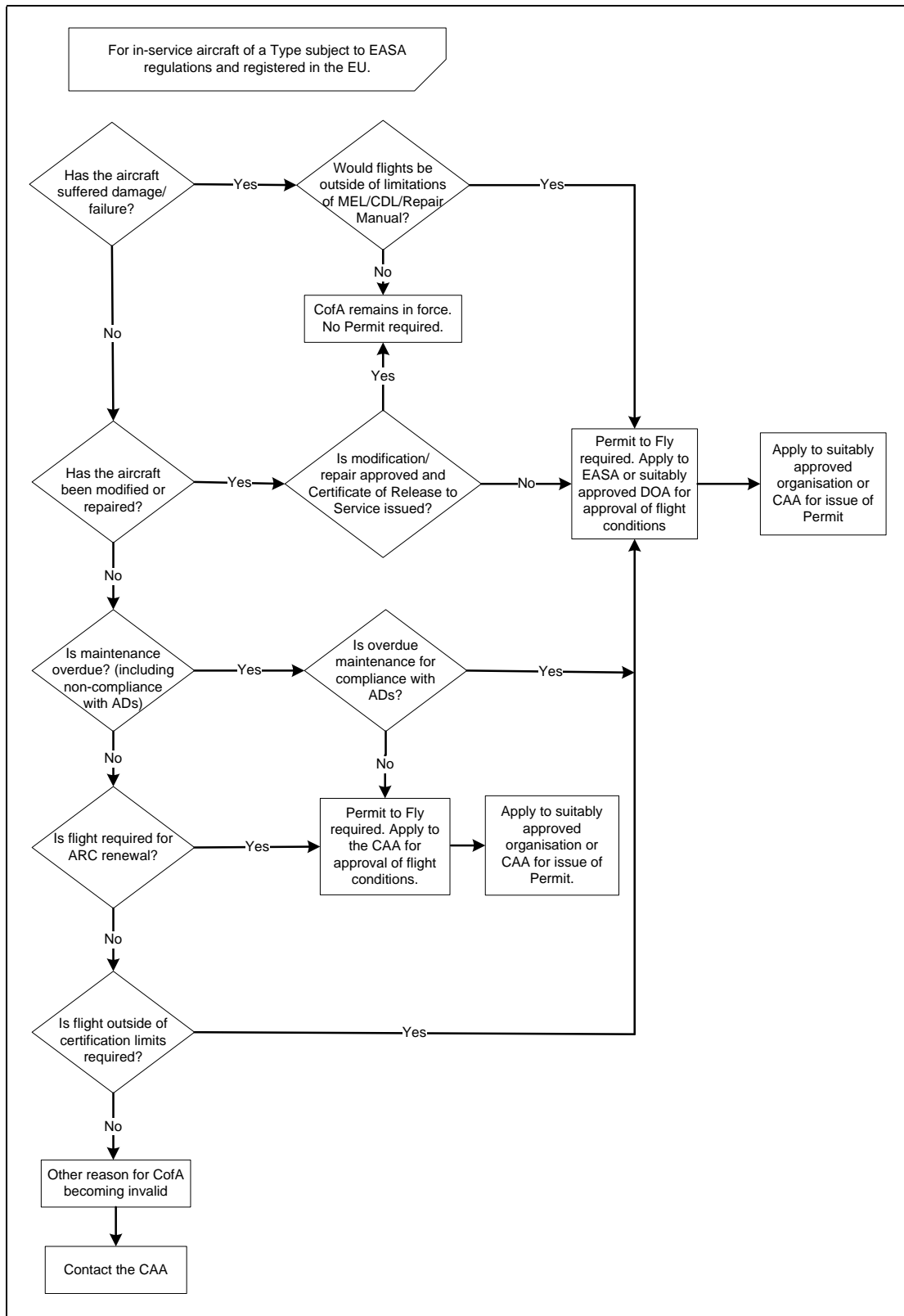

Figure 1 How to determine whether or not a Permit to Fly is required for your aircraft

5 Process for the Issue of an EASA Permit to Fly

- 5.1 There are two separate elements that lead to the issue of an EASA Permit to Fly:
- a) the approval of the Flight Conditions; and
 - b) the issue of the EASA Permit to Fly.
- 5.1.1 The approval of Flight Conditions is broken down into two sub-categories;
- i) Safety of the Design;
 - ii) not relating to the Safety of Design.

6 The Approval of Flight Conditions

6.1 Safety of Design Related Flight Conditions

- 6.1.1 Where the circumstances of the flight and the necessary Flight Conditions are related to the safety of design, the Flight Conditions for an EASA Permit to Fly outlining the basis upon which the flight can be conducted can only be approved directly by EASA, or by an organisation holding an EASA Part 21 Subpart J Design Organisation Approval (DOA) with a specific privilege to approve Flight Conditions.

NOTES: 1 Application to EASA is made on EASA Form 37, which may be downloaded from the EASA website. This form includes an appendix (Form 18b) where the Flight Conditions that will be finally approved by EASA are defined.

2 An application is not required to EASA if the approval of Flight Conditions is to be carried out by an organisation holding a DOA with the relevant privileges.

Once the Flight Conditions have been approved by EASA or a suitably approved design organisation, the Permit to Fly may be issued by the CAA or an appropriately approved Continuing Airworthiness Management Organisation (CAMO). Refer to paragraph 7.

6.2 Not Relating to the Safety of Design Flight Conditions

- 6.2.1 In cases where the configuration of the aircraft and circumstances of the flight are not related to the safety of design, the CAA is required to approve the Flight Conditions.
- Examples of where the non-compliance with the regulations is not related to the safety of the design of the aircraft are:

a) Positioning flight for maintenance purposes with an invalid Certificate of Airworthiness or when a maintenance check is overdue.

NOTE: This does not include flights where there is a non-compliance with an Airworthiness Directive as this would, in most cases, be considered as a design related and should be referred to EASA or an appropriately approved DOA. Refer to paragraph 6.1.

b) Flight to a place of storage or to a place where maintenance/painting is to be carried out.

c) Flights necessary for the issue of a Certificate of Airworthiness or Airworthiness Review Certificate of an aircraft of an approved type design.

d) Delivery or export of a new aircraft where the design is approved.

This is not an exhaustive list but covers the majority of circumstances where the CAA can approve the Flight Conditions associated with the issue of an EASA Permit to Fly.

- 6.2.2 An application for the approval of Flight Conditions not relating to the safety of Design must be made to the CAA using form SRG 1728a (CAA Form 37). In addition the

applicant must submit an SRG 1728b form (CAA Form 18b) specifying and justifying the proposed non-design-related Flight Conditions. This should include any supporting data defining the configuration of the aircraft, any Flight Manual references or supplements, where applicable.

Following approval of the Flight Conditions, the EASA Permit to Fly may be issued by either the CAA, or an appropriately approved CAMO. Refer to paragraph 7.

NOTE: The forms referenced in the paragraph above are subject to change. The latest application form(s) can be downloaded from the CAA website at: www.caa.co.uk/forms.

7 Application for an EASA Permit to Fly

7.1 Application to the CAA for the Issue of an EASA Permit to Fly

7.1.1 An application to the CAA for the issue of an EASA Permit to Fly must be made to Applications and Approvals by submitting a completed SRG 1733 form (CAA Form 21) together with the relevant fee (see paragraph 12.3 of this Leaflet).

NOTE: The form referenced in the paragraph above is subject to change. The latest application form can be downloaded from the CAA website at: www.caa.co.uk/forms.

7.2 Application to a CAMO for the Issue of an EASA Permit to Fly

7.2.1 A CAMO which is approved to issue an Airworthiness Review Certificate for the particular aircraft type, may additionally be approved to issue a Permit to Fly in accordance with the provisions of Part M, M.A.711(c), subject to the following:

- a) For aircraft used in Commercial Air Transport, and aircraft above 2730 kg MTOM, except balloons, the Permit to Fly can only be issued when the aircraft is in a controlled environment and the Permit is issued by the CAMO managing the aircraft.
- b) For aircraft not involved in Commercial Air Transport of 2730 kg MTOM and below, and balloons, any appropriately approved CAMO may issue a Permit to Fly.
- c) For aircraft used in Commercial Air Transport, and aircraft above 2730 kg MTOM, that are not in a controlled environment, a CAMO cannot issue a Permit to Fly. Therefore, application must still be made to the CAA.

7.2.2 The application to the approved CAMO for the issue of an EASA Permit to Fly must be made in a form and manner established by the CAMO.

7.2.3 An application must include the approved flight conditions either: an EASA Form 18b (approved by EASA), an EASA Form 18a or equivalent (approved by an appropriately approved Part 21 DOA) or a CAA form SRG 1728b (approved by the CAA). The CAMO will be unable to issue an EASA Permit to Fly until they are in receipt of the appropriately approved Flight Conditions.

7.2.4 Where the CAMO is acting on behalf of, or under contract to, the owner/operator, they may apply for the approval of flight conditions.

8 Issue of the Permit to Fly

8.1 Issue of the Permit to Fly by the CAA

- 8.1.1 The CAA shall issue an EASA Permit to Fly when in receipt of a valid application, when the Flight Conditions have been approved, and when satisfied that the aircraft is safe to carry out the intended flight or series of flights.

The EASA Permit to Fly will specify or reference the Flight Conditions as approved by EASA, the Part 21 DOA, or the CAA, as applicable.

- 8.1.2 The CAA reserves the right to carry out a survey of the aircraft and/or associated records, and/or to require or perform a test flight to verify the conformity of the aircraft.

8.2 Issue of an EASA Permit to Fly by a CAMO

- 8.2.1 The CAMO may only issue an EASA Permit to Fly when:

- a) it is eligible to issue the Permit to Fly; and
- b) it is satisfied that the Flight Conditions have been established and approved; and
- c) it has verified that the aircraft conforms with any specified Flight Conditions; and
- d) it has confirmed that any required maintenance defined in the Flight Conditions has been carried out.

9 Compliance with the Conditions of an EASA Permit to Fly

- 9.1 Prior to a flight being made with an EASA Permit to Fly in force, a Certificate of Release to Service (CRS) shall be issued in accordance with Commission Regulation (EC) 2042/2003 Annex I (Part M), M.A.801, Annex II (Part 145). The CRS must contain details verifying that the aircraft conforms with the conditions specified on the Permit to Fly and has been inspected and is fit for the intended flight.

9.2 Example of Flight Condition, for entry on a Permit to Fly:

A Certificate of Release to Service (CRS) shall be issued verifying that the aircraft conforms with the conditions specified on the Permit to Fly, the Form 18b (or 18a) and any associated documents, and that the aircraft has been inspected and is fit for the intended flight.

10 Validity of an EASA Permit to Fly

- 10.1 An EASA Permit to Fly is valid in the United Kingdom subject to the aircraft remaining in compliance with the approved Flight Conditions and the applicable rules of the air. An EASA Permit to Fly is valid in all EU Member States, but may be subject to additional National airspace use access and use restrictions. It is the responsibility of the aircraft operator to ensure any applicable national regulations are complied with. The validity of an EASA Permit to Fly outside of the EU is subject to the National Regulations of the State(s) in which the flight is to take place. Applicants should consult with the relevant National Aviation Authorities in case of doubt.

11 Urgent Operational Need

- 11.1 There may be design related cases **where an application has been made to EASA** for the approval of Flight Conditions, but the need to move an aircraft is due to

unforeseen urgent operational reasons (primarily damaged aircraft recovery for repair) and where EASA is unable to provide a response within appropriate timeframes. In such cases, where it is accepted that there is an urgent operational need and evidence has been provided that EASA is not able to support the required timescales, the CAA may consider issuing an exemption to the organisation issuing the Permit to Fly from the requirement for the Flight Conditions to be approved by EASA. The CAA must be satisfied with the safety of the proposed flight and will carry out essentially the same investigation as EASA. If the CAA is satisfied that the proposed Flight Conditions are appropriate and that the flight can be made safely, an exemption may be granted and a Permit to Fly issued. The CAA will require the same substantiating data and proposed Flight Conditions that were submitted to EASA to be provided, before considering an exemption request.

NOTE: Under these circumstances, it is normally expected that Flight Conditions and substantiating data will originate from the Type Certificate Holder.

- 11.2 The applicant will be required to pay any additional direct CAA costs incurred in respect of the technical investigation carried out leading to the issue of an exemption and, where appropriate, the issue of an EASA Permit to Fly.

12 References

- 12.1 Ongoing developments in this area will be notified through the Permits to Fly pages of the CAA website at the following address: www.caa.co.uk/EASAPermits.
- 12.2 The text of the regulations referenced in this Leaflet can be obtained from the EASA website at the following address: www.easa.europa.eu.
- 12.3 The fees for these activities are defined in the CAA Scheme of Charges document Airworthiness, Noise Certification and Aircraft and Aircraft Engine Emissions which can be viewed on the CAA website at the following address: www.caa.co.uk/ORS5.
- 12.4 The forms referenced in this leaflet can be obtained from the CAA website at www.caa.co.uk/publications or the EASA websites www.easa.europa.eu as appropriate.

Leaflet C-70 Issue of a Certificate of Airworthiness for Duplicate Sailplanes in accordance with Regulation (EC) No. 216/2008

1 Purpose and Scope

- 1.1 To qualify for an EASA Certificate of Airworthiness, sailplanes must meet the requirements of Regulation (EC) No. 1702/2003 Annex Part 21, which states that all affected UK registered sailplanes must conform to a Type Design Approved by EASA. This procedure is for the owners of those sailplanes, which were modified or repaired prior to 28 September 2008, that are identified as potentially not meeting the requirement of conforming to the approved Type Design because the sailplane's identity (manufacturer's serial number) or origin is in doubt.
- 1.2 Since 28 September 2008, all EASA aircraft must comply with Regulation (EC) No. 2042/2003 Annex I (Part M), with respect to continuing airworthiness. To continue to qualify for an EASA Certificate of Airworthiness they must continue to meet the requirements of EASA Part 21 (Annex to Regulation (EC) No. 1702/2003), in particular, to the requirements for repairs and modifications to the airframe and its component parts. Sailplanes requiring repair following major damage post 28 September 2008 are covered by CAP 562 Leaflet C-130.

2 Procedure

- 2.1 Since the beginning of 2008, as the UK gliding community moved to register their aircraft and the transition to an EASA Certificate of Airworthiness, evidence emerged via the CAA's Aircraft Registration Section that a number of sailplane owners applying for registration had a duplicate or non-standard aircraft manufacturer's serial number. In the majority of these cases, it was unclear as to the true identity or origin of the aircraft. As a consequence, the transition to an EASA Certificate of Airworthiness would not be possible without further investigation.

NOTE: Duplicate Sailplane – where two sailplanes of the same type designation exist with identical serial numbers. Generally, a second sailplane has been "created" from parts around a repaired fuselage, and given the serial number of the repaired fuselage.

Non-standard aircraft manufacturer's serial number – the serial number is not of the same format as defined by the manufacturer for the aircraft type.

- 2.2 The CAA is aware that these aircraft were previously accepted under the British Gliding Association (BGA) governance, as they were considered (by the BGA) to comply with a standard that ensured an adequate level of safety. In view of the findings of the EASA Airworthiness Review Team (ART) visit of January 2007, and their conclusion that modifications and repairs were carried out in a manner consistent with the way such work is carried out in other Member States, the CAA will accept the modifications and repairs that were carried out on sailplanes prior to 28 September 2008. Owners should ensure all the relevant paperwork is contained within the aircraft's historical records. The CAA or EASA may require reference to these records in establishing the identity and origin of a sailplane. Owners should also be in possession of the appropriate aircraft documentation and manuals, which should include a current and up to date Flight Manual.

- 2.3 However, the question of sailplane identification still remains. Owners will be able to apply for an EASA Certificate of Airworthiness, but to qualify, it will be the responsibility of the owner to demonstrate that their aircraft conforms to the applicable Type Design. In particular, the aircraft's identity must be established by the presence of the original manufacturer's data plate fitted to the fuselage of the sailplane.

NOTE: The identity of an aircraft is provided by the manufacturer's data plate, which should include the manufacturer's name, the product designation, and manufacturer's serial number. ICAO states that 'though the aircraft will retain the unique serial number recorded on its data plate throughout, many of its component parts and assemblies, including some significant structural items, may be replaced during its operational life', and this has been reflected by EASA in Part 21 Subpart Q.

- 2.4 Where the repairs and replacements have been carried out under the control and oversight of the manufacturer and the sailplane has been given a new fuselage and a new serial number, the sailplane in this instance, should be given a new registration and will qualify for an EASA Certificate of Airworthiness.

- 2.5 Sailplanes that have been managed within the BGA scheme of airworthiness management, that have a duplicate or non-standard manufacturer's serial number, will not be eligible for a standard EASA Certificate of Airworthiness. In such cases, it has been agreed with EASA that the sailplane may be eligible to be issued with an EASA Restricted Certificate of Airworthiness, when the provenance of the aircraft has been established and recorded in an SAS (Specific Airworthiness Specification) drawn up by EASA.

- 2.6 It is the responsibility of the owner to ensure that they can provide the necessary documentation required to support an application for an SAS. Applications should be made directly to EASA. The investigation and publication of the SAS will be subject to EASA fees and charges.

- 2.7 Applications should be made in writing and addressed to:

Certification Manager General Aviation
EASA – European Aviation Safety Agency
Postfach 10 12 53 D-50452
Cologne
Germany

Leaflet C-80 Steep Approaches

1 Introduction

- 1.1 The purpose of this Leaflet is to provide guidance material to explain the Airworthiness and Operational Requirements for Steep Approach Operations conducted by aeroplanes for which the certification and approval remains the responsibility of the CAA. For all other aeroplanes, guidance concerning the applicable requirements should be obtained from EASA.
- 1.2 Few aerodromes in the UK require a steep approach capability, hence there has not been a need for a comprehensive statement of the CAA's requirements for this type of operation. However, one such aerodrome, London City Airport, does require a steep approach and can only accept those aeroplanes that are approved for such operations. The glideslope angle at the aerodrome was originally $7\frac{1}{2}^\circ$, but has been reduced to $5\frac{1}{2}^\circ$. Together with an increase in runway length to 1199 metres (3934 ft), this represents a greater operating flexibility than before and it is recognised that a number of operators may accordingly wish to investigate the feasibility of operating their aeroplanes at this aerodrome.
- 1.3 This Leaflet is therefore intended to indicate areas of concern, and to provide guidance on how an application for steep approach approval should be undertaken. It is not specific to London City Airport, but applies to any circumstance where steep approaches are required.

2 Definition of Steep Approaches

- 2.1 The vast majority of approaches are flown at a glideslope angle of 3° . Angles up to $3\frac{1}{2}^\circ$ are occasionally found but are nevertheless considered to be routine and within the capabilities of any certificated aeroplane. Approach angles greater than $3\frac{1}{2}^\circ$ but less than $4\frac{1}{2}^\circ$ are unlikely to produce significant problems in normal operations, but operators which encounter such procedures should consult with the aeroplane manufacturer to satisfy themselves that the performance and handling characteristics are satisfactory at this angle. It is generally accepted internationally that approach paths of $4\frac{1}{2}^\circ$ or greater constitute steep approaches for which specific airworthiness and operational approval is required.

3 Promulgation of Approval

- 3.1 For UK registered aeroplanes, airworthiness approval to make steep approaches will appear in the Flight Manual. This will specify a maximum approach angle permitting the use of steep approach procedures up to that angle. If no such approval is contained in the Flight Manual, then it must be assumed that the aeroplane is not approved to make steep approaches.
- 3.2 Clearance of a particular type of aeroplane will not automatically permit all individual examples to operate to the approved angle, because such an authorisation might require the modification of existing equipment, such as Terrain Awareness Warning System (TAWS), autopilot and flight director computers. It will be the operator's responsibility to determine the eligibility of a particular aeroplane to operate to the approved standard. The type approval issued by the CAA will be considered proprietary to the manufacturer. This will ensure that the ongoing airworthiness

responsibilities remain with the appropriate organisation. Foreign-registered aeroplanes will also be expected to have the appropriate clearance, the responsibility for which lies with the Regulatory Authority of the State of Registration.

NOTE: UK operators will also be required to obtain operational approval from the CAA Flight Operations Inspectorate Department before services are permitted to begin.

- 3.3 All steep approaches will require approach path guidance of a type which must be acceptable to the CAA. For visual approaches, weather minima of 500 ft or 1000 ft cloud base for propeller-powered and turbojet-powered aeroplanes respectively, and 2 nautical miles visibility will be required. This will allow adequate preparation time at the minimum height between visually locating the runway and intercepting the glideslope.

4 Application for Steep Approach Approval

- 4.1 Applications for steep approach approval should ideally be made by the manufacturer and addressed to the Airworthiness Evaluation and Surveillance Department of the Airworthiness Division. Operators wishing to obtain steep approach approval for their aeroplanes may apply directly, but should first seek the support of the manufacturer, since CAA flight test evaluations are normally constrained to the various flight envelope parameters that have already been explored and cleared. In any case, the CAA would generally seek the manufacturer's agreement before undertaking an evaluation.

5 Additional Considerations Associated with Steep Approach Approval

- 5.1 Speed and flight path control become more demanding with increasing approach angle. The ability to track a steep approach path, and especially to regain the glideslope from above, depends upon the aeroplane possessing adequate residual throttle movement to make the necessary flight path corrections, and will receive close attention during certification.
- 5.2 Applications for steep approach approval should specify the configurations required to be evaluated, i.e. all-engines-operating or one-engine-inoperative, with or without flight director and autopilot. Any approval which utilises existing equipment such as autopilot or flight director will require a re-evaluation of those systems to ensure compatibility in the new operating environment. For example, TAWS boundaries would need to be checked and in some cases may require modification.
- 5.3 An aeroplane type may optionally be cleared for a one-engine-inoperative steep approach and landing. Nevertheless in all cases consideration must be given to the procedures to be adopted in the event of an engine failure after the commencement of the approach. This should include assessment of the go-around capability in the landing configuration.
- 5.4 A common misunderstanding is that a steep approach automatically allows a reduced scheduled landing distance. This has never been the case. Short field landing performance is a separate certification issue, irrespective of the type of approach. If it is required CAA performance specialists will need to be consulted, and additional work (which may include flight measurement) carried out in order to produce the necessary Flight Manual charts.

6 Structural Considerations

- 6.1 The effects of the probability of occurrence of increased rates of descent and thus normal acceleration values during landing from steep approaches must be taken into account.

7 Evaluation for Approval

- 7.1 The CAA will require to evaluate the aeroplane to address those items discussed in paragraph 5 above. It is not possible to specify a flight test schedule that would be applicable to all certifications as it would vary with each individual type and extent of approval that was sought, but in all cases flight tests at the limiting values of weight and centre of gravity position will be required. To facilitate this evaluation, these flights will need visual approach path guidance set up at the nominated glideslope angle, and additionally at a steeper angle not less than 2° greater than the nominal angle. Flight testing at this steeper angle is intended to evaluate the ability to regain the glideslope following an inadvertent deviation, and to simulate the effects of an approach with a tailwind. If flight director or autopilot approval is sought, then an ILS calibrated at the nominated angle will also be required.

8 Further Information

- 8.1 Enquiries regarding steep approaches should be addressed to:

Civil Aviation Authority
Safety Regulation Group
Aviation House
Gatwick Airport South
West Sussex RH6 0YR.
Telephone: +44 (0) 1293 567171 (Switchboard).

- 8.2 Specific questions relating to applications for Steep Approach approval, including technical queries, should be addressed to the Airworthiness Evaluation and Surveillance Department. Operational approval queries should be addressed to the Flight Operations Inspectorate Department.

INTENTIONALLY LEFT BLANK

Leaflet C-90 Computer Control – Records and Programmes

1 Introduction and Purpose

- 1.1 Increasingly, the CAA are being asked by approved organisations if the CAA accepts the computerisation of aircraft records, maintenance programmes, stock control records etc., as an alternative to the traditional 'hard copy' documents. The purpose of this Leaflet is to provide guidelines and general information to assist in responding to these questions.

2 References:

- 2.1 Air Navigation Order 2009 (as amended)

3 Legal Requirements

- 3.1 It has been established that the CAA may accept computerised records where it has satisfied itself that the computerised record will provide storage, preservation and retrieval to the same level as would have been achieved by hard copy records. The CAA acceptance of computerised recording does not normally exempt the operator or company from complying with the conditions of Articles 150, 151, 156, 157, 158 and 159 of the Air Navigation Order 2009 (as amended).

4 Scope of Computer Function and CAA Assessment

- 4.1 The scope of the computer function will determine the extent to which the CAA will be involved in establishing satisfaction with the proposal. Total maintenance control programmes will obviously need more involvement than simple stock control record systems used by (say) material distributors. The assessment guidelines in paragraph 4 of this Leaflet are addressed to the more complex proposals, as indicators of the type of questions that should be considered.

5 Assessment Guidelines

- 5.1 Identify the type of computer and try to ascertain the degree of confidence that the company personnel place on the system from practical experience. Identify the extent of the intended use for both CAA and non-CAA functions. It is common for organisations to introduce computerisation for simple tasks, using only a fraction of the computer capability. As experience is gained and the potential is realised, the user tends to incorporate additional functions. These functions can extend beyond the initial proposals for CAA purposes and encroach on areas not originally assessed. Therefore, impress upon the Company that any programme extension of CAA functions must be discussed with the CAA before they are incorporated.
- 5.2 Power supply and memory preservation. Current computer technology usually includes a system to detect voltage variations and to automatically transfer to a back-up power system when necessary. Earlier, and cheaper, computers can suffer memory loss due to power interruptions. Ensure that memory and function will be preserved in the event of power interruption. Check if there is a standby tape system which can be used to recover corrupted information.

- 5.3 Dumping function. Some computer systems include a 'dumping' function. This is a procedure whereby a tape, or disc, which can be used for more than one programme, has the information relating to one specific programme 'dumped' (consolidated) onto another tape or disc for storage purposes. Where a dumping function is incorporated, ensure that the procedure is described in the operation manual (paragraph 5.1 refers), and that it is appreciated by the operator that incorrect procedures can result in compromised programmes.
- 5.4 Data entry and verification. The method by which data is transferred from either a paper based system or previous computer system, should be defined. Additionally, the process by which verification of data entered onto the system will need to be demonstrated through a representative check sample. Data relating directly to safety critical aspects such as Certification Maintenance Requirements (CMRs) or Airworthiness Directive compliance may require up to 100% sampling to ensure no transcription errors are inadvertently loaded into the system. The ongoing process by which the accuracy of data is maintained and overseen should also be considered and incorporated into the company procedures.
- 5.5 Computer access and security. Some computer networks will have multi-terminal sites. Whilst the computer information may be readily available to all users, it is important to ensure that only authorised persons have the access which will enable alterations and deletions to be made to the programme. In some systems this is accomplished by the authorised person keying in a personal identification code. Other systems respond to the insertion of an identification card. Try to beat the system and gain access as an unauthorised operative.
- 5.6 Record of amendments to stored information. Some systems retain for recall the total history of all inputs. Thus, if a component was programmed to be 'called off' at 10,000 hours and was changed because of defect at 8,000 hours, the complete history including the instruction to delete the 10,000 hour entry would be retained in the data bank. Other systems will only retain the last information fed and erase the back history. As a further example, consider a Service Bulletin. Initially perhaps only the repetitive inspection part of the bulletin needs to be accomplished. Subsequently if the terminating modification part of the SB is accomplished, deleting the necessity for repetitive inspection, will this terminating action delete all reference to previous inspections? This type of information needs to be considered when evaluating a computerised maintenance programme.
- 5.7 When evaluating a system which will be used by, say, a Material Distributor, consider if the computer will also be used to produce the Approved Certificate. If this is the case, then recognition must be made of the requirement for consecutive serialised numbers to be controlled and allocated to each certificate.
- 5.8 Software compatibility should be verified prior to implementation, although this may need to be confirmed through a process of testing or consultation with specialists. Some software packages achieve only limited interchangeability and may potentially inhibit data retrieval or even result in a corruption of the presentation of information required.

6 Bringing the System on Line

- 6.1 Before bringing a system on line, it is essential to ensure that operations manuals are available to the proposed operatives.
- 6.2 The computer manufacturer's operations manual should be supplemented by a Company Manual which describes:

- a) The main functions of the proposed system. Under this heading would be such subjects as Aircraft Maintenance files, Removal and Installation of Components, Records of Inspections and Flying hours, Component purchase orders or despatch for overhaul, Stock records etc.
 - b) The company procedures for interrogation and enquiry. This part should also identify the persons authorised to make changes to the programme, and a brief description of the security control which ensures that unauthorised inputs will not be accepted.
 - c) A flow chart of the various functions. Check who within the Company, does what with selected parts of the programme.
 - d) Training arrangements for operatives and authorised personnel.
- 6.3 The normal testing period for a computer control system has been established by the CAA as six months. During this period the traditional hard copy documentation is run in parallel with the computer system. This enables checks to be made of the validity of the programmed information.
- 6.4 During the testing period the CAA requires a 'Problem Log' to be maintained. This should be a register (not loose-leaf), in which all problems, subsequent action and solutions are entered. This procedure tests the validity of the Company Manual (Paragraph 5.2 refers).
- 6.5 In the case of an Approved Organisation, the Company Manual information should be incorporated into the Company Exposition.

7 Conclusions

This Leaflet is not a training document, neither does it attempt to define the common terms used in the computer industry. Computer abilities and computer deficiencies can vary considerably between makes and models, and these can be exacerbated by the human abilities and deficiencies of the operator. The material contained in this Leaflet should enable staff to identify potential problems, and also to ask the right questions. These questions will test the verity of any claim by the applicant 'that the computer system will maintain a level of confidence at least equal to that provided by the traditional hard copy records'. If the Surveyor can satisfy himself that this criteria can be met, the system is probably acceptable. If doubts exist then reference should be made to the Airworthiness Evaluation and Surveillance Department of the Safety Regulation Group for further guidance.

INTENTIONALLY LEFT BLANK

Leaflet C-100 Radio Apparatus for use in Aircraft for other than Flight Operational Purposes

PURPOSE: This Leaflet provides information and guidance concerning the approval and installation of Radio equipment for use in aircraft for other than Flight Operational Purposes.

The Leaflet is only applicable to non-EASA aircraft.

REFERENCES: Air Navigation: The Order and the Regulations, CAP 393.
British Civil Airworthiness Requirements (BCAR), Sections A, B and R.
EASA Certification Specifications: CS-23, CS-25, CS-27, CS-29 and CS-ETSO.
Office of Communications (Ofcom).
Radio Frequency Allocations, (see website: <http://www.radio.gov.uk/>).
CAAIP Leaflet 25-20, 'Use of Electrically Powered Medical Equipment on Aircraft'.
JAA Administrative and Guidance Material, Section One: General, Part Three, Temporary Guidance Leaflet: Leaflet No. 17: Passenger Service and In- Flight Entertainment (IFE) Systems.
JAA Administrative and Guidance Material, Section Four: Operations, Part Three, Temporary Guidance Leaflet (JAR-OPS) No. 29.

CANCELLATION: This Leaflet supersedes and cancels ALL/0167 dated 29 October 2004.

1 Introduction

The Air Navigation Order (ANO) requires all radio equipment carried on UK registered civil aircraft to be of a type approved by the CAA or EASA. This Leaflet provides guidance on the approval procedures to be followed to gain CAA approval of radio equipment that is to be used for purposes other than normal flight operations. Typically, such equipment includes radio transceivers for work involving surveillance, survey, marine communications, emergency services operations, passenger communications, and trials.

This Leaflet is updated to: clarify the approval criteria for equipment and installation, add reference to ETSO-2C514 and to clarify the circumstances where licensing matters are addressed by Ofcom rather than DAP.

2 Approval Categories

BCAR Section R and Volume 2 of CAP 208 (now obsolescent – CAP 562 General Information Section, Airworthiness Publications refers) lists approval categories which have the following designations:

Approval number prefixed by – WR, VC, LAI or LAIII.

Within BCARs other approval categories exist which have been applied to radio, they are:

Approval number prefixed by – Q, MISC, SA or G.

Non flight operational radios must be approved either in one of the latter categories or through the procedures described in section 4 of this Leaflet.

NOTE: EASA ETSO-2C514, Airborne Systems for Non-Required Telecommunication Services (In Non-Aeronautical Frequency Bands) (ASNRT), provides a minimum performance standard and a means to approve equivalent equipment for EASA aircraft.

3 Equipment Approval

3.1 Article 39(8) of the ANO 2009 (as amended) requires that all radio communication and radio navigation equipment installed in an aircraft registered in the UK, or carried on such an aircraft for use in connection with the aircraft shall be of a type approved by EASA or the CAA in relation to the purpose for which it is to be used.

NOTE: The 'type approval' required by Article 20(5)(a) may be achieved by the equipment approval process described in Section 3 of this Leaflet or as part of the approval of the modification (change) that installs it as described in Section 4 of this Leaflet.

3.2 Radio equipment are generally common user, non-aircraft specific items which can be CAA approved under a unique radio approval reference (see Section 2 of this Leaflet). BCAR Section A, Chapters A4-8 (Accessory Procedure) and A4-10, BCAR Section B, Chapters B4-8 and B4-10 refer.

3.3 The CAA may continue to approve these radios where it is determined that they are to be installed predominantly in non-EASA aircraft.

3.4 The equipment approval considers that the radio equipment should function as intended but no 'credit' is given for the performance capability of the system. Substantiation is required to demonstrate that the equipment and its installation does not affect the safety of persons, or the safe operation of the aircraft, and does not interfere with other radio users.

3.5 Organisations applying for CAA approval for such radio apparatus will need to provide adequate declarations and reports together with appropriate technical information regarding radio function to include:

- transmitter frequency range;
- spurious radiation;
- output power;
- frequency tolerance;
- modulation characteristics; and
- evidence of radio regulatory approval, e.g. Department of Trade and Industry (DTI), Federal Communication Commission (FCC).

Further data should be presented to determine that the radio will not constitute a hazard to the aircraft on installation, during operation or upon failure and may include considerations such as:

- the effects of temperature and altitude;
- mechanical integrity;

- magnetic effect;
- emission of RF energy;
- fire and smoke/fumes.

3.6 Application for the approval is made on CAA Form AD70 which is available from the CAA website on the 'Aircraft Equipment' page.

4 Equipment Approved as Part of Aircraft Design Change

4.1 The radio-transmitting devices that do not have a standalone aviation equipment approval may be approved as part of the modification (change) that installs it at the aircraft-level in accordance with BCAR Section A2, A4 (Component Procedure) and A8.

4.2 The data to support the aircraft-level design change should include the same technical data requirements identified in Section 3.5 of this Leaflet.

4.3 The installation design should ensure that adequate Electromagnetic Compatibility (EMC) tests are performed. These tests should be performed with the aircraft engines running, and with all required electrical and avionic equipment which can be operated on the ground in operation. The installed radio equipment should be operated over a range of frequencies throughout the operating band such as to establish that the level of radio and electrical interference is such as not to reduce the performance of any aircraft required system below a level compatible with the characteristic performance of the system. Systems that could be susceptible to interference include FADECs, engine computers, cockpit displays, required communication and navigation equipment and autopilot/flight director systems.

4.4 Where it is not practical to complete testing during ground tests (for example, on aircraft with engines controlled by FADEC), it may be necessary to perform a flight test.

4.5 Where safety is dependent on particular crew actions, a Flight Manual Supplement must be provided to present the limitations and procedures required for safe operation.

4.6 The electrical load analysis should show that the non-flight operational loads do not compromise the busbar loading, generator ratings and battery duration.

4.7 If the radio equipment being installed is commercial off-the-shelf (COTS) or is based on COTS equipment, then the design data supporting the aircraft-level change will include a 'specification' which in addition to the data requirements of Section 3.5 of this Leaflet, will typically:

- prescribe an inspection/test process to ensure that the commercially sourced equipment conforms to the expected design standard;
- take due account of any potentially unsafe operating or failure modes of the original COTS equipment and provide design change and/or test solutions to mitigate them;
- prescribe the appropriate part marking scheme (which will require a new part number if the COTS equipment is modified as a line replaceable unit).

For further details on the use of COTS equipment, refer to Leaflet B-110.

5 Licensing Considerations

- 5.1 The operation of radio-transmitting equipment is subject to the issue of a Wireless Telegraphy Act Aeronautical Radio Licence. The Radio Operators Licence required for the operation of the equipment shall not preclude airborne use and it is the responsibility of the aircraft owner/operator to complete the relevant application form.
- 5.2 The Directorate of Airspace Policy (DAP) of the CAA has been appointed by the Office of Communications (Ofcom) as its agent to distribute Wireless Telegraphy Act Aeronautical Radio Licences.
- 5.3 For transmitting equipment operating in aeronautical bands, application form DAP 1902 (ACT1 1001) should be completed and returned to the Radio Licensing Section of the Directorate of Airspace Policy at the address below:
- Radio Licensing Section
Directorate of Airspace Policy
K6 Gate 6
CAA House
45-49 Kingsway
London WC2B 6TE
- Tel. 0207 453 6555
Fax. 0207 453 6556
E-mail radio.licensing@caa.co.uk
- 5.4 For equipment operating in non-aeronautical bands, the licence is granted by Ofcom. It is not covered by the Wireless Telegraphy Act Aeronautical Radio Licence and no application to DAP is necessary.
- 5.5 The licence for radio equipment installed in aircraft for emergency services (e.g. police or ambulance) or taxi communications is typically covered by an extension to, or included within, the licence granted for the associated ground station. Similarly, licensing for other non-aeronautical radio equipment could be covered by an extension to the applicant's Radio Wireless Telegraphy Act Licence. All enquiries should be directed to Ofcom.

Leaflet C-110 A Simplified Means of Approval for Airframe Structural Repairs Design

PURPOSE: To provide information on the procedures acceptable to the CAA for approval for airframe structural repair design on aircraft operating under CAA Regulatory Approval (i.e. Annex II to EU Regulation (EC) No. 216/2008).

REFERENCES: BCAR Section A and B Chapter 5-3 paragraph 2.1
BCAR A and B Chapter 6-7 paragraph 2.1.1
CAP 562 Leaflet C-20, Appendix 2

1 Introduction

A revised and simplified means of repair design approval has been developed following a review of the procedures within the Airworthiness Division. The procedure places more reliance on repair approval granted by foreign regulatory authorities and does not necessitate a change to any requirement. For the purposes of this document, 'foreign' means non-UK.

2 Background

There are currently two chapters within BCAR A and B that define the CAA's requirements on repair design approval to aircraft.

- a) **BCAR Section A and B Chapter 5-3 paragraph 2.1** allows manuals containing information necessary for the repair of aircraft, such as the Structural Repair Manual (SRM), to be certified and published under the authority of the appropriate Approved UK Type Design Organisation (TDO) or in the case of foreign TDOs, under the local regulatory process. Repairs in the SRM, therefore, do not need to be approved directly by the CAA, nor do amendments to the SRM. There has been no change to this procedure.
- b) **BCAR Section A and B Chapter 6-7 paragraph 2.1.1** requires that repairs shall be carried out in accordance with 'the approved Manuals, drawings and schedules related thereto, **and any other documents required or recognised by the CAA.**' In this context 'approved' means certified by the UK TDO, or in the case of foreign TDOs, under the local regulatory process.

The change to the CAA's procedure is in the interpretation of the bold text above.

3 Revised Procedure

It is now the intention that, for repairs designed by the TDO, a document approved under the local regulatory process is considered by the CAA as '...documents.... recognised by the CAA.'

Repairs designed by foreign and domestic TDOs need to be considered separately:

- **Repairs of Foreign TDO origin.** Where the repair has been designed by the foreign TDO responsible for the type, documentation for the repair approved under the local regulatory process (e.g. on behalf of the FAA by the US TDO Designated

Engineering Representative (DER) using the FAA Form 8110-3) will be considered as a recognised document in accordance with BCAR B6-7, paragraph 2.1.1.

- **Other foreign repairs.** Where the repair has been designed by a foreign organisation that is not the TDO for the type and has been approved under the local regulatory process, it will need to be investigated by the CAA. However, appropriate credit will be given for the domestic certification in the CAA validation process. STC holders fall under this category.
- **Repairs of UK TDO origin.** As the CAA is the local regulatory authority, all repairs may be processed under the normal BCAR Section A procedures. However, as an alternative, if the UK TDO wishes to avoid the potential delay associated with seeking CAA approval of each repair, repairs may be associated with the SRM. Such associated repairs may be certified under the authority of the TDO (see BCAR A5-3 paragraph 2), providing the TDO's Terms of Approval permit the design of repairs and there are applicable procedures referenced in the Company's Exposition. Note that these associated repairs must be subject to the same airworthiness controls as the SRM.
- **Other UK repairs.** For UK Approved Design Organisations who are not TDO, and who are taking full design responsibility for the repair, the current procedures of BCAR A2-5 still apply.

4 General Points

Apart from the normal auditing of the UK TDO, the CAA reserves the right to directly investigate any repair from the TDO (UK or foreign) in exceptional circumstances. Examples of this might be:

- if survey of an aircraft raises questions about a repair's suitability;
- if the repair is novel or very extensive;
- if the repair is found to conflict with the applicable CAA requirements.

Repairs may be approved and aircraft released to service while awaiting any required damage tolerance evaluation. Up to a 12 month period for evaluation to be completed and for incorporation into the Aircraft Maintenance Schedule (AMS) is acceptable. There must be a procedure for any resulting inspections to be placed in the AMS. Under normal circumstances aircraft would not be released into service without the requisite approval documentation being in place. This would include documents such as 8110-3 or Repair Assessment Sheet (RAS), but not a 'No Technical Objection' (NTO).

A statement of 'No Technical Objection' from the TDO does not constitute approval of a repair, although this may be necessary supporting documentation for repair approval.

5 Repairs to Aircraft Operating under EASA Design Control

Reference should be made to CAP 562 Leaflet C-20, Appendix 2 - Acceptable Data for use by Part-145 Organisations.

Leaflet C-120 Restoration, Airworthiness Control and Maintenance of Aircraft of Ex-military Origin under a BCAR Chapter A8-20 Approval

PURPOSE: This information is issued for the guidance of applicants seeking an approval under BCAR A8-20 and CAA staff when they are investigating such an approval.

BCAR A8-20 contains the requirements for making submissions to the CAA for the grant of initial approval and the maintenance of ex-Military aircraft above 2730 kg. The other requirements of BCAR sections A and B remain applicable, in particular chapters A3-7/B3-7.

REFERENCES: BCAR Chapters A3-7, B3-7, A8-20, CAP 632.

1 Introduction

- 1.1 An organisation approved under BCAR A8-20 may according to the scope of its approval, make a submission to the CAA for initial approval of an ex-military aircraft, perform maintenance, repair, defect rectification, inspection and modification of an aircraft and its related components, including complete rebuild or restoration of the aircraft, and make a recommendation for the issue or renewal of a Permit to Fly.
- 1.2 This Leaflet should be read in conjunction with BCAR A8-20. This Leaflet is issued primarily to give guidance for those organisations that are applying for approval under BCAR A8-20. The guidance is provided in two separate appendices to this Leaflet. Appendix 1 corresponds with paragraph 1.2.1 of BCAR A8-20 (E4 approval) covering design related aspects of ex-military aircraft. Appendix 2 relates to those organisations requiring approval for recommending the renewal of a Permit to Fly under paragraph 1.2.2 of BCAR A8-20 (M5 approval).
- 1.3 The information provided in the Appendices of this document is intended to provide guidance on the interpretation of the requirements and procedures required of the organisation in order to obtain approval for ex-military aircraft.
- 1.4 The organisation must be defined in an exposition and this must contain adequate control procedures for review and approval of the aircraft in question. The types of aircraft to which the approval relates will be defined in the exposition of the organisation by means of capability lists. These lists will be subject to the agreement of the CAA and the exposition must contain adequate control procedures for review and approval of these lists.
- 1.5 Organisations holding an approval under paragraph 1.2.1 (E4) or paragraph 1.2.2 (M5), if applying for an extension for the other associated approval, will be required to meet the criteria of the other approval and amend the existing exposition.

INTENTIONALLY LEFT BLANK

Appendix 1

BCAR CHAPTER A8-20 EX-MILITARY AIRCRAFT

DESIGN ASPECTS - E4 APPROVAL

1 Introduction

- 1.1 This Appendix provides guidance on the organisational requirements and responsibilities for organisations requiring to hold an E4 approval in accordance with paragraph 1.2.1 of BCAR A8-20. This approval is required for organisations to recommend that the CAA make initial issue of a Permit to Fly for an ex-military aircraft.

2 Personnel

- 2.1 The organisation should nominate the key design and/or engineering staff who are to support its operation. These staff should be employed under a formal agreement between the organisation and the staff member concerned with details of their terms of reference as senior members of the organisation provided within the exposition.
- 2.2 The organisation should have a staff member - see A8-20 3.2(b) - who should be a senior engineer and who will be the nominated contact with the CAA Design Liaison Surveyor and who will gather, co-ordinate and submit evidence required to the CAA in order to establish the standard of particular aircraft (see A8-20 3.2(c)). This person should have adequate qualifications and experience appropriate to the category of aircraft concerned.
- 2.3 Additional part time staff may be used to supplement the company resources where necessary, providing that there are in existence suitable control procedures within the organisation exposition. A form of agreement should be raised which gives detailed terms of reference in writing to each such person. Such arrangements may be required in order that the organisation is able to draw upon sufficiently qualified and experienced personnel to cover specific design aspects such as the research needed to establish the design standard of particular aircraft (see A8-20 3.2(c)), or structural substantiation (or check stress signatory) of a repair or material substitution.
- 2.4 CAA Forms AD458 declaring relevant qualifications and experience for persons nominated under the A8-20 approval should be submitted to the CAA Airworthiness Division, Organisations Section at Gatwick.
- 2.5 The Exposition will include charts showing chains of responsibility and signatories for documents to be submitted to the CAA.
- 2.6 The Exposition of organisations approved to cover *Complex* aircraft will include copies of the formal agreements with each external organisation providing support of the *Complex* aircraft and its systems and equipment.

3 Procedures

- 3.1 Two ex-military aircraft ostensibly of identical type may be of significantly differing design/build standards and fatigue states and for this reason the CAA does not consider that it is generally possible to accept one aircraft as series to another. Because of this each aircraft requires an individual investigation culminating in issue

of an Airworthiness Approval Note specific to it, for approval and initial issue of a Permit to Fly. However, cross referencing to previous AANs for the same type is acceptable in areas where the design/build standard is identical.

- 3.2 The basis upon which ex-military aircraft may qualify for issue of a Permit is referred in BCAR A3-7/B3-7 paragraph 3.1(d) and the Appendix 1 to BCAR A3-7/B3-7 lists the evidence required to substantiate applications for Permits on this basis. The A8-20 E4 organisation responsible for gathering the evidence necessary for substantiation of submissions to the CAA is responsible for maintaining documentary records covering these submissions. Particular aspects covered by the organisations procedures covering the following may need to be covered in the exposition:

3.2.1 **Initial Application to CAA and Establishment of Aircraft Complexity Grouping.**

The organisation should make initial application to the CAA for approval of the aircraft early in the process (Form CA3). The applicant should also propose and obtain CAA agreement of the grouping (see paragraph 1.2.1 of BCAR A8-20) of the particular aircraft early in the process. The proposal should contain sufficient information on the design features of the type to justify the recommendation.

3.2.2 **Establishment of Safety Record (BCAR A3-7/B3-7 Appendix 1 paragraph 2.1)**

Investigation of *Intermediate* and *Complex* aircraft of a specific type which the CAA have not yet accepted will commence with a demonstration that the aircraft type has a safety record in service acceptable to the CAA for its intended use. Combat losses or those directly attributable to peculiarly military operational causes such as low level training may be discounted but a review employing such judgements should be made by appropriately qualified personnel. The organisations procedures should include presentation of the safety record (total loss and fatal accidents per million flying hours) to the CAA for acceptance prior to commencement of the main investigation of design and build standard. Such presentations to be made by the nominated personnel accepted by the CAA for the purpose.

NOTE: It may be possible to establish that particular aircraft were hazardous in specific operational circumstances, or that particular modifications rendered the aircraft hazardous. In this event, it may be that application of particular limitations may render the aircraft type acceptable to the CAA. In the case of complex aircraft, in most cases, the CAA will require that such submissions are supported by the manufacturer.

3.2.3 **Continued Airworthiness Support/Information**

The more complex the aircraft, the more necessary it will be to have adequate technical/design expertise of the type in order to maintain the level of continued airworthiness support. For organisations supporting only Simple or Intermediate types, it may not be possible to retain permanent staff of adequate capability to cover initial approval of a given aircraft. In these cases adequate arrangements should exist to cover initial approval and continued support of each aircraft.

Complex aircraft will require permanent support covering each aspect, and may require additional specialist support covering aspects such as powered flying control systems, variable geometry intakes and nozzles, reaction control systems, digital (computer) controlled systems. Some types may only be considered supportable by the armed forces who operated them or by the manufacturer. The Exposition of organisations approved to cover *Complex* aircraft should include procedures for the necessary interface with the manufacturers providing support for the aircraft and of its critical equipment, and/or an acceptable Military Authority. The nature and depth of such procedures will be subject to the agreement of the CAA.

In all cases where the type continues to be actively supported by the manufacturer (i.e. examples of the type are still in operational service), arrangement should be made with the manufacturer to provide copies of all continued airworthiness information (i.e. SBs, STIs etc.) to the organisation.

3.2.4 **Establishment of Conformity to Type Design Standard** (BCAR A3-7/B3-7 Appendix 1 paragraph 2.2)

The organisation will have a procedure to establish that the individual aircraft conforms to the type Design Standard to which the established safety record is related. This involves ensuring that any modifications necessary to maintain the standard of airworthiness are determined and incorporated. This includes obtaining lists (in the English language) of Manufacturers (and/or the Military Engineering Authority's, Military Operators) modifications which were considered essential for airworthiness, and reviewing the aircraft and its accompanying paperwork to ascertain that each such modification is embodied. The Exposition will show that the signatory in respect of BCAR A8-20 3.2(c) will compile a statement against each such modification showing embodiment or acceptable alternative.

This may also include RAF Special Technical Instructions (STIs), Service Instructions (SIs) etc. Compliance with Mandatory Permit Directives promulgated by CAA for the type is also required.

The following aspects will be covered as part of establishing conformity to Design Standard:

a) **Fatigue State**

The organisation will:

- i) research and identify fatigue critical components, their lives and accounting procedures;
- ii) check that all such components are identifiable within these limits and this is supported by documentary evidence covering the full life of the aircraft;
- iii) obtain CAA agreement for procedures as applied to civil operation of the aircraft (role factors etc.)

NOTE: Statements for submission to the CAA should be signed by nominated personnel (BCAR A8-20 paragraph 3.2(c)).

b) **Identification of Limitations**

The organisation will identify and record normal operating limitations appropriate to the aircraft and to observe any limitations that the CAA may determine having regard to the safety of third parties and occupants during intended operations of the aircraft.

NOTE: Limitations should normally be supported by copies of published documentation. Examples of circumstances where more restrictive limitations may be applied (subject to agreement of the CAA) are:

- i) where flight test has identified an unsafe part of the envelope to be avoided;
- ii) where the equipment fit renders more restrictive limits appropriate, for instance restriction of maximum altitude as a consequence of lack of oxygen system;
- iii) where the operator chooses to operate an engine within published limitations in order to conserve engine condition.

NOTE: Specialist Equipment such as Ejector Seats and Drop Tanks should be subject to particular investigation.

c) **Published Information**

The organisation will obtain copies (English language) of all documentation necessary in order to operate and maintain the aircraft. This will normally include Aircrew Manual or Pilots Notes, and schedules and manuals covering airframe, engine and propeller overhaul, maintenance and repair. Any specialist systems should be covered adequately.

3.2.5 **Modifications made by the A8-20 E4 Organisation**

In general the normal CAA procedure as detailed in BCAR A2-5/B2-5 will apply. The E4 approval granted under BCAR A8-20 approval does not confer approval of any activity to design or seek approval for Major Modifications on this class of aircraft. Minor modifications to aircraft or components are required to be submitted either to the local CAA Regional Office, along with technical justification, to substantiate such change or alternatively be submitted via a suitably CAA approved design organisation.

Significant changes to the aircraft in terms of powerplant changes, propeller type, alternative material specifications or equipment changes (to ensure that the aircraft is equipped to a standard acceptable to the CAA for the intended purpose) may be the subject of major modification action, but all such applications should be discussed with the CAA. If the E4 approved company wishes to undertake such work they should make application for CAA Approval under A8-8(E1) and/or A8-2(A2), but approval may require additional personnel with specialist qualifications and experience.

While the aircraft should conform as closely as possible to the Type Design Standard in respect of which the safety record has been accepted, it is recognised that the operating organisation may wish to embody modifications in order to simplify operation of the aircraft (such as replacement of non-standard oxygen supply connectors with NATO standard connectors). The A8-20 E4 organisation's Exposition will include a procedure whereby such modifications are identified, defined, and submitted to the CAA for approval (these may form part of a submission for initial approval of an aircraft). Such modifications are to be adequately defined on modification sheets to include drawings, circuit diagrams and changes to Pilots Notes showing effect on limitations and operation, and justification.

- NOTE:**
- 1 In the event that the initial basis of acceptance of an aircraft into service is not known in detail, the justification for approval of such a modification is subject to agreement of the CAA (e.g. compliance with appropriate parts of a design code such as BCAR Section K, JAR-23 etc.).
 - 2 Material substitution during manufacture of replacement parts (in accordance with paragraph 8 of Appendix 2 to this Leaflet) or any repairs not identifiably made in accordance with manufacturers repair manuals constitute modifications which must be properly approved.

Major Modifications to *Complex* aircraft should be accepted in writing by the manufacturer supporting the aircraft prior to CAA approval.

3.2.6 **Compilation of Draft Airworthiness Approval Note (AAN)**

The organisation will have a procedure to submit a draft AAN for CAA acceptance in order to summarise the results of investigations as above prior to issue of the Permit to Test. Although the AAN will continue to be produced and signed by the CAA, in order to minimise administration involved, the applicant (E4 organisation) is expected to provide a draft which will summarise all the aspects covered above and culminate

in a recommendation (signed by nominated signatory) that the CAA issue the Permit to Fly.

The applicant's procedures should provide for submission of the draft AAN to the CAA and arrangement of the CAA survey of the aircraft to occur prior to flight test.

- NOTE:**
- 1 The CAA will on request provide examples of AANs.
 - 2 Maintenance schedules, where they differ from published schedules are subject to the agreement of the CAA Regional Office. A maintenance schedule should be agreed prior to issue of a Permit to Fly.

3.2.7 Flight Test Arrangements

The organisation will have a procedure covering conduct of the necessary flight testing of the aircraft as required by the CAA. The test schedule and the pilot should be accepted by the CAA and a draft AAN (see 3.2.6 above) accepted by the CAA prior to test.

4 Exposition

- 4.1 The Exposition should be kept as simple as possible, appropriate to the size of the organisation to be approved. Full quality functions are not required but may be accepted if already in place.
- 4.2 The Exposition should contain a capability list. This list may include blanket coverage for aircraft in the Simple or Intermediate categories (see paragraph 1.2.1 of BCAR A8-20), but will be on a type-by-type basis for Complex aircraft.
- 4.3 The Exposition should have a BCAR approval certified statement signed by the accountable manager as follows:

This Exposition defines the Organisation and Procedures upon which Civil Aviation Authority Approval AI/...../.... is based. These procedures are approved by the undersigned and must be adhered to as applicable when the Organisation is performing the functions relating to which the approval is granted.

It is accepted that the Organisation's procedures do not over-ride the necessity for compliance with the Air Navigation Order, British Civil Airworthiness Requirements or other requirements published by the Civil Aviation Authority from time to time.

The Company will ensure, prior to undertaking any overhaul, repair, modification, test or inspection, that all Manuals, Service Bulletins, Modification Standards, Mandatory Documentation, Special Tools (including test equipment) and any necessary training required by the Manufacturer or Civil Aviation Authority are obtained.

HEAPWARBIRD LTD

signed

Accountable Manager.

INTENTIONALLY LEFT BLANK

Appendix 2

BCAR CHAPTER A8-20 EX-MILITARY AIRCRAFT

MAINTENANCE ASPECTS - M5 APPROVAL

1 Introduction

This Appendix provides guidance on the organisational requirements and responsibilities for organisations requiring to hold a Group M5 approval in accordance with paragraph 1.2.2 of BCAR A8-20. This approval is required for organisations to maintain and recommend that the Authority renew a Permit to Fly for an ex-military aircraft.

2 Personnel and Staff

- 2.1 The organisation should nominate the key engineering staff who are to support its operation. These staff should be employed under a formal agreement between the organisation and the staff member concerned with details of their terms of reference as senior members of the organisation provided within the exposition.
- 2.2 The organisation should have a minimum of one staff member who is nominated as a senior engineer who holds CAA licences without type ratings appropriate to the aircraft to be maintained. Where this cannot be satisfied in the case of established organisations, well known to the Regional Office, an unlicensed person with long association with the CAA may be acceptable.
- 2.3 Additional part time staff may be used to provide additional resources providing there are in existence suitable control procedures within the organisation exposition. A form of agreement should be raised which gives detailed terms of reference in writing to the volunteer.
- 2.4 CAA Forms AD458 Biographical Details for persons nominated under the A8-20 approval should be submitted to the regional office.

3 Organisation Personnel Authorisations

- 3.1 A nominated senior person as required under BCAR A8-20 paragraph 3.2(b) will be accepted by the CAA to grant personnel authorisations under the organisation's approval, appropriate to the staff who are to carry out nominated functions and activities whilst contracted to or in the employ of the organisation.
- 3.2 A limited number of full authorisations may be granted, on a restricted basis, for issuing a flight release certificate after scheduled maintenance or defect rectification. In respect of aircraft nominated under A8-20 paragraph 1.2.1 as *Complex*, the signatory of the Flight Release Certificate (see BCAR A3-7 appendix 2) would be a suitably qualified person with appropriate practical experience, gained whilst employed by either the manufacturer or an acceptable Military Authority.
- 3.3 Authorisations may be granted for specific functions as are seen to be necessary to support operations either at the main base or away from that base. e.g. taxiing, ground runs, pre-flight checks etc.
- 3.4 Records of authorisations given shall be kept and issued to the persons involved.

4 Inspection and Certification

The organisation should ensure that all maintenance and defect rectification is recorded and certified by the appropriate staff with details of the necessary action taken. The procedure should be in a form acceptable to the CAA and take due account of any flight record system required by CAP 632 for the operation that is supported.

It is expected that the normal aviation practices for the documenting of maintenance checks and recording defects with subsequent rectification will satisfy this requirement.

Maintenance check sheets should provide information of the amendment status of the maintenance programme when work is certified. A work records control system should be established to show the status of completion of work at any time and be readily capable of review.

5 Maintenance Programmes

- 5.1 The compilation of maintenance programmes and the associated schedules should where possible be based upon the original aircraft type documentation and should reflect both the original servicing elements and any additional requirements of the CAA. This should take into account any known service experience such as NDI programmes and supplementary inspections and be adjusted to suit the aircraft utilisation rate. The need to change the periods from flying hours or cycles to calendar based periods should be considered and agreed by the CAA. Part of the maintenance schedule should contain life limitation listings and reflect any component overhaul or life limitations, fatigue limits or other significant data.
- 5.2 In some instances major structural inspections are not included in the military service notes, this should be taken into account when compiling the programme of maintenance. Where possible the original manufacturer should be consulted if doubt exists regarding the adequacy of the structural programme, or the CAA Airworthiness Evaluation and Surveillance Department.
- 5.3 The maintenance schedules for the aircraft should also take into consideration the general requirements of the LAMS schedule; e.g. compass swings, radio checks etc.

6 Spares Procurement

- 6.1 All the required spare parts and components procured for this type of aircraft should, wherever possible, be obtained from original sources or through known and reputable distributors.
- 6.2 Where items are obtained via Military, or other related sources these items should be inspected and evaluated with regard to physical condition, life details, completeness of records, modification status and compatibility to aircraft serial by the organisation purchasing the item. Acceptance of the item following such inspection should be assessed and recorded by a certifying engineer prior to fitment. This procedure should be reflected in the associated exposition.
- 6.3 During the conditional assessment of components consideration must also be given to the need to carry out an internal examination to assess the effects of age and corrosion. It may be necessary to carry out a strip investigation, partial or full, if the component's condition cannot be readily assessed by other means, e.g. boroscope, NDT, etc.

- 6.4 Structural components, forging and castings should be visually inspected for condition and damage and consideration given to utilising NDT techniques to assist such an inspection, whenever possible the manufacturers advice should be sought.
- 6.5 Engines, propellers and gearboxes should be overhauled prior to their initial fitment to the aircraft except where the item's service history and current status is known and documented. The overhaul should be carried out by an organisation approved for the purpose or by a company as agreed within the terms of the A8-20 organisation's exposition.
- 6.6 AGS and Standard Parts. Standard aircraft hardware such as fasteners, e.g. nuts and bolts, should be purchased from normal aviation sources. These should conform to the specified part number in the manufacturer's maintenance information. Where this information differs from the current specifications for those items in civil use, acceptance via a certificate of conformity showing equivalence will suffice.
- 6.7 Where items are no longer manufactured or available from known sources, caution should be exercised on the acceptance of items unless their serviceability can readily be determined by inspection and/or overhaul. The use of alternative parts in the overhaul or maintenance of aircraft or components is only permitted when supported by the agreement of the manufacturer or an approved Design Organisation, through modification action, or where agreed in individual circumstances with the CAA Regional Office.

7 Arrangements for Maintenance of Specialised Equipment

- 7.1 The arrangements for the maintenance and overhaul of items and systems as detailed in paragraphs 3.2. and 3.4 of A8-20 Supplement No. 1 should be defined in the organisation's exposition. Where the organisation does not hold the capability itself to satisfy this requirement, suitable letters of agreement with appropriately approved organisations should be held detailing the provisions made to cover all such undertakings.

8 Component Manufacture

- 8.1 With regard to the manufacture of components, the A8-20 approval is not intended to replace the requirements of a BCAR A8-2 Group A2 Supplier Approval. Manufacture of non critical parts may be permitted subject to the organisation having the necessary drawings and facilities, equipment, etc. where the part is intended to be produced only for an aircraft supported by the approved organisation.
- 8.2 Major structural items should be manufactured under the control of a BCAR A8-2 company to the required specifications and original drawings, unless agreed otherwise in advance by the local CAA Regional Office. Any deviation in material specification, heat treatment or manufacturing process will need to be supported by technical justification and a prepared case should be submitted in the form of individual requests to the CAA Regional Office.
- 8.3 Manufacture to pattern is normally prohibited, however specific items may be agreed by the CAA Regional Office in conjunction with Airworthiness Evaluation and Surveillance Department.

9 Modifications

- 9.1 The normal CAA procedure as detailed in BCAR A2-5/B2-5 will apply. The E4 approval granted under BCAR A8-20 does not confer approval of any activity to design or approve modifications on this class of aircraft. Minor modifications to aircraft or components are required to be submitted either to the local CAA Regional Office, along with technical justification, to substantiate such a change or alternatively be submitted via a suitably CAA approved design organisation.
- 9.2 Significant changes to the aircraft in terms of powerplant changes, propeller type, alternative material specifications or equipment changes may be the subject of major modification action, but all such applications should be discussed with the CAA Regional Office concerned in the first instance.

10 Secondary Site Control

- 10.1 Where the organisation intends to conduct activities at sites other than the main site of the approval but remaining under the control of the basic approved organisation, the additional geographical locations will be considered as secondary sites for approval purposes. The secondary sites should be environmentally suitable for the needs of the operations to be carried out and defined in the exposition. Short term agreements for secondary sites may be arranged by letter with the local CAA Regional Office and may be subject to any special conditions that are deemed necessary.
- 10.2 The term secondary site is not intended to include activities associated with line support of the aircraft during normal operations. Repairs or scheduled maintenance away from base may require to be reflected in a short term agreement as above.

11 Recommendations for the Renewal or Validation of Permits to Fly

- 11.1 The Permit to Fly will be a non-expiring document that requires an associated Certificate of Validity. These documents will be contained in a wallet.
- 11.2 The validation will be predicated upon an inspection report prepared by an organisation approved for the purpose (A8-20), and a recommendation made on Form AD202P.
- 11.3 Following an annual inspection, the approved organisation will submit the following documentation to the CAA:
- a) AD200 application for renewal;
 - b) Statutory fee;
 - c) Flight Test (if applicable - see 11.8);
 - d) AD202P recommendation.
- 11.4 The documentation listed in 11.3 should be sent to the CAA at the following address:
- Applications and Approvals Department
Civil Aviation Authority
Safety Regulation Group
Aviation House
West Sussex RH6 OYR
- 11.5 Subject to the submitted documentation being acceptable, a Certificate of Validity will be returned, valid for a twelve month period. The Certificate should be placed in the 'pocket' of the Permit to Fly wallet.

- 11.6 The validation process may be anticipated by a maximum period of thirty one days without loss of the twelve month consecutive validity period. If the anticipation period is more than thirty one days the Certificate of Validity will be limited to one year and thirty one days following the recommendation date. If the validity certificate has expired, the validity certificate will be dated from the date of receipt by the CAA and expire one year from the recommendation date.
- 11.7 If the Certificate of Validity has expired and a flight test is required, it will first be necessary to submit the AD200 application together with the statutory fee in order that the CAA may issue a Permit to Fly for test purposes. Following completion of the test, the flight test report and the AD202P should be submitted as in 11.3.
- 11.8 The Flight Test period has been extended to three years but must be completed for the first issue of the non-expiring Permit to Fly. The next flight test due date will be stated on the Certificate of Validity.

NOTE: AD202P pads will be supplied by the CAA.

12 Exposition

- 12.1 The Exposition should be kept as simple as possible appropriate to the size of the organisation to be approved. Full quality functions are not required but may be accepted if already in place.
- 12.2 The exposition should state the level of basic approval granted in the terms of one or more of the following:
- Maintenance of airframes and engines;
 - Overhaul of engines;
 - Restoration of airframes and associated systems;
 - Component Overhaul.
- 12.3 The Exposition should contain a capability list. This list may include blanket coverage for one or more Groups (see paragraph 1.2.2 of BCAR A8-20) but will specify individual aircraft types for those classified as Complex in accordance with paragraph 1.2.1(c) of BCAR A8-20.
- 12.4 The Exposition should have a BCAR approval certified statement signed by the accountable manager as follows:

This Exposition defines the Organisation and Procedures upon which Civil Aviation Authority Approval AI/ —/— is based.

These procedures are approved by the undersigned and must be adhered to as applicable when orders qualifying for release under the Approval are being progressed.

It is accepted that the Organisation's procedures do not over-ride the necessity for compliance with the Air Navigation Order, British Civil Airworthiness Requirements or other requirements published by the Civil Aviation Authority from time to time.

The Company will ensure, prior to undertaking any overhaul, repair, modification, test or inspection, that all Manuals, Service Bulletins, Modification Standards, Mandatory Documentation, Special Tools (including test equipment) and any necessary training required by the Manufacturer or Civil Aviation Authority are obtained.

HEAPWARBIRD LTD
signed
Accountable Manager.

INTENTIONALLY LEFT BLANK

Leaflet C-130 Sailplane Repairs in accordance with Regulation (EC) No. 216/2008

1 Purpose and Scope

- 1.1 This is the procedure for sailplane owners, maintenance organisations and continuing airworthiness management organisations, to ensure that damaged sailplanes, when subsequently repaired, continue to meet the requirements of Regulation (EC) No. 1702/2003, Annex Part 21. With effect from 28 September 2008, they shall also comply with Regulation (EC) No. 2042/2003 Annex I (Part M), with respect to continuing airworthiness.

2 Procedure

- 2.1 For a sailplane to continue to qualify for an EASA Certificate of Airworthiness it must continue to meet the requirements of EASA Part 21 (Annex to Regulation (EC) No. 1702/2003), in particular to the requirements for repairs and modifications to the airframe and its component parts.
- 2.2 In circumstances where a sailplane is damaged, e.g. a break to a major load bearing structure or component, i.e. fuselage, wing or tailplane, all repairs must be carried out by a suitably approved repair organisation under Part 145 or Part M subpart F and be supported by the sailplane Type Certificate Holder, or a suitably approved design organisation as required by Part 21 Subpart M.
- 2.3 Where a repair constitutes repair by replacement of the sailplane fuselage, the original sailplane and its associated records will retain the manufacturer's original serial number.
- 2.4 The manufacturer's original data plate will be transferred to the replacement fuselage. The aircraft serial number does not stay with the damaged fuselage. If the repair is carried out under an approved repair scheme/modification, the transfer of the data plate must be detailed and recorded within the repair scheme. If the repair is carried out under already existing design data, the transfer must be recorded in the maintenance records.
- 2.5 In the event that the damaged fuselage or major component is deemed to be repairable, the repair design must be approved in accordance with EASA Part 21 Subpart M.
- 2.6 A repaired fuselage (or major component) may be released back into service for use on another sailplane, i.e. treated as a replacement component, provided it has been repaired to an approved repair scheme, by a suitably approved Part 145 or Part M Subpart F repair organisation, with the capability to release the repaired component to service on an EASA Form 1. The authorised release certificate (EASA Form 1) shall include details of the approved repair scheme, and then as a minimum, the following:
- The current hours and cycles;
 - The date the last maintenance was carried out and by whom;
 - A list of all applicable airworthiness directives, repairs and modifications;
 - Details of the life used for service life limited parts (being any combination of either fatigue, overhaul or ultimate life limit);

- e) For any sailplane component having its own maintenance history record, where applicable, this should be attached to the EASA Form 1.
- 2.7 In summary, an organisation utilising a repaired major component (e.g. fuselage) in the repair of another sailplane, will have to demonstrate the following:
- a) Approved repair and build data (Part 21 Subpart M); and
 - b) Release documents for all component parts; and
 - c) Full history of all component parts as listed above.
- 2.8 When using a repaired component in the repair of another sailplane, the replacement part must be of the same type (as defined by the Type Certificate and by part number) and modification status as the component being replaced.
- 2.9 The component life used and, where applicable, ultimate fatigue life of a replacement part, should be recorded in the aircraft records and taken into account in relation to the future life of the sailplane. The aircraft records shall be updated to include the repair documentation and component replacement details. Associated documents (EASA Form 1) should be added to the records.
- 2.10 In all cases where a sailplane has suffered major damage, reference should be made to CAP 562 Leaflet C-140 'The Rebuilding and Restoration of Aircraft', and in particular, the need to inform the local CAA Regional Office at the earliest opportunity prior to commencement of work, and that a request for a special survey may have to be made.

Leaflet C-140 The Rebuilding and Restoration of Aircraft

1 Introduction

The CAA has been made aware that additional guidance is necessary for those engaged in the rebuilding or long term restoration of aircraft, to alert them to the airworthiness requirements and the monitoring of such projects by the Civil Aviation Authority Regional Offices.

2 Applicability

This Leaflet is applicable to aircraft that have previously held a UK/EASA Certificate of Airworthiness or Permit to Fly.

3 Definition

- 3.1 Restoration is a generic term that may include any one or combination of overhaul, repair, inspection, modification or replacement activity, which is to be performed on an aircraft where the UK Certificate of Airworthiness or Permit to Fly has lapsed for some years. Such an aircraft is likely to require extensive dismantling and inspection to determine the extent of work needed to restore it to an airworthy standard.
- 3.2 Aircraft rebuild projects include the return to an airworthy condition of any aircraft where the UK Certificate of Airworthiness or Permit to Fly has ceased to be in force due, for example, to accident or incident damage, the use of major parts from other aircraft of the same type, significant corrosion or major overhaul.

4 Background

- 4.1 From time to time the CAA is not made aware of major restoration or rebuild projects until they have reached the final stages of completion. This means that the necessary CAA stage inspections or surveys have not been carried out.
- 4.2 In many restoration cases the necessary repairs, including the production of parts no longer available from the original manufacturer, have not used approved data such as the original manufacturer's repair manual or design drawings, and have been outside the scope of the certification privileges of the Licensed Engineer. A number of rebuild projects have used structural components and major assemblies where the provenance and traceability of the parts fitted has been questionable.
- 4.3 For aircraft which held Certificates of Airworthiness, all replacement parts must either conform to the part number specified by the manufacturer for the particular aircraft type, model and serial number, or be approved under modification procedures in accordance with BCARs or EASA Regulations, as applicable. All replacement parts from whatever source must be serviceable and accompanied by appropriate documentation.
- 4.4 In the cases described in paragraphs 1 and 2 there have been delays in the CAA approval of the project and subsequent issue of the Certificate of Airworthiness or Permit to Fly and in some cases dismantling has been required to enable inspections to take place which could have been avoided by regular contact between the Licensed Engineer (or owners) and CAA Regional Offices.

5 Requirements

- 5.1 The attention of Certifying Engineers concerned with major rebuilding projects or the long term restoration of aircraft is directed to the relevant chapters of BCAR Section A/B, EU Regulations 1702/2002 and 2042/2003, as applicable. Reference should be made to the table below to assure compliance with the relevant regulations.

Requirement	Non EASA Aircraft	EASA Aircraft
It must be shown that the aircraft conforms to type design and any repairs and changes conform to appropriate data.	BCAR A/B3-2 Paragraph 1.3	Part 21.A.181 and 21.A.183
The aircraft must be constructed under the supervision of an organisation approved by the CAA for the purpose. The restorer or rebuilder must show proof that the major components proposed for use on the restored or rebuilt aircraft are original, i.e. were manufactured by or for the organisation who obtained the first Certificate of Airworthiness or Type Certificate for the aircraft or that they are an approved alternative. Failure to provide sufficient proof will result in the aircraft being refused either a Certificate of Airworthiness or a Permit to Fly.	BCAR A3-2 Paragraph 4	Part 145.A.42 and M.A.501
A Certificate of Release to Service shall only be issued for overhaul, repair, replacement, modification or inspection when the signatory is satisfied that the work has been properly carried out having due regard to the use of manuals, drawings, specifications and the use of calibrated tooling.	BCAR A/B6-2 Paragraph 8 and ANO 2009 (as amended) Article 28 or 32 as applicable	ANO 2009 (as amended) Article 28, 32, Part 145.A.50 or M.A.801, as applicable
In the case of structural repairs to aircraft, where the repairs are of a major nature or not covered in a particular Repair Manual, the Approved Organisation or the appropriately licensed maintenance engineer concerned, must be able to demonstrate all repairs are appropriately approved.	BCAR A/B6-7 Paragraph 2	Part 21 Sub Part M
All modifications/ changes, except those which are agreed by the CAA to be of such a nature that airworthiness is not affected, shall be approved.	BCAR A/B2-5 Paragraph 2.1.4	Part 21 Sub Part D

Aircraft with Permits to Fly

All of the above references apply to aircraft with Certificates of Airworthiness. For aircraft holding Permits to Fly, the CAA needs to be satisfied that similar standards have been achieved, including, as far as possible, reference to original drawings and data. This should include compliance with the Airworthiness Approval Note for the particular aircraft being restored (these aircraft are not accepted by the CAA as series aircraft).

6 Procedures

- 6.1 In the case of a rebuilding or restoration project expected to exceed fifteen months duration, the local CAA Regional Office (see CAAIP General Information, Contact Details for UK Regional Office addresses) must be advised of the project at the

earliest opportunity. This will allow for a preliminary assessment by a Regional Office Surveyor of the extent of the restoration work required and initial acceptance of the applicant's proposals regarding sourcing of parts and components to be used in the restoration.

- 6.2 Normally, if the Regional Office Surveyor decides that the restoration or rebuilding project is of such a magnitude that regular inspections will be necessary, a Special Survey will be needed. Alternatively, it may be necessary, by virtue of the extent of the rebuild or restoration required, that a major modification will be needed instead of a Special Survey to record and approve the proposed repairs or replacements. If this is the case the Regional Office Surveyor will advise the potential applicant accordingly.
- 6.3 An application for a Special Survey should be made by the owner to Applications and Approvals Department at Aviation House, Gatwick (see CAAIP General Information, Contact Details).
- 6.4 Following acceptance by CAA of an application for a Special Survey it will not be necessary to make an application for the subsequent issue of a Certificate of Airworthiness or the renewal of the Permit to Fly, as the case may be, until the final stages of completion unless a modification / change which has not previously been approved is to be embodied on the aircraft. In some cases it may be that following a Special Survey no recommendation can be made by the Regional Office Surveyor for the renewal of the Certificate of Airworthiness or Permit to Fly. In these cases the applicant will be advised of the reasons why the aircraft could not attain certification and any Certificate of Airworthiness or Permit to Fly fee already paid will be refunded. The cost of the Special Survey will, however, still have to be met by the applicant.

INTENTIONALLY LEFT BLANK

Leaflet C-150 Applications for the Approval of CAA Supplemental Type Certificates

PURPOSE: To advise applicants of the information they will have to provide in support of an application for the approval by the CAA of a Supplemental Type Certificate (non-EASA) for an aircraft, engine or propeller as defined by Annex II.

REFERENCES: Regulation (EC) No 216/2008 of 20 February 2008 including amendments, on Common Rules in the field of Civil Aviation and establishing a European Aviation Safety Agency.
Regulation (EC) No 1702/2003 of 24 September 2003, including amendments, Implementing Rules for Airworthiness and Environmental Certification of Aircraft and Related Products, Parts and Appliances, as well as for the Certification of Design and Production Organisations.
EASA Website: www.easa.europa.eu
CAA Scheme of Charges, Official Record Series 5
Part 21.101; Changed Product Rule

1 Introduction

This Leaflet is for Annex II aircraft only and does not apply to any product under the authority of EASA as defined by Regulation 216/2008. Mutual recognition is not automatically achieved within EASA Member states for STCs to Annex II products.

This Leaflet is to inform owners, operators, designers and modifiers of aircraft of the CAA procedures for the approval of Supplemental Type Certificates (STC). The Leaflet has particular emphasis on the information which the applicant will be expected to provide to the CAA. The procedure to be followed is similar to that required by EASA under Regulation 1702/2003 however it must be noted that EASA has developed their own procedure for STC applications that can be found on the EASA website.

The EASA STC Procedures classify STCs from a procedural point of view into Significant and Non-Significant. A Significant 1 STC is defined as "a major design change, which necessitates a change to the Type Certification basis referenced in the TCDS for the Product". A Non-Significant STC is any other STC.

It is important to note that these STC Procedures are an alternative and not a replacement for the Airworthiness Approval Note (AAN) Procedures.

2 Application

Application for issue of an STC to an Annex II Product may be made to the CAA by:

- a) A UK applicant;
- b) A non-UK applicant for an STC to be validated.

NOTE: This is conditional on the applicant being subject to the jurisdiction of an Authority, which has entered into, or is prepared to enter into an Arrangement with the UK.

Application must be made on the relevant CAA Form No STC01 (Appendix 1), to Applications and Approvals Department together with the appropriate fee.

3 Classification

At time of application, the applicant must propose the category of the STC with appropriate justification. This justification will be reviewed in accordance with the criteria defined in Part 21.101 at the discretion of the CAA.

4 Registration

When the application has been accepted, the Project will be issued with a CAA STC Project Number taken from the CAA STC Project Number register. The register for aircraft and engines/propellers is maintained by Applications and Approvals Department.

The STC Project Number will be used as the CAA charging number as well as the reference for the department file and all correspondence during the Project.

The STC Project Number will be in the form PNxxxxx and will not be the same as the STC Number.

5 Design Investigation

5.1 CAA Team

The CAA will identify a team having regard to the Product, the applicant, the complexity of the Project, and the anticipated length of the Project. The Team Leader will normally be from either Airworthiness Evaluation and Surveillance Department or Engineering Department and will be responsible for the management of the STC Project.

The Team Leader will advise the applicant of the Team membership, which may comprise representatives from within the Airworthiness Division (including Airworthiness Evaluation and Surveillance Department) and Flight Operations Division.

5.2 Design Organisation Approval

The Applicant will be required to hold a Design Organisation Approval recognised by the CAA. The Team Leader will be responsible for ensuring that the terms of the applicant's Approval, as applicable are observed during the certification exercise. The Team will determine if the Terms of Approval are sufficient to cover the scope of the STC. If necessary the Applicant may be required to apply to the CAA to update the Terms of Approval in order to include the new STC.

5.3 Information Exchange

When the CAA is validating an STC from a non-UK applicant the Team Leader is responsible for ensuring appropriate information exchange links with the Authority of the State of Design.

The applicant will advise the Team Leader of any arrangement with the Type Certificate Holder. This information is requested on the Application Form.

5.4 Certification Basis

For a Non-Significant STC the Certification Basis is that referenced in the applicable CAA Type Certificate Data Sheet for the Product.

For a Significant STC the Certification Basis will be agreed between the Team and the Applicant.

5.5 **Demonstration of Compliance**

STC Definition Document

The applicant should provide a STC Definition Document (or equivalent documentation) to the Team. This document provides a summary of the change, including a description of the change and reference to supporting drawings, diagrams and schematics, as well as a reference to compliance and service documentation. An example of a template for such a document is at Appendix 2 together with guidance on how it should be completed.

Where the CAA STC is a validation of a Major change from a non-UK applicant an alternative summary document specified by the certificating Authority can be accepted as long as it provides the equivalent information.

Certification Plan

The Team Leader will request the applicant to submit a certification plan, which describes the means by which compliance with the requirements of the Certification Basis affected by the change will be demonstrated, including any tests, together with the projected time-scales. Appendix 3 provides guidance on the information which should be provided by the applicant.

The plan will be reviewed by the Team for acceptability. The Team will discuss means of compliance with the applicant as necessary to ensure mutual understanding. The applicant will be required to set up a process to allow the status of each item in the certification plan to be tracked and recorded throughout the programme.

Compliance Record

The applicant will provide certification reports to the Team, which will formally record compliance with each applicable requirement. Team Members will be allocated the task of reviewing and accepting the reports by the Team Leader, having regard to their speciality and experience. Following a review of their decisions, the applicable compliance sheet will be closed, with a reference to any supporting reports, raised in issue, and circulated by the applicant. CAA Management involvement will be necessary where the proposed demonstration of compliance is controversial or where the applicant and Team are unable to agree.

Closed compliance sheets will be entered in the Compliance Record Document. An index of certification reports will be maintained by the applicant. The index should be regularly updated to show the CAA approval status. Copies of the certification plan and the report index will be retained by the CAA.

Witnessing of Tests and Physical Inspections

The test programme will be reviewed by the Team Leader who will determine with the Team which tests are to be witnessed, and physical inspections made. Team Members will be allocated specific tests and inspections. The applicant will be advised of this information in order that the Team Members concerned may be advised of test/inspection dates in good time.

Flight Testing

The UK Air Navigation Order (ANO) 2009 (as amended) Article 16 specifies the circumstances under which an aircraft may fly. When an aircraft is modified its Certificate of Airworthiness or Permit to Fly is rendered invalid until such time as the modification is approved by the CAA (ANO 2009 (as amended) Article 19). It follows therefore that an aircraft, which has modifications embodied which are not approved by the CAA may not fly except under specific flight testing provisions granted by the CAA.

The normal mechanism for the authorisation of exploratory test flights is for the organisation that proposes to conduct the flying to obtain a "permit to fly for test purposes" approval. Where it is necessary to conduct flight trials to establish compliance with the approval basis, and by implication to provide the evidence necessary to approve the modification, the permit must be in force throughout the trials.

Where there is already evidence of satisfactory flight characteristics, such as prior certification by the State of Design (for STC validations), or in the case of a modification it can reasonably be concluded that there will be no detrimental effect, flight testing may not necessarily be required for approval of the design. If nevertheless it is considered necessary to fly the aircraft in order to confirm correct functioning or performance, that flight will normally be carried out after approval of the STC.

Certification Meetings

The Team Leader will review progress with the applicant on a regular basis. If meetings are required the applicant shall issue minutes. The minutes will be circulated to Team Members as appropriate.

Documentation and Manuals

The applicant will provide supplements to manuals or documents required by the applicable requirements for approval by the Team.

Accomplishment instructions (e.g. Service Bulletins) will be prepared by the applicant and distributed as approved data. Approval of the instructions will be granted by the Team or through the applicant's design approval privilege when held.

6 Responsibilities of the Applicant

It is the responsibility of the applicant to define and record all activities leading to the issue of the STC. The applicant must determine the requirements that are applicable, and obtain the agreement of the CAA to the approval basis. The applicant must be satisfied that compliance with all of the applicable requirements has been demonstrated and that evidence of compliance, including assumptions and methods used, is recorded and retained. It is the responsibility of the applicant to provide to the CAA the information needed to complete the approval.

Efficient progression of the approval will be heavily dependent upon the timely submission of information, that is both complete and of good quality. Where the CAA has to make requests for clarification, correction or additional data this will inevitably delay the process and increase the staff hours expended by the CAA, in turn leading to higher charges. Where incomplete or poor quality information is submitted, the CAA may suspend the approval process and require the applicant to re-submit using an Approved Organisation having greater expertise and ability to complete the task.

The applicant should advise the CAA at the time of application of the proposed programme timescale, and of the proposed means of compliance with the approval basis. In this respect applicants are requested to note that the CAA commonly has no advance notice of the applications it receives and has to manage its finite resources to meet the diverse demands of the many and various applicants. Efficient management of resources is only possible if the timescale for each approval is reasonable, and allows for the inevitable multi-tasking of CAA staff.

7 STC Issue

After the Team has been satisfied by the compliance demonstration, the applicant will submit the final issue of the STC Definition Document and a final Compliance Checklist with a Declaration of Compliance to the Team Leader. These will be held on the CAA file. The Team Leader will then sign a Final Statement of Compliance. The CAA STC will then be issued to the applicant (Appendix 4).

8 Post STC Activities

Amendments to STCs are only allowed by the STC holder. The change will need to be classified Major/ Minor, and if major will follow a similar procedure as for the initial STC. A Significant change to an STC will require a new STC. The principles laid out in Part 21 will be followed where possible. The involvement of the Team will depend on the level of change.

INTENTIONALLY LEFT BLANK

Appendix 1 CAA Application Form

*Civil Aviation Authority
United Kingdom*

APPLICATION FOR SUPPLEMENTAL TYPE CERTIFICATE

This form should be completed and forwarded together with the appropriate fee, as notified in the Current CAA Airworthiness Scheme of Charges, to: Civil Aviation Authority, Airworthiness Division, Application and Approvals Department, Aviation House, Gatwick Airport South, West Sussex RH6 0YR.

Applicant:		Tel No:	
Address:		Fax No:	
		E-Mail:	
Post Code:			
Aircraft/Product Type:			
TCDS Ref:			
Location of aircraft for inspection:		Applicant Modification No:	
Proposed Classification: Significant/Non-Significant		Design Organisation:	
Justification:		CAA Approval Ref:	
		Production Organisation:	
		CAA Approval Ref:	
STC Title:			
Requested Date for STC Issue:			
Flight Manual Affected (delete as applicable):		Arrangement with TC Holder (delete as applicable):	
Yes/No		Yes/No	
I hereby declare that the above particulars are true in every respect. I agree to pay any further charges in connection with this application, which may be notified by the CAA, including costs subsequently incurred by the CAA for work carried out on post-certification activities. I understand and accept that the STC, when issued, will be published in databases accessible to the public.			
Signature:		Name:	Date:
		Position:	

Reserved for CAA use only			
£	ACP Number	Action	Project No.
Received by		Surveyor	Date
Date		Regional Office	Initials

Appendix 2 STC Definition Document

Applicant		Document Ref:	
		Issue:	Date:
CAA Design Approval Ref:		Page 1 of	
CAA UK SUPPLEMENTAL TYPE CERTIFICATE DEFINITION DOCUMENT		CAA Project Ref:	
		SIGNIFICANT	NON-SIGNIFICANT
		Delete as appropriate	
Product Modified:			
STC Title/Description:			
CAA Production Approval Ref:			
Certification Basis:			
Requirements Affected:			
Compliance Plan Ref:			
Compliance Record Ref:			
Drawing List:			
Manuals Affected/ Supplement Ref:	Flight Manual		
	Airworthiness Limitations		
	Maintenance Manual		
	Maintenance Schedule		
	Electrical Load Analysis		
	MMEL		
	Weight & Balance Manual		
Accomplishment Instructions Ref:			

Guidance Notes for Compiling STC Definition Document.

Applicant	Company name of applicant for STC.
Document Reference	Applicant internal reference number for STC Definition Document that could be used as referenced data on the STC when issued.
CAA Design Approval Reference	Applicant's Design Approval reference.
CAA Project Number	The CAA Project reference number will be supplied by CAA. This will be the internal CAA tracking number pending the granting of the CAA STC.
Significant /Non-Significant	Delete as appropriate. STCs are classified from a procedural point of view into Significant and Non-Significant. A Significant STC is a major design change that necessitates a change to the Certification Basis of the basic Product, as referenced in its Type Certificate Data Sheet. A Non-Significant STC is any other STC.
Product Modified	The Product changed by the STC. The full Type/Variant designation should be given.
STC Title/Description	Title of STC. This should include a brief description of the STC to clearly summarise the physical changes to the Product.
CAA Production Approval Reference	The applicant should identify the production organisation(s) that will receive approved data and assistance in order to permit production of airworthy parts eligible for installation as part of the STC.
Certification Basis	Reference should be included to a document presenting the Certification Basis of the Product being changed, generally the Type Certificate Data Sheet. The Certification Basis identifies the applicable standards against which the applicant must show the proposed change complies.
Requirements Affected	<p>Reference is required to all those requirements of the Certification Basis, including environmental requirements i.e. noise and emissions, affected by the change and for which a compliance statement is required to be included in the Compliance Record.</p> <p>In addition, design requirements that must be complied with in order that operational requirements can be satisfied should be included e.g. JAA TGLs for BRNAV, EGPWS, RVSM and any specific design requirements relating to equipment required by operational rules such as JAR-OPS.</p>
Compliance Plan Reference	<p>Reference to the compliance plan should be included. The plan itself should provide at least the following for each compliance subject:</p> <ul style="list-style-type: none"> • Affected Requirement (CS, BCAR etc.) and its amendment level; • Means of Compliance, e.g. calculation, test, design review, inspection etc. <p>Any specific flight testing provisions required to be granted by CAA, reference BCAR A8-9, should be noted in the plan.</p>

Compliance Record Reference

Reference to the compliance record (which itself should include reference to all compliance reports) should be included.

Drawing List

This must include all drawings introduced by the change. Where there is a significant number of drawings, reference to a Master Drawing List is acceptable, as long as this provides a ready reference to all the other drawings.

Manuals Affected

All manuals affected should be indicated by inclusion of a reference to the required supplement/amendment.

Accomplishment Instructions

Reference to the accomplishment instructions document provided to installers of the STC should be included.

INTENTIONALLY LEFT BLANK

Appendix 3 Guidance for Compilation of Certification Documents

The following should be used as an aid when determining the content of the Certification document(s) required by the STC procedures. The applicant should agree the specific project documentation with the CAA.

Applicants may decide whether to compile one or more documents which contain this information. As the project progresses the document(s) will be maintained jointly by the applicant.

Applicant's Certification Personnel	Name and contact details of key personnel involved in programme, e.g. programme manager, technical and airworthiness staff, and design signatories with their specialisation accepted by CAA.
Description of Modification	This should include a system/configuration definition with associated drawings, diagrams, and schematics to summarise the physical change to the aircraft.
Liaison with Production	The applicant should identify the production organisation(s) that will receive approved data and assistance in order to permit production of airworthy parts eligible for installation as part of the STC. This should also include, as necessary, details of the parts approval status and a conformity inspection plan.
Operator Focal Point	Name and contact details of the operator's representative(s).
Aircraft and Location	Details of the aircraft and its location for inspection/certification purposes.
Foreign Aviation Authority	Details of any foreign aviation authority involved in the STC approval process.
Arrangement with Type Certificate Holder	Details of any arrangement entered into with the Type Certificate Holder in support of the STC application where applicable.
Certification Schedule	A schedule of certification activities that will be agreed between the CAA and the applicant and maintained by the applicant through the programme.
Certification Basis	The Certification Basis identifies the applicable standards to which the applicant must show compliance. It also includes the need for special conditions, exemptions, and equivalent safety findings, if any. An issues list should be included to highlight for resolution those special requirements and other areas that may be significant, even though they may not warrant a special condition, exemption, or equivalent safety finding. Reference should also be made to the applicable CAA design requirements for the issue of a Certificate of Airworthiness.

Operational Requirements	Identification of the design requirements that must be complied with in order that operational requirements can be satisfied. For example: JAA TGLs for BRNAV, EGPWS, RVSM and any specific design requirements relating to equipment required by operational rules such as JAR-OPS.
Environmental Requirements	The applicable noise and emissions requirements.
Compliance Matrix/ Check List	A table listing for each affected part of the aircraft: a) the compliance subject; b) the applicable requirement (BCAR etc.) and its amendment level; c) the method of compliance, e.g. calculation, test, design review, inspection etc.
Test Requirements	Details of the various tests identified in paragraph 12 above (e.g. laboratory, ground, flight etc.) together with planned test locations, approval of test facilities, and dates. This section should contain any requirements for the planning, preparation, and conduct of flight testing. The applicant should identify the need for any specific flight testing provisions to be granted by CAA.
Compliance Documents	A list of the compliance documents that will be produced including the document/ drawing reference number, title, applicable requirement, and proposed submittal date where applicable.
Manuals	Specification, or reference to a document specifying, changes to documents and placarding. Commonly this may include: a) Flight Manual; b) Maintenance Manual; c) Airworthiness Limitations; d) Maintenance Schedule; e) Electrical Load Analysis; f) MMEL; g) Weight and Balance Schedule; h) Type Certificate Data Sheet(s).
Instructions for Continued Airworthiness	A statement of, or reference to documents defining, any inspections or other actions required to maintain airworthiness in-service.

INTENTIONALLY LEFT BLANK

Leaflet C-160 Continuing Airworthiness Responsibilities for Owners/Operators of Aircraft with an EASA Certificate of Airworthiness not used for Commercial Air Transport

1 Introduction

- 1.1 This Leaflet is intended to explain the responsibilities set out in paragraph M.A.201 of Part M for the owners of aircraft that are not defined as a large aircraft¹ when not used for Commercial Air Transport (CAT). It is also intended to set out the options that the Regulation provides to contract certain responsibilities from the owner/operator to approved Continuing Airworthiness Management Organisations (CAMOs).
- 1.2 Commission Regulations (EC) 2042/2003 (Annex 1) and (EC) 1056/2008 came into force on 28 September 2003 and 27 October 2008, respectively. These regulations, which are collectively known as Part M, place responsibility on an aircraft owner for ensuring that no flight takes place unless their aircraft:
- a) conforms to an EASA-recognised type design; and
 - b) has all modifications and repairs approved in accordance with Part 21; and
 - c) is maintained in a condition for safe operation; and
 - d) is operated within the limitations of the approved flight manual.

2 Background

- 2.1 Paragraph M.A.201 (a) of Part M states:
- 'The owner is responsible for the continuing airworthiness of an aircraft and shall ensure that no flight takes place unless:
- 1 the aircraft is maintained in an airworthy condition; and
 - 2 any operational and emergency equipment fitted is correctly installed and serviceable or clearly identified as unserviceable; and
 - 3 the airworthiness certificate remains valid; and
 - 4 the maintenance of the aircraft is performed in accordance with the approved maintenance programme as specified in M.A.302.'
- 2.1.1 Part M provides options for the owner/operator in relation to this continuing airworthiness management responsibility. These are detailed in Section 3 below.

3 Owner/Operator Continuing Airworthiness Management Options

- 3.1 Continuing Airworthiness tasks are listed in Part M, M.A.301 and M.A.302 and require:
- a) the accomplishment of pre-flight inspections;

1. A large aircraft is any aeroplane with a maximum take-off mass exceeding 5700 kg, or a multi-engined helicopter.

- b) the rectification to an officially recognised standard of any defect and damage affecting safe operation taking into account, for all large aircraft or aircraft used for commercial air transport, the minimum equipment list and configuration deviation list if applicable to the aircraft type;
- c) the accomplishment of all maintenance in accordance with the approved aircraft maintenance programme;
- d) the accomplishment of any applicable:
 - i) airworthiness directive;
 - ii) operational directive with a continuing airworthiness impact;
 - iii) continuing airworthiness requirement established by the Agency;
 - iv) measures mandated by the Competent Authority in immediate reaction to a safety problem.
- e) the accomplishment of modifications and repairs in accordance with M.A.304;
- f) maintenance check flights when necessary.

3.2 **Option 1: The owner may contract a suitability approved CAMO**

- 3.2.1 In this case, the responsibility to perform the tasks associated with continuing airworthiness management are transferred to the CAMO. Under these arrangements, the aircraft, if maintained in accordance with the requirements of Part M will, after 12 months, be considered to be in a controlled environment¹.
- 3.2.2 The controlled environment provides a high level of assurance that all applicable continuing airworthiness management tasks are properly planned, accomplished and recorded. Aircraft in this environment benefit from being able to have the period of validity of their Airworthiness Review Certificates (ARC) extended twice, rather than requiring a full airworthiness review to be performed annually.
- 3.2.3 For those aircraft in a controlled environment, an Airworthiness Review is only required every three years. For the second and third year, the contracted CAMO can extend the ARC for a year each time.

3.3 **Option 2: The owner may enter into a limited contract with a CAMO for the development of the Aircraft Maintenance Programme**

- 3.3.1 The limited contract transfers the responsibility for the development and approval of the Aircraft Maintenance Programme to the contracted CAMO only. The owner still retains responsibility for all other continuing airworthiness tasks. Under these circumstances, the aircraft will not be in a controlled environment.
- 3.3.2 An aircraft not managed within a controlled environment must have a full Airworthiness Review carried out, and be issued with an ARC, on an annual basis. For aircraft not exceeding 2730 kg, this may be done by a CAMO. For aircraft exceeding 2730 kg, the CAMO can carry out the Airworthiness Review but will have to make a recommendation to the CAA for an ARC to be issued.

1. An aircraft is in a controlled environment when it has been continuously managed by the same CAMO for the preceding 12 months and has been maintained by a Part 145 or Subpart F organisation, except for permitted pilot maintenance tasks (accomplished by the owner of the aircraft or an independent Part 66 licensed aircraft engineer).

3.4 **Option 3: The owner/operator may manage all the Continuing Airworthiness tasks themselves**

- 3.4.1 When choosing this option, the aircraft will not be in a controlled environment and will require a full airworthiness review every year. The owner/operator remains responsible for all aspects of continuing airworthiness management.

4 **Continuing Airworthiness Management Contracts**

- 4.1 Where a contract has been put in place between the owner and a CAMO under Option 1, the contract should take into account the requirements of Part M. The contract shall define the obligations of the signatories in relation to the continuing airworthiness of the aircraft.

- 4.2 The contract shall also specify the aircraft type, the aircraft registration and serial number, the aircraft owner or registered lessee's name or company (including their address as a minimum) and the approved CAMO details, including their address.

- 4.3 The contract shall include the following (extract from Appendix I to Part M):

'The owner entrusts to the approved organisation the management of the continuing airworthiness of the aircraft, the development of a maintenance programme that shall be approved by the airworthiness authorities of the Member State where the aircraft is registered, and the organisation of the maintenance of the aircraft according to said maintenance programme in an approved organisation.

According to the present arrangement both signatories undertake to follow the respective obligations of this arrangement.

The owner certifies, to the best of their belief that all the information given to the approved organisation concerning the continuing airworthiness of the aircraft is and will be accurate and that the aircraft will not be altered without prior approval of the approved organisation.

In case of any non-conformity with this arrangement, by either of the signatories, it will become null. In such a case, the owner will retain full responsibility for every task linked to the continuing airworthiness of the aircraft and the owner will undertake to inform the competent authorities of the Member State of registry within two full weeks.'

INTENTIONALLY LEFT BLANK

Leaflet C-170 EASA Aircraft with an Expired UK (National) Certificate of Airworthiness

1 Introduction

- 1.1 The European Aviation Safety Agency (EASA) initial airworthiness regulations published in 2003 specified that by 28 September 2008, all aircraft subject to European regulations should be issued with a non-expiring EASA Certificate of Airworthiness (CofA), supported by an Airworthiness Review Certificate (ARC).
- 1.2 There are currently a number of UK-registered EASA aircraft that have not been issued with a non-expiring EASA CofA and an ARC. In all cases, the national CofA has now expired and cannot be renewed under national rule provisions.
- 1.3 This Leaflet sets out CAA policy on the actions required by aircraft owners and their Continuing Airworthiness Management Organisations (CAMOs) to enable EASA-format documents to be issued.

2 Procedure

- 2.1 Owners of aircraft who wish to obtain a non-expiring EASA CofA and initial ARC should apply to the CAA's Applications and Approvals Department using application Form CA3, available from the CAA website at www.caa.co.uk/ca3. The completed application form should include details of any event that may have affected the airworthiness of the aircraft, and particulars of any modification or structural repair accomplished since the last renewal of the CofA.
- 2.2 To enable a recommendation to be made to the CAA for ARC issue, the applicant will need to arrange for any outstanding maintenance to be accomplished and for an airworthiness review to be completed by a suitably approved Part M Subpart G organisation (CAMO) holding ARC privileges or for ELA1 category aircraft, by a licensed engineer holding an ELA1 approval issued by the CAA.
- 2.3 In all cases the CAMO, or ELA1 approval holder, should determine if a maintenance check flight is necessary prior to final CofA issue. An EASA Permit to Fly will be required to enable a check flight to be accomplished and application for this should be made concurrently with the application for an EASA CofA and ARC (Form CA3). The airworthiness review signatory should record the details of the check flight performed, any defects observed and the corrective actions taken, as part of the documentation raised to support the recommendation to issue the ARC.

NOTE: While the CAA reserves the privilege to conduct an aircraft survey, if required, the following principles will be applied:

- For aircraft where the CofA expired prior to 28 September 2003, a CAA Regional Office Surveyor will survey the aircraft prior to issuing the replacement documents.
- For aircraft where the CofA expired after 28 September 2003, a CAA survey will not normally be required and EASA documents will be issued following receipt of the CA3 and the recommendation to issue an ARC.

INTENTIONALLY LEFT BLANK

Leaflet C-180 Control of Production Suppliers and Subcontractors

(This amendment updates the CAA process for the identification of suppliers for witness assessment and advises information to be contained in the Company Exposition to allow the UK CAA to plan witness assessments of suppliers in a coordinated manner consistent with the principles of Performance Based Regulation).

1 General

- 1.1 As the UK Competent Authority for production, the CAA is required by GM No.3 to 21B.220(c) to define a clear procedure for supplier control for those organisations with facilities / partners / suppliers / subcontractors located in a third country on the basis of Part 21. As a result of recent experience and with the increased globalisation of the supply chain, it has been decided to establish a common procedure applicable to CAA approved production organisations and their facilities / partners / suppliers and subcontractors located within the UK or in another country. In order that the CAA policy is clearly understood both internally and by Industry, it has been decided to establish this Leaflet, the contents of which have been declared to EASA.
- 1.2 If outsourced production activity is completely conformed on receipt at a Production Organisation Approval Holder (POA Holder), for example dimensional inspection of machined parts manufactured from material supplied by the POA Holder, then this constitutes control under the POA Holder's quality system and no further action in accordance with this Leaflet is necessary.
- 1.3 The controls of this Leaflet apply where it is either not possible to verify conformance on receipt (for example completed assemblies, embedded and supplied software, special processes, treatments, welding etc.), or where the POA Holder chooses not to verify on receipt but to place reliance on quality control/quality assurance activity carried out by the supplying organisation.
- 1.4 POA Holder facilities located in another country (i.e. where the overseas production activity is undertaken in a factory which is part of the POA's own organisation) are considered part of that POA and must be listed on the Terms of Approval (EASA Form 55). These additional sites will be subject to routine CAA surveillance in accordance with a Surveillance Plan. To maintain compliance with Part 21 Section B, overseas facilities must be visited by the CAA a minimum of at least once in every two year renewal cycle of the POA.

Where the facility is undertaking production of particular significance to airworthiness, such as critical parts (see Definitions) or other parts the failure of which are considered by the Design Holder to cause a situation of hazardous or higher, then the CAA may require to visit more frequently. Direct oversight of these facilities is undertaken in accordance with CAA Internal Procedures and will not be further considered within this Leaflet.

- 1.5 Part 21A.139 (a) states that a POA's quality system "shall be such to enable the organisation to ensure that each product, part or appliance produced by that organisation or by its partners, or supplied from or subcontracted to outside parties, conforms to the applicable design data and is in condition for safe operation...." This means that every item produced or procured and every process used in the production of an item covered by the holder's POA is the responsibility of the POA whether at the POA's own facility or from other sources. This includes tier 1 suppliers and all other sub-tiers of the supply chain.
- 1.6 Particular care must be exercised to ensure that unauthorised changes are not introduced as a result of this extended supply chain. As a reminder all such changes (including unplanned changes such as concessions) to applicable design data must be approved under the Part 21 DOA system either directly by the Agency or more normally via a DOA Holder. Where the POA Holder is not the DOA Holder for the product, part or appliance being manufactured, then the request for change at any level of the production change must be formally addressed via the DOA / POA interface arrangements required by 21A.133(b). These arrangements may allow the classification and acceptance of low-level concessions/changes by personnel at POA Holder level, but only where specifically delegated by the DOA Holder with the arrangements referenced in the DOA Handbook and the POA Holder's Exposition.
- 1.7 To demonstrate control of the supply chain, a POA must identify those suppliers used (generally by means of an approved supplier list) and establish a philosophy for the control of each supplier based on the type, complexity and risk to airworthiness of the items procured.
- 1.8 Aerospace production organisations are increasingly taking an international approach to business to reduce costs and open new markets. As a result more complex items are being procured from overseas and by smaller organisations with less dedicated supplier oversight resource than before. These extended supply chains can constitute a risk to the level of overall control, including the introduction of uncontrolled processes and unauthorised materials. On the basis of information provided by the POA Holder and defined within the Exposition, the CAA POA team leader should ensure that the continued surveillance plan adequately addresses all places

where significant production is carried out regardless of geographical location to meet the intent of this Leaflet.

- 1.9 Where a POA places production work orders with other organisations (either a partner, supplier or subcontractor located in the UK or overseas), then Industry and CAA oversight is to be conducted in accordance with this Leaflet.
- 1.10 Where a partner, supplier or subcontractor is located in another country, the UK CAA may decide to reach an arrangement by which the local National Aviation Authority (NAA) agrees to undertake surveillance on behalf of the CAA. In such cases the arrangements will be defined as laid down in GM No. 4 to 21B.220(c) and reported to the CAA using an EASA Form 58A. Where no such arrangements exist, the CAA will undertake oversight in accordance with this Leaflet. In the latter case, the local NAA should be advised of the activity and may wish to attend as an observer.
- 1.11 Where the CAA decides to exercise direct oversight of a partner, supplier or subcontractor, it is important to note that such visits are independent of the surveillance activity undertaken by the POA Holder. A POA Holder may not rely on surveillance carried out by the CAA to simplify its own tasks or to replace or reduce its own oversight (GM No.3 to 21B.220(c) refers), and remains responsible for the activities of the subcontractor.

2 Definitions

For the purposes of this Leaflet the following definitions are adopted:

- 2.1 **Partner.** Another organisation with which the POA Holder has an arrangement as part of a joint venture or similar agreement, or a sister or parent organisation within the same group of companies but outside the POA itself. The term 'partner' has no effect on the extent of oversight needed to determine conformity of parts being provided to the POA Holder. Unless the partner organisation holds a Part 21 G approval and is 31 October 2012 supplying via an EASA Form 1, then the receiving POA organisation is still responsible for exercising supplier oversight. In order to reduce the overall surveillance burden, partnerships may wish to consider "shared second party" activity as defined in paragraph 7.
- 2.2 **Supplier.** As per GM No. 2 to 21A.139(a), a supplier is another organisation which holds a POA and which provides an authorised release certificate (EASA Form 1) or equivalent (see Note below). The receiving POA Holder may rely on the incoming Form 1 and reduce surveillance to "a satisfactory demonstration of interfaces" i.e. conforming that the supplier has a scope of

approval that includes the supplied items, that the purchase order clearly identifies the POA Holder's requirements and that conformance with these requirements is checked on receipt.

NOTE: This also includes an authorised release certificate received from an organisation based in a State with which there is an applicable bilateral agreement (such as an 8130-3 received from an organisation holding FAA production approval).

2.3 **Subcontractor.** In GM No. 2 to 21A.139(a), EASA defines a subcontractor as any supplying organisation that does not hold a Part 21 Subpart G. For the purposes of this Leaflet, a distinction is drawn between a true **Subcontractor** – i.e. an organisation that is undertaking part of the normal production process that the POA Holder has decided to contract out (such as casting, machining, assembly, welding, treatments, processing etc.) and a **Vendor** (see below).

2.4 **Significant Subcontractor.** A significant subcontractor is one on which the capability of the POA Holder is dependant or where the contracted activity is considered significant to airworthiness. Significant subcontractors are to be listed in the Exposition, and a change to that list or to the placement of significant subcontracted items is required to be notified to the CAA by means of an EASA Form 51 and approved in accordance with 21A.147.

2.4.1 Significant items are those such as critical parts or other parts the failure of which are considered by the Design Holder as likely to cause a situation of 'hazardous' or higher as a result of a Functional Hazard Analysis/System Safety Assessment under CSxx.1309 (e.g. CS 25.1309) or equivalent regulation.

NOTE: Further guidance regarding classification of critical parts is contained in <http://easa.europa.eu/the-agency/faqs/regulations#category-initial-airworthiness>. In case of any doubt in classification, reference must be made to the DOA Holder identified in the Design/Production Interface arrangement for the part concerned.

2.4.2 As an example, the CAA would not expect to be notified of a change of subcontractor for routine machining on a non-structural part within the approved supplier list, but would expect to be advised of a change involving transfer of structural composites involving bespoke tooling and controlled processes. Similarly the transfer of production of parts to a subcontractor outside of the UK with which the POA Holder had no prior involvement would also constitute a significant change requiring prior approval from the CAA.

NOTE: In the case of complex organisations with numbers of significant parts within the supply chain (such as Type Certificate Holders), Para 2.4 could result in a large number of Variation Applications being generated during a surveillance cycle. In such cases, the responsible Surveyor may agree a process where intended product transfers are notified during regular interface meetings but a Variation is only required where the CAA intends to undertake direct sampling of the change. Where agreed, such a process should be documented in the Exposition and minutes of meetings maintained as a record of the notification and resulting decision on whether a Variation is required.

- 2.5 **Vendor.** A supplying organisation providing incoming materials, catalogue parts, standard parts and consumables used as part of the production activity. The CAA's policy for the acceptable control of these types of supplying organisations is contained within Section 6 of this Leaflet.
- 2.6 **COTS (Commercial off the Shelf) Equipment.** The CAA's policy for COTS equipment and parts incorporated into aerospace installations is detailed in CAP 562 Leaflet B-110, entitled 'The Acceptance of Aircraft Components'. Where such parts are provided by organisations not holding a POA themselves, compliance is generally demonstrated by means of a Quality Plan placed on the supplying organisation by the POA Holder to demonstrate conformance to the design data.
- 2.7 **Direct Oversight.** Where the CAA decides to undertake surveillance activity at a facility / partner / supplier / subcontractor located in a third country rather than delegate to the local NAA (for example: because there is no arrangement with the NAA or because the facility/partner/supplier/subcontractor holds no local approval).
- 2.8 **Product Audit.** 21A.139(b)(2) requires the POA Holder to demonstrate "systematic evaluations or audits of factors that affect the conformity (and where required, safe operation) of the products, parts or appliances and/or materials to the applicable design".

While audits of the quality system are an essential part of this process, on their own they do not address the need to provide evidence of conformity to the design data for parts released under the 21A.163 privileges.

A Product Audit is a determination that the physical conformity, manufacturing processes and results of product acceptance testing of a product, part or appliance show compliance with the design data. This can be via direct inspection, or more normally by observation of dimensional examination, review of in-process activity or repeat acceptance testing to show compliance with the data.

Industry has established standards such as AS9102 First Article Inspection Report (FAIR) to assist in documentation of the results of physical inspection and these reports, which list each dimension on the drawing and record the value obtained during inspection, can be used as supporting evidence. A product audit will also review conformity records such as raw material certificates, availability and accuracy of process and routing documentation, appropriate closure of production noncompliances, evidence of compliance to special process requirements (Product Acceptance Test reports, NDT reports, treatment records, results of chemical and mechanical testing etc.) to provide assurance that production activity remains in compliance with the manufacturing data package generated to meet GM 21A.145(b)(2).

- 2.9 **CAA Supplier Governance Board.** The CAA has established a Supplier Governance Board, chaired by the Head of Airworthiness, to ensure that CAA supplier oversight is proportionate and consistent across UK POAs and to ensure that CAA resources are used in the most effective manner by combining surveillance activities wherever possible.

3 Exposition

- 3.1 21A.143 requires the Exposition to include a list of outside parties which are used as suppliers or subcontractors to the POA. As this list may run to several hundred companies and is subject to frequent change, it is normal for the Exposition to crossrefer to an external document such as a company Approved Supplier List.
- 3.2 While this is acceptable, the Exposition should specifically identify those significant sub-contractors on which the capability of the POA Holder is dependent and a change of which would be expected to be advised to the CAA via an EASA Form 51 as a significant change.
- 3.3 The Exposition should include a summary of the process that the POA Holder uses to control suppliers, subcontractors and vendors and describe the means by which the POA Holder distinguishes between these categories of supplying organisations for purposes of oversight. This process should not be based purely on the basis of commercial risk (such as spend with a specific company) but should include an assessment of the significance to airworthiness of the parts concerned in considering allocation of supplier surveillance resources.
- 3.4 The Exposition should cross-refer to the detailed quality procedures for the conduct of supplier oversight, and to the internal procedures that ensure that “changes in the placement or control of significant sub-contracted work or supplied parts” are notified to the CAA for approval as required by GM
-

21A.147(a). In the context of this Leaflet this means change in Significant Subcontractors. (See definition in paragraph 2.4).

- 3.5 Where a POA Holder intends to extend certifying staff privileges to subcontractor personnel, then it should be ensured that such personnel are trained and nominated in exactly the same manner as those directly employed by the POA. These nominees are to be specifically identified in the Exposition, and a proposal to extend such privileges to a new subcontractor must be reported to the CAA as a significant change prior to implementation.
- 3.6 Where the POA Holder intends to use other parties in accordance with paragraph 7 of this Leaflet this should be specifically identified in the Exposition.
- 3.7 The POE should define the resources required to manage and carry out supplier control, in particular allocation of the manpower.
- 3.8 In order to allow the CAA to plan allocation of witnessed assessments of supplier on the basis of risk and to make best use of resources by combining overseas visits wherever possible, the POE should include the following table with data completed by the POA Holder. The CAA will assess this information and allocate a rating in accordance with Para 4.4 to guide the number of witness assessments at suppliers it will undertake during the surveillance cycle.

Approximate Percentage of Production Contracted	
Approximate Number of Batches delivered by Subcontractors	
Approximate Number of UK Subcontractors	
Number undertaking critical activity (UK)	
Approximate Numbers of Overseas Subcontractors	
Number undertaking critical activity (Overseas)	
Full Time Equivalent (FTE) Personnel undertaking Supplier QA Activity	
Number of On-Site Audits undertaken annually	

4 Routine Oversight of Subcontractor Control

- 4.1 At the point of initial approval for Part 21 Subpart G, and on a two-yearly basis at the time of completion of the EASA Form 56 renewal recommendation,

the CAA will determine the extent to which the POA Holder uses external subcontractors and allocate a rating as follows:

None: The POA Holder undertakes all production activity in-house apart from the purchase of materials and consumables from vendors.

UK: The POA Holder uses subcontractor organisations within the UK for production and / or processing activity.

International: The POA Holder operates a global supply chain management system.

4.1.1 This rating will be used to determine the CAA's expectation of the resource allocated to supply chain management and also to assist in determine the resource allocated by the CAA in its oversight of that control.

4.2 In order to meet 21A.145(a), the POA Holder is required to demonstrate that the general organisation and numbers and competence of staff is sufficient to discharge the obligations under Part 21. To do this, a supplier/subcontractor control Manpower Plan is to be provided to the CAA POA Team Leader describing the following:

- a) Manager Responsible;
- b) Allocated Company Resources;
- c) Visit Plan, including:
 - i. Quality Management System Assessment;
 - ii. Arrangements for Product Audit.

This Plan is to be updated every two years at the time of recommendation of the renewal of the approval, and updated for Team Leader approval in the case of significant change (numbers of staff, new subcontractors providing parts of airworthiness significance and new overseas subcontracts) within that period.

4.3 The CAA baseline expectations of the Manpower Plan are as follows:

UK: Resource normally based on allocation of responsibility to Quality Manager and access to sufficiently qualified Supplier Quality Engineers who will normally have other responsibilities.

International: Management of overseas supply chain generally requires a step change in resources, principally the availability of staff to undertake sufficient oversight visits addressing QMS and product aspects.

The expectation for control of an overseas supply chain is that the responsible manager will have access to dedicated resource for oversight, supplemented by access to personnel with specific technical knowledge related to the product. This should include either the presence of locally based personnel to undertake QMS and product audits at the subcontractor, or sufficiently frequent and thorough audits from the main POA facility to ensure that conformity to the design data is assured.

- 4.4 The CAA oversight by means of witnessed assessment of a subcontractor control audit will be based on the information provided in the Exposition under Para 3.8 of this Leaflet and the allocated rating as follows:

Those organisations where the level and criticality of supplier activity is assessed as LOW will be subject to a minimum desktop assessment of the supplier quality system once during the 2 year renewal cycle.

Those organisations where the level and criticality of supplier activity is assessed as MEDIUM will be subject to a minimum desktop assessment of the supplier quality system once during the 2 year renewal cycle and a minimum of 1 CAA witnessed audit visit within the supply chain per 2 year renewal cycle.

Those organisations where the level and criticality of supplier activity is assessed as HIGH will be subject to a minimum desktop assessment of the supplier quality system once during the 2 year renewal cycle and a minimum of 2 CAA witnessed audit visits within the supply chain per 2 year renewal cycle.

When identifying suppliers for the witness visit, priority will be given to subcontractors undertaking activities of airworthiness significance (i.e. critical parts / process subcontractors) and those which have not been previously visited by the CAA.

Where an organisation's supply chain includes a significant element of overseas activity (i.e. International under Para 4.1), this should also be taken into consideration when selecting the supplier for witness assessment with priority being given as above. Note: CAA costs associated with overseas surveillance visits are recoverable from the POA Holder.

NOTE: The POA Team Leader may decide to vary the above frequency based on an understanding of the risks associated with the organisation. The frequency may be reduced (for example where the organisation is sub-contracting work of low airworthiness significance) or increased (for example where the CAA is aware of conformity problems associated with subcontracted work). In such cases the justification should be recorded on the Form 56 supporting the Continued Surveillance plan and agreed by the responsible Airworthiness Manager prior to notification to the CAA Supplier Governance Board.

4.5 The CAA oversight generally takes the form of two stages as follows:

Stage 1: Review of supply chain control data held by the POA Holder. This may include review of oversight philosophy and risk assessment, procedures, assessment checklists, quality plans, results of audits and subsequent follow-up, review of supplied documents such as Product Acceptance Test and First Article reports, inspection reports etc.

Stage 2: On-site review as defined in Paragraph 5 below.

In the case of low airworthiness risk or previous demonstration of a high standard of supplier control, the POA Team Leader may decide that Stage 1 alone is sufficient for a particular audit cycle. Again, this justification should be recorded on the Form 56 and agreed by the responsible Technical Manager Airworthiness.

5 Change of Significant Subcontracted Work – CAA Investigation

5.1 A change in placement or control of significant sub-contracted work or supplied parts constitutes a significant change to the Part 21 approval and must be notified to the CAA via an EASA Form 51 prior to implementation. In the context of this Leaflet this means change in Significant Subcontractors (see definition in paragraph 2.4). Where a POA Holder is in doubt over the need to formally notify the CAA, then contact should be made with the POA Team Leader for advice.

5.2 POA Holders will normally be expected to provide a transition plan for the specific proposal addressing the following elements:

- a) Person within the POA with responsibility for coordinating the transition of the subcontract activity and acting as a focal point for communication with the CAA;

- b) Airworthiness significance of the items being subcontracted;
- c) Extent of previous knowledge of the subcontractor concerned;
- d) Maturity of production processes and techniques being subcontracted, any unique or novel features or emerging technologies being employed;
- e) Key milestones, including timescales for on-site assessment by the POA Holder of technical capability, Quality Management System assessment and Product Audit;
- f) Identification of responsible POA Holder personnel including technical / engineering, quality assurance and commercial;
- g) Arrangements for Last Article/First Article Inspections conducted by the POA Holder and at the subcontractor;
- h) Checks / calibration of inspection aids and production tools and fixtures either held by the subcontractor or relocated from the POA Holder;
- i) Control of special processes, including validation/qualification against original POA Holder methods;
- j) Arrangements for the retention of production records (both physical records such as travellers and test reports and computer records such as CNC programmes and CMM inspection data);
- k) Arrangements for control of lower tier subcontractors, such as raw material supply and external treatments;
- l) Any intention to nominate Certifying Staff at the subcontractor rather than return the parts to the POA Holder for release;
- m) Establishment of Competent Authority right of access.

5.3 Based on the information supplied by the POA Holder, the POA Team Leader will advise the extent of CAA investigation needed based on an assessment of the airworthiness risk of the parts being supplied and prior experience of that POA Holder with the subcontractor concerned. Using this risk-based approach, the Team Leader will decide whether:

- a) to undertake a witness CAA visit to the subcontractor prior to their undertaking any work; or

- b) to conduct a visit as part of routine surveillance within a specific period; or
- c) the extent of the subcontracted activity is such that direct CAA oversight is not required.

This decision should be advised to the POA Holder in writing and a copy retained by the UK CAA.

- 5.4 Where the Team Leader identifies that on-site witness of the POA Holder's control of the subcontractor is required, then consideration should be given to requesting Specialist support where the Team Leader does not have specific experience (such as Materials, Treatments, Hydro-mechanical and Fuel Systems, Avionics, Software etc.).
- 5.5 In conducting an on-site witness, the CAA is conducting an investigation of the POA Holder's quality system for the oversight of its supply chain, not replacing the POA Holder's own assessment. It therefore follows that any non-compliances identified during the process must be directed to the POA Holder and not to the subcontractor.

Prior to the on-site visit, the POA Holder should provide the POA Team Leader with information regarding the proposed assessment team and the intended audit plan to demonstrate that the following elements are being addressed. Any concerns expressed by the POA Team Leader regarding the intended plan or personnel should be addressed prior to committing the resource to undertake the visit.

- a) Quality System elements of 21A.139 (a), including:
 - Technical evaluation of supplier's capability;
 - Control of special processes;
 - First Article inspection;
 - In process inspections and production acceptance testing;
 - Completion of Conformity documentation;
 - Traceability;
 - Incoming Receipt of materials and parts;
 - Personnel Training and Competence;
 - Records control including retention and archiving;
 - Effectiveness of supplier's internal auditing system.
- b) Flow-down links to design data to meet 21A.133 (b) and (c).
- c) Control of sub-tier subcontractors (where permitted).

-
- d) Reporting of non-compliances to the POA Holder, including material and process changes, material substitutions, concessions and errors found after delivery of items.
 - e) Product Audit – i.e. the assessment should not rely entirely on procedural review but include assessment at shop floor level to ensure that the procedures are actually being applied in practice and compliance with design data is shown. This may include a repeat of physical dimensional examination or product acceptance testing in the presence of the audit staff, as well as an examination of quality records recording the results of previous conformity examinations.
 - f) Purchase Order / Contract review to ensure compliance with 21A.145 general requirements (resources including adequate facilities, personnel, equipment etc.) and regulator right of access to support 21A.157.
- 5.6 During the visit, the CAA surveyor will assess, either by observation of the POA staff or by direct questioning that the Part 21 elements listed in 5.5 above have been addressed.
- 5.7 Where the CAA becomes concerned that the conduct of the subcontractor assessment is of insufficient depth to demonstrate compliance with the Part 21 requirements, this should be identified to the POA Holder personnel as soon as possible during the visit so that the organisation has the opportunity to change its focus. The intent of identifying concerns at the earliest stage is to give the best chance of an effective assessment and to minimise the chances of requiring a repeat visit.

The POA Team Leader should arrange for a debrief with the POA Holder personnel on a daily basis and at the end of the witness assessment.

- 5.8 As Competent Authority for production, the UK CAA reserves the right under 21A.157 to undertake direct assessment of any part of the POA Holder's quality system, including at suppliers and subcontractors. This is generally undertaken in response to non-compliances identified as part of routine Part 21 oversight, or where concerns have been raised regarding product conformity as a result of reports received or occurrences in service. Where such a visit is considered necessary, then it will be planned to address the Part 21 elements listed in 5.5 above and the agenda communicated to the POA Holder concerned. Such visits will normally be accompanied by representatives of the POA Holder while the CAA staff are on-site at the subcontractor. Again, any non-compliances identified as a result of such visits are to be addressed to the POA Holder for action.

6 Control of Vendors

6.1 Part 21A.139 (b) 1 requires a POA Holder's quality system to contain provisions for verification that incoming products, parts and materials are as specified in the applicable design data. This section defines CAA expectations in this area, drawing on lessons from recent experiences regarding production non-compliances of supplied items.

6.2 Where a purchased material / chemical has a direct effect on the function of a product, part or appliance related to airworthiness or safety, then the material / chemical should be subject to periodic evaluation by the POA by means of testing independent to that provided by the supplier.

Where the POA Holder does not have the capability to carry out such tests, then the analysis should be carried out by a laboratory which can provide traceability of the test and the calibration of the test equipment to appropriate controlling international standards.

The validation period should be established by the POA Holder based on the criticality of the purchased material/chemical to airworthiness and the confidence in the performance and reliability of the supplier on the basis of previous supplier audits, vendor rating system if used and the results of previous testing.

6.3 Examples are provided for assistance as follows:

- Extinguisher Gases – chemical composition;
- Structural Raw Materials and Fasteners – composition and hardness;
- Structural Adhesives* – composition and curing characteristics;
- Weld Consumables * – composition;
- Cabin Interior Materials – heat and smoke release.

* In these cases validation may be carried out at the production stage by means of test pieces etc.

7 Other Party Supplier Control

7.1 EASA Executive Decision 2010/016/R dated December 2010 introduced the concept of Other Party Supplier Control into Part 21. As a result GM No.2 to 21A.139(a) was amended to state "elements of the quality system for the control of suppliers may be performed by other parties provided that the conditions of AMC No.1 or No.2 to 21A.139(b)(1)(ii) are met.

7.2 AMC No. 1 – Shared Second Party Schemes

7.2.1 In order to reduce the overall subcontractor/supplier surveillance burden, POA Holders may wish to enter into arrangements for pooling of audit expertise and results such that the audit performance at a particular subcontractor/supplier may be used by more than one organisation. These generally fall into two categories:

- a) Arrangements between POA Holders who are members of the same corporate group sharing results using an internal quality system common between the various sites;
- b) Arrangements with organisations contracted directly by the POA Holder to conduct audit tasks that would normally be carried out by POA Holder personnel.

7.2.2 Both of these arrangements are acceptable, provided the conditions of AMC No. 1 are met including:

- a) Use of the arrangement has been agreed by the POA Team Leader following an application for a Significant Change (EASA Form 51) by the POA Holder and investigation by the CAA, following which the use of the arrangement can be added to the Exposition;
- b) The POA Organisation can demonstrate that it is an active member of the second party arrangement, i.e. that it participates in audits and has full access to audit planning, checksheets and results and uses this information as part of their quality management system assessment;
- c) In order to take credit for product auditing, the POA Organisation ensures that elements of their product are selected as part of the audit sample by the shared second party.

Where the shared second party scheme only addresses the Quality System requirements, the POA Holder remains responsible for the product audit element of surveillance and will still need to demonstrate how these are addressed at the supplier/subcontractor.

7.3 **AMC No. 2 – Third Party Schemes**

7.3.1 The EASA decision allows a POA to apply to the local Competent Authority for permission to use independent third party certification organisations (such as the Industry Controlled Other Party Scheme (ICOP) sector scheme system operated by the International Aerospace Quality Group (IAQG) or the NADCAP special process audits conducted by the Performance Review Institute (PRI)).

7.3.2 Both of these arrangements are acceptable, provided the conditions of AMC No. 2 are met including:

- a) use of the arrangement has been agreed by the POA Team Leader following an application for a Significant Change (EASA Form 51) by the POA Holder and investigation by the CAA, following which the use of the arrangement can be added to the Exposition;
- b) the POA Organisation can demonstrate that it is an active member of the arrangement, i.e. that it participates in audits and has full access to audit planning, checksheets and results and uses this information as part of their quality management system assessment. The POA Holder should review these procedures periodically and revise them as required to ensure that they remain up to date and representative of the requirements of Part 21;
- c) in order to take credit for product auditing, the POA Organisation ensures that elements of their product are selected as part of the audit sample by the shared second party;
- d) verification that the other party has access to applicable proprietary data to be able to undertake an effective surveillance of the supplier.

From the above, it will be seen that a POA Holder cannot state that it does not intend to review a particular supplier simply on the basis that it holds other party approval unless the POA Holder is part of the other party system.

Where the other party scheme only addresses the Quality System requirements, the POA Holder remains responsible for the product audit element of surveillance and will still need to demonstrate how these are addressed at the supplier / subcontractor.

INTENTIONALLY LEFT BLANK

Chapter D Engineering Practices and Processes

Leaflet D-10 Engineering Drawings

1 Introduction

The purpose of an engineering drawing is to record and convey the designer's requirements. The drawing must therefore, include sufficient information to enable production planning, manufacture, assembly, testing and inspection of the particular component or assembly to be carried out. So that there can be no misinterpretation of drawings, it is essential that both the person preparing the drawing and the person using the drawing should have a knowledge of the terms, symbols, abbreviations, and methods of presentation. This Leaflet gives general guidance on the various aspects of engineering drawings and should be considered in conjunction with any special methods used by the design office responsible for a particular drawing. This Leaflet is not intended as a standard for drawing offices, but should be regarded as a general guide to drawing procedures and interpretation.

NOTE: This Leaflet deals with general engineering drawing procedures, and does not include information on specialised subjects, such as electrical or electronic drawing practice, computer produced lofting, or numerically controlled tapes.

- 1.1 Drawing practice in the United Kingdom generally conforms to British Standard BS 8888. Design organisations amend the drawing systems to suit their own particular requirements, and generally produce their own Drawing Office Standards.
- 1.2 For current projects the International Organisation for Standardisation (ISO) system for dimensioning and tolerancing of drawings is used, but, at the present time, Imperial units, Metric units, terms, and tolerances, may be found on many drawings.
- 1.3 The abbreviations listed in Table 3 and the conventional representations of some standard features shown in Figures 10 and 15 will be found on most drawings. The terms and symbols used for tolerances in accordance with ISO recommendations, are shown in Table 5.

2 The Authority of the Drawing

Civil aircraft manufactured in the United Kingdom are manufactured from parts and components which have been manufactured to approved drawings. Design drawings and associated documents are normally produced by an organisation which has been approved by EASA or the Civil Aviation Authority, in accordance with European Union Commission Regulation 1702/2003 or British Civil Airworthiness Requirements (BCAR), as appropriate.

- 2.1 The requirements prescribe that all calculations on which the airworthiness of an aircraft depends, must be independently checked. Thus the design drawing itself is subject to a system of inspection, as are the parts produced to its requirements.
- 2.2 Drawings are used by Purchasing Departments, Production Engineers, Planners, Inspectors, and personnel engaged on the manufacture and assembly of components. A drawing must therefore, contain all the necessary dimensions, limits of accuracy, classes of fit, material specifications and any other information likely to

be required by any of the departments concerned, so that the user can carry out their respective responsibilities without reference back to the Design Department.

- 2.3 Any deviation from the approved drawings or associated documents during manufacture, must be approved by EASA or the CAA, as appropriate. During overhaul, modification, maintenance and repair, the Approved Organisation, or the appropriately licensed engineer, must ensure that all replacement parts, or repairs carried out, are in accordance with the approved drawings and associated documents.

3 Types of Drawings

Four types of drawings are recommended; single-part (unique parts or assemblies), collective (parts or assemblies of essentially similar shape, but of different dimensions), combined (a complete assembly including all individual parts on a single drawing), and constructional (an assembly drawing with sufficient dimensional and other information to describe the component parts of a manufacture). A complete set of drawings for an aircraft and any documents or specifications referenced on the drawings, present a complete record of the information required to manufacture and assemble that aircraft. They also form part of the inspection records. The manner in which a set of aircraft drawings is arranged, enables any particular component, dimension, procedure or operation, to be traced.

- 3.1 A main 'general arrangement' drawing of the aircraft and 'general arrangement' drawings of the main assemblies and systems are provided. These drawings usually contain overall profile particulars only, with locations and references of the associated main assembly and installation drawings; they also provide a guide to the identification of drawing groups used by the particular design organisation.
- 3.2 Main assembly drawings may also contain profile particulars only, but will include the information required for the assembly of individual parts of sub-assemblies. The sequence of assembly is given where appropriate, but the information contained in single part or sub-assembly drawings, is not repeated. Parts as such are referenced, but in the case of sub-assemblies, only the sub-assembly will be referenced and not its individual parts.
- 3.3 Installation drawings are issued to clarify the details of external dimensions and attitudes of components, locations, adjustments, clearances, settings, connections, adaptors, and locking methods between components and assemblies.
- 3.4 Sub-assembly drawings are issued to convey specific information on the assembly of component parts. When the method of assembly entails welding, or a similar process, the drawing will include details of any heat treatment or anti-corrosive treatment that may be necessary. Sub-assembly drawings are sometimes issued in connection with spares provisioning and also in cases where assembly would be difficult without special tools, jigs or techniques.
- 3.5 Drawings of individual parts contain all the information necessary to enable the parts to be manufactured to design requirements. The material specification, dimensions and tolerances, machining details and surface finish, and any treatment required, will all be specified on the drawings.

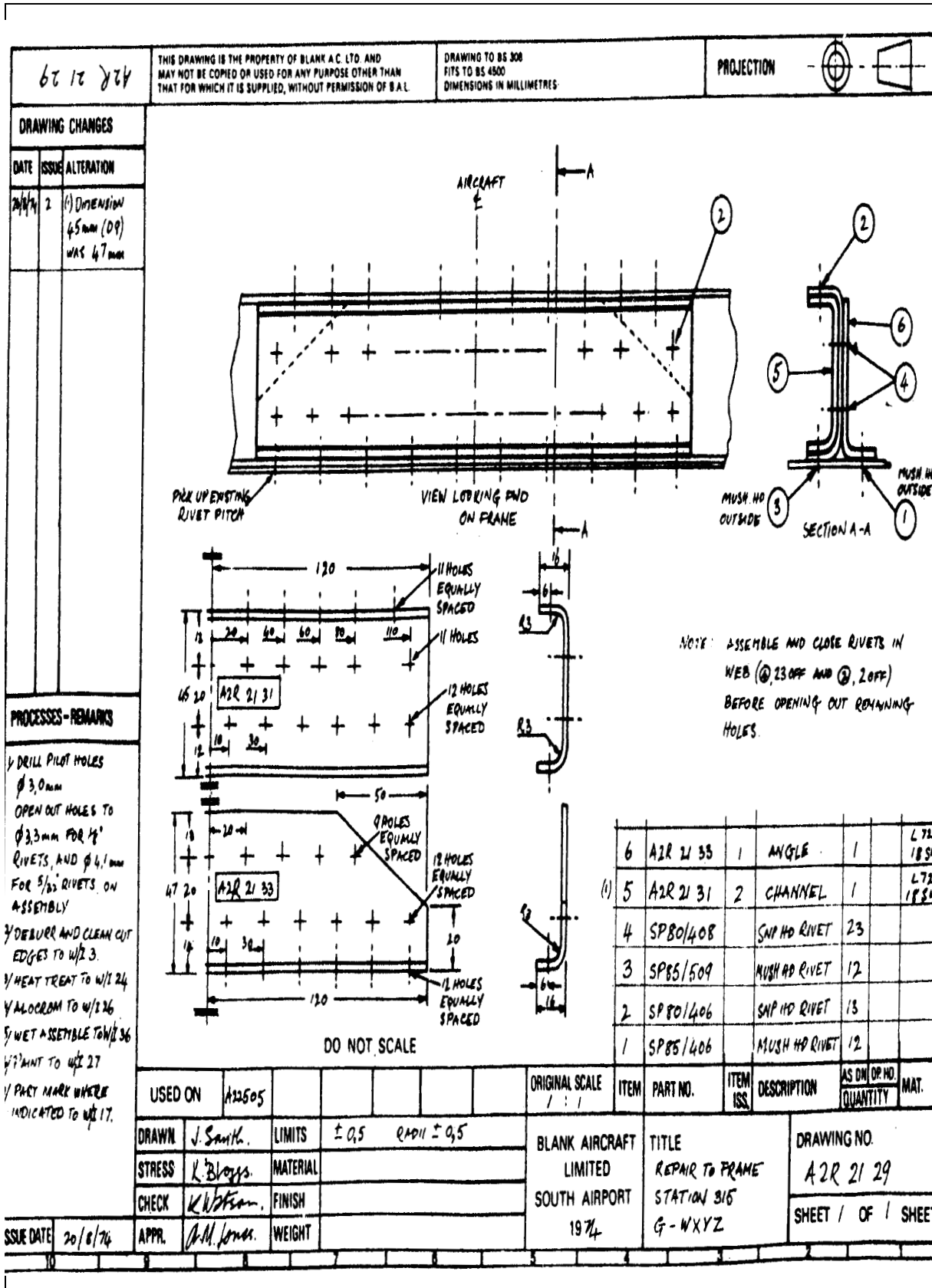

Figure 1 Typical Engineering Drawing

4 Drawing Systems

Section A of BCAR, prescribes that each drawing must bear a descriptive title, drawing number, issue number and the date of issue. It also prescribes that all alterations to drawings shall be made in accordance with a drawing amendment system which will ensure amendment to design records. If an alteration is made, a new issue number and date must be allocated to the drawing. To comply with the requirements, procedures must be introduced to progressively amend the total definition of the product in terms of its associated list of drawings at specific issues. Each particular variant of a product and its state of modification, must be identifiable in relation to the appropriate list of drawings. The following paragraphs amplify these procedures and explain the purposes of various parts of a drawing, together with the systems used and the methods of presentation. A typical drawing which illustrates many of the features with which this Leaflet is concerned, is shown in Figure 1.

4.1 The Drawing Number

No two drawings should bear identical numbers and a design office should maintain a register of all drawings issued. The drawing number has three features, the project identity (A2 in Figure 1), the group breakdown (21 in Figure 1), and an individual register number (29 in Figure 1). In Figure 1, A2 indicates the aircraft type, R indicates a repair, 21 indicates the front fuselage, and 29 indicates the register number in this group of drawings. Except for repair drawings, the drawing number is also generally the part number of the item.

4.1.1 Handed Parts

Drawings of handed parts usually have the left hand (port), upper, inner, or forward part drawn, this item taking the odd number and the opposite hand the consecutive even number. Parts which are not handed have an odd drawing number. The drawing sheet bears the legend 'AS DRAWN' and 'OPP HAND' in the item quantity column. Where necessary the handed condition is indicated by a local scrap view or annotation.

4.1.2 Sheet Numbers

Where a complete drawing cannot be contained on a single sheet, successive sheets are used. The first sheet is identified as 'SHEET 1 of X SHEETS', as applicable and subsequent sheets by the appropriate sheet number. Where a schedule of parts applicable to all sheets is required, it appears on Sheet 1.

4.2 Drawing Changes

Any change to a design drawing, other than the correction of minor clerical errors, must be accompanied by a new issue number and date. New parts added to the drawing, or 'drawn on' parts affected by the change, take the new issue number, and parts which are not affected retain the original issue number. In all cases where interchangeability is affected, a new drawing number and part number are allocated.

4.2.1 Details of the drawing changes are recorded in the appropriate column on the drawing, or recorded separately on an 'Alteration Sheet', which is referenced on the drawing. Changes are related to the change number quoted in the change of issue columns on the drawing and the marginal grid reference is given to identify the altered features.

4.2.2 The issue 'number' may sometimes be represented by a letter. Some organisations use alphabetical issues for prototype aircraft drawings and numerical issues for production aircraft drawings; thus all drawings of a prototype aircraft become 'Issue 1' when production commences.

- 4.2.3 An alteration to a single part drawing may also result in changes to associated drawings; in addition, it may be necessary to halt manufacture or assembly of the product. The drawing office system usually makes provision for the proper recording of drawing changes, by publishing, concurrently with the re-issued drawing, an instruction detailing the effects these will have on other drawings, on work-in-progress and on existing stock. As a further safeguard, some organisations publish Drawing Master Reference Lists, which give details of the current issues of all drawings which are associated with a particular component or assembly.

4.3 **Part Referencing**

Every item called up on a drawing is given an item number, which is shown in a 'balloon' on the face of the drawing, as illustrated in Figure 1. No other information is given in or adjacent to the balloon, with the exception of information necessary for manufacture or assembly, such as 'equally spaced', 'snap head inside', or the symbol 'ND', which indicates that no separate drawing exists for the part.

- 4.3.1 A schedule of parts is usually given in the manner shown in Figure 1, or on a separate sheet of the drawing (see paragraph 4.1.2).
- 4.3.2 As an alternative to the system described above, grid references may be given in the list of parts; in such instances the actual part numbers appear in the balloons. Where a part occurs a number of times on a drawing, e.g. as may be the case with rivets, bolts, etc., it may be impractical to list all grid references, in which case this column is left blank.
- 4.3.3 In instances where ND parts are shown as items on a drawing, the part number of such items may be that drawing number, followed by the drawing item number. Alternatively the part may be given its own part number, but will be identified as an ND part, e.g. 'A1 31 101 ND'. The information required for the manufacture of an ND part is contained in the description and material columns of the drawing, but reference may also be made to other drawings, where necessary.
- 4.3.4 Materials such as locking wire and shimming, which are available in rolls and sheets, will be detailed by specification number in the 'Part No' column, and the quantity will be entered as 'As Required', or 'A/R'. Standard parts to BS and SBAC Specifications will be detailed by the appropriate part numbers, but will not be drawn separately.

4.4 **Drawing Queries**

Drawing queries may arise through mistakes in draftsmanship, through ambiguity or through inability to purchase, manufacture, or assemble the items as drawn. Design Office procedures must be introduced which cater both for raising queries, and for providing satisfactory answers to those queries.

- 4.4.1 Drawing queries are usually raised on a Drawing Query Form, which is passed to the Design Office for action. The answer to the query may be an immediate provisional one, detailed on the query form; a temporary, fully approved answer, issued by means of a Drawing Office Instruction, and having the same authority as the drawing to which it refers; or a permanent answer provided by means of a new or re-issued drawing.
- 4.4.2 Drawing Query Forms and Drawing Office Instructions should be suitably identified, and should be referenced on the amended drawing. The effects on other drawings, on existing stock, and on work-in-progress, should be included in the answer to the query.

- 4.4.3 The number of Drawing Query Forms or Drawing Office Instructions permitted on a drawing should be limited, and a new or re-issued drawing should be completed as soon as possible.

5 Interpretation of Drawings

The following paragraphs indicate some of the general drawing practices used on aircraft drawings. These practices are in accordance with the recommendations contained in BS 8888 and associated British Standards, but many drawings will have been issued to previous British or foreign standards, and some degree of interpretation may be necessary. In cases of doubt the Drawing Office Handbook, or similar publication issued by the relevant Design Organisation should be consulted.







5.1 Scale

Drawings are normally drawn to a uniform scale and are normally shown in the 'ORIGINAL SCALE' box on the drawing in the form of a ratio, e.g. 1:2 (i.e. half size). Where details or views are drawn to a different scale, this should be clearly stated on the drawing. Aircraft drawings are often full size, i.e. 1:1, but no drawing should be measured to obtain a particular dimension which is not shown; the omission should be referred to the Design Office. On earlier drawings the scale may be represented by a fraction, e.g. $\frac{1}{4}$ which is 1:4.

5.2 Lines

The types and thicknesses of lines recommended in BS 128 are shown in Table 1. Drawings are often completed in pencil, however, line thickness may in practice vary considerably, especially after the drawing is reproduced.

Table 1 Types of Lines

Example	Description	Width (mm)	Application
	Continuous (thick)	0.7	Visible outline and edges.
	Continuous (thin)	0.3	Fictitious outlines and edges, dimensions and leader lines, hatching, outlines of adjacent parts and revolved sections.
	Continuous irregular (thin)	0.3	Limits of partial views or sections when the line is not on axis.
	Short dashes (thin)	0.3	Hidden outlines and edges.
	Chain (thin)	0.3	Centre lines and extreme positions moveable parts.
	Chain (thick at ends and changes of direction, thin elsewhere).	0.7 0.3	Cutting planes.
	Chain (thick)	0.7	Indicates surfaces which have to meet special requirements.

5.3 Projections

The majority of drawings produced for aircraft purposes show the parts in third angle orthographic projection (paragraph 5.3.1), but a number of older drawings may have been produced in first angle orthographic projection (paragraph 5.3.2). Both systems show objects as they actually are, both in size (unless for convenience the drawing is scaled up or down) and shape, when viewed in the vertical and horizontal planes. The projection used for a drawing must be clearly stated, and the appropriate international projection symbol must be placed in a prominent position on the drawing. Any views not complying with the projection stipulated, e.g. a view showing the true shape of an inclined face, are generally marked with an arrow, and suitably annotated.

5.3.1 Third Angle Projection

The principle of third angle projection is shown in Figure 2. Each view represents the side of the object nearest to it in the adjacent view.

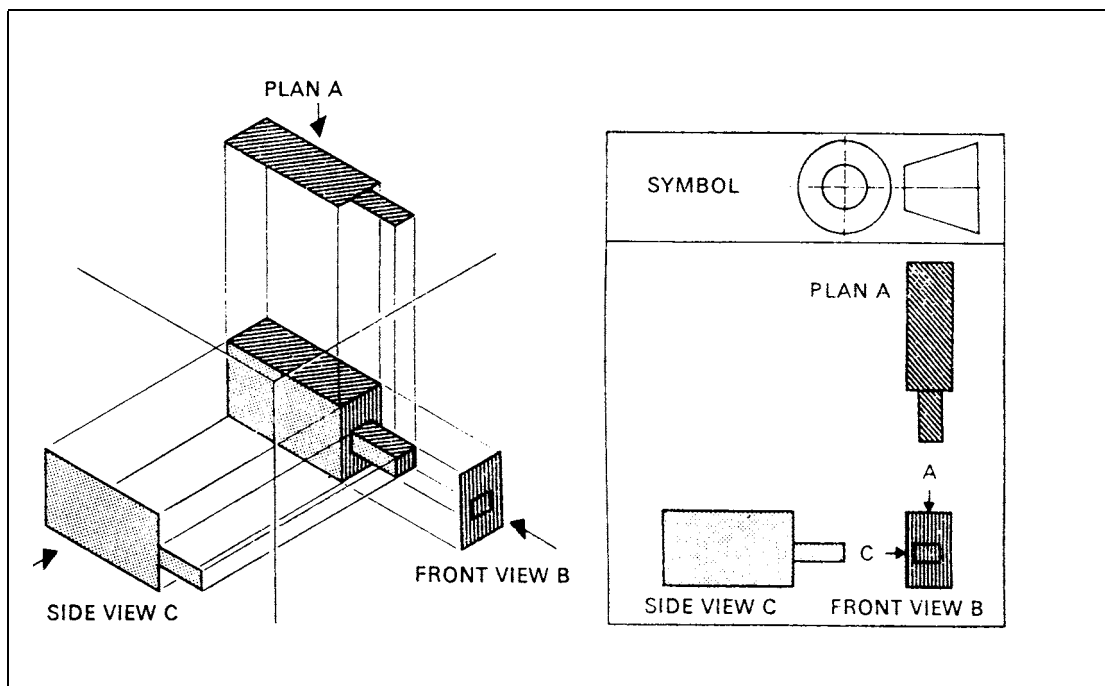

Figure 2 Third-angle Projection

5.3.2 First Angle Projection

The principle of first angle projection is shown in Figure 3. Each view represents the side of the object remote from it in the adjacent view.

5.3.3 Isometric Projections

These are pictorial views of an object, which are drawn with the three axes inclined, usually at an angle of 30°, to the plane of projection. The central drawing in Figure 2 and in Figure 3, is an isometric projection. Isometric views are sometimes used in drawings to indicate the position that the component occupies in the aircraft, or as a guide to understanding a complicated drawing.

5.4 Views

In general, all principal elevations are drawn looking at the left side of the aircraft, and the left hand item of handed parts is drawn. Other views are clearly annotated, e.g. 'view looking forward on frame'. The number of views shown on a drawing will

depend on the complexity of the part, although two views may often be sufficient. In some cases the three main views (Figures 2 and 3) may be insufficient to clarify all the details necessary, and a number of sectional or auxiliary views may be necessary.

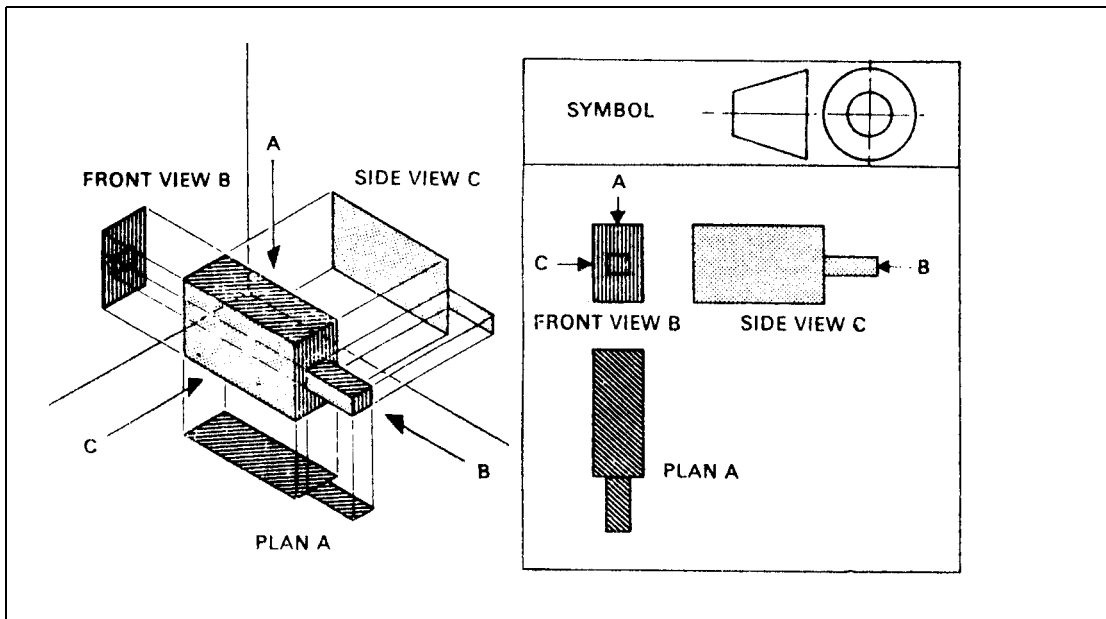

Figure 3 First-angle Projection

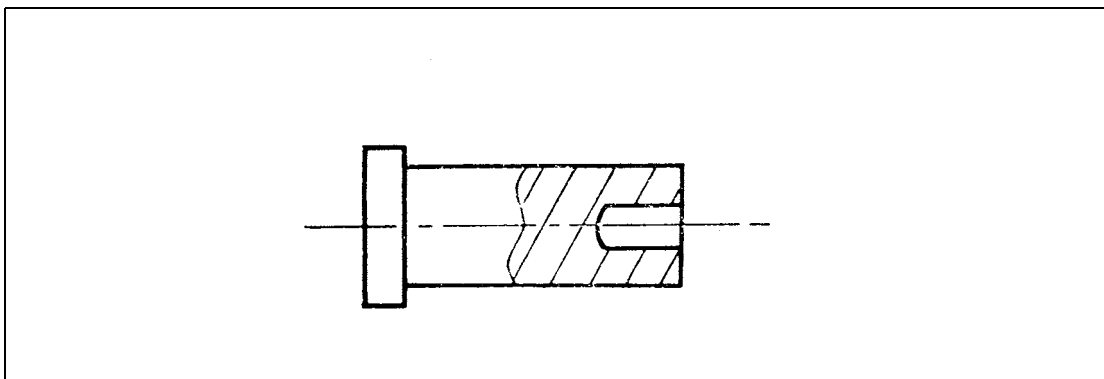

Figure 4 Part Section

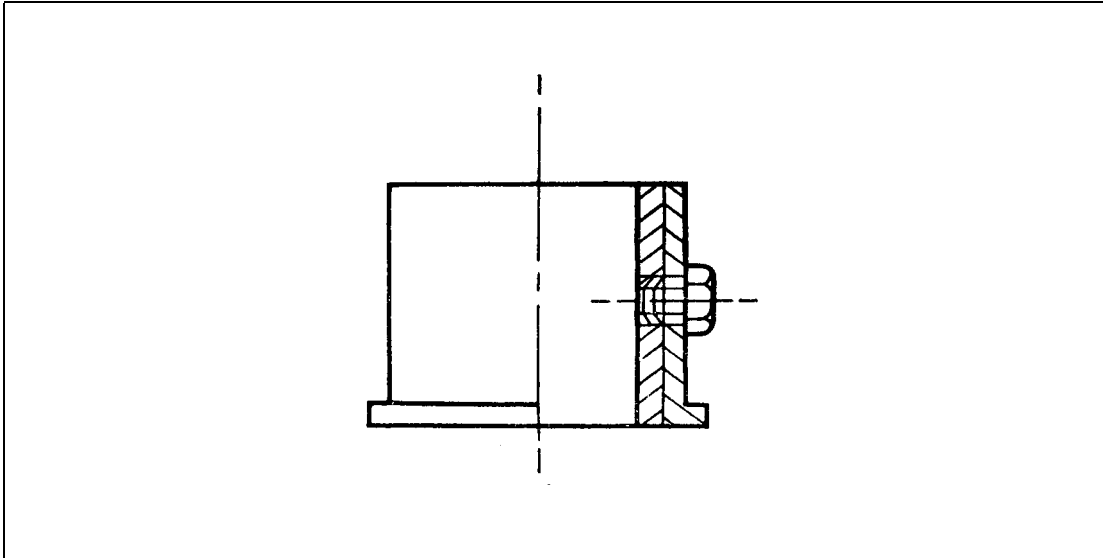

Figure 5 Half Section

5.4.1 Sectional Views

A sectional view may show a plan or elevation in complete section, the plane of the section being along one of the main centre lines. Where full sectioning is considered unnecessary, a part or half section may be used, and staggered sections are often used to illustrate particular features. Typical sectional views are illustrated in Figures 4, 5 and 6.

- a) Hatching lines are normally used to indicate the exposed section, but these may be omitted if the drawing is clearly understandable without them. Hatching lines are usually drawn at 45° to the axis of the section, and adjacent parts are hatched in different directions.
- b) Bolts, rivets, shafts, ribs, and similar features are not normally shown in longitudinal section.

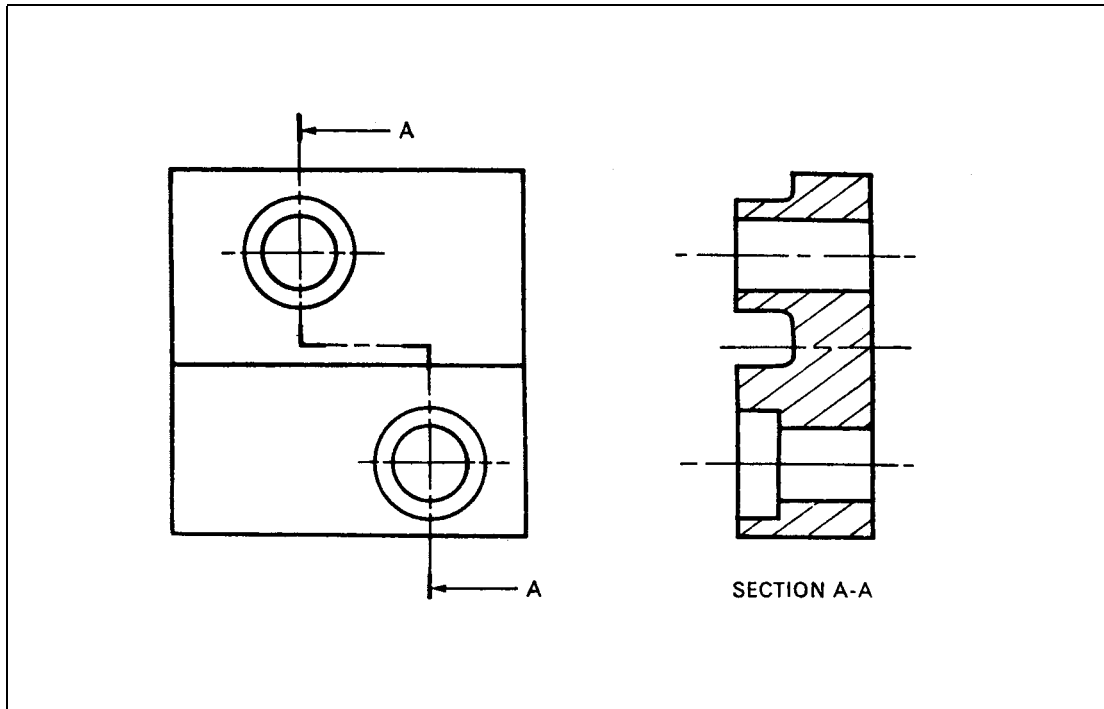

Figure 6 Staggered Section

5.4.2 Auxiliary Views

Neither a plan nor an elevation will show the true shape of a surface inclined to the plane of projection. The true shape of such a surface is shown by means of an auxiliary view, the auxiliary plane being imagined as being parallel to the surface being illustrated, as shown in Figure 7.

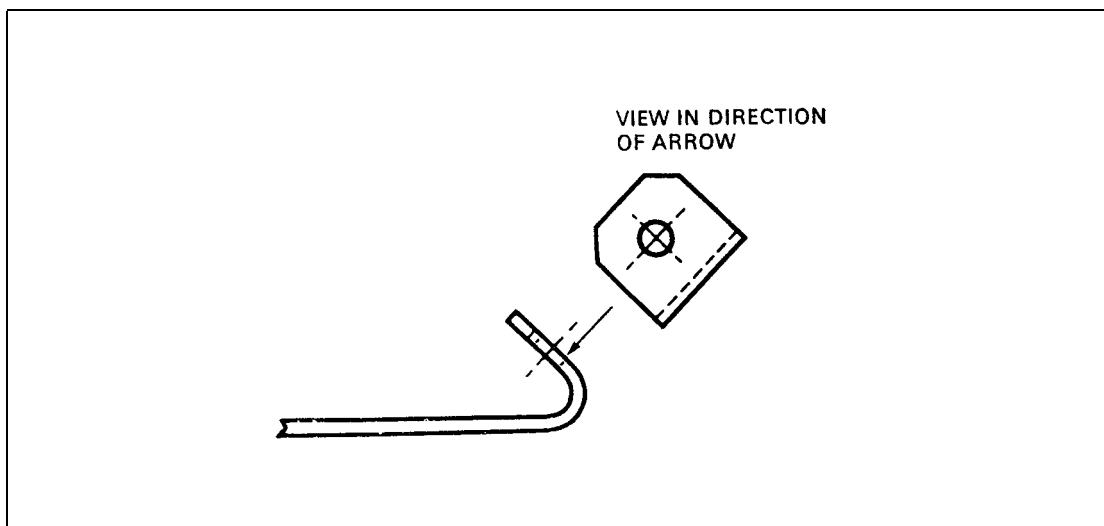

Figure 7 Auxiliary View

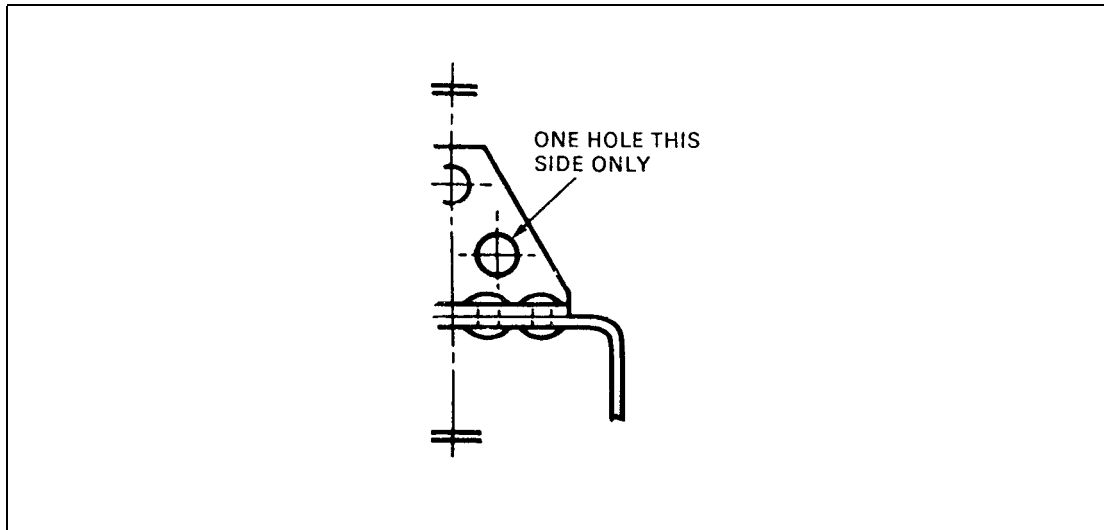

Figure 8 Symmetrical Parts

5.4.3 Symmetrical Parts

Parts which are symmetrical, or nearly so, may not be fully drawn. Sufficient information is normally provided by drawing one half or segment of the part; any asymmetry being identified by a note. Figure 8 shows a symmetrical part, and illustrates the method of defining the line of symmetry.

5.4.4 Repetitive Information

Where several features are repeated in a regular pattern, such as rivets, bolts, or slots, only the number required to establish the pattern may be shown, by marking their centrelines. Any further information will be given in a note. Figure 9 shows a typical skin joint which could be drawn in this manner.

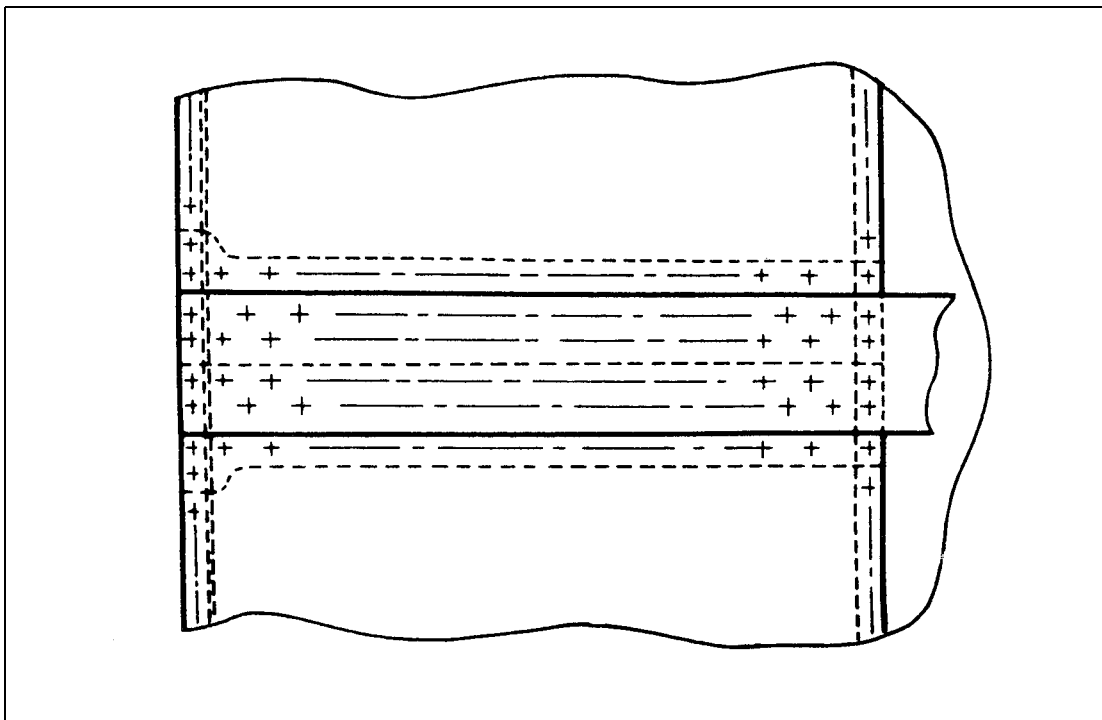

Figure 9 Repetitive Features

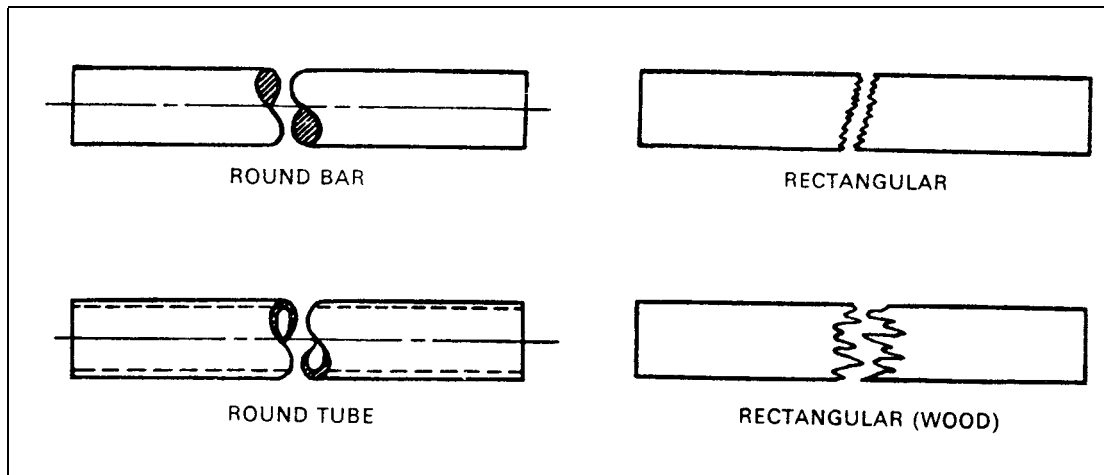

Figure 10 Break Lines

5.4.5 Break Lines

Break lines are used where it would be inconvenient (because of limited space) to draw long lengths of standard section. The types of break lines used for various components are shown in Figure 10.

5.5 Dimensioning

All dimensions necessary for the manufacture of the part or assembly are given on the drawing; it should not be necessary to deduce any dimension from other dimensions. To avoid confusion, dimensions are normally given once only. The units of measurement used are usually stated on the drawing, to avoid repetition, but any dimension to which this general statement does not apply will be suitably annotated. Dimensions are placed so that they may be read from the bottom or right hand side of the drawing.

- 5.5.1 When dimensions are given from a common datum, one of the methods shown in Figure 11 is normally used. Chain dimensioning, i.e. dimensioning between adjacent holes, is not often used, since it allows a build up of tolerances, which may not be acceptable. An alternative method, used with riveted joints, is to locate the end holes and add a note such as '11 rivets equally spaced'; this method is useful on curved surfaces.

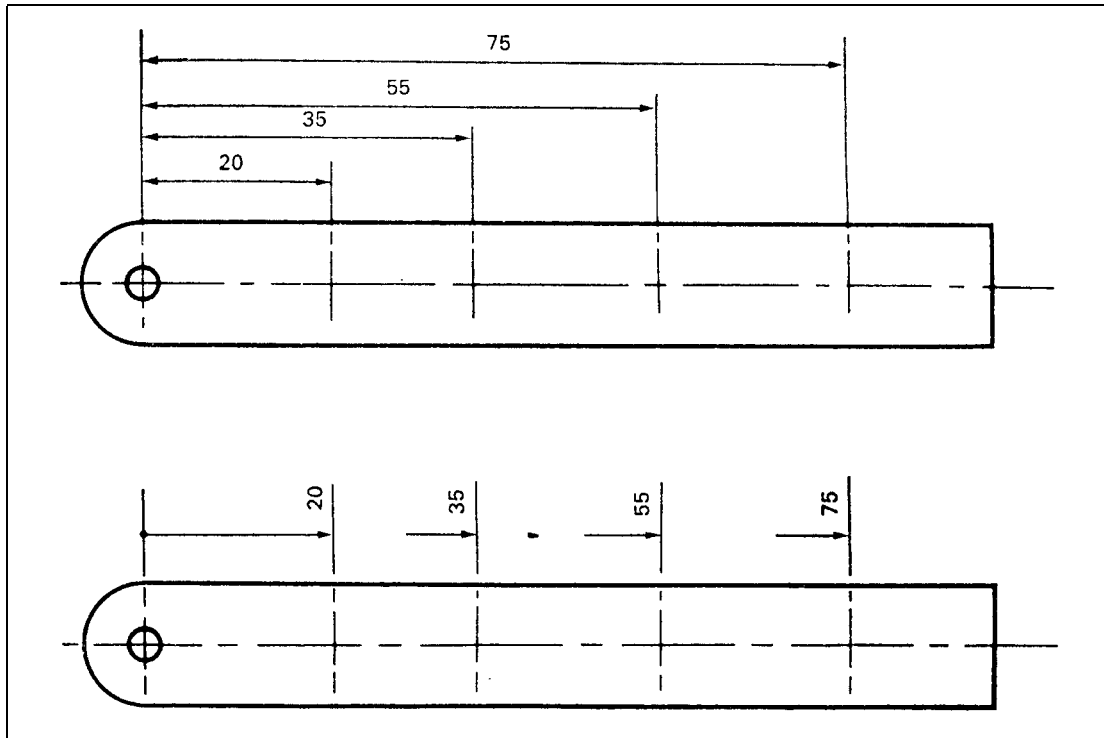

Figure 11 Dimensioning from a Common Datum

- 5.5.2 Machined components are usually measured by a system of functional and non-functional dimensions. The functional dimensions are those which directly affect the function of the component, e.g. the length of the plain portion of a shouldered bolt. A non-functional dimension would be the depth of the bolt head, and other dimensions chosen to suit production or inspection. Auxiliary dimensions may also be given, without tolerances, for information.

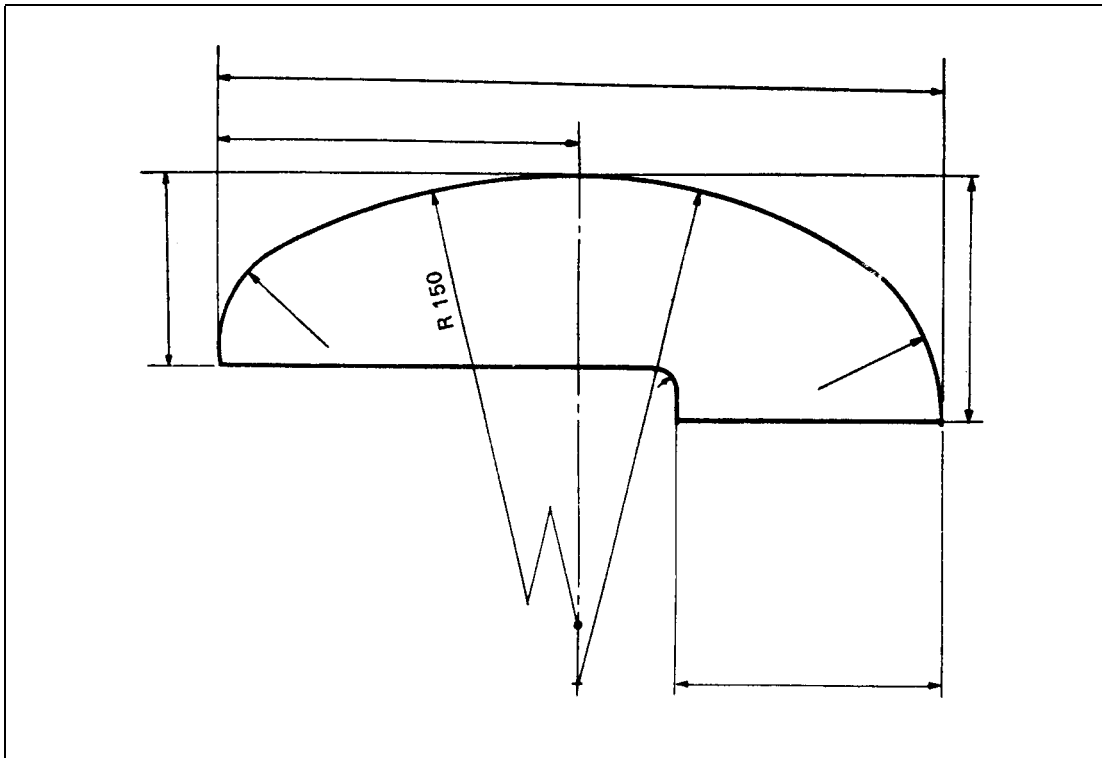

Figure 12 Dimensioning Profiles by Radii

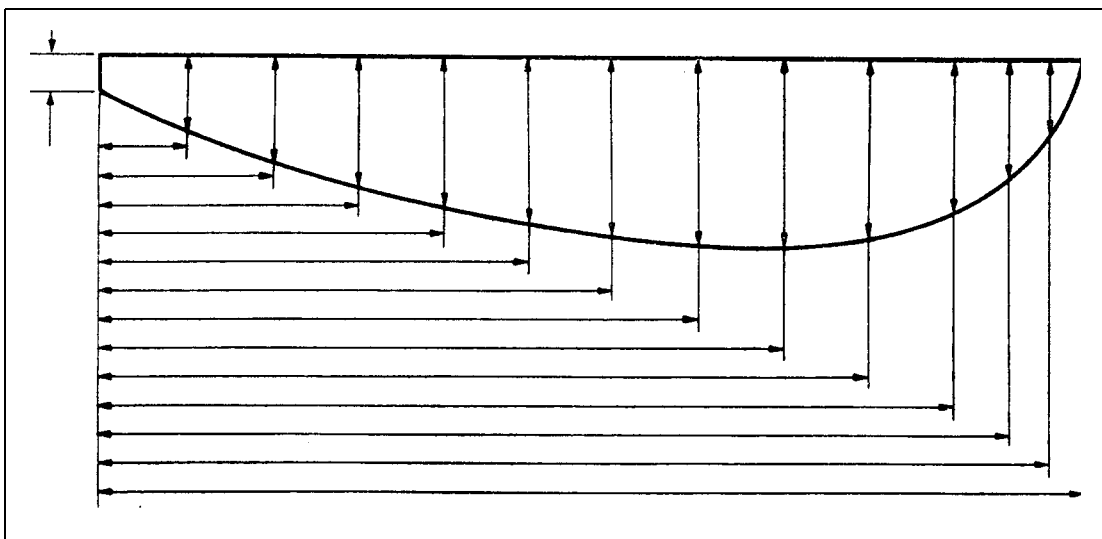

Figure 13 Dimensioning Profiles by Ordinates

5.5.3 Dimensioning of Curved Profiles

Items the profiles of which are curved, are where practicable, dimensioned by means of radii, as shown in Figure 12. Where a radius is very large, and the centre of the arc could not be shown on the drawing, the method shown for the R150 dimension in Figure 12 may be used; the portion of the radius which touches the arc being in line with the true centre. Where this method cannot be employed, a system of ordinates may be used, as shown in Figure 13. The radii method is usually preferred, since accurate arcs can be produced; whereas with the ordinate system, deviations from the required curve may occur as a result of connecting the plotted points.

5.6 **Dimensional and Angular Tolerances**

A general tolerance is usually given for all dimensions on a drawing and may be found in the appropriate box on the printed layout. Where the general tolerance is inadequate or restrictive, an individual tolerance may be given to a dimension.

5.6.1 Tolerances may be expressed by quoting the upper and lower limits, or by quoting the nominal dimension and the limits of tolerance above and below that dimension. Examples of both linear and angular tolerances are shown in Figure 14. Geometric tolerances are dealt with in 5.11.

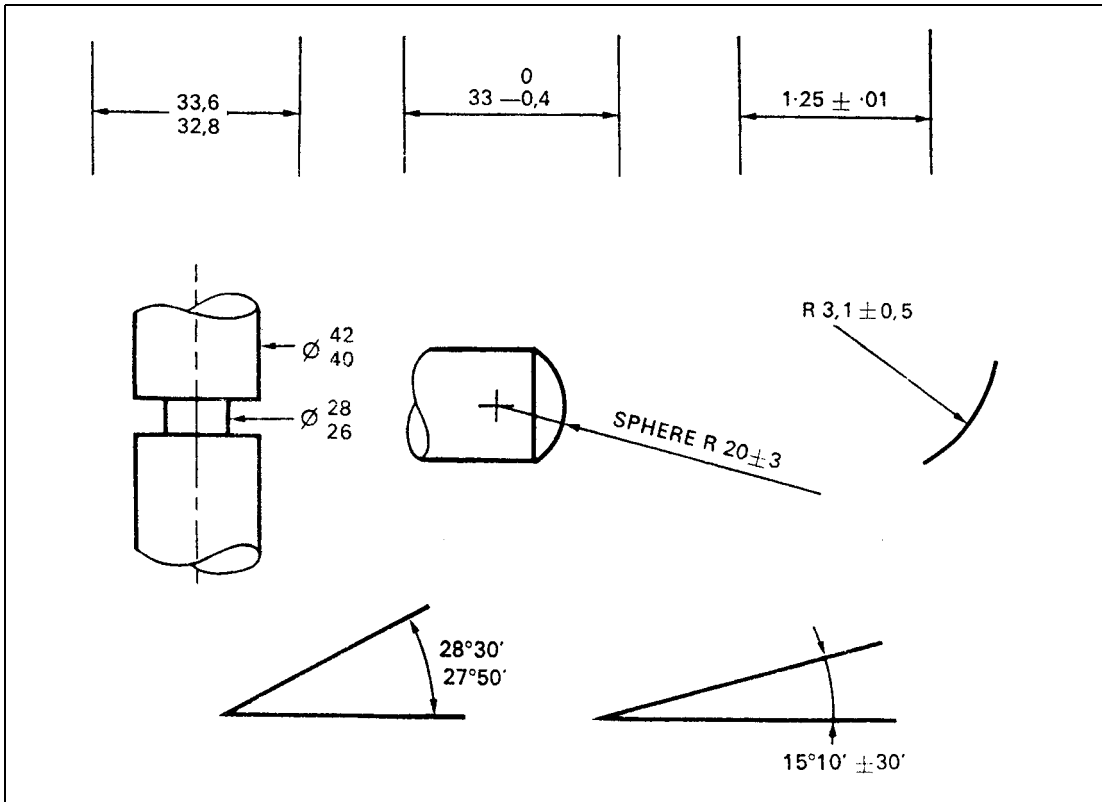

Figure 14 Dimensional Tolerances

5.7 **Machining and Surface Finish**

When a machining operation is required on a particular surface, the symbol is ∇ used, and is located normal to that surface. When the component is to be machined all over, the symbol ∇ ALL OVER is used, and, in some cases, the type of machining is indicated with a note such as ∇ LAP.

5.7.1 The machining symbol is also used to indicate the surface finish required; the maximum roughness figure being added to the symbol thus: ∇ 4. The surface finish quoted on a particular drawing depends on the system being used. The relationship between the various systems is included for reference in Table 2. Detailed information on the assessment of surface texture is provided in British Standard BS 1134 and specifications for roughness comparison specimens are contained in BS 2634.

Table 2 Surface Texture Equivalents

Nominal Values	micrometre	0.025	0.05	0.1	0.2	0.4	0.8	1.6	3.2	6.3	12.5	25	50
	microinch	1	2	4	8	16	32	63	125	250	500	1000	2000
Roughness Number		N1	N2	N3	N4	N5	N6	N7	N8	N9	N10	N11	N12

5.8 Abbreviations and Symbols

In order to save time and drawing space when compiling a drawing, a number of abbreviations and symbols are used. Table 3 lists the main abbreviations and symbols which will be found on both currently produced and older drawings.

5.9 Conventional Representations

Common features, which may appear several times on a drawing, are seldom drawn in full, since this would take up space and drawing time, unnecessarily. These features are shown by conventional representations, some examples of which are illustrated in Figure 15.

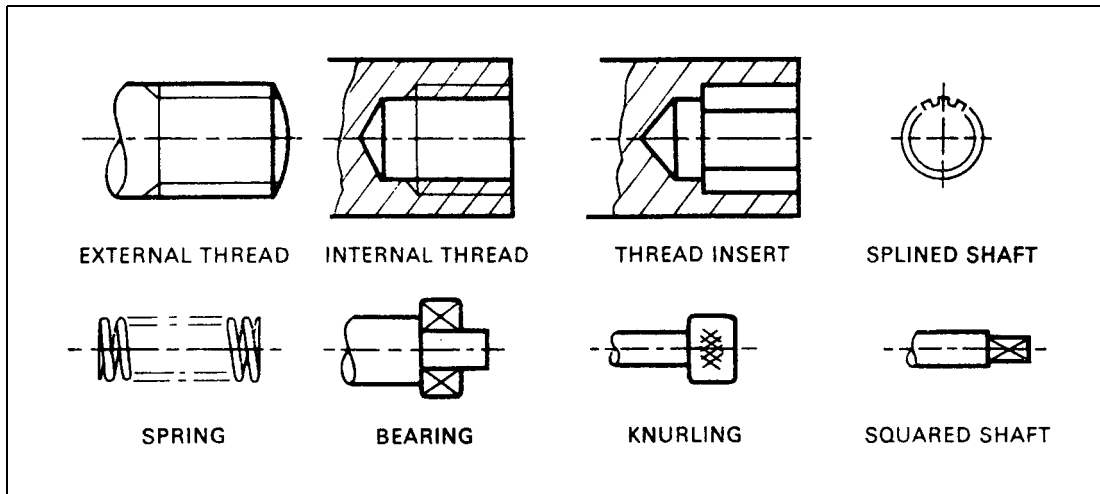

Figure 15 Conventional Representations



5.10 Process and Identification Markings

Drawings will often call for identification markings on parts and will indicate both the position of the markings and the method of application, e.g. rubber stamp. In addition, it is sometimes necessary to mark the component to show that a particular process has been carried out and this will also be specified on the drawing. Symbols are normally used for this purpose and some of the more common ones are shown in Table 4. Some Design Organisations may use different symbols or code letters, which should be obtained from the Drawing Office Handbook, or similar publication, produced by the organisation concerned.

5.11 Geometric Tolerances

It is sometimes necessary to place tolerances on both geometric features and dimensions, in order to adequately control the shape of a part. On older drawings this was done by annotating the feature to be toleranced, e.g. POSN TOL, and by adding notes to the drawing, in order to specify the tolerance and the method of checking. On newer drawings, the international system recommended in BS 8888 is used, and this method is outlined in the following paragraphs.

Table 3 Abbreviations and Symbols

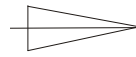
Term	Abbreviation	Term	Abbreviation
Across Flats	A/F	Pattern number	PATT NO
Assembly	ASSY	Pitch circle diameter	PCD
British Standard	BS	Pneumatic	PNEU
Centres	CRS	Pound (weight)	LB
Centre line	CL or 	Radius	RAD or R
Chamfered	CHAM	Reference	REF
Cheese Head	CH HD	Required	REQD
Counterbore	C'BORE	Revolutions per minute	RPM or REV/MIN
Countersunk	CSK	Right Hand	RH
Cylinder or cylindrical	CYL	Round head	RD HD
Degree (of angle)	°	Screw thread:	
Diameter - in a note	DIA	British Association	BA
- as dimension	∅	British Standard Fine	BSF
Figure	FIG	British Standard Pipe	BSP
Full indicated movement	FIM	British Standard	
Hardness - Brinell	HB	Whitworth	BSW
- Rockwell	HR	Unified Coarse	UNC
	(+scale letter)	Unified fine	UNF
- Vickers	HV	Unified special	UNS
Hexagon	HEX	Screwed	SCR
Hexagon head	HEX HD	Second (of angle)	"
Hydraulic	HYD	Sheet	SH
Inch	IN or "	Sketch	SK
Insulated	INSUL	Specification	SPEC
Internal diameter	I/D	Spherical diameter	SPHERE ∅
Left Hand	LH	Spherical radius	SPHERE R
Long	LG	Spotface	S'FACE
Machine	M/C	Square	SQ
Machined	M/CH	Square inch	SQ IN or IN ²
Material	MATL	Standard	STD
Maximum	MAX	Standard wire gauge	SWG
Max material condition	MMC or 	Taper	
Millimetre	MM	Threads per inch	TPI
Minimum	MIN	Undercut	U'CUT
Minute (of angle)		Volume	VOL
Not to scale	NTS	Weight	WT
Number	NO		
Outside diameter	O/D		

NOTE: Capital letters are normally used on a drawing, for clarity, but lower case letters may be used elsewhere as appropriate.

Table 4 Process and Treatment Symbols

Process or Treatment	Symbol	
Solution treated and not requiring precipitation	(N)	
Solution treated and requiring precipitation		(W)
Precipitation treatment	(P)	
Solution treated and precipitated		(WP)
Annealed	(A)	
Hardened and tempered		(HT)
Mechanical test.....	(M)	
Dye penetrant check		(PFD)
Ultra-sonic test.....	(UFD)	
Anodic flaw detected		(AFD)
Cleaned (pipes)	(AC ₁)	
Repaired and reconditioned		(R)
Normalised steel parts	(N)	
Proof loads		(PL)
Stress relieved	(SR)	
Pressure test.....		(PT)
X-ray flaw detection	(XR)	
Salvaged.....		(S)
Electro-magnetic flaw detection	(MFD)	
Welding.....		(WS)
Etch inspection of steel.....	(E)	

5.11.1 Information relating to a particular geometric tolerance is enclosed within a rectangular frame on the drawing, an arrow from the frame indicating the location of the feature to which the tolerance applies. If the tolerance is related to a particular datum, a leader line is drawn from the frame to the datum position, or the datum is referenced separately, and identified by a letter in the frame. Unless the datum is a dimension, it is defined by a solid equilateral triangle. Examples of the methods of indicating geometric tolerances are shown in Figure 16, and the symbols used to identify the characteristic to which the tolerance is applicable are listed in Table 5. Detail (f) in Figure 16 shows a completely dimensioned component.

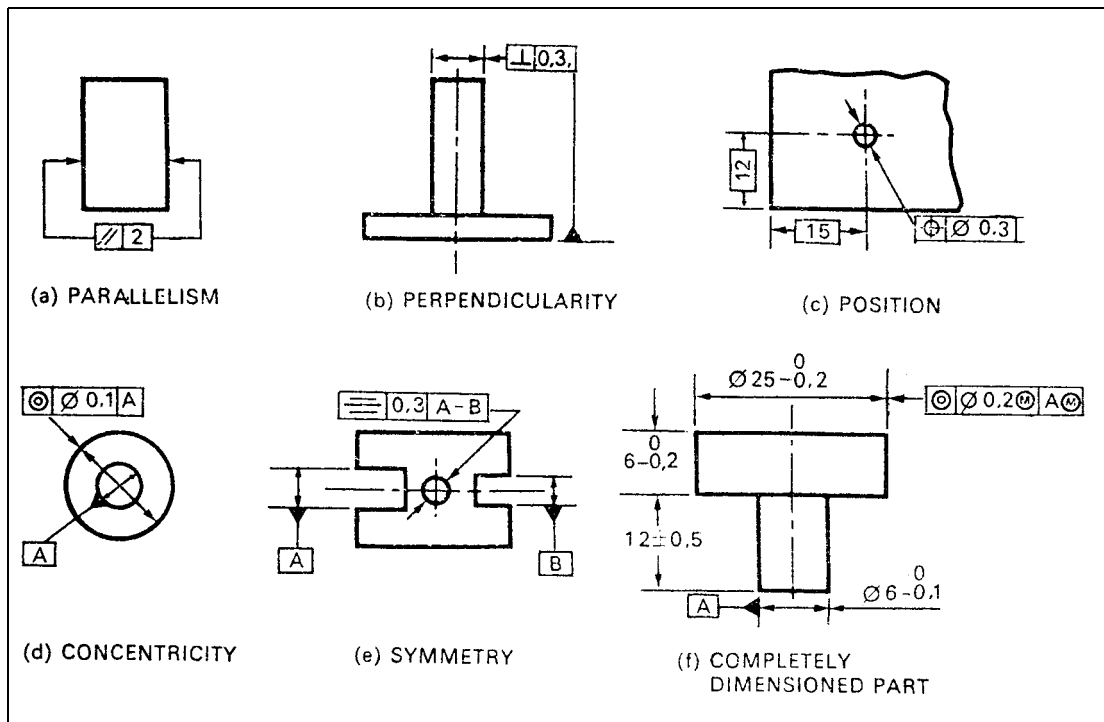

Figure 16 Geometric Tolerances

- 5.11.2 As a guide to the interpretation of a geometric tolerance, reference may be made to detail (e) of Figure 16. This indicates that a symmetry tolerance of 0.3 mm is required, with respect to datum features A and B. This tolerance indicates that the axis of the hole must be between two parallel planes, 0.3 mm apart, which are symmetrically disposed about the common median plane of the slots in the end of the part. The hole could also, if necessary, be marked to indicate a symmetry tolerance at 90° to the plane specified, and the tolerance for this could be different.
- 5.11.3 The symbol (M) in detail (f) of Figure 16, indicates that the tolerance applies only to the maximum material condition of the dimension or datum feature and may be greater at the actual finished size.

Table 5 Geometric Tolerance Symbols

Feature	Type of tolerance	Characteristic	Symbol			
Single	Form	Straightness				
		Flatness				
		Roundness				
		Cylindricity				
		Profile of a Line				
		Profile of a surface				
Related	Attitude	Parallelism				
		Squareness				
		Angularity				
Related	Location	Position				
		Concentricity				
		Symmetry				
Related	Composite	Run-out				
Maximum material condition						
Dimension which defines a true position						
Tolerance Frame						
Datum feature						
Symbol for characteristic to be tolerated			21,4	A		Used when tolerance applies to the MMC of the feature
	Used where tolerance is circular or cylindrical		Total tolerance			

Leaflet D-20 Measurement and Calibration Systems

1 Introduction

- 1.1 Requirements within the relevant airworthiness codes applicable to the United Kingdom civil aviation industry such as British Civil Airworthiness Requirements (BCARs), Joint Aviation Requirements (JARs), and Air Operators Certificates (arrangements for maintenance support) prescribe that, where necessary, tools, equipment and in particular test equipment (herein after called appliances) are calibrated to standards acceptable to the CAA.
- 1.2 This Leaflet gives guidance on the general aspects of establishing and maintaining an effective calibration system acceptable to the CAA. It takes into account factors such as the degree of accuracy required, frequency of use and reliability of the appliance. The key factor, however, is the need to establish confidence in the accuracy of the equipment when required for use. The required calibration frequency for any particular appliance is that which will ensure it is in compliance with the standards applicable to its intended use.
- 1.3 In all cases, standards used are predicated upon the need for ultimate traceability to one of the following:
- The standard specified by the appliance manufacturer/design organisation.
 - The appropriate national/international standard.

2 General

- 2.1 The appropriate standards are used to achieve consistency between measurements made in different locations possibly using alternative measuring techniques. Calibration of appliances is best achieved by operating a methodical system of control, traceable by an unbroken chain of comparisons through measurement standards of successively better accuracy up to the appropriate standard.
- 2.2 Where recommendations for calibration standards are not published or where the calibration or standards are not specified, calibration should be carried out in accordance with 'British Standard EN 30012–1 Quality Assurance Requirements for Measuring Equipment.'
- 2.3 As an alternative to operating an internal measurement and calibration system, an Approved Organisation/Licensed Engineer may enter into a sub-contracting arrangement to use the services of an appliance calibration service. This, however, does not absolve the user from implementing suitable controls and maintaining calibration records appropriate to paragraph three of this leaflet.
- 2.4 In all cases it is the responsibility of the user to satisfy himself that an unbroken traceability chain is in place. Organisations such as those holding suitable United Kingdom Accreditation Service (UKAS) accreditation may be considered to be acceptable to provide external calibration services.

3 Procedural Controls

- 3.1 Appliances requiring calibration are those items which are necessary to perform measurements or tests of an aircraft, system or component to defined limits, as specified in the Type Certificate holders technical documentation.
- 3.2 Procedures controlling inspection/servicing and, where appropriate, calibration of such items on a regular basis and to indicate to users that the item is within any inspection, service or calibration time-limit should be developed.
- 3.3 A programme should be developed to plan the periodic inspection, service or calibration within defined time limits to ensure appliances remain in calibration. The programme should consider staggering inspections, servicing or calibrations to ensure that the maximum number of appliances are available at all times. A register of such appliances is essential in order that control of the calibration system is achieved in a co-ordinated manner. Where the appliance holding does not provide a level of redundancy, contracted loan arrangements may be acceptable.
- 3.4 The intervals at which calibration is required to be conducted can vary with the nature of the appliance, the conditions under which it is used and the consequences of incorrect results. The inspection, service or calibration intervals should therefore be in accordance with the appliance supplier's instructions, except where the organisation can show that a different interval is warranted in a particular case. This would normally require a system of continuous analysis of calibration results to be established to support variations to manufacturers recommended intervals.
- 3.5 A clear system of labelling calibrated appliances is therefore necessary setting out when the next inspection, service or calibration is due and indicating the serviceability, particularly where it may not be obvious.
- 3.6 Any appliances whose serviceability is in doubt, should be removed from service and labelled accordingly. Such equipment shall not be returned to service until the reasons for the unserviceability have been eliminated and its continued calibration is re-validated. Where the results of calibration prior to adjustment or repair indicate that a risk of significant errors may have existed in any previous measurements made, the necessary corrective action should be taken.
- 3.7 Records shall be maintained in order that it can be demonstrated that the appliance is capable of functioning within the designated limits. The scope of records to be maintained is dependant on standards used and the nature of the appliance. The record system may also provide a valuable reference in cases of dispute, or warranty claims, but they are also used for assessing calibration drift and wear. Such data provides a basis for development of effective calibration intervals.

Calibration records or certificates should, as a minimum, contain the following information for each appliance calibrated:

- identification of equipment
- standard used
- results obtained
- uncertainty of measurement
- assigned calibration interval
- limits of permissible error
- the authority under which the release document was issued

- any limitation of use of the equipment
 - date on which each calibration was conducted.
- 3.8 Where calibration services are provided by outside Organisations, it is acceptable to the CAA for the accuracy of the item to be attested by a release document in the name of the company which records the information specified in paragraph 3.7.
- 3.9 Any measurement is affected to some degree by the environmental conditions under which it is carried out. Appliances need to be calibrated, transported and stored under conditions compatible with the type of equipment to ensure accuracy is not impaired.
- 3.10 To provide valid repeatable test results, the facilities used for calibration undertakings are expected to provide controlled environmental conditions to comply with the applicable standard or original appliance supplier's specification. It will therefore be necessary to control temperature, humidity, vibration, dust, cleanliness, electromagnetic interference, lighting and any other factors that may affect calibration results to predetermined standards. In cases where appliances cannot be placed in a controlled environment for calibration, compensation corrections should be applied to the calibration standard to provide the required level of accuracy.
- 3.11 Although not a substitute for regular calibration, confidence that an appliance continues to measure correctly can be obtained by the use of a checking measurement standard, applied by the user. This will demonstrate that, at the value or values checked and under the conditions of the check, the appliance is still functioning correctly. The checking standard itself, which usually has to be simple and robust, will need to be calibrated in order that the results obtained by its use can, with reliance, be attributed to the instrument and not to changes in the checking measurement standard.
- 3.12 Any calibration system adopted would need to comply with the minimum requirements of the airworthiness code to which it has been implemented. The continued effectiveness of the calibration system and associated procedures should be periodically and systematically reviewed by company quality systems.

INTENTIONALLY LEFT BLANK

Leaflet D-30 Clean Rooms

1 Introduction

The higher reliability requirements specified for aircraft system components and in particular, those associated with complex electronic, instrumentation and mechanical systems, necessitated the development of techniques for controlling contamination which in various forms is a common cause of component failure. It also became necessary to apply these techniques to selected areas of manufacturing and aircraft operating organisations in which the various processes of manufacture, overhaul and testing can be carried out under controlled environmental conditions. Such selected areas are referred to as Clean Rooms, the design and manufacture of which form part of an independent and highly specialised field of work to British Standard BS EN ISO 14644-2: 2000, 14644-4: 2001 and 14644-6: 2004.

- 1.1 The information given in this Leaflet is intended purely as a guide to the subject of Clean Rooms and is not intended to replace component manufacturer's clean room requirements where published. Subject headings are as follows:

Subject	Paragraph
Sources of Contamination	2
Control of Contamination	3
Size of Contaminants	4
Classification of Air Cleanliness	5
Classification of Clean Rooms	6
Environment and Comfort Control	7
Air Handling Systems	8
Layout of Clean Rooms	9
Manufacture of Clean Rooms	10
Clean Room Furnishings	11
Clean Room Garments	12
Clean Work Stations	13
Clean Room Operation	14
Maintenance of Clean Rooms	15

2 Sources of Contamination

Any substance that causes failure or malfunctioning of a component is a contaminant, the particles of which may take a variety of forms and stem from many sources.

2.1 **Air**

The air which continually surrounds the components may be considered as a contamination storehouse containing dirt and dust particles, organic and inorganic vapours.

2.2 **Manufacture**

Contaminants are produced during all manufacturing processes. Particles, such as swarf resulting from a machining operation, or particles forced into the surface of a component during a pressing or heating process, can be of such a nature that their effect can be immediate or delayed. Depending on the composition of the particle and component materials, the alloys or compounds formed by interaction can result in serious loss of a component's structural strength over a period governed by the rate of diffusion.

2.3 **Assembly**

During the assembly process the possibility of introducing contaminants is probably greatest because of exposure to the highest levels of contaminant sources. In the soldering process for example, the vapourisation of flux causes particles to escape into the surrounding air which, on cooling, condense as droplets on a nearby cold surface of the component. Depending on the location of the particles and the forces applied to them, they can act as a contaminant with an immediate or delayed effect.

2.3.1 The use of jointing adhesives can also produce contamination similar to that of a soldering process. In addition, vapours can be given off which can migrate to other parts of an assembly and act as a delayed-action contaminant.

2.3.2 Assembly of components using threaded joints can produce fibre-shaped fragments or flakes as a result of an effect similar to wire drawing. For extremely close fit or for balancing purposes, it may be necessary to fit individual parts of a component together by grinding, lapping or honing operations. In any such operation, contaminant particles can be dispersed in the atmosphere, suspended in fluids, adhere to the surfaces of component parts, or become embedded into the surfaces.

2.3.3 Assembly of components in jigs, or while being handled or supported by tools, may result in deformation of surfaces and production of contaminant particles. For example, if during tightening of a bolt, slippage of the spanner jaws occurs, particles are produced from the bolt head. Particles are also produced from the heads of bolts or screws and component surfaces during final tightening.

2.4 **Storage and Transit**

During the second period of assembled components and of associated independent parts, contamination can occur in several ways notwithstanding the use of protective coverings or containers. Particles from the air may be deposited as a result of gravitational settling and also as a result of electrostatic effects. Improperly cleaned containers or covers may transfer particles to components, in particular where padded containers and plastics containers are used. In the first case, the contours of the container may trap particles which are not released until the component causes deformation of the padding. In the second case, plastics containers may pick up particles from the air due to electrostatic charging and hold them until transferred to the packed component.

2.4.1 Containers which are not hermetically sealed are subject to a 'breathing' cycle as the temperature of the container varies. During the intake portion of the cycle, particles in the air surrounding the container may be drawn into a position where they can contaminate the component.

- 2.4.2 The movement of packed containers during transit is also a source of contamination since it may dislodge contaminant particles not previously cleaned off, or create new particles by abrasion.

2.5 **Component Cleaning Processes**

A cleaning process is actually a process of transforming contamination from a high level of concentration to a lower one; therefore, tolerance levels must be considered relative to the component's function and required operational accuracy.

- 2.5.1 The transfer of contaminant particles is dependent on the methods used in the cleaning process, i.e. whether wiping or polishing with an absorbent or collecting material (dry cleaning transfer) or cleaning by means of a liquid (wet cleaning transfer). Problems exist in each of these processes.

- 2.5.2 The ways in which dry cleaning can contaminate include the following:

- a) Removal of fibrous particles from the cleaning material.
- b) The material, after use, may have a particle concentration sufficiently high so that as much contamination is left on the component as is removed.
- c) Wiping or polishing action can cause particle adhesion as a result of electrostatic charges.
- d) Particles can be moved about on a component surface without necessarily being lifted from the surfaces.

- 2.5.3 In the wet cleaning process, the contaminated surfaces are exposed to clean fluid which will wet the particles and the surfaces. The fluid or the component is then agitated so as to pull particles from the surfaces. After a specified period the component is withdrawn and the surfaces are dried. The ways in which wet cleaning can contaminate include the following:

- a) It is often difficult to obtain clean fluid and to keep it clean when handling it.
- b) Agitation of the fluid is normally done by ultrasonic means, but there is a possibility of re-contamination of the amplitude if agitation is not large enough to remove particles an appreciable distance from the surface of the component.
- c) Often a wet surface may have particles in the liquid layer that can easily be moved laterally over the surface but are removed from the liquid layer only with great difficulty.
- d) Until the component is dried, any airborne particles will collect on the wet surface and remain.

2.6 **Personnel Activity**

The activity of personnel is probably the greatest single cause of contamination which arises from several sources. The act of walking, or other movements required at a work bench, produces transient air currents which re-distribute airborne particles and the brushing off of particles from many surfaces. Another contaminant source is the shedding of skin and hair particles. The outer layers of skin flake off almost continuously, the flake rate and size depending on the amount of abrasion to which the skin is exposed and its condition.

- 2.6.1 Exhaled air is another source of contamination since it contains moisture-retaining solid particles and is usually acidic in nature. Perspiration from the skin is a similar hazard.

3 Control of Contamination

Control of contamination is effected in two ways: by establishing a clean room, which will provide a clean atmosphere and working conditions and by rigid routines adopted by personnel to prevent process, transfer and associated sources of contamination while working within the area of the clean room.

- 3.1 The manufacture of a clean room and its air handling system (see paragraph 8) must be designed to control airborne particles over a range of sizes and suited to the nature of the work performed in the room. Control is accomplished by filtration of the air entering the room, changing the air to remove generated particles, designing walls, floors and furnishings to be resistant to particle generation and retention, protecting components from impact and settling of particles and providing additional areas for cleaning of parts and personnel.

4 Size of Contaminants

The degree to which contaminants are effectively controlled is determined by measurements of the size of particles and the number in a given volume. The conventional unit of measurement is the micrometre (μm). In general, the filtration systems of clean areas are designed to control particles of $0.5 \mu\text{m}$ and larger in size.

5 Classification of Air Cleanliness

In addition to all principles of air-conditioning, certain specialised cleanliness requirements are defined by standards which establish classes of contamination level to be achieved in the design of a clean room for a specific task. Classifications relate to the number of contaminant particles $0.5 \mu\text{m}$ and larger in size, present in one cubic metre of air. Four classes of contamination level are generally adopted and these are shown in descending order of cleanliness in Table 1. Special classifications may be used for particle count levels where special conditions dictate their use. A summary of the cleanliness requirements for some typical products is given in Table 2.

Table 1

Controlled Environment (Clean room, work station or clean box)	Recommended Air Flow Configurations	Recommended Periodicity for Air Sampling and Particle Counting	Max. Permitted Number of Particles per m^3 (equal to, or greater than, stated size)					Final Filter Efficiency %
			$0.5 \mu\text{m}$	$1 \mu\text{m}$	$5 \mu\text{m}$	$10 \mu\text{m}$	$25 \mu\text{m}$	
Class 1	Unidirectional	Daily or continuous by automatic equipment	3,000 ¹	Not applicable	Nil	Nil	Nil	99-995
Class 2	Unidirectional	Weekly	300,000	Not applicable	2,000	30	Nil	99-95
Class 3	Unidirectional or conventional	Monthly		1,000,000	20,000	4,000	300	95-00
Class 4	Conventional	3-monthly			200,000	40,000	4,000	70-00
Controlled Area	Normal ventilation	—	—	—	—	—	—	—
Contained Work Station	Unidirectional	To suit required class and application						99-997
Portable Clean Boxes	As selected	To suit required class and application	To suit required class					To suit required class

1. Subject to maximum particle size of $5 \mu\text{m}$

6 Classification of Clean Rooms

The cleanliness achieved by a clean room is dependent on the air-handling system's capacity to purge the room of contaminant particles. This includes not only effectiveness of the filters and the number of air changes per hour but also the distribution of the air within the room. There are two main methods of distributing air into clean rooms namely, conventional clean rooms and unidirectional-flow clean rooms, and these also serve as the basis of clean room classification.

6.1 Conventional Clean Rooms

Conventional clean rooms are based on recognised air-conditioning techniques. The conditioned air is highly filtered and distributed through ceiling-mounted diffuser outlets and then exhausted from return airducts located near the floor around the periphery of the room (see Figure 1). In addition to direct emission from the diffuser outlets, spreading of conditioned air throughout the room is obtained by secondary mixing of the air caused by thermal effects of warm and cool air currents. This is an advantage from the point of view of maintaining conformity of room temperature conditions, but the turbulence created gives rise to the problem of contaminant particles being re-introduced to the airstream.

Table 2

Class	Particles/m ³	Product
2	0.5µm to 10 µm	Air bearings Miniature ball bearings Miniature contacts Floated gyros Hydraulic and pneumatic systems Optics Semi-conductor networks Miniature timing devices
3	1 µm to 25µm	Hydraulic and pneumatic systems Precision timing devices Stable platforms Gyros
4	5µm to 25µm	Ball bearings Electronic components Engine pumps Aerospace instruments Printed circuits Valves Hydraulic and pneumatic systems Precision measuring equipment

NOTE: Class 1 is outside the scope of this Leaflet and would not normally be used.

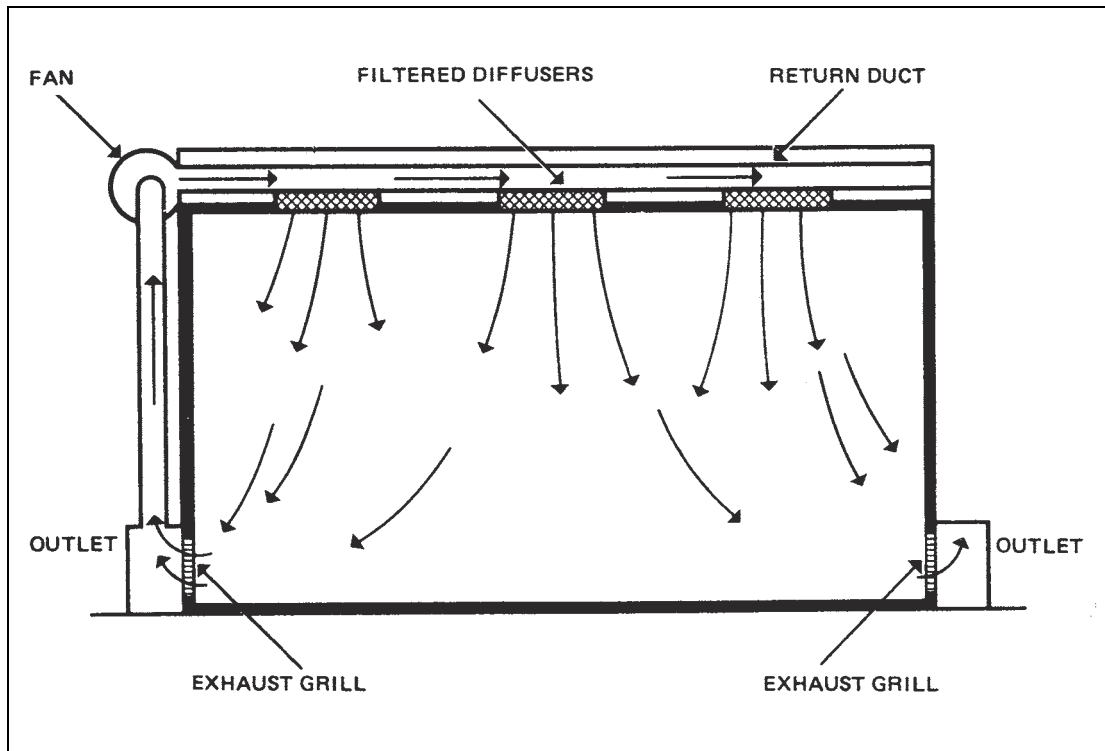

Figure 1 Conventional Flow System

6.2 Unidirectional-flow Clean Rooms

These rooms have been developed from the conventional type of clean room and are designed to overcome three primary deficiencies associated with it; lack of self clean-up capabilities to effect contamination brought in by personnel and equipment, non-uniformity of airflow patterns and the requirement for rigid control of personnel. The major differences between the layout and operation of the two types of clean room result from the method of air distribution adopted. In a unidirectional-flow room air is introduced through a large filtered diffuser area, moves through the room and is exhausted through an outlet opposite to the diffuser and of equally large area. Such an arrangement ensures that the air moves in a straight or unidirectional-flow. The outlet is connected to return air ducts thus permitting re-cycling of the air. Two alternative airflow systems exist and are illustrated diagrammatically in Figure 2. In the vertical unidirectional-flow (down-flow room) system, the diffuser forms the complete ceiling of the room and the floor is grated to provide the outlet to return ducts. The diffuser of a horizontal flow (cross-flow room) system forms one of the end walls of the room. After passing through the room and then through an exhaust grill, the air is deflected upwards into the return ducts.

- 6.2.1 In some designs the use of separate return ducting may be eliminated by adopting the twin cross-flow technique of air distribution as shown in Figure 3. The total clean room area required is divided in half by a wall, with flow in one direction on one side of the wall and flow in the opposite direction on the other side. The end walls are made up of filtered diffusers and exhaust grills and are disposed so that the clean room itself acts as a return duct.

7 Environment and Comfort Control

The temperature, humidity and pressure characteristics of the air passing through the air handling system (see paragraph 8) should be controlled to establish an environment suitable for work processes to be carried out in a clean room and for the comfort of clean room personnel.

7.1 Temperature and Humidity

The selection of temperature and humidity ranges to be controlled are dependent on the design of the component or system and the effects on their functional accuracy under varying environmental conditions. Normally a suitable temperature for working conditions is $20 \pm 2^\circ\text{C}$ ($68 \pm 36^\circ\text{F}$). Humidity should be controlled and maintained at a relative humidity of 35 to 50% for all classes of clean rooms, contained work stations and clean boxes.

7.2 Pressure

Clean rooms are always slightly pressurised in order to maintain the required outward flow of air under closed working conditions and to prevent the entry of contaminant airborne particles when entryways or doors are opened.

7.2.1 Unidirectional-flow rooms should normally have an air velocity of 0.45 ± 0.1 m/s for horizontal flow rooms and 0.30 ± 0.05 m/s for vertical flow rooms. Air pressure for conventional flow rooms should be such that the number of air changes, including re-circulated air, should not normally be less than 20 per hour except for Class 4 rooms where not less than 10 changes per hour may be acceptable.

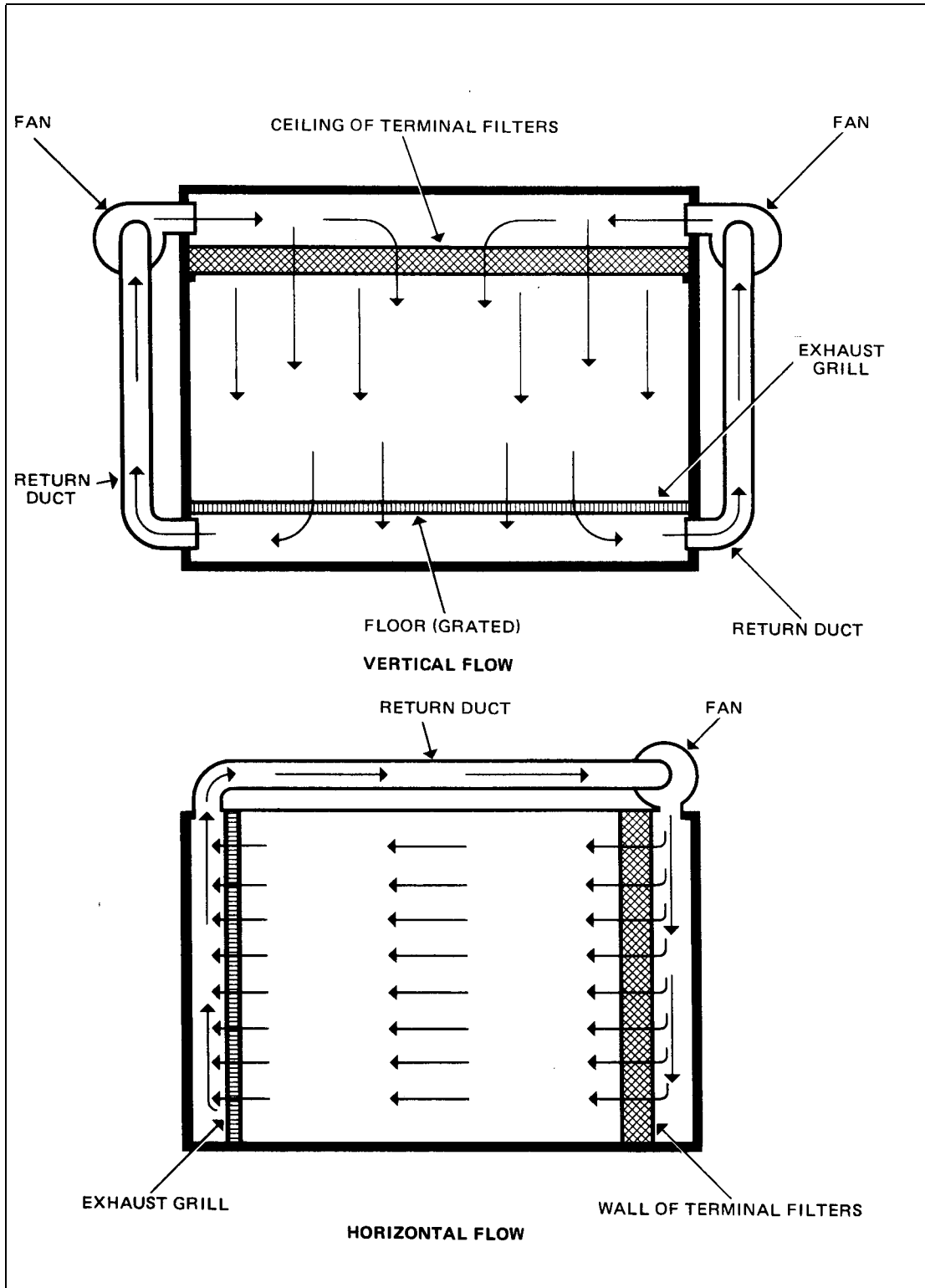

Figure 2 Unidirectional-flow Systems

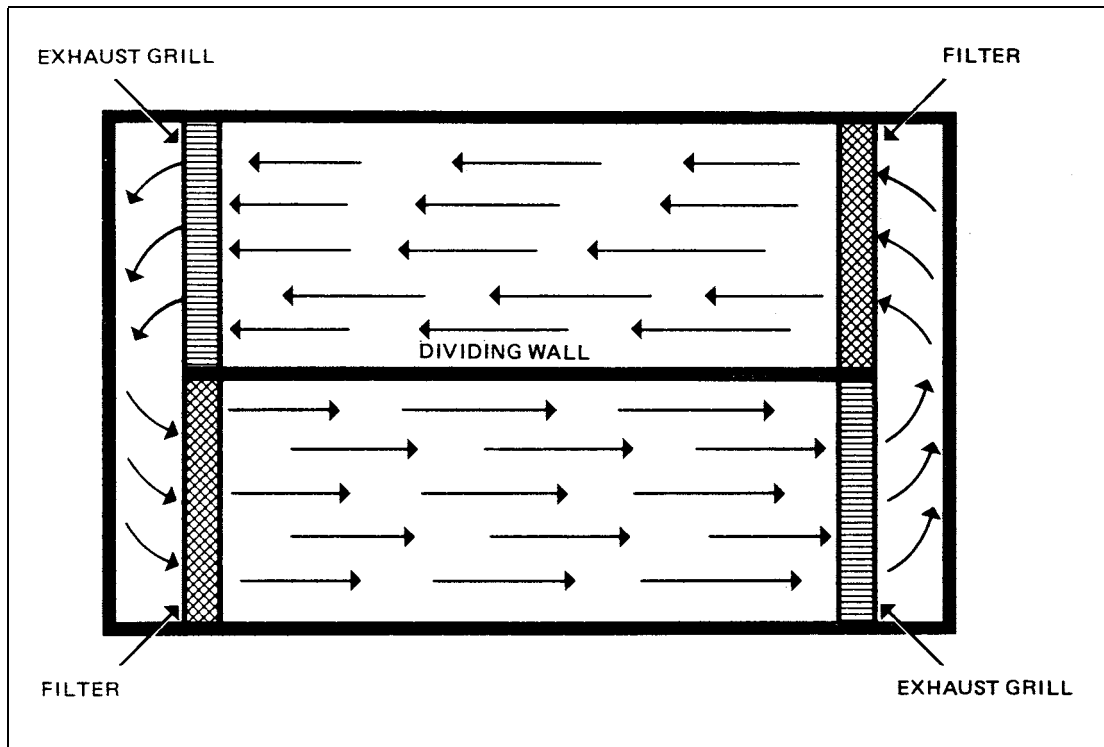

Figure 3 Twin Unidirectional Cross-flow System

- 7.2.2 Arrangements should also be made to ensure that excessive turbulence is not produced, and every precaution should be taken to obviate the possibility of contaminated air being carried back to the work stations. Contained work stations and portable work boxes should normally conform to the requirements of the type of air flow selected. Air pressure and graduations between successive pressure areas should not normally be less than 15 Pa (1.5 mm water gauge).

NOTE: 25 Pa (2.5 mm water gauge) is normally regarded as adequate but, when selecting the actual pressure, care should be taken to ensure that in-leakage is prevented.

8 Air Handling Systems

The primary function of an air handling system for any type of clean room is to control the level of airborne contaminant particles by constantly filtering and re-circulating the air. The arrangement of a system depends on whether it is to be a conventional clean room, unidirectional vertical or horizontal flow clean room. In the basic form, however, it consists of a fan, ducting for inlet and exhaust air and an air filtration system. In some instances, the use of ducting may be minimised by adopting a false ceiling arrangement and by blowing air through the plenum chamber formed between two ceilings, and also by adopting a twin cross-flow system (see paragraph 6.2.1). The air is conditioned to the required temperature and humidity values (see paragraph 7.1) by adopting recognised air-conditioning principles and by the integration of an appropriate air-conditioning plant.

8.1 Fans

Fans are usually of the electrically-operated type designed to deliver a constant airflow rate through the clean room as the filter pressure drop increases. They should be mounted external to the ducting, where possible, to avoid heat loading of the air

and introduction of further contamination. Care should also be taken to avoid contamination of the atmosphere by gaseous effluents.

8.2 Ducting

Ducting is manufactured from materials which are non-flaking and corrosion-resistant, stainless-steel and aluminium being commonly used, or should normally be treated to prevent the introduction of contaminants from the duct.

8.3 Filtration System

Filtration of airborne contaminant particles is selected on the basis of cleanliness level required and, generally, a system is made up of two principal stages: pre-filter stage and final filter stage. Pre-filtering is carried out at the inlet to the air handling system and at one or more points upstream of the clean room, and final filtering directly at the inlet to the clean room. The filters are specifically designed for clean room systems and are graded at each stage, thus providing control of diminishing size particles. Filtering action depends on the particles contacting and adhering to the fibres or collecting surface of the filter medium which is made from such materials as glass-fibre and asbestos. The filters utilised for final filtering are variously known as super-inception, absolute or high-efficiency particulate air (HEPA) filters and may be used as individual units or assembled to form a filter bank or module. In the latter case, each unit is connected to a common plenum chamber incorporating its own fan. The number of individual units in a bank is governed by design requirements for the air handling system.

9 Layout of Clean Rooms

The layout of a clean room is governed by many factors arising principally from the manufacturing processes and test procedures to be carried out on specific types of equipment. As a result there are a variety of design and layout specifications to meet the requirements of individual manufacturers and operators of equipment. In their basic form, however, layouts are directly related to the accepted methods of air distribution, i.e. unidirectional-flow and conventional.

9.1 Unidirectional Clean Rooms

The layout of a typical clean room facility is illustrated in Figure 4. The area devoted to the facility is arranged in accordance with the operating practices common to all clean rooms, i.e. components and personnel flow progressively from an uncontrolled or 'dirty' environment to one in which the desired level of cleanliness is maintained.

9.1.1 Personnel Cleaning

Entrance to the clean room is via a change room the purpose of which is to decontaminate personnel without introducing removed contaminant particles into the clean room. A change room is divided into three distinct areas; an uncontrolled or 'dirty' area, a wash-up (semi-contaminated) area and a change (uncontaminated) area. These areas are arranged so that personnel must follow a definite path for entry into the clean room.

- a) In the uncontrolled area lockers are provided for housing outdoor clothing such as overcoats and raincoats, and also shoe cleaning machines. From the uncontrolled area, entry to the wash-up area is made via an air shower compartment, the purpose of which is to remove gross contaminant particles from personnel. The size of the compartment may be large enough to accommodate only one person or a group of persons depending on the number that must enter the clean room in a given length of time. The design of the air shower may vary but, in general, it

consists of an air inlet system and an exhaust system operated by independent fans. Air flows through the compartment from air inlet nozzles or louvres mounted in the ceiling or in one wall of the compartment. The entrance and exit doors of the compartment are interlocked so that only one of them can be opened at a time. The closing of the entrance door starts the fan and, until the cleaning cycle is completed, the exit door remains locked. The cycle may, in some cases, be interrupted by a safety override system in the event of an emergency. Air velocities are sufficiently high to cause 'flapping' of clothing but without discomfort to personnel.

- b) On leaving the air shower, personnel proceed to the change area via the semi-contaminated area in which washing and toilet facilities are located. These facilities include foot-controlled washstands, liquid-soap dispensing units and heated air hand-drying machines to prevent contamination from towelling. A section of the change area is provided for changing into special clean room garments (see paragraph 12) stored in racks or lockers. The entrance to this section is guarded with a tacky or sticky mat designed to remove residual contaminant particles from the undersurfaces of shoes. Entrance to the clean room after changing is made via another air shower compartment.

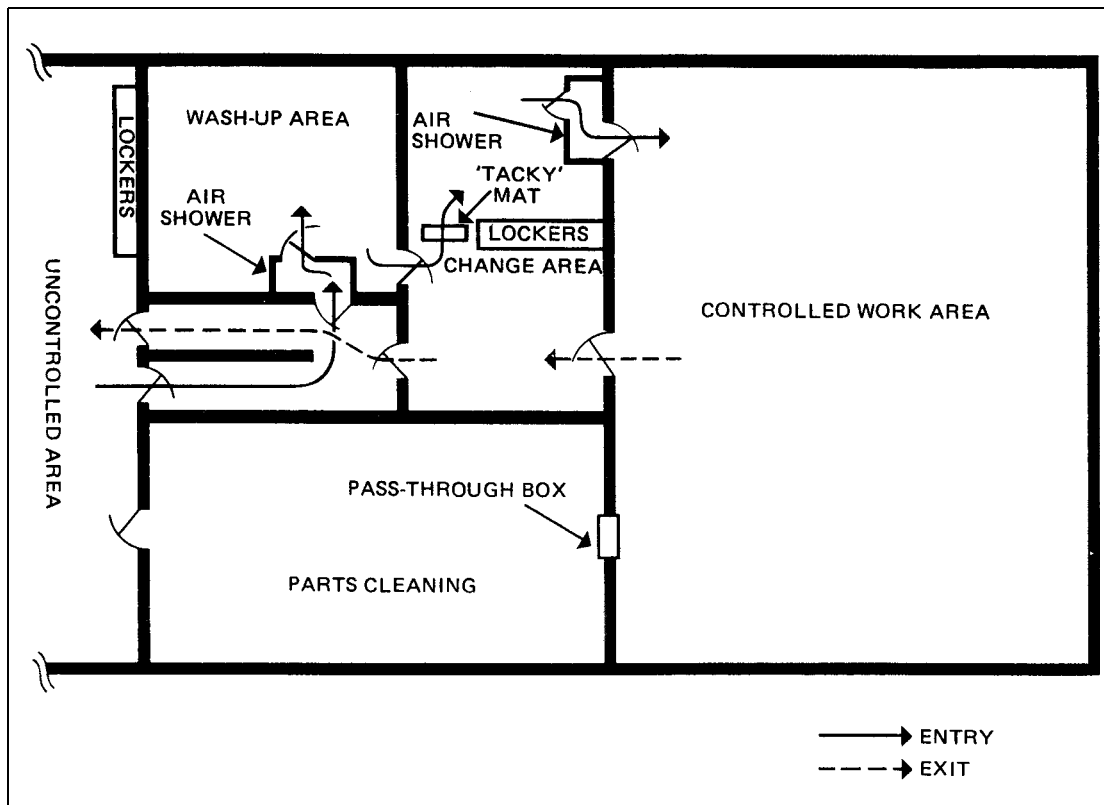

Figure 4 Layout of a Unidirectional Clean Room

9.1.2 Parts Cleaning

Prior to entry into a clean room, all parts, tools, equipment, and material must also be decontaminated and it is therefore necessary to provide an additional area adjacent to the clean room. The layout of a parts cleaning room depends largely on the types of component and the number of work processes involved. Similarly, the cleaning methods adopted depend on the type of contaminant, the materials used in the manufacture of components, and the level of cleanliness required. In general, the

room is equipped with the required number of work tables, specialised equipment, cleaning machines and washing facilities for personnel.

- a) The transfer of cleaned components to the clean room is effected by means of a 'pass-through' box forming an air lock in the wall dividing the appropriate areas. Boxes are provided with double windows and doors; an interlock system ensures that only one door can be opened at a time. In some clean room facilities a 'pass-through' box may be of the circular type with a single opening so that the box must be rotated through 180° to insert or remove a component. Since the boxes are designed to prevent a direct opening between rooms, a means of verbal communication between relevant personnel must be provided adjacent to the box. This can be an intercommunication system, a voice diaphragm, or a speaking tube.

9.1.3 **Additional Support Rooms**

Since unidirectional clean rooms require more rigid control to prevent contamination entering, it is usual to make provision for additional support rooms such as offices, lunch rooms, rest rooms, etc. The manufacture of these rooms follows a similar pattern to that of a clean room (see paragraph 10) although the air handling system is usually not so elaborate.

9.2 **Conventional Clean Rooms**

The use of conventional flow clean rooms eliminates the necessity for support areas such as air showers and special changing rooms and, as may be seen from the typical conventional layout illustrated in Figure 5, increased working area is available and entry procedures are much simpler. The main entrance is situated at the air outlet or 'dirty' end of the room and personnel can pass through this directly from a locker room and change area. Work benches and equipment are disposed so that the cleanest operations are carried out closest to the filter bank forming the end wall, while dirty operations such as soldering, cleaning, etc., are performed toward the outlet end of the room. Parts cleaning and preparation may be performed in a manner similar to that adopted for a unidirectional clean room (see paragraph 9.1.2) or carried out in a parts cleaning room situated within the clean room itself.

10 **Manufacture of Clean Rooms**

The manufacture of clean rooms involves the application of specifically developed building techniques, air-conditioning installation practices and careful selection of manufacture materials. This is normally undertaken by a specialist organisation working to the detailed BS EN ISO 14644-2: 2000, 14664-4: 2001, 14664-5: 2004 and the specification of a user organisation. The details given in the following paragraphs are therefore intended as a guide to the factors related to general constructional features.

10.1 **Noise and Vibration**

Careful consideration must be given to clean room location in relation to other work areas and the effects of noise and localised ground vibrations. Noise and vibration generated by equipment, machinery, support and administrative areas must also be considered. If vibration insulation devices are to be employed these must not generate or collect dust. Special attention must be given to the framing system of super-structures in order to prevent vibration transmission through ceilings, walls and floors into the main structure. The maximum noise level of the room, work station or clean air device, in an operational but unmanned state should not normally exceed 65 dB.

10.2 Floors

Floors should have long life and be highly resistant to breakdown under the shear forces created when personnel walk across them. Vinyl is particularly suitable for floors since it is tough and resilient. Floors should have a smooth surface which is easy to clean and will not collect dust. The junction between floors and walls should be radiused to facilitate cleaning operations. Joints between floor sections should be tight and sealed.

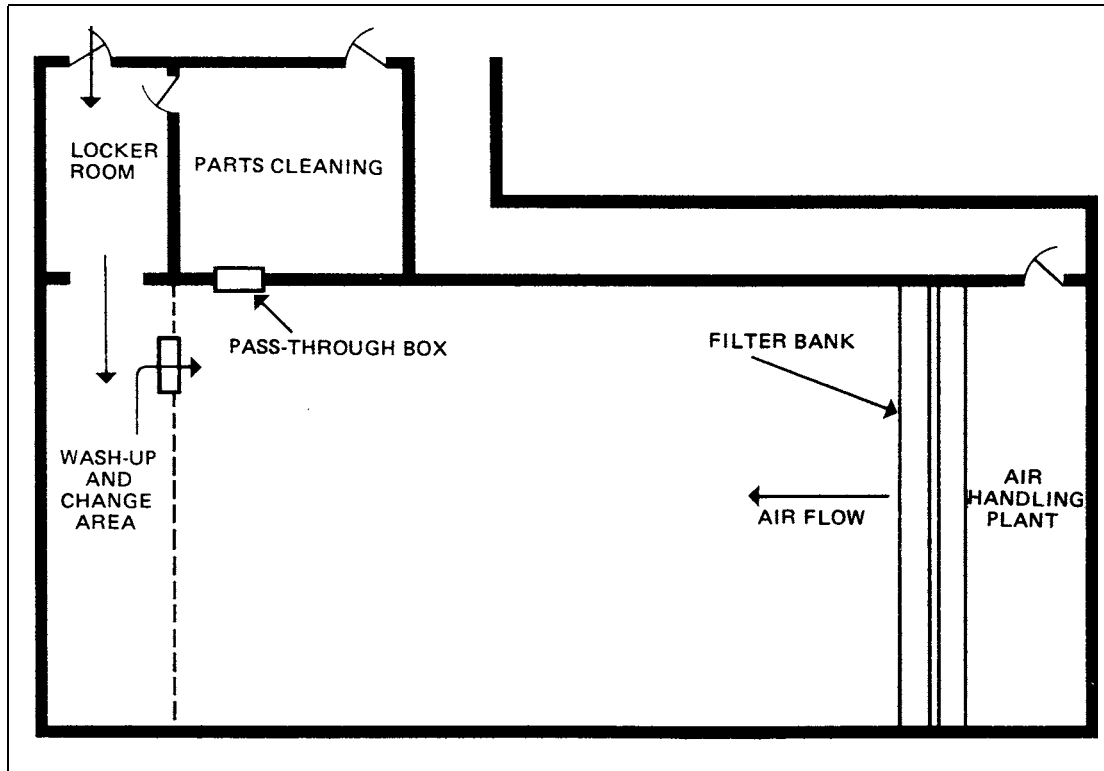

Figure 5 Layout of a Typical Conventional Clean Room

10.3 Walls

Walls should be covered with materials which will produce a smooth, durable surface which does not chip or flake. Stainless steel, vinyl coating, high-gloss paint, melamine decorative laminate, painted hardboard and tiles are some of the materials which are suitable. Window frames, doors and door frames may be manufactured of steel, aluminium or other highly durable material, and should be set flush with the interior of the walls. The use of timber in structural elements is discouraged because it is unstable in areas where there is a change in humidity. The introduction of large volumes of console type equipment can increase the heat load of a clean room and provide possible collection and sources of contamination. Such equipment may be built into a wall thus placing the heat load outside the room and also permitting maintenance of the equipment without the necessity of entering the clean room. Gaskets should be fitted around the equipment to prevent excess loss of room air.

10.4 Ceilings

Since ceilings are not subjected to potential impact, they may be surfaced with any material that is easily cleaned and does not produce or collect dust. Ceiling panels should be provided with gaskets and clamped to ensure adequate sealing, allowance being made for subsequent removal and replacement.

10.5 **Lighting**

Lighting fixtures of the fluorescent type should be used and of ratings which will provide adequate light intensity at bench level of not less than 3,000 lux. Fixtures may be installed to permit servicing from within the clean room, or supported in tracks above the ceiling so that they can be slid out for servicing without entering the clean room.

10.6 **Utilities**

The distribution of utilities such as water, electrical power, vacuum and compressed air supplies must be properly planned to ensure that all required work locations are served without interference with room air distribution and work flow.

11 **Clean Room Furnishings**

Furnishings such as work benches, chairs and containers for component parts require careful selection, design and choice of materials for their manufacture. The main structure of work benches and chairs should be of metal and designed in such a way that contaminant particles cannot accumulate. Items that can expect to be bumped, knocked, abraded, etc., by personnel should possess a tough, resilient, low-particle generating surface such as stainless steel, melamine decorative laminate type material, or material of equivalent surface qualities.

12 **Clean Room Garments**

Clean room products can be readily contaminated by particles from clothing and it is therefore necessary to make provision for the wearing of protective garments. These take the form of smocks, overalls, caps and hoods. In addition, 'boottee' type shoe covers, separate clean room shoes and gloves must also be provided. The extent to which all the garments are used depends on the type of clean room, class of cleanliness to be achieved and the work processes carried out.

12.1 **Design**

The garments are of special design to prevent the transfer of contaminant particles from personnel and at the same time to provide the maximum of comfort. The materials from which they are fabricated are usually selected from the range of available man-made fibres which exhibit such properties as non-flammability, limited linting, and negligible electrostatic generation. These materials are available under a variety of trade names. Typical design requirements for clean room garments are given in the following paragraphs.

12.1.1 **Smocks**

Smocks should be of simple design, with no pockets and with as few seams as possible. Seams should leave no open end of material which might become frayed and give off lint or loose strands. In addition, seams should be double-stitched with thread of the same fibre as the garment. Adjustable neck bands and cuffs should be provided in preference to collars and loose sleeves and must provide a snug fit when worn.

12.1.2 **Overalls**

Overalls should have a full-length zip fastener with flap front and be provided with adjustable neck bands and cuffs. If overalls are to be used with shoe covers, the overalls should fit inside the covers. Overalls to be used with clean room shoes

should be designed so that the legs of the overalls meet and slightly overlap the shoes.

12.1.3 **Caps**

These should be of the style worn in hospital operating rooms. They should fit snugly around the head, covering the hair to prevent hair particles and dandruff falling into the clean room area.

12.1.4 **Hoods**

Hoods should be designed to confine all hair under them to eliminate contamination by hair particles and dandruff, and to fit snugly inside overalls to provide complete coverage of personnel; if beards are permitted, masks must also be provided.

NOTE: Garments are usually white although in some cases a sea green colour may be chosen to minimise glare. As a means of identifying selected personnel, e.g. supervisors or personnel in charge of certain work processes, smocks and overalls may be provided with distinctively coloured neckbands. Coloured caps may also be used as a means of identification.

12.1.5 **Shoe Covers and Shoes**

Covers should be worn over normal shoes and should be high enough to hold the legs of overalls. Covers should have a reinforced sole and be of a type which will prevent personnel from slipping and falling on smooth floors and, for reasons of durability and economy, nylon is recommended as the material. To provide proper fit and comfort, and to achieve optimum cleanliness, covers should be provided with snap fasteners, and laces which can be tied around the legs and above the ankles. As an alternative to shoe covers, shoes can be issued to personnel for exclusive wear in the clean room. They should be simply designed, comfortable, washable and fabricated from materials which will not shed particles due to abrasion and wear.

12.1.6 **Gloves**

Where there is a risk of contamination from contact with the hands or fingers, gloves or finger stalls must be used. Such coverings should be comfortable and should enable the user to maintain a delicate finger touch. If the use of plastics is necessary for the 'touch' portion of gloves the remainder should be made of a material that will allow 'breathing' thus preventing overheating of the hands.

12.2 **Garment Storage and Cleaning**

When not in use, clean room garments should not be allowed to come into contact with any possible contaminant. They should always be stored on individual hangers in the lockers provided in changing rooms. Three sets of garments per person should normally be provided: one set in use, one set being cleaned, and one set in reserve.

12.2.1 Cleaning of garments is a specialised technique based on conventional laundering and dry-cleaning processes. Ideally, a laundry should be established as a specialised unit supporting clean room operations and functioning under similar conditions of decontamination as a clean room. A typical unit is divided into three distinct areas: soiled garment receiving area, washing and dry-cleaning area, and an inspection and packaging area. Soiled garments are placed in polythene bags and transferred to the receiving area through an air lock. The garments are then emptied into specially built tubs and transported to the washing and dry-cleaning area equipped with the appropriate machines. After cleaning and drying, the garments are transferred to the third area for inspection, sampling of contamination level, and packaging and sealing in polythene bags.

13 Clean Work Stations

These stations are work benches specifically designed to incorporate their own filtered air supply system. They may be utilised in a clean room, in addition to benches or tables based on conventional patterns, or in an uncontrolled environment.

- 13.1 The design of work stations has been developed from bench-mounted 'dust-free' cabinets, typical examples of which are illustrated in Figure 6. Although these cabinets provide low contamination levels, depending on the type of filter, the problem of contamination while operations are performed inside arises. Contaminants move about in turbulent air and find their way out of the cabinet only at random intervals. Another design, commonly referred to as a 'glove box' is also illustrated in Figure 6. It utilises a recirculating air system and although it produces lower contamination levels than other forms of cabinet, it has the disadvantage of requiring an operator to work through arm ports and the attached gloves.

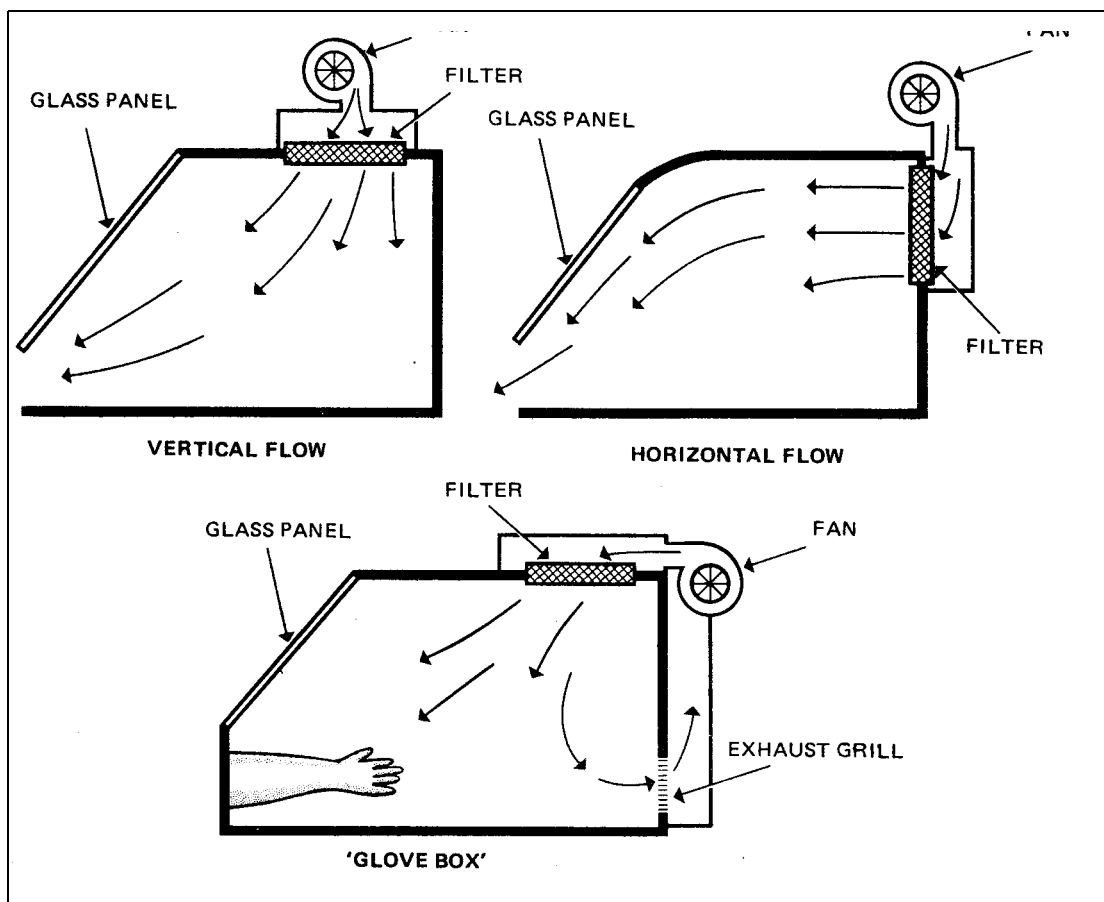

Figure 6 Clean Work Boxes

- 13.2 Work stations overcome the deficiencies of 'dust-free' cabinets by incorporating an air distribution system which operates on principles similar to those employed in a unidirectional-flow clean room (see also paragraph 6.2). The air distribution system consists of a fan and a pre-filter mounted below the work surface, and an outlet with a super-interception filter, mounted so as to produce either a horizontal flow or a vertical flow over the work surface. Figure 7 illustrates both airflow techniques as they are applied to a typical console type of work station. Glass panels form the sides of the work area which, on account of the unidirectional-flow technique, is open at the front thus permitting unrestricted movement at the work surface. Illumination of the

work area is provided by lighting units enclosed in the canopy above the work surface. Individual switches for lighting units and fans are located at convenient points as also are the controls for the various services required for relevant work processes.

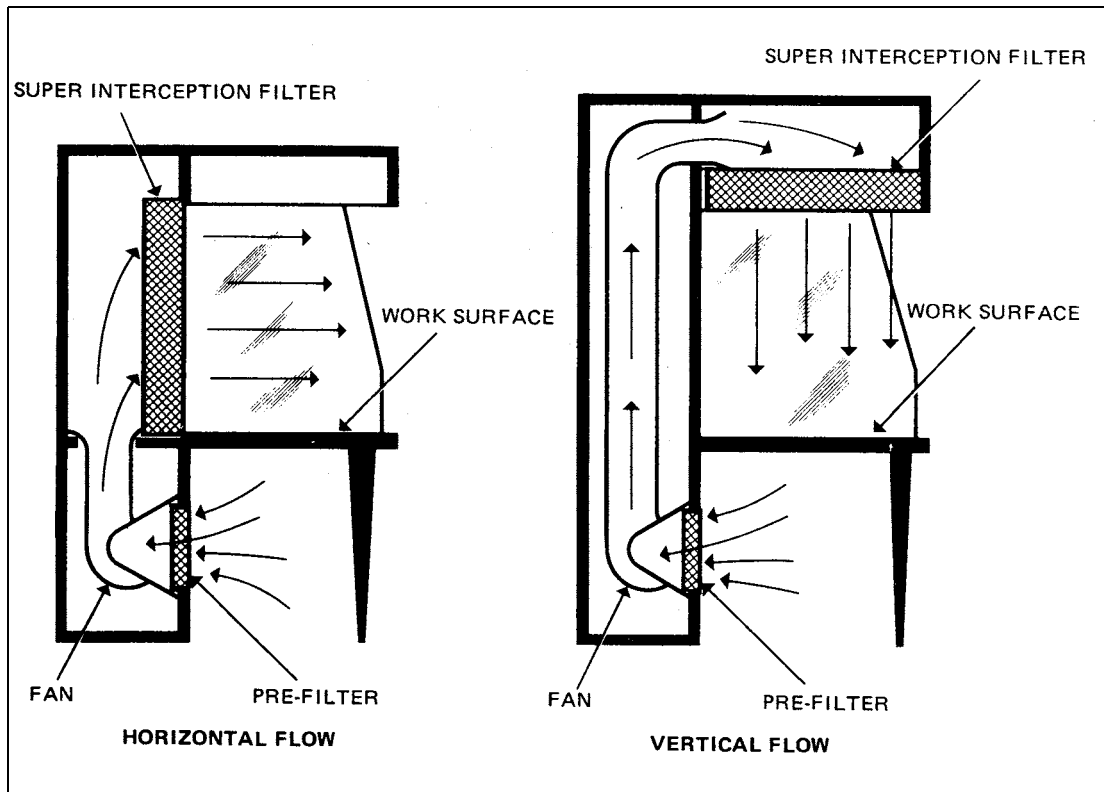

Figure 7 Clean Work Stations

- 13.3 The selection of a work station best suited to a specific application involves such factors as type of airflow, size of work area, space available, and design and performance of the air distribution system. Units employing horizontal flow are generally less costly than vertical flow units for equal size of work area and can usually be provided with lower overall heights thus making them more suitable when vertical space is a critical factor. When work processes require the exhausting of fumes from the work area, or when recirculation of the air is required, vertical flow units provide for these functions more easily than horizontal flow units. Horizontal flow units, on the other hand, provide better 'clean-up' of a work area than vertical flow units of equal size.
- 13.4 The most important consideration in selecting a particular size of work station is to ensure that it will provide unidirectional-flow over a work area of sufficient width, depth and height to accommodate the component being assembled or tested, and the necessary associated equipment. If several items of equipment must be sited around a component, a vertical flow unit tends to produce less turbulence and moves clean air in the most direct fashion from the filter to the component. The filters are of a type similar to those used in unidirectional clean rooms (see paragraph 8.3).

14 Clean Room Operation

In addition to the air handling system, the contamination level in a clean room is kept at an acceptable level by two other methods, namely limiting the contamination entering the room and limiting the contamination generated within the room. Both

these methods are controlled to a large extent by the personnel selected for clean room operations. The contamination entering the room is limited by the wearing of proper garments (see paragraph 12), personnel cleaning, parts and equipment cleaning, etc. The contamination generated is limited by restricting movement, proper work techniques, etc. It is therefore necessary to establish routines and disciplines related to personnel selection, personal hygiene, entry procedures, and control of working activities. The extent to which certain of these routines and disciplines are applicable depends on the type of clean room; for example, a unidirectional-flow clean room requires more rigid control of entry and clothing procedures than a conventional clean room due to the air handling system used (see paragraphs 9.1 and 9.2).

14.1 **Personnel Selection**

The selection of personnel for clean room duties involves consideration of both physical and human factors, including manual dexterity, visual acuity, patience, concern for detail, attitude toward repetitive operations and reaction to the rigid disciplines that accompany confinement in a controlled environment. Certain physiological problems must also be considered and some examples which are detrimental to clean room operations are: allergies to synthetic fabrics; allergies to solvents used in cleaning processes; profuse nasal discharge; skin conditions that result in above normal skin shedding or flaking and dandruff; high amounts of acid found in the hands; severe nervous conditions such as itching, scratching or claustrophobia.

14.2 **Personal Hygiene**

The development of personal hygiene is of great importance in clean room operations, not only to limit contamination of vital components but also to maintain a healthy working environment. Personnel with colds, temporary coughing and sneezing, should be assigned to temporary jobs outside the clean room until they are sufficiently recovered. This also applies to personnel having received severe sunburn, to prevent peeling skin from contaminating a component or the surrounding area.

14.3 **Entry Procedures**

Clean rooms are necessarily restricted areas and entry must only be allowed to personnel assigned to them. The procedure to be adopted is governed by the type of clean room. Typical activities associated with entry procedures are as follows:

- a) Removal of outdoor clothing such as overcoats and raincoats and stowage in the lockers provided in the 'dirty' or uncontrolled area.
- b) Checking clothes and shoes for visible contamination such as mud, dirt, sand, etc. Removal of such contamination.
- c) Washing of face and hands using foot-controlled washstands, liquid soap dispensers and air driers.
- d) Passing through air showers and air locks to ensure adequate air scrubbing.
- e) Walking over sticky or tacky mats.
- f) Changing into the requisite clean room garments. In connection with unidirectional-flow clean room operations, changing is done in the uncontaminated section of the change room adjacent to the clean room. In conventional clean rooms changing is done in an area located at the 'dirty' end of the clean room.

14.4 **General Rules for Operation**

The following are general rules which should be enforced to assist in the successful operation of clean rooms.

14.4.1 **Personal Activities**

- a) Hands should be washed often and fingernails kept clean.
- b) The specified clothing should always be worn in the approved manner.
- c) Personal items such as keys, coins, cigarettes, matches, pencils, handkerchiefs and combs should be deposited in lockers prior to changing into clean room garments. Valuable items such as wallets may be carried into a clean room in jacket or trouser pockets provided they are not removed inside the clean room.
- d) Foodstuff should not be taken into a clean room.
- e) Smoking is strictly forbidden.
- f) The wearing of jewellery such as large rings, bracelets, watches, necklaces, earrings, locketts, etc., should be avoided.
- g) Nervous mannerisms such as scratching the head, rubbing of hands or similar actions should be avoided.
- h) Movement of personnel should be restricted as much as possible to prevent stirring settled particles on the clean room floor. This applies particularly to conventional clean rooms.
- i) Solvent contact with hands should be avoided as many solvents remove natural skin oils causing excessive skin 'peeling' or flaking.
- j) Female personnel should not wear or apply fingernail polish or cosmetics in a clean room.
- k) Visitors or clean room maintenance personnel must be authorised to enter a clean room and must follow the specified entry procedures.

14.4.2 **Work Activities**

- a) All tools including personal tool kits should be kept clean and in good condition and should undergo cleaning processes in accordance with a periodic cleaning schedule. Tools not essential to specific work processes should be excluded from tool kits.
- b) Paper materials should not be allowed in a clean room unless the paper is plastic-coated or covered, sprayed to prevent linting or is a special limited-linting paper. Papers should not be subjected to excessive shuffling, handling, rolling or bending as they can generate excessive amounts of small particles under these conditions.
- c) Pencils and erasers are not allowed. All writing should be with ball-point pens.
- d) Parts of components should be kept in their individual containers until ready for assembly. They should not be left exposed on a work bench or station.
- e) Containers and any component parts surplus to requirements should always be returned to a parts cleaning area for cleaning and re-issue.
- f) Metal objects such as wire clippings and solder splashes should be deposited in waste boxes at the end of each process.
- g) Where cleaning of parts is to be carried out inside a clean room, the type of cleaning equipment and its location within the room should be carefully selected.

15 Maintenance of Clean Rooms

In order to maintain clean rooms to the necessary standards, good housekeeping practices and monitoring of the air handling system are of prime importance. The frequency of cleaning is usually determined by taking into account the change in contamination level that can occur due to the cleaning operation, and the number of air changes per hour. Monitoring of the air handling system should be carried out at the time a clean room is put into initial operation and at regular periods thereafter, when filters have been changed, and when it is evident that down-grading of its operating level is taking place (see Table 3).

Table 3

Controlled Environment	Sampling for Particulate Contamination	Temperature	Humidity	Air Pressure
Class 1	Daily or continuous by automatic equipment	Continuous	Continuous	Continuous
Class 2	Weekly	Continuous	Continuous	Continuous
Class 3	Monthly	4-hourly	4-hourly	Continuous
Class 4	3-monthly	12-hourly	12-hourly	Continuous
Contained Work Station	Daily or to suit the product or as Class 2	Dependent on use		Not applicable
Controlled Area	Dependent on use	To meet requirements of personnel and product		Not applicable

15.1 Cleaning

Rooms should be cleaned when no work processes are being performed. Minor dry floor and bench vacuuming can be done, if necessary, during normal room operation if the equipment and procedures used ensure a minimum of disturbance to settled particles.

- 15.1.1 Cellulose mops and sponges can be used with water which meets specific particle-count requirements. High-grade plastics buckets which are not subject to flaking should be used. If ladders are required, they should preferably be of the anodised aluminium type. The use of detergents should be restricted to those which produce the minimum amount of residue after drying. For vacuum cleaning, a central vacuum cleaning system or a specially designed portable vacuum cleaner should be employed.
- 15.1.2 Cleaning apparatus and utensils are prevalent sources of contamination and their movement in and out of clean rooms should be carefully scheduled. They should be thoroughly cleaned and vacuumed prior to their entry.
- 15.1.3 The responsibility for cleaning work benches or stations should be delegated to personnel assigned to the benches to prevent improper handling of components and equipment by room maintenance personnel.
- 15.1.4 Inspection, maintenance and testing of air handling system components should be carried out in accordance with the relevant maintenance instructions, at periods determined by the type of clean room operations, and when downgrading of the contamination level begins to occur.

15.2 **Monitoring of Clean Rooms**

Monitoring refers to the procedures adopted for checking the factors influencing clean room environment. Such factors are the level of contamination, temperature, humidity and pressure. The exact requirements for monitoring and methods to be employed depend on the type of clean room and classification of cleanliness level, and are therefore determined on an individual basis (see Table 3).

15.2.1 **Contamination Monitoring**

This is the most difficult monitoring problem of clean room operation owing to the variations in contamination level throughout a room and also to the many factors which must be considered in selecting a specific monitoring technique. Some of the factors causing variations in contamination level are: filtered air entering a room at one or more locations; contamination being generated in various amounts throughout a room; contaminated air exhausted from a room at one or more locations. The highest level of contamination is not necessarily at the air exhaust locations, since air from a highly contaminated area may be diluted with filtered air prior to its being exhausted. Higher and lower levels of contamination can thus readily exist within a given room. The areas of most concern are those immediately surrounding the component on which work processes are to be carried out.

- a) The locations within a clean room at which sampling of the air is to be taken should be carefully considered in order to obtain a representative contamination level. Samples should be taken at identical times or as near as possible, since contamination levels of areas vary at different periods.
- b) Various techniques may be applied to contamination monitoring and some of those most widely accepted, together with details of principles, are listed in BS EN ISO 14644-2: 2000, 14644-4: 2001 and 14644-5: 2004.

15.2.2 **Humidity Monitoring**

This may be achieved by the use of conventional wet and dry bulb thermometers and psychrometric charts. The thermometers may be supplemented, if necessary, by automatic recording devices. Humidity can become troublesome if it is allowed to reach a level where static charges are generated by personnel or where corrosion may be a problem. In general, a humidity level of not less than 40% is desired. For those components where humidity tolerance is critical, special control measures should be employed.

15.2.3 **Pressure Monitoring**

A clean room should always be slightly pressurised and it is therefore necessary to monitor the pressure difference between the room and its outside surroundings. Monitoring may be achieved by a simple U-tube manometer, or a differential pressure gauge calibrated in mm water gauge.

INTENTIONALLY LEFT BLANK

Leaflet D-40 Storage Conditions For Aeronautical Supplies

1 Introduction

This Leaflet gives guidance and advice on acceptable conditions of storage which may be used, in the absence of manufacturer's recommendations, for specific aeronautical materials and parts. Subject headings are as follows:

Paragraph	Subject	Page
1	Introduction	1
2	General Storage Conditions	2
3	Storage Conditions for Specific Materials and Parts	4
3.1	Ball and Roller Bearings	4
3.2	Aircraft Batteries	5
3.3	Braided Rubber Cord	7
3.4	Compressed Gas Cylinders	7
3.5	Electrical Cables	8
3.6	Fabric	8
3.7	Forgings, Castings and Extrusions	8
3.8	Instruments	8
3.9	Oil Coolers and Radiators	9
3.10	Paints and Dopes	9
3.11	Pipes	9
3.12	Pyrotechnics	9
3.13	Rubber Parts and Components Containing Rubber	10
3.14	Sheet, Bar and Tube Metal	13
3.15	Sparking Plugs	13
3.16	Survival Equipment	13
3.17	Tanks (Flexible)	14
3.18	Tanks (Rigid)	15
3.19	Timber	15
3.20	Transparent Acrylic Panels	15
3.21	Windscreen Assemblies	16
3.22	Wire Rope	17

- 1.1 The correct handling of materials, especially the high strength aluminium alloys, is of extreme importance. Great care is necessary during loading and unloading and storage at the consignee's works to ensure that the material is not damaged by chafing, scratching, bruising or indentation, and that it is not excessively strained by bending, otherwise the mechanical properties of the material may be seriously affected. Heavy forgings, extrusions and castings should be carried and stored singly, ensuring that there is adequate support to maintain the material in its intended shape without strain.

2 General Storage Conditions

The conditions of storage of aircraft supplies are important. The premises should be clean, well ventilated (see paragraph 3.13) and maintained at an even dry temperature to minimise the effects of condensation. In many instances the manufacturer will specify the temperature and relative humidity in which the products should be stored. To ensure that these conditions are maintained within the specified range, instruments are used which measure the temperature and relative humidity of the store room.

2.1 Temperature and Relative Humidity

When required, the temperature and humidity should be checked at regular intervals by means of a hygrometer which measures the amount of humidity in the atmosphere. The wall-type of hygrometer is normally used and consists of wet and dry 'bulbs'; the dry bulb records the actual temperature, and a comparison between this reading and that registered by the wet bulb, when read in conjunction with a table, will indicate the percentage of relative humidity present in the atmosphere.

2.2 Protective Materials for Storage Purposes

2.2.1 Vapour Phase Inhibitor (VPI)

This is a method of protection against corrosion often used for stored articles made of ferrous metals.

- a) VPI protects by its vapour, which entirely covers any article in an enclosed space. Direct contact of the solid VPI with the metal is not required. Although moisture and oxygen are necessary for corrosion to take place, VPI does not react with or remove either of them, but operates by inhibiting their corrosive action.
- b) The method most commonly used is treated paper or board, the article to be protected being wrapped in paper which has been treated with VPI or, alternatively, enclosed in a box made of VPI treated board, or lined with treated paper.

NOTE: Protection of parts by the VPI process should only be used where it is approved by the manufacturer of the part.

2.2.2 Protective Oils, Fluids, Compounds

Where oils, fluids or compounds are used as a temporary protection on metal articles, it should be ascertained that the material and the method of application is approved by the manufacturer of the article. Where protective oils, fluids or compounds have been used, deterioration of such fluids or compounds by handling can be minimised by wrapping in a non-absorbent material (e.g. polythene, waxed paper), which will normally increase the life of such temporary protectives by inhibiting drying out. When parts or components are stored for long periods they should be inspected at intervals to ensure that the condition of the coating is satisfactory.

2.2.3 Desiccants

The desiccants most commonly used in the protection of stored parts or components are silica-gel and activated alumina. Because of their hygroscopic nature these desiccants are capable of absorbing moisture either inside a packaging container or a component, thereby preventing corrosion.

- a) Desiccants should be inspected and/or renewed at specified periods or when an airtight container has been opened. It is important when inspecting or changing a desiccant that the prescribed method is used to avoid the entry of moisture into a dry container.
- b) **Tell-Tale Desiccant.** This indicating type of desiccant is prepared with a chemical which changes colour according to its moisture content. The following table gives guidance on the relative humidity of the surrounding air.

Colour	Surrounding Relative Humidity (%)	Moisture Content of Silica-Gel %
Deep Blue	0.5	0.2
Blue	10	5.5
Pale Blue	20	7.5
Pinkish Blue	30	12.0
Bluish Pink	40	20.2
Pink	50	27.0

- c) Silica-gel and activated alumina can be reactivated by a simple heat treatment process. The time and temperature required to effectively dry the desiccant should be verified with the manufacturer, but a general guide is 135°C for at least 2 hours for silica-gel and 250°C for 4 hours for activated alumina. The desiccant should then be placed in a sealed container until it has cooled, after which it should be completely reactivated.

2.3 Racks and Bins

Open racks allow a free circulation of air and are preferable when the nature of the stock permits their use. The painted metal type of bins is more suitable than the wooden type, since with the latter there is a risk of corrosion due to mould or dampness. Polyethylene, rigid PVC, corrugated plastics or cardboard bins may also be used. Many moulded plastics bins can also be fitted with removable dividers which will allow for the segregation of small parts whilst making economic use of the space.

2.4 Rotation of Issue

Methods of storage should be such that batches of materials or parts are issued in strict rotation, i.e. old stock should be issued before new stock. This is of particular importance for perishable goods, instruments and other components which have definite storage limiting periods.

2.5 Storage Limiting Period

The manufacturers of certain aircraft units impose storage limiting periods after which time they will not guarantee the efficient functioning of the equipment. On expiry of recommended storage periods the parts should be withdrawn from stores for checking or overhaul as recommended by the manufacturer. The effective storage

limiting periods of some equipment may be considerably reduced if suitable conditions of storage are not provided. Therefore, storage limiting periods quoted by manufacturers can only be applicable if the prescribed conditions of storage are in operation, and users should develop suitable limiting periods from their own experience.

2.6 **Flammable Materials**

All materials of a flammable nature, such as dope, thinners, paint, etc., should be kept in a store isolated from the main buildings. The precautions to be taken vary with the quantity and volatility of the materials, and such stores should comply with the requirements of HM Inspector of Factories and the Area Fire Authority.

2.7 **Segregation of Stock**

Care should be taken to segregate materials which may have deleterious effects on other materials, e.g. carboys of acid should not be placed in a store where escaping fumes may affect raw materials or finished parts; phenolic plastics should be segregated from cadmium-plated steel parts to prevent corrosion of the steel parts; magnesium alloys should not be stored in the vicinity of flammable materials.

2.8 **Packaging of Stock**

Stock should normally be packaged from the following:

- a) **Materials.** Plastics film, 'Jiffy' bags, lanolin grease impregnated cloth, plastics film lined paper envelopes, etc.
- b) **Methods.** Oiling and placing in jars or plastics bags, individual packaging of seals, etc.

NOTE: Magnesium fittings should not normally be kept in sacks, as the materials used in making the sacks may cause corrosion of the fittings.

2.9 **Materials in Long Lengths**

It is particularly important that long lengths of material, such as extrusions, tubes, bars, etc., should generally be stored vertically, which tends to reduce problems caused by bow and handling damage. Care should also be taken when placing the material in the storage racks to prevent indentations and scratches, especially when handling the high strength aluminium alloys.

3 **Storage Conditions For Specific Materials and Parts**

This paragraph gives guidance on recommended methods of storage for various materials and parts.

3.1 **Ball and Roller Bearings**

Ball and roller bearings should be stored in their original wrappings in dry, clean conditions with sufficient heating to prevent condensation caused by significant temperature changes.

- 3.1.1 If the wrapping has become damaged or if it is removed for inspection of the bearings, the bearing (providing it does not incorporate rubber seals) should be soaked and swilled in white spirit to remove storage grease and/or dirt. It is permissible to oscillate or turn the races slowly to ensure thorough cleaning, but the bearings should not be spun in this unlubricated condition because the working surfaces may become damaged. A forced jet of white spirit may be used to advantage but an efficient filter should be provided in the cleaning system.

- 3.1.2 In certain cases it may be preferable to clean very small bearings with benzene, but if this fluid is used, consideration should be given to the fire hazard and possible toxic effects.

- NOTES:**
- 1) There are certain proprietary light white spirits which are suitable for use with very small bearings and which eliminate some of the dangers associated with the use of benzene.
 - 2) Miniature steel balls and special high precision balls are immersed in instrument oil contained in plastic phials with screw-on caps.

- 3.1.3 After cleaning, the bearings should be inspected for signs of corrosion and then re-protected with a compound of mineral oil and lanolin and wrapped in greaseproof paper. Many miniature bearings, especially those used in instruments, are susceptible to brinelling. When such bearings have become suspect or contaminated they should be discarded.

NOTE: In many instances orders for bearings are endorsed with a requirement that special grease should be applied by the manufacturer. If this grease is removed for any reason, it is essential that grease of the correct specification is re-applied.

3.2 Aircraft Batteries

3.2.1 Lead-Acid Batteries

A charged battery which is to be stored for any length of time should be in the "fully charged" condition. Before storing, the electrolyte levels should be checked and the battery bench-charged in accordance with manufacturer's instructions. When fully charged, the battery should be stored in a cool, dry, well ventilated store on an acid-resistant tray. Batteries may also be stored in the dry, uncharged state. Additional points to note are as follows:

- a) Every 4 to 6 weeks (depending on manufacturer's instructions) the battery should be removed from storage and fully recharged, i.e. until voltage and specific gravity readings cease to rise.

NOTE: Damage to the battery will occur if it is allowed to stand idle beyond the period for charging specified by the manufacturer.

- b) Regardless of periodic check charges, the battery should be given a complete charge and capacity check immediately before being put into service.
- c) For new batteries, a complete capacity test to the manufacturer's instructions should be made every 6 months, but if the battery has been in service this test should be made every 3 months.
- d) Every 12 months, or earlier if a leak is suspected, an insulation resistance test should be carried out to the manufacturer's instructions.
- e) If the conditions mentioned in the previous paragraphs are observed, a battery may remain in storage up to 18 months. A battery should not be allowed to stand in a discharged condition, and electrolyte temperatures should not exceed 48.8°C.

NOTE: Trickle charging at low rates is not recommended as damage will occur if idle batteries are subjected to this form of charging.

3.2.2 Silver-Zinc Batteries and Silver-Cadmium Batteries

These batteries should be stored in clean, dry, cool and well ventilated surrounds, not exposed to direct sunlight or stored near radiators.

- a) New batteries will normally be supplied in the dry condition with the electrolyte contained in polythene ampoules. If possible, new batteries should be stored in their original packaging together with the related ampoules of electrolyte. For storage periods of more than 2 years, special instructions should be requested from the manufacturers.
- b) Filled and formed batteries required for use at very short notice may be stored in the charged condition. Manufacturers normally recommend that such batteries should be discharged and recharged every 4 to 6 weeks. The manufacturer's schedule of maintenance should be applied to batteries stored in the charged condition.
- c) Batteries to be stored out of use for protracted periods, should be discharged at the 40-hour rate until the voltage level measured while discharging, falls below the equivalent of 0.8 volt per cell.
- d) Before storing batteries, the electrolyte level should be adjusted to near the maximum specified by topping up, using a potassium hydroxide solution of 1.300 sg.
- e) The need for care in handling potassium hydroxide, because of its caustic content, is stressed.

After topping up or filling, the top of the batteries should be cleaned and the connections and terminals lightly smeared with white petroleum jelly. In no circumstances should sulphuric acid or acid contaminated utensils be used in close proximity to silver-zinc or silver-cadmium batteries.

3.2.3 Nickel-Cadmium Batteries

This type of battery can be stored for long periods without damage, in any state of charge, provided the storage place is clean and dry and the battery is correctly filled.

- a) For the battery to be ready for use in the shortest possible time, it should be fully charged, correctly topped up and then discharged at normal rate for a period of 1 hour before storage.
- b) The battery should be cleaned and dried and the terminals and connectors lightly smeared with pure mineral jelly.
- c) The battery should be inspected at intervals of 6 to 9 months and topped up if necessary.
- d) Before going into service, the battery should be given a double charge and capacity check as recommended by the manufacturer of the particular type of battery.
- e) The battery should be stored on a shelf or rack, protected from dirt or dust, and where metallic objects such as bolts, hand-tools, etc., cannot drop onto the battery or touch the cell sides.

NOTE: The above refers to pocket plate nickel-cadmium cells and not to sintered plate nickel-cadmium cells, for which reference should be made to the manufacturer's instructions.

3.2.4 Precautions

It should be noted that sulphuric acid will destroy alkaline batteries; therefore, utensils which have been used for this acid should not be used with such batteries. It is also important to avoid any contamination from the fumes of lead-acid types of batteries. (See Leaflet 24-10).

3.3 Braided Rubber Cord

Braided rubber cord should be stored in a cool, dark place with an even temperature preferably not exceeding 18°C with relative humidity of approximately 65%. The cord should not come in contact with any radiant heat, grease, oil, water, organic solvents or corrosive materials.

NOTE: Storage at elevated temperatures may cause permanent deterioration of the rubber, and prolonged storage at low temperatures will cause temporary stiffening of the rubber.

3.3.1 Storage Limiting Period

Braided rubber cord has a storage limiting period of 4 years if stored in good conditions. Cord which has been issued from stores within the 4 year period from the date of manufacture may remain in service until the expiry of 5 years from that date.

- a) The date of manufacture of cordage can be determined by the colour of the threads in the cotton outer casing; French Blue 1986; Night Black 1987; Nato Green 1988; Service Brown 1989 and Canary Yellow 1990. After 1990 the colours are repeated in the same sequence for a further 5 years and subsequently until further notice.
- b) The number of coloured threads indicate the quarter of the year in which the cord was manufactured, e.g. one thread indicates the cord was made between 1st January and 31st March, two threads 1st April and 30th June inclusive.

NOTE: Further details are given in British Standard Specification (Aerospace Series) 2F 70 and 2F 71, Light Duty Braided Rubber Cord for Aeronautical Purposes.

3.4 Compressed Gas Cylinders

Stores which are used for storage of compressed gas cylinders should be well ventilated. The cylinders should not be exposed to the direct rays of the sun and no covering should be used which is in direct contact with the cylinders. Cylinders should not be laid on damp ground or exposed to any conditions liable to cause corrosion. Gas storage cylinders should normally be fitted with a transportation/storage cap over the shut-off valve to help prevent handling damage and contamination of parts which could cause a risk of explosion or fire. Portable gas cylinders (e.g. therapeutic oxygen, fire extinguishers) should be stored on racks and, where appropriate, control heads and gauges should be protected against impact.

- 3.4.1 No heating is required in stores where compressed gas cylinders are kept, unless specified by the manufacturer.
- 3.4.2 Lighting for stores containing combustible gas cylinders (i.e. acetylene) should be flameproof, or installed outside the building, lighting the interior through fixed windows.
- 3.4.3 Store rooms should be manufactured of fireproof materials and the cylinders so placed to be easily removable in the event of fire. The store should be at a distance from corrosive influences, e.g. battery charging rooms.
- 3.4.4 Full and empty cylinders should be stored in separate rooms, and appropriate notices displayed to prevent confusion.
- 3.4.5 Oxygen and combustible gases such as acetylene should not be stored together. Acetylene cylinders should be stored in the upright position.
- 3.4.6 Oxygen cylinders are generally rounded at the bottom, thereby making it unsafe to store in an upright position without suitable support. If cylinders are stacked horizontally special wedges should be used to prevent the cylinders rolling, and the stack of cylinders should not be more than four high.

3.4.7 Breathing oxygen and welding oxygen should be segregated and properly labelled to avoid confusion. In some cases welding oxygen may be used for testing oxygen components not installed in the aircraft, but welding oxygen should not be used in aircraft oxygen systems.

3.4.8 **Precautions**

If cylinders are exposed to heat, the gas pressure will increase and the cylinder walls may be weakened, causing a dangerous condition. Cylinders should be stored at some distance from sources of heat such as furnaces, stoves, boilers, radiators, etc.

- a) Oil or grease will ignite in the presence of oxygen, and if the latter is under pressure an explosion may result. Cylinders should be kept away from sources of contamination, such as oil barrels, overhead shafting, hydraulic components or any container or component that may contain oil or grease.
- b) Smoking, exposed lights or fires should not be allowed in any room where compressed gases are stored, and oily or greasy clothes or hands should be avoided when handling the cylinders.
- c) Grit, dirt, oil and water should be prevented from entering the cylinder valves.
- d) When returning any cylinder that may have been accidentally damaged or overheated, the supplier should be notified so that any necessary action may be taken before refilling.

3.5 **Electrical Cables**

Where electrical cables are stored in large reels it is necessary that the axis of the reels are in a horizontal position. If stored with the axis vertical there is a possibility that the cable in the lowest side of the reel will become crushed.

3.6 **Fabric**

Fabric and fabric covering materials (e.g. strips and thread) should be stored in dry conditions at a temperature of about 21°C away from direct sunlight. Discolouration, such as iron mould, is sufficient to cause rejection of the material and this may be caused by unsuitable storage conditions. Most synthetic fibre fabrics should be stored away from heat sources. Rubber proofed fabrics should be stored away from plasticised materials such as PVC as it is known, in some cases, for plasticisers to leach from some plastics and have an adverse affect on rubbers.

3.7 **Forgings, Castings and Extrusions**

All large forgings, castings and extrusions should be carefully and separately stored on racks to avoid superficial damage.

NOTE: The high strength aluminium alloys are susceptible to stress corrosion when in the solution treated condition, and it is important that parts so treated should be coated with a temporary protective such as lanolin.

3.7.1 Aluminium alloy forgings which are anodised normally need no protection in a heated store. Finished details should be protected in accordance with DEF STAN 03–2.

3.7.2 Aluminium alloy castings in store should not be contained in sacks or absorbent packages. It is not normally necessary to protect castings before machining, but finished details should be protected as for forgings in paragraph 3.7.1.

3.7.3 Aluminium alloy extrusions should be protected in store with a lanolin and mineral oil solution (DEF STAN 80–34) and as finished details with DEF STAN 03–2 as in paragraph 3.7.1.

3.8 Instruments

The smaller types of instruments are usually delivered in plastic envelopes and these should be used during storage to minimise the possible effects of condensation. The transit containers of the larger instruments contain bags of silica-gel (paragraph 2.2.3) to absorb moisture which may enter. The gel should be examined periodically, and if its colour has changed from blue to pink it should be removed, dried out and replaced, or renewed. It is essential that all instruments should be stored in a dry, even temperature, and that the storage limiting period recommended by the manufacturer is not exceeded.

NOTE: Whenever possible instruments should be kept in transit or similar cushioned containers until required for fitment to an aircraft.

- 3.8.1 In the absence of any specific recommendation by the manufacturer the storage limiting period for instruments should not exceed 3 years, and on completion of this time the item should be re-certified in accordance with the relevant Overhaul Manual. Additionally, any equipment containing gyro assemblies should be exercised and gyro wheels run for a period of 24 hours at the completion of periods not exceeding each 12 months of storage.

3.9 Oil Coolers and Radiators

Oil coolers and radiators are normally filled with an inhibiting fluid during storage; the fluid used should be in accordance with the manufacturer's instructions. The components should not be stored on the floor, but placed on raised wooden supports to permit a free circulation of air and minimise the possibility of damage to the matrices.

3.10 Paints and Dopes

For the storage of paint and related materials (i.e. all low flash point materials) it may be necessary to obtain a licence to comply with the requirements of the Petroleum Act. Paints should be kept in a dry store at a controlled temperature between 7° and 23°C.

- 3.10.1 Paint containers should be marked with the date of receipt so that the oldest batches may be used first, as pigments tend to 'settle out' when paint is stored. A simple method of avoiding settlement is to invert containers at regular intervals, e.g. once a month.

3.10.2 Toxicity of Solvents

If paints are handled or mixed in a confined space it is important to ensure adequate ventilation during such operations as the fumes from volatile liquids are harmful if inhaled in sufficient concentration.

NOTE: A point frequently overlooked in ventilating a paint store is that most solvents are heavier than air, so that ventilation is more efficient downwards than upwards.

- 3.10.3 Provided paints and dopes are suitably stored in their original sealed containers, the storage limiting period is normally 12 months in the United Kingdom, but this may vary elsewhere; for example, in tropical conditions the period is normally 6 months.

3.11 Pipes

Rigid pipes should be adequately supported during storage to prevent distortion. Flexible pipes should, unless otherwise stated by the manufacturer, be suitably wrapped, for example, in a sealed plastics sleeve before being stored in a darkened room, maintained at a temperature of approximately 15°C. In hot climates, flexible pipes should be stored in cool places where air circulates freely, since high temperatures tend to accelerate surface hardening of the outer cover.

- 3.11.1 Flexible pipes should be stored in a completely unstressed condition and, where possible, should be suspended vertically (see also paragraph 3.13.14).
- 3.11.2 The ends of all pipes should be blanked, using a type of blank which does not allow it to be left in position when the pipes are fitted. The use of rags or paper for this purpose is prohibited. The blanks should not be removed until just prior to fitting the pipe.
- 3.11.3 Chloride based materials, such as Neoprene and glass fibre tape should not be used for the wrapping of Stainless Steel and Titanium pipes. Chloride based materials break down with heat (temperatures above 150°C) to produce corrosive salts which will attack Stainless Steel and Titanium components resulting in premature failure. In addition it is also possible that smears of chloride material may be left on components which have been touched by PVC (Plasticised Polyvinyl Chloride) sheeting while covered over by, or packed in, such material.

3.12 **Pyrotechnics**

Pyrotechnics should be stored in a dry, well ventilated building and kept at constant room temperature. The building should conform to the local by-laws laid down by the Local Authority.

- 3.12.1 At the periods specified by the manufacturer, pyrotechnics should be examined for any signs of damp or other external damage.
- 3.12.2 With paper-cased items, such as signal cartridges, the effect of damp is usually indicated by softening or bulging of the outer case and evidence of staining.
- 3.12.3 With metal-cased items, the effects of damp may often be indicated by traces of corrosion or tarnishing of the case and/or staining of the instructions label.
- 3.12.4 All pyrotechnics gradually deteriorate in time, although such deterioration will vary with factors such as quality or type of composition, degree of protection afforded by the containers, etc. For this reason a proportion of the items should be proof-tested at regular intervals as specified by the manufacturer; the items will also have a maximum serviceable life, regardless of proof testing, which should not be exceeded.

NOTE: The most likely effect of storage deterioration is a loss of brightness and range.

3.13 **Rubber Parts and Components Containing Rubber**

The following storage conditions are generally acceptable for a wide range of components containing rubber in their manufacture or parts made of rubber. In many cases manufacturers make special recommendations and these should also be observed. (Further information can also be found in BS 3F 68 and 3F 69).

3.13.1 **Temperatures**

The storage temperature should be controlled between 10° and 21°C and sources of heat should be at least 3 feet from the stored article (unless screened) to minimise exposure to radiant heat. Some special rubber materials (e.g. neoprene) may withstand a wider range of temperature satisfactorily, i.e. –12° to 26°C, but before any rubber part is exposed to these temperatures the manufacturer's recommendations should be verified. This particularly applies to any special precautions necessary when thawing parts which have been subjected to the lower temperatures.

3.13.2 **Humidity**

The relative humidity in the store room should be about 75%. Very moist or very dry conditions should be avoided.

3.13.3 Light

Rubber parts should not be exposed to direct daylight or sunlight. Unless the articles are packed in opaque containers, store room windows or skylights should be screened or covered with a suitable transparent red or amber coating. Store rooms should be kept as dark as practicable. Use of artificial light which has a high ultra-violet level should be avoided.

3.13.4 Oxygen

Isolation from atmospheric oxygen greatly increases the storage limiting period of rubber parts. Where possible, parts should be packed in airtight containers or wrappings using talc or french chalk. Where parts are packed in airtight tins, the tins should be lined with wax paper or polythene to avoid direct contact with the metal.

3.13.5 Ozone

Exposure to air containing ozone even in minute quantities should be avoided.

Storage rooms should not contain any apparatus liable to generate ozone, such as high voltage electrical equipment, electric motors or other plant which may give rise to electrical sparks. Free access to outdoor air, which in temperate climates always contains ozone, should be avoided. Still indoor air is normally ozone-free because wall and ceiling coverings and organic materials rapidly destroy ozone.

3.13.6 Deformation

Rubber parts should be stored in a 'relaxed' position free from compression or distortion, with the least possible deformation. Deformation greatly aggravates the action of ozone and also leads to permanent changes in shape and dimensions. Articles received prepacked in a strain-free condition can, with advantage, be stored in their original packing, as long as they are clearly identified and labelled.

3.13.7 Contamination

Rubber parts should not come in contact with liquids or vapour concentrations during storage even though they may be subsequently used in contact with a similar fluid. Contact with copper, brass or corroded iron or steel, or with any compounds of manganese, should be avoided.

NOTE: If deterioration of seals is suspected, it can usually be verified by stretching the seals to 20% of their internal diameter. If cracks are visible under x10 magnification, the seals should be rejected.

3.13.8 Hydraulic and Pneumatic System Components

Hydraulic and pneumatic components generally have a nominal 7 year shelf life which may usually be extended for periods of 2 years by inspections.

NOTE: The maximum service life of seals is usually to be found in the approval Maintenance Schedule.

3.13.9 In many instances, hydraulic components are stored filled with hydraulic fluid which may leak slightly from the component; it is therefore important to ensure that fluid will not come into contact with other stored items.

3.13.10 If the stored component is filled with a fluid other than that used in the aircraft system (e.g. DTD 5540B is a hydraulic component storage fluid only) the component should be clearly labelled to ensure the removal of all traces of storage fluid prior to installation in the hydraulic system.

3.13.11 To avoid adhesion and to exercise the seals, it is in some cases recommended that the component be operated several times at three-monthly intervals. If the seals are square or rectangular, special care should be used in the initial operation as experience has shown that there is a tendency for seal stiction on its bearing surface and, if the part incorporating the seal is moved rapidly, the seal may tend to rotate and be damaged. This applies also where spring-loaded seals are concerned; growth of the rubber may result in damage to the sealing lip.

3.13.12 Tyres

Tyres should be stored vertically in special racks embodying support tubes, so that each tyre is supported at two points. Two-thirds of the tyre should be above the support tubes and one-third below. By this method the weight of the tyre is taken by the tread and distortion is reduced to a minimum. The tyres should be turned to a new position every 2 or 3 months. Where tyres are delivered in bituminised hessian wrappers, the wrappers should be left on during storage.

3.13.13 Inner Tubes

Inner tubes should be stored in the cartons in which they were received, but where this is not possible the tubes should be lightly inflated and stored inside covers of appropriate sizes to prevent damage. Tubes should not be secured in a fixed position (such as a tight roll) by rubber bands or tapes as this may cause the rubber to crack.

3.13.14 Storage of Rubber Hose and Hose Assemblies

Unless otherwise specified by the manufacturer, rubber hoses should be inspected and tested every 2 years; they should also be inspected and tested immediately prior to installation.

a) **Storage Conditions.** Hose and hose assemblies should be stored uncoiled and supported to relieve stresses. Air should circulate freely about the hoses unless they are contained in plastics envelopes. Temperatures in the store should be controlled as detailed in paragraph 3.13.1.

NOTE: Care should be taken to ensure that the plastics envelopes selected are compatible with the hose material, since some, including PVC, can have a deleterious effect on rubber.

b) **Sealing Blanks.** The correct sealing blanks should always be fitted to items in store. Plugs and caps conforming with AGS specifications are suitable but, where standard blanks cannot be fitted, the blanks used must be so designed that they cannot enter the pipe or be left in position when the assembly is coupled up. It is also important that the material used for blanking purposes will not 'pick-up' or leave small particles inside a coupling after long periods of storage. Tape, rag or paper should not be used.

c) **Bore Protection.** In some special cases, to prevent deterioration of the bore or inner lining of the hose, it may have to be stored filled with the liquid which it is intended to contain in service and instructions concerning this procedure are normally attached to the assembly. If a hose assembly is enclosed in an airtight plastics envelope, this should not be removed until the hose assembly is to be fitted. If this envelope becomes damaged during handling, it should be resealed or renewed after any desiccant inside has been checked for condition.

d) **Markings on Hose.** Various methods are employed to mark the date of manufacture on hoses. It is sometimes stencilled on the external surface, or impressed on a tab or band secured to the hose. In instances where the external surface is of cotton braid, some of the 'picks' are woven in black and some in colour which indicates the month and year of manufacture, as required by the appropriate Specification.

3.13.15 **Cleaning**

Any cleaning of rubber parts and components containing rubber, after storage, should be done with water, soap solution or methylated spirits. If synthetic detergents are used, care should be taken to select those that are not harmful to rubber. Petrol (or other petroleum spirit), benzene, turpentine, etc., should not be used, nor may cleaning be carried out with sharp or abrasive objects such as wire brushes or emery cloth. Disinfectants should not be used. After cleaning, articles should be rinsed in water and dried at a distance from any direct heat.

3.14 **Sheet, Bar and Tube Metal**

It is recommended that sheet material should be stored on edge in racks; care being necessary to prevent the bending of single sheets. Flat stacking is not recommended (unless suction pads are used to lift the sheets) since sheets are almost invariably slid from the stack, often resulting in detrimental scratches on the sheet removed and on the adjacent sheet. Where vertical storage is employed, the material should be kept clear of the floor to prevent possible damage by scraping, splashing from disinfectants used for floor cleaning (which may cause corrosion) and the possibility of edge corrosion, which can occur with light alloy materials when in contact with composition floors. Temporary protectives, such as grease, paper or plastics coating, should be left in position until the material is required for use. If the temporary protective becomes damaged or partially removed, it should be restored without delay, and a periodic inspection of stock should be made.

3.14.1 There may be some merit in storing the sheet material in the transit cases. After the initial checking of the sheets, the case should be closed to eliminate dust/dirt which can cause surface scratching during handling operations.

3.14.2 Metal bars should be stored in racks either horizontally or vertically, well supported along the length when stored horizontally to prevent bending under weight. Metal tubing is normally stored in racks, well supported, the smaller diameter tubing being wired along the length, in bundles, to prevent damage.

NOTE: Floor cleaning fluids containing chlorides should not be allowed to contact metallic materials, particularly austenetic steel as a brittle fracture may eventually result.

3.15 **Sparking Plugs**

The plugs should be treated with light oil or other suitable corrosion inhibitor. The inhibitor should not come into contact with the plug screen, but the electrode end of the plug may be filled with oil and then emptied prior to fitting the caps. Plugs receiving this treatment should be washed out with trichloroethylene or carbon tetrachloride before use. Protector caps should be screwed on both ends of the plugs to prevent the ingress of moisture or foreign matter. The plugs should be stored in a warm dry place, preferably in a heated cupboard, as an additional precaution against the ingress of moisture.

3.16 **Survival Equipment**

Survival equipment should be stored in a room which can be maintained at a temperature between 15° and 21°C, and which is free from strong light and any concentration of ozone.

3.16.1 **Preparation for Storage**

The manufacturer's instructions should be carefully followed when preparing survival equipment for storage. These instructions normally include: ensuring that the component is completely deflated; removing easily detachable components; fitting protection blanks or pads to inflation valves and other connections; dusting the component with french chalk and folding it loosely; wrapping in waterproof paper; and placing it on a shelf above the floor.

3.16.2 A tie-on label should be attached to the wrapping stating:

- a) The type, serial number and part number of the equipment;
- b) Date of inspection and inflation tests;
- c) Date of overhaul;
- d) Date of component overhaul;
- e) Date of next inspection and/or test.

NOTE: The components should be stored with the equipment but it is preferable that any CO₂ cylinders be fitted with a transit cap and stored separately.

3.16.3 Under no circumstances should life-jackets or liferafts be stored one on top of the other without a separation of corrugated paper or similar shock absorbing material.

- a) In the case of liferafts, not more than three should be stored on top of each other.
- b) In the case of life-jackets, up to ten may be stored on top of each other.
- c) Owing to the light texture of life-jackets, it is important that they should be handled with care to avoid damage.

3.16.4 **Storage Limiting Period**

The period is normally 6 months if packed and stored in accordance with the manufacturer's instructions. At the end of this period survival equipment should normally be:

- a) Opened up and inspected before further storage;
- b) Inspected, tested and overhauled prior to being operationally packed for stowage in aircraft.

3.16.5 Liferafts and life-jackets not operationally packed and placed in storage for more than 10 days after the last test should be re-tested before installation in an aircraft.

3.17 **Tanks (Flexible)**

The precautions to be taken during storage will depend on the type of tank and the packaging method (if any) used. Some manufacturers of flexible tanks specify that the tanks should be coated with a special preparation if they are to remain empty for more than 2 or 3 days, and that this preparation should be removed before the tanks are put into service.

3.17.1 Manufacturers also specify a 'long term' or 'short term' storage procedure contingent upon special requirements.

3.17.2 'Short term' storage is the period between transport of the tanks from the manufacturer's works and delivery for immediate installation by the aircraft firm.

3.17.3 'Long term' storage covers the period during which the tanks are held following receipt by the aircraft firm before installation, or shipment to locations at home or abroad, involving an extended period of storage prior to installation.

3.17.4 Flexible tanks can be divided into two categories for packaging and storage purposes:

- a) Tanks that can be folded, e.g. those not fitted with rigid internal members, heavy coverings or fittings which would preclude satisfactory folding.
- b) Tanks with heavy protective coverings, or fitted with rigid internal members, anti-surge valves, gauge units, etc.

3.17.5 **Folding and Packing**

When packing a tank for storage purposes it is important to fold it in such a way that no strain or creasing is imposed on the folded areas, and in many instances folding diagrams are provided. All openings should be sealed with the specified blanks and corrugated cardboard interposed between the folds.

- a) After folding, the tank should be encased in an airtight wrapping, such as a polythene bag, and sealed.
- b) The tank in its airtight envelope should then be placed in a cardboard box which should also be sealed.
- c) Flexible tanks which are unsuitable for folding because of internal or external fittings, etc., are often packed in an air-inflated state suitably supported in sealed cases. This method of packing is used only for short term storage. For long term storage of this type of tank, the manufacturer's instructions should be followed which will vary with the shape and type of tank concerned.

3.17.6 **Storage Conditions**

Generally, flexible tanks should be stored in the original airtight containers supplied by the manufacturer and if this is not possible a similar airtight storage container should be used. The manufacturer's instructions should be observed closely. The tanks should be stored in cool, dry, draught-proof conditions, at a temperature not exceeding 25°C and preferably below 15°C.

3.18 **Tanks (Rigid)**

Rigid tanks should be carefully cleaned and any moisture dried out before storage. All apertures should be sealed with closely-fitting blanks. A silica-gel cartridge attached to a blank and placed inside the tank assists in preventing internal condensation and subsequent corrosion.

3.19 **Timber**

Plywood panels should be stored flat, away from all sources of heat or damp. Other timber sections should be stacked with spacers between each section to permit the free circulation of air. The timber should be checked periodically for moisture content. (See Leaflet 51-30.)

3.20 **Transparent Acrylic Panels**

Acrylic sheets should be stored on edge, with the protective paper left in position as this will help to prevent particles of grit, etc., becoming embedded in the surfaces of the sheets. When this is not possible, the sheets should be stored on solid shelves, and soft packing, such as cotton wool, should be placed between each sheet. The pile of sheets should be kept to a minimum and not exceed 12 sheets.

3.20.1 Curved panels should be stored singly with their edges supported by stops to prevent 'spreading'. There are several proprietary lacquers available for the protection of acrylic panels and shapings during handling and storage, including those complying with specifications DTD 900/5592.

3.20.2 Protective paper may also be used and, to prevent deterioration of the adhesive between the protective paper and the sheet, store rooms should be well ventilated, cool and dry. The material should not be placed near steam pipes or radiators as hot conditions will cause the adhesive to harden and make the subsequent removal of the paper difficult.

3.20.3 Material in storage should not be exposed to strong sunlight, particularly when the light shines through a glass window. This could cause a 'lens' formation resulting in local overheating to the detriment of the material.

3.20.4 Acrylic materials should not be stored with certain other materials because of the adverse effects which may arise from the vapours given off. A typical list of these materials is as follows:

Acetone	Dopes
Ammonia Vapour	Ethyl Alcohol
Amyl Acetate	Glacial Acetic Acid
Aviation Gasoline	Methyl Alcohol
Aviation Turbine Fuel	Nicotine
Benzene	Rust Remover
Butyl Acetate	Skydrol 500, and similar (Phosphate Ester) fluids
Carbon Tetrachloride	Synthetic Finishes
Cellulose Paints	Thinners
Cresol	Trichloroethylene
Deoxidine Materials	

3.20.5 When sheets are handled or moved they should be lifted off (not drawn from) the adjacent sheet. The vulnerability of transparent plastics to surface damage by scratching and bruising should be impressed on all personnel handling the material.

3.21 **Windscreen Assemblies**

All types of windscreen panels should be carefully protected from scratches, abrasions or other damage as small scratches or abrasions may considerably weaken the panels and impair their optical qualities. The manufacturer's recommendations relating to packaging or protective wrapping for storage purposes should be carefully followed.

3.21.1 **Glass Panels and Windscreen Assemblies**

All types of glass panels should be carefully protected from scratches, abrasions or other external damage.

3.21.2 **Sandwich Type Windows**

Sandwich type windows should be stored vertically in dry conditions, each window having its own desiccant cartridge attached, which should be inspected and renewed at specified periods. Spare windows are usually despatched with desiccant cartridges attached and these should not be removed until the window is to be connected to the aircraft desiccation system.

- a) Windows in transit should be allowed to 'breathe', this being particularly important when windows are transported by air, as considerable atmospheric pressure variations may be encountered.
- b) In addition to desiccant breathing cartridges, some manufacturers build into each window airspace another desiccator which consists of small discs of activated alumina strung on wire and encased in a cylindrical fabric stocking. Normally the desiccator does not require renewing.

3.21.3 Electrically Heated Windscreens

Extreme care is necessary in handling and storing windscreens. It is generally recommended that windscreens are stored in the manufacturer's packing, which usually consists of protecting both surfaces with adhesive polythene, wrapping in acid-free paper and cellulose wadding and storing in reinforced cartons.

- a) The panels should be stored separately in their cartons on racks, away from any strong light at a controlled temperature of approximately 10° to 21°C in well ventilated conditions.
- b) It is important that during handling or storage the thick glass laminate is kept uppermost to prevent delamination and that the polythene film is not removed until the panel is fitted to the aircraft.

3.22 Wire Rope

Wire rope should be stored in dry, reasonably well ventilated and temperature controlled conditions to prevent condensation. Wire ropes should not be stored where they might be exposed to the corrosive influence of acid fumes, steam or other corrosive agents, and should never be placed on a stone or concrete floor.

- 3.22.1 Wire rope in store should be inspected periodically for signs of corrosion or other damage. Where a wire rope dressing has been used, this should be renewed when necessary.
- 3.22.2 Wire rope should be wound on a reel, the diameter of which will be specified by the manufacturer according to the size and type of rope (usually 40 to 50 times the diameter of the rope).
- 3.22.3 If reels are made locally, it is important that oak, chestnut or western red cedar are not used in their manufacture as these timbers may corrode the wire rope. The inside of the reel should be lined with waterproof paper.
- 3.22.4 When unwinding wire rope, a spindle should be placed through the centre of the reel and fixed so that the reel is free to rotate and the free end of the cable can be pulled out in direct line with the reel. The cable should not be unwound by paying off loose coils, or by pulling the wire away from a stationary reel laid on its side. When cut-off lengths of wire rope are hand coiled, the coils should be of a diameter not less than 50 times the diameter of the wire rope concerned, with a minimum of 152 mm (6 in) diameter. When hand coils are unwound, the coil should be rotated so that the wire rope is paid out in a straight line. If the wire rope forms a loop on itself, this indicates a localisation of turn and should be eliminated by taking the turn out and not by pulling straight.
- 3.22.5 Before cutting the cable to length, it should be bound either side of the proposed cut to prevent loss of tension from the woven strands.

INTENTIONALLY LEFT BLANK

Chapter E Identification Marking

Leaflet E-10 Identification Marking Processes for Aircraft Parts

1 Introduction

- 1.1 The purpose of this Leaflet is to provide general guidance and advice on processes for marking aircraft parts for the purpose of identification. The information given is not applicable to individual items of equipment such as radio equipment and instruments and does not override any instructions given on drawings. Guidance on the determination and position of identification marking of metallic materials is given in Leaflet E-20.
- 1.2 Schedule 3 of the Air Navigation Order prescribes that all registered aircraft must have a metal name plate fixed near the main entrance of the aircraft, upon which is stamped or engraved the nationality and registration marks and the registered owner's name and address. This metal plate must be fireproof so that there will be means of identification in the event of the aircraft being destroyed by fire. The CAA recommends the use of a stainless steel plate.
- 1.3 To obviate the need for the revision of this Leaflet when new issues of specifications referred to are published, the prefix or suffix indicating the issue number of the specification has been omitted.

2 Identification Markings

- 2.1 Identification markings consist basically of the drawing number, drawing issue number and the inspection acceptance stamp. With some parts further information is necessary, e.g. a batch number, a process symbol or reference number, a non-destructive examination symbol, an assembly drawing number, a serial number and a date. Organisations manufacturing parts should, therefore, have 'inhouse' procedures defining the form and method of part numbering and identification of details, parts and components, so as to ensure that suitable methods, related to the nature, material and form of the part, are consistently applied.
- 2.2 The procedures should recognise that the application of the inspection stamp alongside the part and issue number (being an identification that the part complies with the full requirements of the drawing) has to be permanently legible.
- 2.3 There may also be a need to mark other information on components progressively during manufacture, so as to indicate satisfactory completion of processes or tests. These markings, however, may not need to be legible on the item in the fully finished condition.
- 2.4 Company procedures should define the form of marking for inspection clearance of part-finished items in such a way as to ensure that such parts are not confused with finished parts.
- 2.5 Where the marking process indents the surface of the part, parts for non-destructive examination (such as radiography) should be marked prior to examination. Unless a

marking medium which will not damage the coating is used, parts should also be marked prior to the application of a protective treatment, e.g. anodising.

3 Marking Medium

3.1 The medium selected for marking a part must be based on such factors as the purpose of the part, material from which it is made and critical features such as fatigue and notch sensitivity. Marking should not be made on highly stressed areas, near edges or on sensitive surfaces which may be needed to seal or conjoin. Processes available include etching, engraving, embossing, grit blasting, stamping, transfers, adhesive labels, marking inks and the attachment of metal plates, clips or tags. The following sub-paragraphs give information on the application of the various processes.

3.2 Acid Etching

3.2.1 Acid etching is widely used for marking hardened or delicate steel parts. The etching fluid can be applied to the surface of the part either by a glass pen fitted with a rubber suction cap or by a rubber stamp. Alternatively, the surface of the part may be coated in a suitable substance, e.g. beeswax and the required markings cut into this, followed by the application of etching fluid.

3.2.2 Before etching operations are commenced, the surface of the metal should be thoroughly cleaned. Immediately after marking is completed, the part should be thoroughly washed, dried and protected from corrosion. Pens and stamps used for applying the etching fluid should not be used for any other purpose.

NOTE: During the etching process care should be taken to avoid contact of the etching fluid with hands or clothing.

3.2.3 A fluid often specified for etching steels, other than corrosion-resisting or nitrided steels, is of the following composition:

Selenious Acid	20 g
Copper Sulphate (Crystals)	10 g
Concentrated Nitric Acid	15 ml
Water	80 ml

NOTE: When the fluid is applied to polished surfaces, a black deposit of iron-copper selenite will result.

3.2.4 A fluid often specified for etching corrosion-resisting and nitrided steels is of the following composition:

Selenious Acid	20 g
Copper Sulphate (Crystals)	10 g
Nitric Acid	25 ml
Hydrochloric Acid	60 ml
Water	10 ml

- a) The grey surface film of nitrided steels should be removed in the area to be etched. With corrosion-resisting steels, the fumes from the fluid tend to stain the surface of the parts; therefore, only the area to be marked should be free from storage grease or other protective compound.
- b) The method of application of the fluid and the general precautions to be taken are similar to those given in paragraph 3.2.2. In addition, special care must be taken not to inhale the etching fluid fumes.

3.3 **Electro-Chemical Etching**

- 3.3.1 This method of marking is generally restricted to corrosion-resisting steels, aluminium and its alloys, titanium and its alloys and copper based alloys. This process utilises an electrolytic principle by which marks can be produced on metal surfaces by using an electrolyte in conjunction with a low-voltage, low-amperage current. The process is simple and easy to apply and in general has no significant effect on the strength of metal parts. The colour and depth of marking is directly related to the voltage and amperage, to the direction and duration of current flow and the electrolytic etching fluid used.
- 3.3.2 Equipment and materials should be checked at regular intervals by etching a test piece and measuring the depth of etched area. This depth should not normally exceed 0.025 mm (0.001 in). In addition, different types of metals require different etching fluids and the instructions given on the relevant drawing or process specifications should be closely followed. This method of marking cannot be used on non-conductive surfaces.
- 3.3.3 The equipment required for the electro-chemical process consists of an electrical power-unit with a means of output adjustment (which usually embodies an automatic timing control), stencils and electrical contact devices. The marks to be etched can be produced either on paper stencils by typing, by stylus or metal stamp, or on plastics stencils by an electronic process. Paper stencils have an approximate life of 200 impressions, whereas plastics stencils have an approximate life of 2,000 impressions. Electrical contact devices may take the form of a bench pad, marking control head, roller and various types of pen. Basically all contact devices provide a means of connecting the part to be marked to the power-unit via the stencil and a felt or cotton-wool pad impregnated with electrolytic etching fluid. The circuit is completed by the attachment of a ground pin which may be embodied in the electrical contact device, but which, in any case, must make a good electrical contact and be attached adjacent to the area which is to be marked.
- 3.3.4 Before etching is commenced the surface of the part should be thoroughly cleaned. The stencils should be in good condition and should be discarded if they are distorted or ruptured, or the mark becomes obliterated. Pad holders should be used with the same electrolytic etching fluid throughout their life and the pad should always be kept moist with electrolyte and renewed when discoloured. All electrical plugs, sockets and ground pins should be checked to ensure good electrical contact. After etching, the part must be neutralised by the application of a suitable agent and thoroughly washed and dried.
- 3.4 **Electrical Etching.** Etching by the use of an electrical pencil, employing either the constant contact or intermittent principle of operation, causes the material to be severely overheated locally and should not be used for the marking of aircraft parts.
- 3.5 **Vibro-Etch Engraving.** This is a vibro-percussive engraving process, also known as 'Vibro-Peen' or 'Vibro-Percussion'. Generally, an electrically or pneumatically operated hand tool with a vibrating stylus is used. Marking by this process avoids the local overheating caused by electrical etching and if lightly applied has little effect on the

fatigue life of the part. Nevertheless, careful supervision is necessary to control the depth of marking and to have strict control of tip radius. Its use in a highly stressed area is not recommended. Inspectors' personal identification letters and numbers should be encircled with a vibro-etched ring to distinguish them from part numbers, issue numbers or date codes.

3.6 **Machine Engraving.** In this process the identification marks are produced by a mechanically guided rotating cutter or grinder normally controlled via a pantograph. The mark dimensions are limited by the size of the cutter and the size of the pantograph used. This process is sometimes used for stressed parts of high-grade steels or high-grade aluminium alloys. The depth of the marks is normally kept to the minimum compatible with clarity. The cutter or grinder used must be rounded, so that sharp corners or cuts are not produced on the part. This method is also used for engraving information or instructions on placards and name plates.

3.7 **Embossing**

3.7.1 In this process, which is suitable for castings, forgings and mouldings, the identification markings are inherent in the mould or die and are produced as part of the manufacturing process. The marks may either be raised or depressed but should not be located on an area of the part which is subject to subsequent machining.

3.7.2 The embossing process is also suitable for application to polytetrafluoroethylene (PTFE) and plastics materials after manufacture of parts. In this case the identification marks are produced by application of controlled heat and pressure via the medium of a die so as to transfer pigment from specially prepared coloured foils onto the prepared area of the part. Colours should be selected to contrast with the background colour of the part.

3.8 **Grit Blasting.** In this process, marks are produced by applying a controlled jet of abrasive material, in conjunction with rubber or plastics stencils, to specific areas. This process may be employed with advantage in certain circumstances, e.g. marking transparent plastics and hard anodised surfaces. The type and grade of abrasive material, air pressure and period of application is normally specified on the drawing. The process is not suitable where contamination by the abrasive material can occur, e.g. parts containing ball, needle or roller bearings and hollow parts. The depth of marking produced by this process is slight and is, therefore, not suitable for parts to which a protective finish will subsequently be applied. This process is not normally permissible for magnesium alloy materials.

3.9 **Stamping**

3.9.1 In this process, steel stamps are used for marking and these can be applied either by mechanical means or by hand in accordance with the drawing instructions. There are various types of machine available for marking parts with steel stamps and it is quite usual for a machine to be specified for this operation, as it can be pre-set to control the depth of the impression.

3.9.2 The indentations resulting from this form of marking can, unless carefully controlled, have a serious effect on the strength of parts and may lead to a considerable reduction of resistance to fatigue. Normally steel stamps are not used on aluminium alloy sheet thinner than 20 s.w.g. or on high strength aluminium alloy parts, or parts made from steel with an ultimate tensile strength in excess of 850 MN/m² (55 tonf/in²).

3.9.3 When steel stamps are used, they should not be larger than is necessary for clarity and a type size of 1.58 mm (0.0625 in) or 2.38 mm (0.09375 in) is usually found to be satisfactory. The symbol should not embody sharp points and should be shaped to produce a depression of 'U' rather than 'V' form. The depth of the impression

produced should be kept to the minimum particularly when applied to parts fabricated from sheet material, the impression should not result in embossment of the reverse surface. Worn stamps should not be used, since the additional hammering necessary to obtain an impression may affect the characteristics of the material. During any stamping operation, the part should be adequately supported by a backing block which has a smooth surface.

- 3.10 **Transfers.** In this process, marks are produced by the application of a prepared wet transfer, bearing the required markings, on the surface of the part to be marked. When dry, the transfer backing is removed leaving a film of the marking which is finally coated with a protective varnish. It is essential that the area of the part to be marked is thoroughly cleaned before the application of the transfer. Transfer markings do not physically alter the surface of the part and are suitable for application after completion of protective treatment. In general, this method can only be regarded as semi-permanent and only recommended for the identification of assemblies.
- 3.11 **Adhesive Labels.** In this process, marks are produced by the application of a label consisting of a foil (backed with adhesive) on which the marks are impressed prior to its being attached to the part. Such labels are often used for the identification of highly stressed components and since the adhesive is unaffected by temperature and most fluids, they provide a permanent identification without any indentation of the part. Where difficulty is experienced in the adhesion of such labels or where metal labels without adhesive backing are used, the application of a suitable flexible adhesive is specified. The possibility of dissimilar metals in juxtaposition setting up corrosion should be borne in mind and in particular, aluminium or zinc labels should not be used on parts manufactured from nickel base alloys, unless they have been cadmium plated.
- 3.12 **Marking Inks.** Marking by means of a suitable ink applied by rubber stamps or stencil is often specified for marking timber, plastics, fabrics, or metal parts which can only be marked after the completion of a protective treatment. It is common practice, particularly with metal parts, to have the area to be marked first painted with a white primer onto which the marks are applied; the area then being protected with an environmentally suitable clear varnish. To avoid deterioration of some materials, as a result of chemical reaction from the ink, it is important that only the ink specified is used (for an example see paragraph 5.9).
- 3.13 **Metal Clips, Plates or Tags.** In general, marking of parts by the attachment of clips, plates or tags is used where the size, shape, finish or material of the part precludes the application of markings to the surface. Further information on metal clips, etc., and other special applications is given in paragraph 5.

4 Position of Markings

- 4.1 The position of the markings and the process to be employed, is usually indicated on the drawing. The location selected for application of markings should always be remote from bearing surfaces, edges, holes, bends, changes of section, narrow or highly stressed areas and surfaces which have been hardened for a specific purpose. Certain manufacturers standardise the marking medium to be used on various materials and issue this information to the workshops as an internal specification, usually by adding a code number on the drawing. Any mark signifying inspection approval should be applied adjacent to the identification markings.
- 4.2 All markings should, if possible, be grouped together and positioned where they will not be obliterated or concealed by subsequent machining or assembly.

- 4.3 When sheet metal parts are heat-treated prior to manipulation, it is usual, where steel stamping is permitted, to apply a cipher to the parts so that the particular heat treatment batch can be identified subsequently. The position of the cipher should be carefully selected before heat treatment and manipulation. If after manipulation the cipher appeared on a bend this would usually lead to rejection of the part.
- 4.4 There are several reasons why the marking of some parts is unpractical, amongst these being size, hardness and fragility. Typical examples are hardened steel springs, bolts of less than 6.35 mm (0.25 in) diameter, nuts of less than 9.52 mm (0.375 in) diameter, split pins and taper pins. In such instances, it is permissible to pack the parts in a suitable container, which should be sealed with the identification and inspection approval applied.
- 4.5 When individual parts are fabricated into assemblies, the appropriate assembly drawing number and drawing issue number should be applied, together with the inspection approval mark, in the manner and position indicated on the drawing.
- 4.6 Information on the application of serial numbers is given in paragraph 6.

5 Special Applications

- 5.1 Because of factors such as shape, material characteristics, etc., it is not always possible to mark all parts in the normal way. The following paragraphs give guidance on the marking of such items.
- 5.2 **Bolts.** Part numbers and inspection stamps should be marked on the flat portion of the head; marking of the shank is not permissible. With cold-headed bolts, the inspection stamp may be omitted, provided the bolts bear the maker's identification symbol and are packed in sealed containers bearing evidence of inspection approval.
- 5.3 **Cable Assemblies**
- 5.3.1 It is recommended that swaged-end cable assemblies should be marked on the swaged shank of the end fittings by a rolling process, but if the necessary equipment is not available, the markings should be applied by a vibro-etching process.
- 5.3.2 If identification tags are fitted on swaged-end cables, they would have to comply with a specification such as British Standard SP51-52 and should be fitted as shown in Figure 1 or, when fitted to cable ends without locking wire holes, in accordance with the approved cable assembly drawings. Tags not covered by a specification, or tags fitted in a manner other than as given above, are unacceptable.

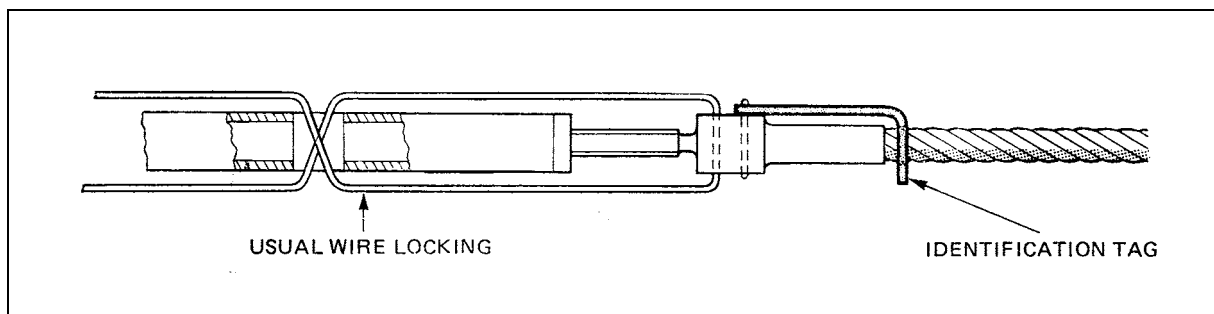

Figure 1 Cable Assembly Identification

- 5.3.3 Identification tags should be attached to spliced cables as shown in Figure 2. Where cast or pulley type thimbles are used, the identification marks can be applied direct to these items.

NOTE: If after the installation of a cable in an aircraft there appears to be any likelihood of the tag subsequently coming loose or causing jamming, it should be removed and the particulars on the tag should be entered in the aircraft log book or maintenance record.

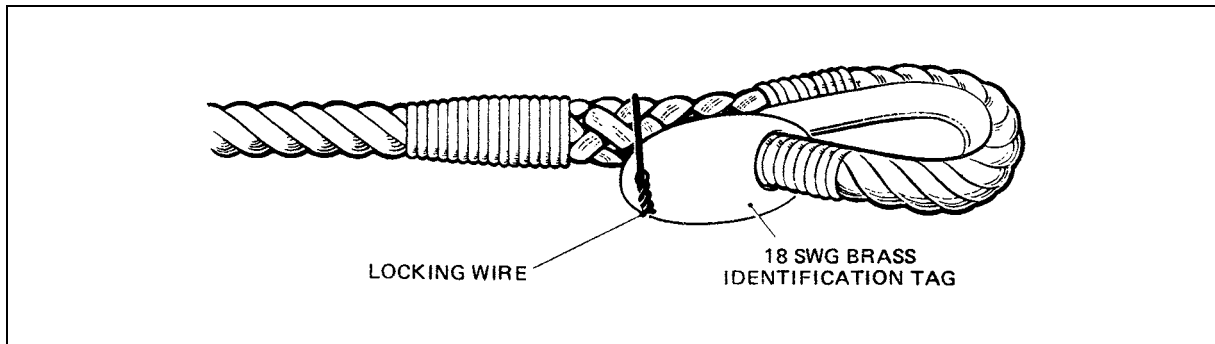

Figure 2 Method of Attaching Identification Tag to Spliced Cable

5.4 Castings

5.4.1 Castings should be marked, batched or tallied as soon as possible after removal from the mould, in a manner which will enable them to be correlated with the relevant mechanical tests and analytical records. The position of the marks should be in accordance with the relevant drawings, but if the position is not indicated on the drawing, thin sections liable to damage should be avoided and if possible, the markings should be placed where they will not be removed by subsequent manufacturing processes.

5.4.2 In many instances raised panels are produced as part of a casting especially for the application of identification marks; in which case the casting should not be marked in any other position.

5.4.3 Small castings from the same batch and for which the size is inconsistent with the display of part marking with adequate clarity may be packed in bags or bundles. The appropriate markings should however be stamped on a metal label securely attached to each bag or bundle.

5.5 **Nuts.** Where identification marks are necessary, i.e. on nuts of 9.52 mm (0.375 in) diameter or more, they should always be applied to the hexagonal sides of the nuts and in no circumstances to the mating surfaces, since this could result in the scoring of underlying metal when the nut is assembled.

5.6 Pipes

5.6.1 Pipes manufactured of material which may be soft soldered are usually marked by means of a brass plate bearing the appropriate data. The inspection stamp should be impressed on the plate just before it is assembled, but in instances where this procedure is unpractical, the stamp may be impressed in a blob of solder beside the plate. It is essential to ensure a complete soldered bond between the plate and the pipe, since flux residue may cause corrosion.

5.6.2 Where soldering is unpractical, pipes may be marked by electro-chemical etching, see paragraph 3.3, or by a rubber stamp using a non-corrosive dye, or by a specially made flexible slip-on sleeve. In some instances an adhesive label is used, but wrap-round or tie-on metal identification tags should not be used.

NOTE: Cases have occurred where metal identification tags have worn a pipe to paper thinness and in the course of time, have produced a pin hole leak under the tag.

5.6.3 Information on the identification marking of aircraft pipe systems is given in British Standard M23.

5.7 **Plastics**

5.7.1 The method of marking plastics parts depends on the thickness, shape and material of the part to be marked. With the majority of plastics produced by a moulding process, the identification markings are included in the moulding, but in the following paragraphs consideration is given to the marking of plastics produced by other processes.

5.7.2 **Glass-fibre Reinforced Plastics Laminates**

- a) On equipment subject to stress, vibro-etching should not be used because it can break strands and create stress raisers. In such cases the component should be marked with either white paint and indian ink, or a rubber stamp on a white painted surface.
- b) In instances where the weave pattern of the reinforcing cloth stands slightly proud of the surface, a rubber stamp and marking ink may be used. Before applying the mark it is essential that the release agent should be removed from the surface of the sheet in the area where it is to be marked. White spirit will remove most release agents, which differ according to the type of material, but it will not remove all traces of silicone. For most purposes, it is recommended that the area to be marked should be lightly rubbed with fine abrasive cloth.
- c) For non-stressed parts and if the laminate has a smooth surface, the use of a vibro-etching process is suitable. An ink or dye can be wiped over the etched surface so that the letters show more clearly.

5.7.3 **Thermo-plastics.** Thermo-plastics, such as cellulose derivatives and vinyl resins, are materials which can be made pliable by heat and which retain their original properties when cooled, it being possible to repeat the process any number of times without appreciable change in properties. All thermo-plastics, with the exception of certain forms of celluloid and vinyl acetates, can be marked satisfactorily with heated dies, but this method may not be suitable for tubular sections. However, the die temperatures vary with different materials and the recommended temperature should be ascertained from the manufacturer.

5.7.4 **Thermo-setting Plastics.** Thermo-setting plastics are materials in which a chemical reaction takes place while they are being moulded under heat and pressure. The chemical and physical properties of the material are entirely changed and it is subsequently resistant to further applications of heat. The heated die process is not suitable for materials in this group and for the majority of applications the vibro-etching method can be used, but where this may cause damage to the material, white paint and marking ink may be preferable.

5.7.5 **Transparent Plastics.** The marking of parts manufactured of transparent plastics materials should be avoided where possible. If the material is bonded permanently to a metal frame it is preferable to apply the marking to the metal portion. However, if it is necessary to apply identification markings to transparent plastics, these should be applied to the inner face of the panel by means of mild sandblasting and stencil. When it is necessary to mark a part temporarily, a label should be affixed by means of masking tape but labels should not be stuck directly to the material. When parts are annealed by the process prescribed in specification DTD 925, this should be indicated by marking the part in the manner described above, with the legend 'DTD 925', followed by the date.

5.8 Propellers

5.8.1 In the case of wooden propellers, it is usual to apply steel identification stamps on the rounded portion of the boss, so positioned that the markings will not be obscured by the engine hub or the spinner. Inspection stamps are usually applied to indicate approval of the various stages of inspection, i.e. timber and cementing, inspection in the white and final inspection.

5.8.2 In the case of metal propellers, identification marks may be applied by using a suitable acid etching process. It is essential however, that careful control of this process be exercised to avoid weakening the metal or setting up stress raisers as a result of etching to an excessive depth.

5.9 **Radiators and Oil Coolers.** With the exception of components manufactured of light alloy, the identification marking should be stamped on a brass plate soft soldered to the casing adjacent to the inlet neck. Inspection approval is usually indicated by the application of a metal stamp in a blob of solder adjacent to the plate.

5.10 Rescue Equipment

5.10.1 Rescue equipment such as dinghies and life jackets should be marked with the manufacturer's identification symbol, the date of manufacture, the serial number and an inspection stamp. The marking medium used should have no deleterious effect on the fabrics to which they are applied. An ink containing phenol should not be used on nylon and an ink containing copper should not be used on rubber fabric as it would cause considerable damage after ageing and exposure to the air.

5.10.2 A record should be maintained by the manufacturer by which the serial number of each component can be correlated with the roll numbers of the fabric from which it was made and also with the batch number of such items as valves, CO₂ cylinders and webbing.

5.10.3 When rescue equipment components are repaired, inspection approval should be signified by the application of an inspection stamp and the date of that repair along with the part number for that component, on a record label attached to the component. Where overhauls or inspections are completed in accordance with the time/life requirements of an approved Maintenance Schedule, it is recommended that the date when the next inspection or overhaul is due is also entered on the record label.

5.11 **Tanks.** Tanks manufactured of light alloy material not provided with a metal data plate should be marked by coloured paint or ink on a white paint background. A rubber inspection stamp should be used and when the markings are complete, they should be protected by a coat of clear varnish.

5.12 **Timber.** All timber parts should be marked with a rubber stamp and ink and should be date stamped to enable the age of the part to be subsequently ascertained.

5.13 Tubes and Tubular Structures

5.13.1 Difficulty is sometimes experienced with marking steel tubes. A steel or brass plate applied in a manner similar to that described in paragraph 5.9 is sometimes used, but it should be noted that soldering H.T. steel tubes can adversely affect the fatigue resistance. In some instances a rubber stamping procedure is used. This consists of applying a rubber stamp, using a suitable ink, to a white paint background and then protecting the markings with a specified clear varnish. Adhesive labels are also often used.

- 5.13.2 In instances where the diameter of the tube is sufficiently large and at least one end is open, the markings may be applied around the circumference of the tube near one end, while the tube is supported internally by means of a suitable mandrel.
- 5.13.3 If the structure is to be painted, the identification markings should be temporarily masked until painting is complete.

6 Serial Numbers

- 6.1 Company procedures should be raised to cover the allocation and control of serial numbers, so that traceability to assembly, test and overhaul records can be achieved. Additionally, it provides a reliable reference for general recording purposes.
- 6.2 Where possible, serial numbers should be prefixed by a combination of letters which enables the manufacturer to be identified. In the majority of instances they should be identical to those used on the firm's inspection stamps. Where components are being produced by a sub-contractor, the serial numbers may be allotted either by the main contractor or the sub-contractor, but in no circumstances should the same combination of symbols and serial numbers be used by the main and sub-contractors for identical components.
- 6.3 Where possible, the serial number of the item, together with the drawing number and issue number of the drawing and the date of inspection, should be stamped on a plate similar to that illustrated in Figure 3. The plate should be manufactured of a material compatible with the component and should be attached to the component using a jointing compound to prevent corrosion. Where a plate cannot be used, the data should be painted on the component and protected with a coat of clear varnish.

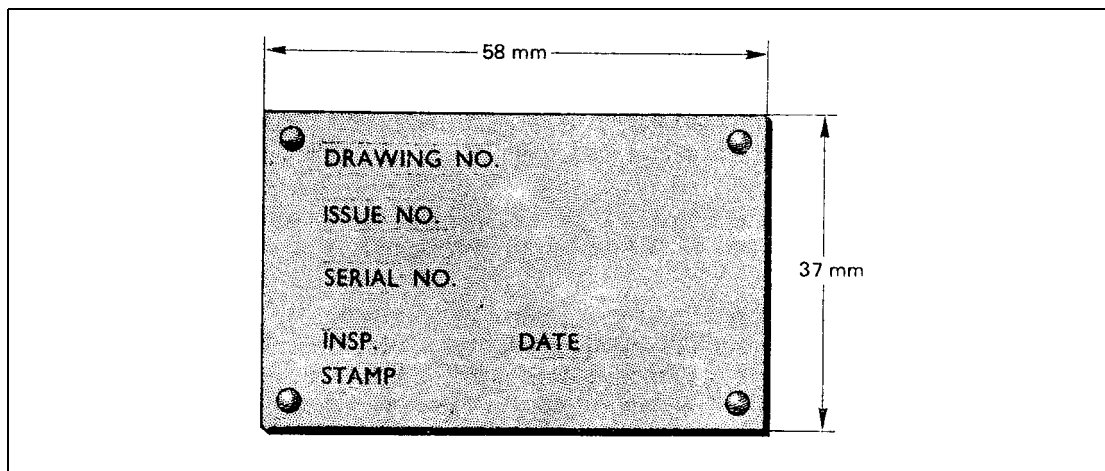

Figure 3 Identification Plate

- 6.4 Wherever possible, the serial number should be so positioned that it can be seen when the component is installed in the aircraft or on the engine; on certain components, the provision of a window, or a rip-off patch, may be necessary to achieve this.
- 6.5 The markings on the plate should be legible and not obliterated by paint, etc. During overhaul the plate should be checked for security since, should the plate be lost, difficulty may be experienced in proving the identity of the component and hence its state of serviceability. The identification plates of condemned components should be destroyed.

- 6.6 The serial numbers of fabric covered components are often reproduced externally on the fabric by stencils. Such markings are not necessarily permanent due to the periodical renewal of fabric and dope. Care is necessary to ensure that the markings correspond at all times with those displayed on the permanent plate.
- 6.7 Additional serial numbers must not be added to components by repair or overhaul organisations. When an area of a component bearing a serial number is renewed, or where extensive repairs are carried out, a copy of the original identification plate should be fitted, on which the letter 'R' should be placed after the serial number as a stroke number. The inspection stamp signifying approval of the repair and the date on which the repair was inspected should also be added.

7 Modifications

A record of modifications incorporated in a component should be listed on a modification record plate, so that the modification state of the component can be subsequently identified. Where possible, the plate should be positioned adjacent to the identification plate and should show the serial number and date of manufacture of the component with the modification numbers tabulated below. Where a plate cannot be used, the data should be painted on the component and protected with clear varnish.

INTENTIONALLY LEFT BLANK

Leaflet E-20 Identification Markings on Metallic Materials

1 Introduction

- 1.1 This Leaflet provides guidance and advice on the determination of type and positioning of markings on metallic materials, for the purpose of identification during manufacture. This Leaflet should be read in conjunction with Leaflet E-10 which gives information on the processes for identification marking of aircraft parts.
- 1.2 Chapter A1–4 of British Civil Airworthiness Requirements specifies that materials used in parts affected by airworthiness requirements shall comply with one of the following specifications:
- a) British Standard Aerospace Series Specifications.
 - b) DTD Specifications.
 - c) Specifications approved by the CAA.
 - d) Specifications prepared for a material in accordance with BCAR, Chapter D4–1 for large aeroplanes¹, by an Organisation approved for design where the material is to be used in a part designed within the terms of the design approval.
- 1.3 British Standards Aerospace Series and DTD specifications, make provision for the identification of materials by requiring the mark of the inspector and such other markings as may be necessary to ensure full identification. Manufacturers' Specifications (as in paragraph 1.2 d)) normally refer to the inspectional clauses of the relevant BS or DTD Specifications and consequently similar provision for identification is made.
- 1.4 To obviate the need for the revision of this Leaflet when new issues of specifications referred to are published, the prefix or suffix indicating the issue number of the specification has been omitted.

2 Method of Marking

- 2.1 Materials should be identified as early as possible in their manufacture.
- 2.2 The markings most appropriate for materials such as sheet, bar and castings are:
- a) Metallic stamp markings;
 - b) Markings produced by the die or mould used in shaping the material; and
 - c) Marking by rubber stamp, hand roller or printing machine.

Whichever method of marking is employed, damage to the material must be avoided and particular care should be taken when marking stressed parts of materials.

- 2.3 The markings most appropriate for parts and semi-finished materials are:
- a) Acid etching;
 - b) Electro-chemical methods;
 - c) Vibratory percussion;
 - d) Grit blasting; and

1. Chapters K4–1 for light aeroplanes, G4–1 for rotorcraft, C2–2 for engines.

- e) Deposition of iron-copper selenite.
- 2.4 Incised markings are not recommended for:
- a) Stressed parts where the impressions may act as stress raisers and originate cracks;
 - b) Materials and parts of thin section;
 - c) Materials or parts of such hardness, surface condition or shape that it is impracticable to apply a well defined marking;
 - d) Material ordered to exact sizes where no provision is made for the subsequent removal of the portion containing the incised markings.
- NOTE:** Electro-engraving of parts is prohibited and metallic stamp and vibratory percussion methods must not be used at highly stressed locations. If it is necessary to mark a part in a stressed region, etching or electro-chemical methods should be employed.
- 2.5 When metallic stamp marking is used, (as preferred for stock or random sizes of material) the marks have to be confined to a minimum area in a suitable position.
- 2.6 When marking with ink, enamel or paint is permitted, the marking medium has to meet the following criteria:
- a) It has to be permanent, except for 'non-immersion' markings used with some aluminium-based materials, where the marking is designed to disappear during solution treatment.
 - b) It has to have no corrosive or adverse effect on the material and be compatible with any material or substance with which it may subsequently be in contact.
- NOTE:** For stainless steels, the marking medium has to be free from organic compounds to obviate the possibility of carbon 'pick-up'.
- c) It has to remain legible when any protective process is applied to the material.
- 2.7 Where material is ordered to sizes which do not permit the identification markings being removed during production of a part, the purchaser may state expressly in his order that the material is to be used in the size as delivered and must not bear any incised markings. In such circumstances the material may be identified by:
- a) The pieces of material being bundled or parcelled and the marks required being stamped on a metal label securely attached to each bundle or parcel;
 - b) marking with paint, enamel or ink (see paragraph 2.6); or
 - c) one of the etching or electro-chemical methods.

3 Identification of Metallic Materials to Approved Specifications

- 3.1 The Procedure Specifications in the British Standards Aerospace Series, i.e. HC100, HR100, L100, L500, S100, S500, T100 and TA100, contain identification marking clauses which are applicable to all BS Aerospace Series and DTD Specifications for iron, nickel, copper and refractory base alloy castings, wrought heat resisting alloys, wrought aluminium and aluminium alloys, aluminium base and magnesium base ingots and castings, wrought magnesium alloys, wrought steels and wrought titanium and titanium alloys. New issues of approved specifications will include references to the identification clauses of the relevant specification.
- 3.2 The identification marking of metallic materials other than those covered in paragraph 3.1 is governed by the individual Approved Specification.

- 3.3 The identification markings should consist of the specification reference, the inspection stamp (except as indicated in paragraph 4) and such other markings as are necessary to enable the following details to be established:
- a) Manufacturer;
 - b) Cast number (where cast or cast/heat treatment batching is required by the Specification);
 - c) Batch number;
 - d) Test report number.
- 3.4 The identification mark of the inspector and the manufacturer's trade or identification mark may be combined in one symbol. Correlation between the relevant approved certificate and test report may conveniently be secured by marking the material with the test report number.
- 3.5 Additional markings such as those agreed by the supplier and purchaser and stated on the order or drawing may also be applied.

4 Identification of Material Forms

- 4.1 The identification markings which are generally applicable to various forms of material, ingots, castings, bars, sheets, etc., are given in this paragraph.
- 4.2 **Ingots.** Each ingot should be stamped with the marks indicated in paragraph 3.3, except that the inspection stamp may be omitted if the manufacturer's name or trade mark is cast on each ingot and the relevant inspection records are signed by the inspector accepting the ingots.
- 4.3 **Castings, Forgings and Stampings**
- 4.3.1 Each casting, forging and stamping which is large enough to be individually marked should bear the marks described in paragraph 3.3 and such other markings as may be stated on the order.
- 4.3.2 Marks, such as the part number and the manufacturer's name, may be incorporated in the die or mould used in shaping the part. Marks not so applied should be added by means of stamps unless some other method of marking is specified. All stamp markings must be placed where they have the least detrimental effect on the part; such position usually being indicated on the drawing.
- 4.3.3 Where forgings, stampings and precision castings approximate closely to the finished parts, the method of identification should follow the requirements for the marking of the finished parts, as shown on the drawing. Wherever practicable, compressor and turbine blade forgings should be individually identified, and this is of particular importance where the blade forgings are of similar shape and size and made from closely associated alloys, e.g. the alloys of the Nimonic series. Segregation and identification of stock, 'uses' and forgings for blades throughout the various production and heat treatment stages is necessary.
- 4.4 **Billets and Bars.** Each billet and bar, the diameter or width across flats of which is greater than 19 mm (0.75 in), should be stamped at one end with the markings detailed in paragraph 3.3.
- 4.5 **Sheets and Strips.** Each sheet and each coil or strip wider than 19 mm (0.75 in) should be stamped with the markings detailed in paragraph 3.3.

- 4.6 **Sections.** Each extruded and rolled section, the major sectional dimension of which exceeds 19 mm (0.75 in), should be stamped at one extreme end with the markings detailed in paragraph 3.3.
- 4.7 **Wire.** Each coil or bundle of wire should bear a metal label stamped with the markings detailed in paragraph 3.3 and such additional markings as may be required by the relevant specification (which may also require colour identification).
- 4.8 **Tubes.** Each tube, the diameter of which exceeds 25 mm (1 in), or in the case of light alloy and steel tubes exceeds 19 mm (0.75 in), should be stamped at one end with the markings detailed in paragraph 3.3 and with any additional markings required by the relevant specification.
- 4.9 **Items not Requiring Individual Identification.** As an alternative to individual identification, and provided that the material is from the same cast or batch:
- Ingots, small castings, forgings, stampings and bars, the diameter or width across flats of which does not exceed 6.5 mm (0.25 in);
 - Sheet and flat strips, the width of which does not exceed 19 mm (0.75 in);
 - Sections, the major sectional dimensions of which do not exceed 19 mm (0.75 in);
 - Tubes, the diameter of which does not exceed 25 mm (1 in), or in the case of light alloy and steel tubes does not exceed 19 mm (0.75 in);
- should be either wired together or packed in parcels, as appropriate. A metal label, stamped with the markings detailed in paragraph 3.3, should also be attached to each bundle or parcel.

5 Aluminium-based Materials

- 5.1 The identification marking requirements for aluminium-based materials are prescribed in British Standards L100 and L101, and castings, extruded bars, sections and sections rolled from strip, wire and tubes should, unless otherwise specified, be so identified.
- 5.2 **Ingots.** Ingots which have a sufficiently clean and smooth face to enable full legibility to be secured, may, at the discretion of the appropriately authorised person, be rubber stamped with the specification reference, preferably at each end of the ingot. The letters and figures should be not less than 13 mm (0.5 in) high and the ink used should comply with paragraph 2.6.
- 5.3 **Sheet and Strip in Coil Form**
- 5.3.1 In addition to the identification markings detailed in paragraph 3.3, sheet and strip may be required to be 'all-over' marked by the specification. Where strip is identified by ink markings, marking the material with the Specification reference may be omitted. 'All-over' marking should be carried out in accordance with the relevant clauses of BS L100 and as detailed in paragraphs 5.3.2 to 5.3.5, unless otherwise agreed between the manufacturer and the purchaser and stated on the order.
- 5.3.2 Each sheet and each strip in coil form, the width of which is 152 mm (6 in) or greater, should be marked in green ink with the Specification reference and the manufacturer's symbol in figures and letters 13 mm (0.5 in) high. The lines of markings should be at a pitch of 100 mm (4 in). The markings should be arranged in accordance with a) or b).
- The specification reference and the manufacturer's symbol should appear alternately and should be repeated at intervals of approximately 100 mm (4 in)

along each line of marking; the marks being so disposed that the Specification reference in one line is above the manufacturer's symbol in the line immediately below it.

b) The specification reference and manufacturer's symbol should appear on alternate lines, the marks in each line being repeated with a gap of approximately 25 mm (1 in) between them.

5.3.3 Each sheet and each strip in coil form, the width of which does not exceed 152 mm (6 in) (but not less than 50 mm (2 in) wide), should be marked as in 5.3.2 a) or b) at intervals of 100 mm (4 in) approximately along the centre line.

5.3.4 At the option of the manufacturer, each sheet and strip in coil form, the width of which does not exceed 50 mm (2 in) wide, can be 'all-over' marked, individually identified as detailed in paragraph 3.3, or, if from the same batch, bundled together with the required marks stamped on a metal label attached to each bundle.

5.3.5 Sheet and strip in coil form of material 26 s.w.g. and thinner, in the heat treatment condition stipulated by the specification and wide enough to be 'all-over' marked, may be hand marked in green ink along two lines only.

5.4 **Plate and Extrusions**

5.4.1 Plate, not included in the current issue of BS L100, should, unless otherwise specified, be marked in accordance with the relevant DTD Specification.

5.4.2 For plate fabrication and machining it is advantageous to know both the direction of rolling (not readily apparent with pieces cut to size) and the results of non-destructive testing. The user may require appropriate indications to be marked on each plate; such additional markings should be agreed between the purchaser and manufacturer and stated on the drawing or order.

5.4.3 Extrusions and plate which have been stretched in accordance with the specification or other conditions should be marked with the letters CS in a circle. Bars and sections should be marked at one end and plate should be marked alongside the specification reference. The marks should be made either by rubber stamp (blue or black ink) or by metal stamps, at the discretion of the material manufacturer.

NOTE: See also paragraph 5.6 when the contents of that paragraph are applicable.

5.5 **Forgings.** Forgings should, unless otherwise specified, be finally marked as required by BS L100. Where individual markings are required, L100 specifies that the drawing for the forgings should state the position at which the identification marks are to be applied; this is particularly important for forgings in high strength alloys.

NOTE: The method of applying the identification markings should be confirmed where it is not indicated on the drawing.

5.6 **Annealed, Not Aged, and as-Rolled Material**

5.6.1 Material released in other than the heat treatment condition stipulated by the specification should be marked in red by means of a transfer, paint or ink markings with the appropriate term to denote its condition and Approved Certificates covering such material should be clearly annotated "annealed", "not aged", etc., as appropriate.

5.6.2 For sheet and strip in coil form, the red markings in letters 13 mm (0.5 in) high should be repeated at intervals of approximately 101 mm (4 in) in lines midway between the lines of markings detailed in paragraph 5.3.3 and 5.3.4.

- 5.6.3 For extruded bars, sections and tubing, the red marking should be applied near one end of each length but, where lengths greater than 5 m (15 ft) are supplied, the markings should be applied at each end of each length.
- 5.6.4 For plate, the red marking should be placed near the specification reference or, where 'all-over' marking is required by the order, repeated at intervals midway between the lines of 'all-over' marking.
- 5.6.5 Material which is to be bundled and labelled should bear the appropriate wording stamped on the attached label.
- 5.6.6 The following terms are to be used, as appropriate:
- As Rolled.** To denote 'as-rolled' material.
 - Annealed.** To denote material in the softened condition.
 - Not Aged.** To denote material solution treated but which requires precipitation treatment.
- 5.6.7 The method of applying the red markings is left to the discretion of the manufacturer but the medium used should comply with paragraph 2.6.

6 Magnesium-Based Materials

Cast products should, unless otherwise specified, be identified in accordance with the requirements of BS L101. Wrought products should be identified as required to BS L500, the contents of paragraph 3.3 being taken into consideration. In general, the guidance given in previous paragraphs is applicable and the markings should be applied before chromate treatment.

7 Titanium-Based Materials

Titanium-based materials should be finally marked in accordance with BS TA100 and order requirements, the contents of paragraph 3.3 being taken into consideration. It is preferable not to use metallic stamping unless otherwise indicated on the order; billets, bars, sheet, etc., may be identified by rubber stamp markings. Where the cross-section is insufficient to enable full legibility to be secured, bars, rods, etc., from the same cast or batch and of the same nominal size may be wired together and the marks required may be stamped on a metal label attached to each bundle.

8 Ferrous Materials

Steel ingots and wrought products should, unless otherwise specified, be identified in accordance with the relevant procedure specifications, i.e. BS S100, S500 and T100; the identification marking requirements for steel castings are given in the relevant specifications.

NOTE: Leaded steels should be identified with a distinguishing mark 'L', 'LED' or 'LEADED' and the associated Approved Certificate should be appropriately endorsed.

9 Identification of Metallic Materials to other than Approved Specifications

Parts for general supplies (i.e. uncontrolled items as specified in Section A, Chapter A4–8 of British Civil Airworthiness Requirements) may be made from materials for which identification marking requirements are not specified. In such cases the appropriate person employed by the materials manufacturer should be guided by the terms of the order, but it is preferable that some form of marking be carried out by the manufacturer to correlate the material with its accompanying release documentation. It is essential, however, that the material is rendered identifiable after delivery to prevent any possible confusion with other material held by the purchaser.

INTENTIONALLY LEFT BLANK

Leaflet E-30 Bolts and Screws of British Manufacture

1 Introduction

- 1.1 The purpose of this Leaflet is to provide guidance on the identification of bolts and screws complying with British Standards 'A' Series of Aircraft Materials and Components and the Society of British Aerospace Companies 'AS' Series of specifications. The Leaflet does not include information on the Aircraft General Standards (AGS) Series since these have been entirely superseded by other standards. Information on the manufacture and testing of bolts and screws will be found in British Standards A100 and A101, entitled "General Requirements for Bolts and Nuts of Tensile Strength not exceeding 180 000 lbf/in² (125 hbar)", and "General Requirements for Titanium Bolts", respectively.
- 1.2 The identification of bolts and screws located on aircraft may not always be an easy task since not all are marked to show the standard to which they conform. This Leaflet sets out to show the features from which positive identification may be made, but it should be understood that items exist, which although identical in appearance, may not be interchangeable. It is also important to understand the direction of stress in a particular bolt since a 'shear' bolt must not be used to replace a 'tension' bolt. If any doubt exists as to the identity of a particular item the appropriate Parts Catalogue should be consulted; replacement of an incorrect part may lead to failure in service.
- 1.3 It will be found that a number of Specifications are either obsolete or obsolescent, in some instances due to the standardisation of a countersunk head of 100° included angle. The replacements are indicated in the tables.
- 1.4 A list of the abbreviations used in this Leaflet is in paragraph 5.

2 British Standards

- 2.1 This paragraph is concerned with the identification of bolts and screws complying with the British Standards 'Aircraft' (A) series. For ease of reference the paragraph has been divided into two sections, paragraph 2.2 dealing with bolts and screws having either British Association (BA) or British Standard Fine (BSF) threads, and paragraph 2.3 dealing with bolts and screws having Unified threads.

2.2 Bolts and Screws with BA or BSF Threads

- 2.2.1 In this series, BSF threads are used on bolts of ¼ inch diameter and larger; smaller bolts and all screws have BA threads, except that grub screws are also supplied in ¼ inch BSF. BA sizes larger than 2 BA are not specified. Table 1 gives a list of the relevant Standards, superseding Standards and identification data appropriate to the series, and Figure 1 illustrates the types of head used. To find the Standard number of a given item proceed as follows:

Identify the head from Figure 1, for example '(1)'. Reference to Table 1 shows that '(1)' refers to an A61 bolt. If the illustration applies to more than one specification, further information contained in the table, such as the type of finish, should enable the identification to be completed.

Table 1 BA and BSF Bolts and Screws

Standard No.	Description	Material	Finish	Head (fig.1)	Remarks	Thread	Normal Size Range
A17	Hex.hd.bolt	Al Al	anodic	e or f	obsolescent	BA/BSF	6 BA to 1 in BSF
A25	Hex.hd.bolt	HTS	cad	a,b,c or d	replaces A15Y	BA/BSF	6 BA to 1 in BSF
A26	Hex.hd.bolt	CRS	nat	a	replaces A15Z	BA/BSF	6 BA to 1 in BSF
A28	Hex.hd.bolt	Al Al	anodic	g or h	obsolescent	BA/BSF	6 BA to 1 in BSF
A30	Hex.hd.c/t bolt	HTS	cad	i or j	cad h & t	BA/BSF	6 BA to 1 in BSF
A31	Cheese hd. screw	LTS	cad	o	replaces AGS 247	BA	12 BA to 2BA
A32	Round hd.screw	LTS	cad	n	replaces AGS 245	BA	10 BA to 2BA
A33	90° csk. hd. screw	LTS	cad	q	replaces AGS 249	BA	12 BA to 2BA
A34	Raised csk.hd. screw	LTS	cad	p		BA	10 BA to 2BA
A35	Cheese hd. screw	CRS	nat	o	replaces AGS 896	BA	12 BA to 2BA
A36	Round hd.screw	CRS	nat	n	replaces AGS 967	BA	10 BA to 2BA
A37	90° csk. hd. screw	CRS	nat	q	replaces AGS 968	BA	12 BA to 2BA
A38	Raised csk.hd. screw	CRS	nat	p		BA	10 BA to 2BA
A39	Cheese hd. screw	Al Al	anodic	o		BA	12 BA to 2BA
A40	Round hd.screw	Al Al	anodic	n	replaces AGS 564	BA	10 BA to 2BA
A41	90° csk. hd. screw	Al Al	anodic	q		BA	12 BA to 2BA
A42	Raised csk.hd. screw	Al Al	anodic	p		BA	10 BA to 2BA
A43	Cheese hd. screw	Brass	tinned	o	replaces AGS 246	BA	12 BA to 2BA
A44	Round hd.screw	Brass	tinned	n	replaces AGS 244	BA	10 BA to 2BA
A45	90° csk. hd. screw	Brass	tinned	q	replaces AGS 248	BA	12 BA to 2BA
A46	Raised csk.hd. screw	Brass	tinned	p		BA	10 BA to 2BA
A55	Grub screw	FCS	cad	none		BA/BSF	6 BA to 1/4 BSF
A56	Grub screw	CRS	nat	none		BA/BSF	6 BA to 1/4 BSF
A57	Hex. hd. shear bolt	HTS	cad	k	cad h & t only	BSF	1/4 to 3/4 in BSF
A59	Hex.hd.c/t bolt	HTS	cad	i		BA/BSF	6 BA to 1 in BSF
A60	Hex. hd. shear bolt	HTS	cad	k		BSF	1/4 to 3/4 in BSF
A61	Hex.hd. bolt	Al Al	anodic	l or m	replaces A28	BA/BSF	6 BA to 1 in BSF

2.2.2 In some instances, e.g. A31 to A56 in Table 1, identification can only be effected from the finish applied (mechanical testing apart), or by the labelling on packages.

2.2.3 **Code Systems for Bolts.** The code system used for the identification of the bolts listed in Table 1 consists of the standard number followed by the part number of the particular bolt. The part number consists of a number indicating the nominal length of the plain portion of the shank in tenths of an inch, followed by a letter indicating the nominal diameter (Table 2). Example: The complete part reference number for an A57 bolt of 3.1 inches in length and 3/8 inch in diameter is; A57 31J.

Table 2 Diameter Code Letters

Code	Size	Code	Size
A	6BA	P	9/16 in BSF
B	4BA	Q	5/8 in BSF
C	2BA	S	3/4 in BSF
E	1/4 in BSF	U	7/8 in BSF
G	5/16 in BSF	W	1 in BSF
J	3/8 in BSF	X	12 BA
L	7/16 in BSF	Y	10 BA
N	1/2 in BSF	Z	8 BA

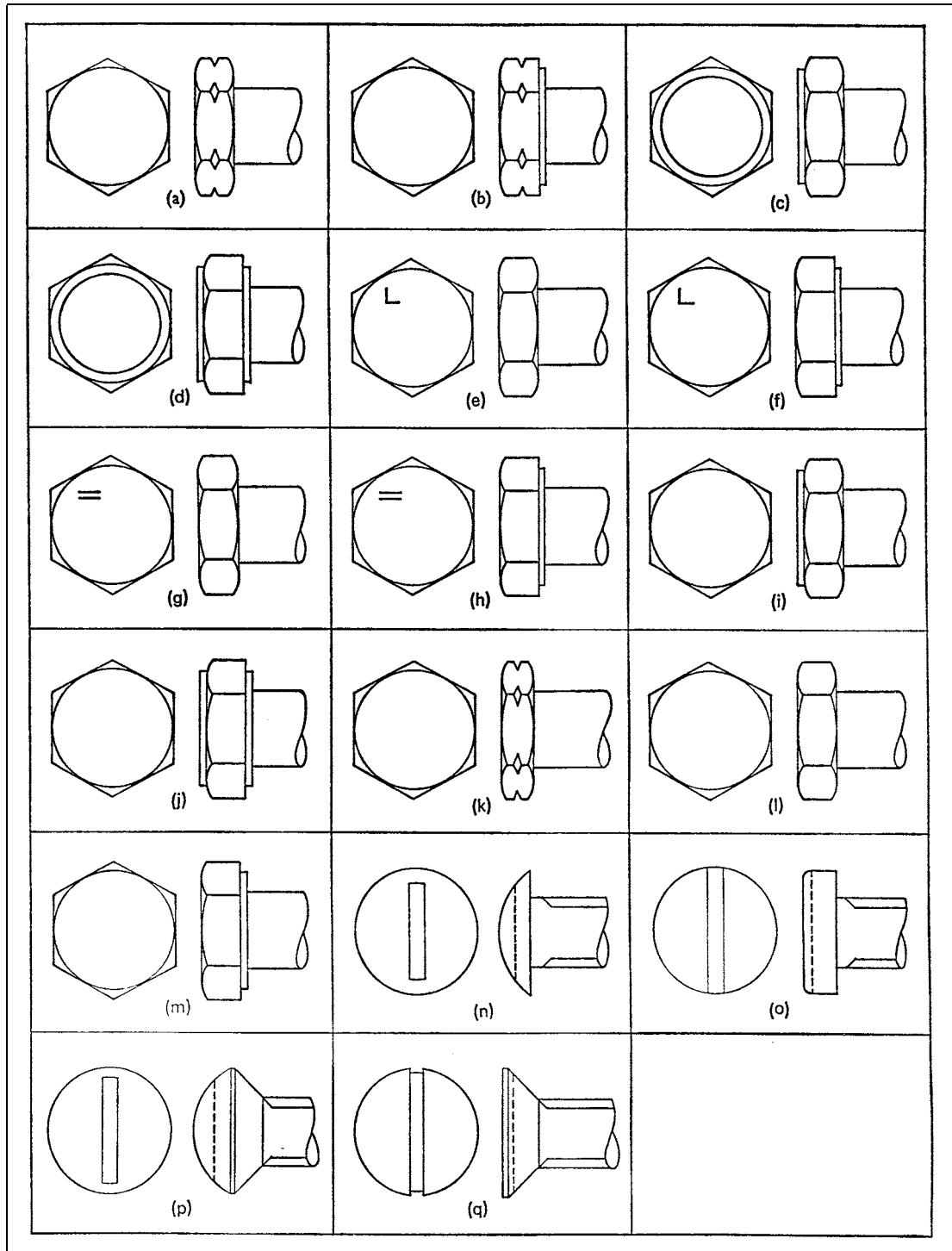

Figure 1 Identification of British Standards BA/BSF Bolts and Screws

- a) All bolts to British Standards A25, A26, A30, A57, A59, A60 and A61 of $\frac{1}{4}$ inch nominal diameter and over are marked with the appropriate British Standard on the upper face of the head. Additionally, bolts of $\frac{7}{16}$ inch nominal size and larger have the appropriate part number applied to the upper face of the head. Parcels of bolts have the number of the relevant British Standard and the appropriate part number clearly stated on the labels.
- b) The positions at which the plain length is measured on hexagon bolts and the overall lengths on various types of screws are indicated in Figure 2. It should be

noted that with BA and BSF bolts, the plain portion of the shank includes the thread 'run-out'. A 'washer face' (e.g. Figure 1 (b)) on the underside of a bolt head is not included in the plain length of the shank.

2.2.4 **Code System for Screws (A31 to A46).** The code system used for the identification of the screws listed in Table 1 consists of the British Standard number followed by the part number of the particular screw. The part number consists of a number indicating the nominal length of the screw (in thirty-seconds of an inch) when measured as described below (see also Figure 2) preceded by a letter indicating the nominal diameter (Table 2). Example: The complete part referencing number for a 2 BA A41 countersunk head aluminium alloy screw $\frac{1}{2}$ inch long, is A41 C16.

- Cheese and Round Heads.** The nominal length is the distance measured from the underside of the head to the extreme end of the shank, including any chamfer or radius.
- Countersunk Heads.** The nominal length is the distance measured from the upper surface of the head to the extreme end of the shank, including any chamfer or radius.
- Raised Countersunk Heads.** The nominal length is the distance measured from the upper surface of the head (excluding the raised portion) to the extreme end of the shank, including any chamfer or radius.

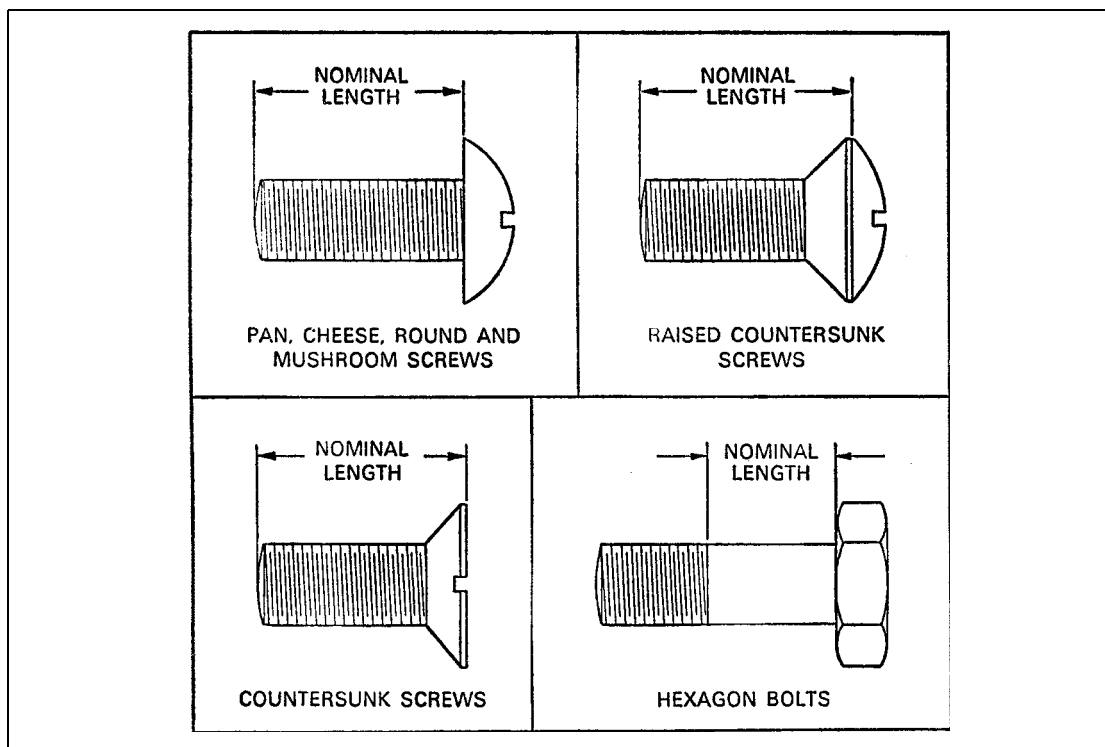

Figure 2 Length of BA/BSF Bolts and all Screws

2.2.5 **Code System for Grub Screws Complying with A55–A56.** The code system used for these screws consists of the British Standard number followed by the part number of the particular screw. The part number consists of a number indicating the overall length of the screw in sixteenths of an inch, preceded by a letter indicating the nominal diameter. Example: The complete part referencing number for a $\frac{1}{4}$ inch diameter A55 screw, $\frac{1}{2}$ inch long, would be A55 E8.

2.3 **Bolts and Screws Having Unified Threads**

- 2.3.1 Table 3 gives a list of current and obsolescent bolts and screws in the Unified range. Figure 3 illustrates the type of head used in this range and also shows the general 'Unified' symbols, including (h) the cylindrical extension (dog point) sometimes used on parts not having hexagon shaped heads. It will be noticed that there are several shapes of hexagon head; these are alternative methods of manufacture and do not necessarily provide a means of identification, although A108 and A111 bolts, which have close tolerance shanks, have a cylindrical extension on top of the head and shear bolts always have thin heads. Bolts and screws of similar shape may be further identified by the material; aluminium alloy is dyed green, high tensile steel is cadmium plated and corrosion resistant steel or brass are normally uncoated. When the British Standard number is not marked on the bolt head, identification should be made as follows.
- 2.3.2 Identify the head from Figure 3, for example (g). Reference to Table 3 shows that the bolt could be an A113, A114 or A170. Complete identification is possible in this example from the type of finish; in other instances it may be derived from further information, such as diameter or thread length, contained in Table 3

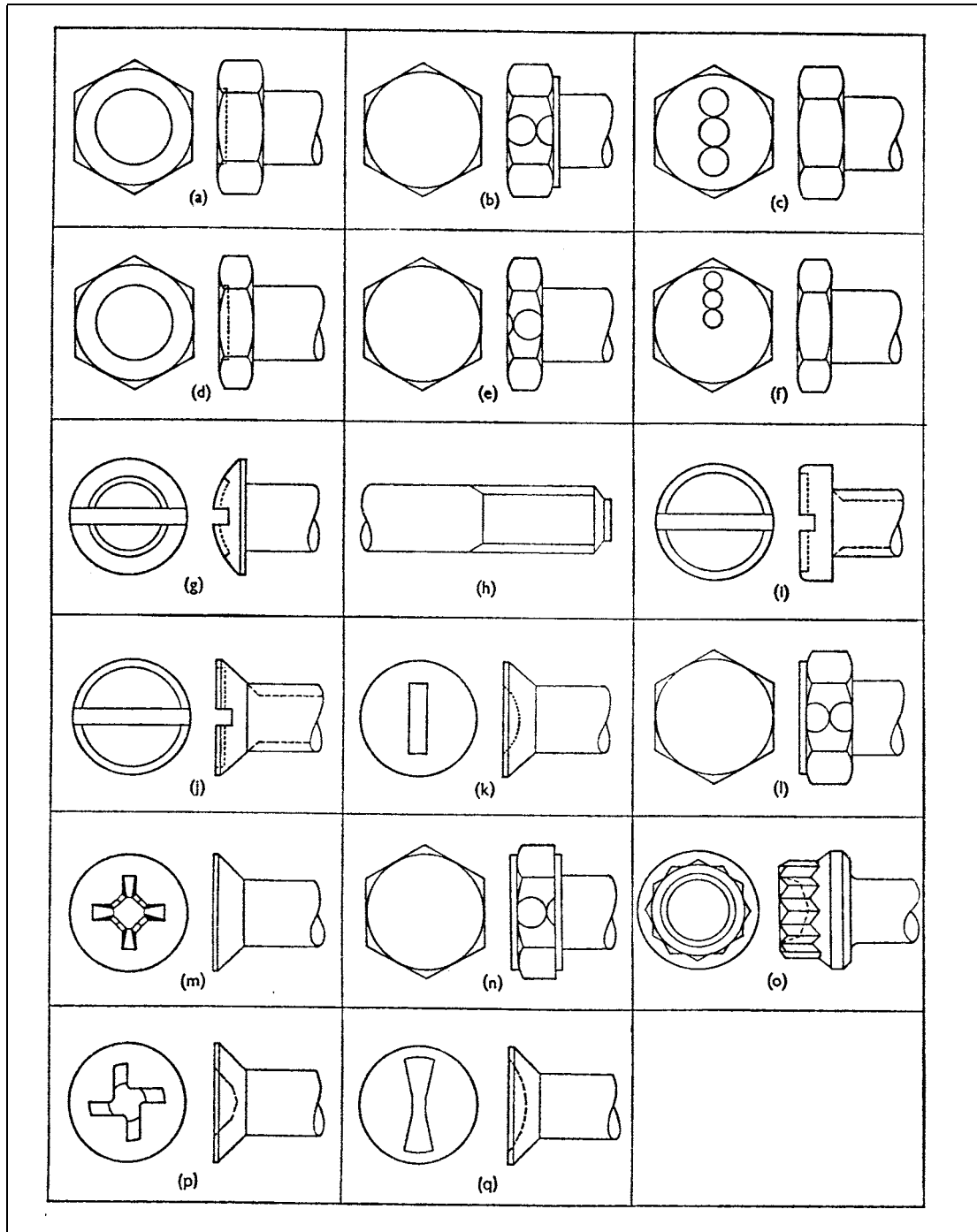

Figure 3 Identification of British Standards Unified Bolts and Screws

2.3.3 **Code System for Unified Bolts and Screws.** The code system used for the identification of the bolts and screws listed in Table 3 consists of the Standard number followed by the part number of the particular bolt. The diameter code shown in Table 4 is used on all parts but the measurement of length varies with different Standards as follows:-

- a) All bolts from A102 to A212 inclusive, nominal length in tenths of an inch followed by the diameter, e.g. an A102, 10–32 UNF bolt with plain length of one inch = A102–10D.

NOTE: Hexagon and mushroom head bolts are also supplied in lengths of 0.05 inch in some specifications, e.g. an A170— $\frac{1}{2}$ D bolt has a plain length of 0.05 inch.

b) All screws from A204 to A221 inclusive, diameter followed by length in thirty seconds of an inch, e.g. a 4—40 UNC A217 screw 1 inch long = A217—A32.

c) All bolts from A226 to A232 inclusive, diameter followed by nominal length in sixteenths of an inch, e.g. a $\frac{1}{4}$ inch UNJF A229 bolt with plain length of one inch = A229—E16.

NOTE: The position at which the nominal length of bolts is measured is shown in Figure 4; screws are measured as shown in Figure 2. It should be noted that the plain portion of the shank, on bolts with Unified threads, does not include the thread run-out.

Table 3 Unified Bolts and Screws

BS No.	Description	Material	Finish	Identification (fig.3)	Remarks	Thread and Class	Normal Size Range
A102	Hex.hd.bolt	HTS	cad	a,b or c		Unified, 2A	4-40 to 1 in
A104	Hex.hd.bolt	CRS	nat	a,b or c		Unified, 2A	4-40 to 1 in
A108	Hex.hd.bolt	HTS	cad	l or n	} cad hd. and thread only	Unified, 2A	10-32 to $\frac{1}{2}$ in
A109	Hex.hd. shear bolt	HTS	cad	d,e or f		Unified, 2A	$\frac{1}{4}$ to $\frac{3}{4}$ in
A111	Hex.hd.c/t bolt	HTS	cad	l or n		Unified, 2A	10-32 to $\frac{1}{2}$ in
A112	Hex.hd. shear bolt	HTS	cad	d,e or f		Unified, 2A	$\frac{1}{4}$ to $\frac{3}{4}$ in
A113	Mush. hd. bolt	HTS	cad	g, h		Unified, 2A	6-32 to $\frac{5}{16}$ in
A114	Mush. hd. bolt	CRS	nat	g, h		Unified, 2A	6-32 to $\frac{5}{16}$ in
A116	Pan. Hd. bolt	HTS	cad	i, h		Unified, 2A	4-40 to $\frac{5}{16}$ in
A117	Pan. hd. bolt	CRS	nat	i, h		Unified, 2A	4-40 to $\frac{5}{16}$ in
A119	90° csk. hd. bolt	HTS	cad	j	obsolescent	Unified, 2A	$\frac{1}{4}$ to $\frac{1}{2}$ in
A120	90° csk. hd. bolt	CRS	nat	j	obsolescent	Unified, 2A	$\frac{1}{4}$ to $\frac{1}{2}$ in
A169	Hex.hd.bolt	Al Al	green	b or c	replaces A106	Unified, 2A	6-32 to $\frac{5}{8}$ in
A170	Mush. hd. bolt	Al Al	green	g	replaces A115	Unified, 2A	6-32 to $\frac{5}{16}$ in
A171	Pan. hd. bolt	Al Al	green	i	replaces A118	Unified, 2A	4-40 to $\frac{5}{16}$ in
A172	90° csk. hd. bolt	Al Al	green	j, h	obsolescent	Unified, 2A	$\frac{1}{4}$ to $\frac{1}{2}$ in
A173	100° csk. hd. bolt	HTS	cad	k			8-32 to $\frac{1}{2}$ in
A174	100° csk. hd. bolt	CRS	nat	k		Unified, 2A	8-32 to $\frac{1}{2}$ in
A175	100° csk. hd. bolt	Al Al	green	k	replaces A172	Unified, 2A	8-32 to $\frac{1}{2}$ in
A204	100° csk. hd. screw	LTS	cad	j, h		Unified, 2A	0-80 to 10-32
A206	100° csk. hd. screw	CRS	nat	j, h		Unified, 2A	4-40 to 10-32
A208	100° csk. hd. screw	Al Al	green	j, h		Unified, 2A	4-40 to 10-32
A211	100° csk. hd. bolt	HTS	cad	m		Unified, 2A	8-32 to $\frac{1}{2}$ in
A212	Hex.hd.c/t bolt	HTS	cad	b or c	special quality	Unified, 3A	10-32 to $\frac{1}{2}$ in
A217	Pan. hd. screw	LTS	cad	i, h	replaces A205	Unified, 2A	0-80 to 10-32
A218	Pan. hd. screw	CRS	nat	i, h	replaces A207	Unified, 2A	4-40 to 10-32
A219	Pan. hd. screw	Al Al	green	i, h	replaces A209	Unified, 2A	4-40 to 10-32
A220	100° csk. hd. screw	Brass	tinned	j, h		Unified, 2A	0-80 to 10-32
A221	Pan. hd. screw	Brass	tinned	i, h		Unified, 2A	0-80 to 10-32
A226	Hex.hd.bolt	HTS	cad	a,b or c	short thread	Unified, 3A	4-40 to 10-32
A227	Pan. hd. bolt	HTS	cad	i, h	short thread	Unified, 3A	4-40 to 10-32
A228	Double hex. hd. c/t bolt	HTS	cad	o		UNJF, 3A	$\frac{1}{4}$ to 1 in
A229	Hex. hd. c/t bolt	HTS	cad	a,b or c		UNJF, 3A	10-32 to $\frac{1}{2}$ in
A230	Csk. hd. c/t bolt	HTS	cad	q		UNJF, 3A	10-32 to $\frac{1}{2}$ in
A232	Csk. hd. c/t bolt	HTS	cad	p		UNJF, 3A	10-32 to $\frac{1}{2}$ in

2.3.4 **Extent of Marking.** The markings actually applied to a bolt depend on the particular specification and whether marking is practical. Adding the code 'A217–Z32' to the

head of a 2–64 UNF pan head screw (head diameter 0.155 to 0.167 in), for example, would be very difficult, and having raised characters on a countersunk head bolt would, in certain circumstances, defeat the object of using that shape of head.

- a) **'Unified' Marking.** Most bolts, and screws 4–40 UNC and larger, are marked with a symbol to show that they have 'Unified' threads. The markings consist of contiguous circles (hexagon headed bolts only), a recessed head or shank dog point, and are illustrated in Figure 3.

NOTE: At some future date, to be agreed, the 'Unified' marking of screws will be discontinued and identification of these items will be solely from the label on the package.

- b) **Code Markings.** Most hexagon head bolts 10–32 UNF and larger are marked with the full code, i.e. Standard plus size code, but pan and mushroom head bolts may only be marked with the bolt length and countersunk head bolts are not usually marked at all. The code is not applied to screws, or bolts smaller than 10–32 UNF.

Table 4 Diameter Code Letters

Code	Size	Code	Size
Y	0-80 UNF	J	$\frac{3}{8}$ in UNF (UNJF)
Z	2-64 UNF	L	$\frac{7}{16}$ in UNF (UNJF)
A	4-40 UNC	N	$\frac{1}{2}$ in UNF (UNJF)
B	6-32 UNC	P	$\frac{9}{16}$ in UNF (UNJF)
C	8-32 UNC	Q	$\frac{5}{8}$ in UNF (UNJF)
D	10-32 UNF (UNJF)	S	$\frac{3}{4}$ in UNF (UNJF)
E	$\frac{1}{4}$ in UNF (UNJF)	U	$\frac{7}{8}$ in UNF (UNJF)
G	$\frac{5}{16}$ in UNF (UNJF)	W	1 in UNF (UNJF)

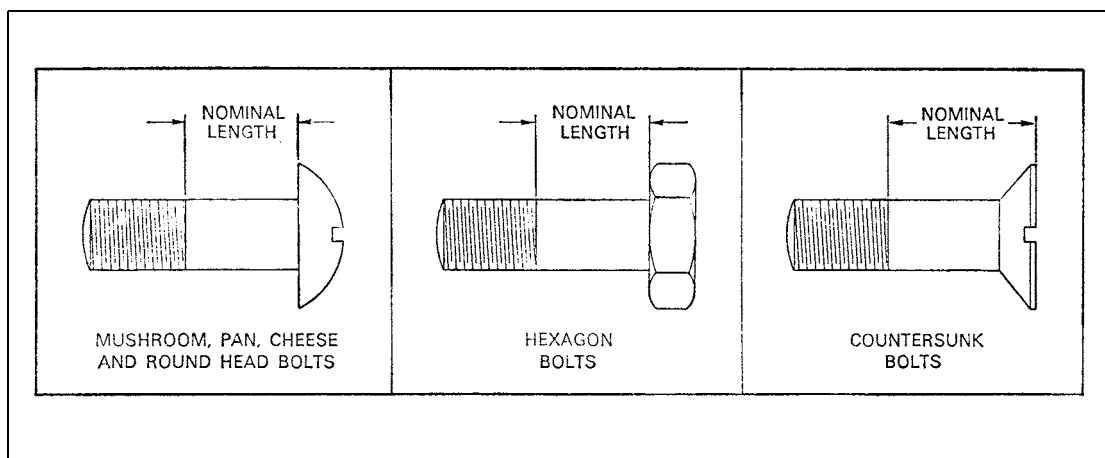

Figure 4 Length of BS Unified Bolts

3 'AS' Bolts and Screws

- 3.1 This paragraph is concerned with the identification of bolts and screws complying with the Society of British Aerospace Companies 'AS' series of specifications. The specifications provide a range of bolts and screws in sizes and head shapes not found

in British Standards specifications. Bolts manufactured from special materials (e.g. heat resistant steel) and having Unified threads are also included.

3.2 Table 5 shows the AS specifications for bolts and screws with BA/BSF threads, together with complete identification details.

Table 5 'AS' Numbers of BA/BSF Bolts and Screws







Head	Round	Mush-room	Raised Counter-sunk (90°)	Counter-sunk (90°)	Raised Counter-sunk (120°)	Counter-sunk (120°)	hexagon	Material	Finish
									
Bolts with screwdriver slot or hexagonal head	1247+	1249+	1245+	1243+				Al Al	Anodic
	4565	4566	4564	4563				Al Al	Blue
	1246	1248	1244+	1242			4569++	HTS	Cad.
	2922	2923	2921	2920				SS	Nat.
						2504++	HTS		Cad h & t
Bolts with Phillips recess	3078*+	3079*+						HTS	Cad.
	4597**	4598**	3295**	3294**	3296**	3297**		HTS	
Screws with Phillips recess	2991	2992	2994	2993	2995	2996		Mild Steel	Cad.
* 1 dot on head ** 2 dots on head								+ obsolescent ++ 2 BA only	

Table 6 'AS' Numbers of Round Head Bolts with Flat (Unified)

 Small head				 Large head			
10-32 UNF	1/4 UNF	5/16 UNF	3/8 UNF	10-32 UNF	1/4 UNF	5/16 UNF	3/8 UNF
6760 to 6804	6895 to 6939	7033 to 7077	7171 to 7215	6850 to 6894	6985 to 7032	7123 to 7170	7264 to 7308

3.3 Table 6 shows the AS specifications for 'round head' bolts with a locking flat and Unified threads. These bolts are manufactured from high tensile steel and are cadmium plated.

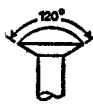
3.4 **Double Hexagon Head Bolts**

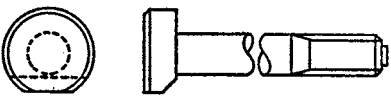
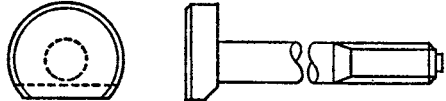
3.4.1 Table 7 shows the AS specifications for double hexagon head bolts manufactured from heat resistant steel and having UNS or UNJF threads. Requirements for protective treatment vary between specifications, some bolts being silver plated while others have a natural finish.

Table 7 'AS' Specifications

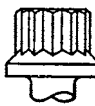
Thread	Type	Material	Head Shape	
				
UNS Threads (10-32 to 3/8-24 UNS-3A)	Plain	DTD 5066	13000 - 13399	17000 - 17399
		DTD 5026	13400 - 13799	17400 - 17799
		DTD 5077	13800 - 14199	17800 - 18199
	Externally Relieved Body	DTD 5066	14500 - 14899	18200 - 18599
		DTD 5026	14900 - 15299	18600 - 18999
		DTD 5077	15300 - 15699	19000 - 19399
	Close Tolerance Shank	DTD 5066	19400 - 19799	
		DTD 5026	19800 - 20199	
		DTD 5077	20200 - 20599	
UNJF Threads	Plain (8-36 to 3/8-24 UNJF)	DTD 5066	20800 - 21299	
		DTD 5026	21300 - 21799	
		DTD 5077	21800 - 22299	
	Close Tolerance Shank (10-32 to 3/8-24 UNJF)	DTD 5066	22400 - 22799	
		DTD 5026	22900 - 23299	
		DTD 5077	23400 - 23799	

NOTE: The UNS bolts listed in the table have reduced diameter threads for use in high temperature applications and should be fitted with nuts complying with specifications AS20620 to AS20639.

- 3.4.2 For purposes of standardisation a further series of heat resistant bolts with UNJF threads is being introduced to replace those with UNS threads. Details of the AS numbers allocated to these bolts are not, as yet, available, but the method of identification will be the same as described for the bolts in Table 7.
- 3.5 Table 8 shows the AS specifications for anchor bolts manufactured from weldable steel.
- 3.6 AS1 and AS2 are specifications for titanium bolts having Unified threads, with hexagon and 100° countersunk heads respectively. Both specifications are obsolescent but the bolts may be recognised by the material finish and the marking 'AS1' or 'AS2' on the head, as appropriate.

Table 8 'AS' Numbers of Anchor Bolts

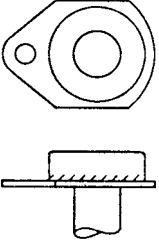
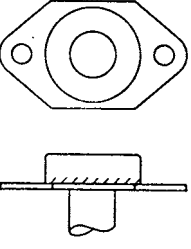
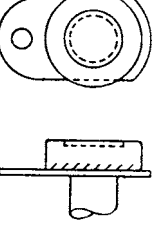
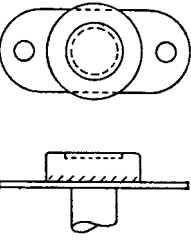
BA/BSF		Unified	
			
4752	4753	6735	6736
Weldable bolt is AS 4754		Weldable bolt is AS 6737	

3.7 **Identification Marking.** AS1, AS2 and all the bolts listed in Table 7 are marked with the AS specification to which they conform. Other AS bolts are unmarked except for the 'Unified' symbol which is applied to anchor bolts (recessed head) and the round head bolts shown in Table 6 (shank dog point).

3.8 Code System

3.8.1 Although a large number of AS bolts and screws are not marked in any way, codes are necessary for ordering and storage purposes.

3.8.2 The code system used for the identification of the bolts and screws listed in Tables 5 and 8, and for AS1 and AS2 bolts, is the same as that used for British Standards bolts, i.e. AS number followed by a number indicating length in tenths of an inch and a letter indicating diameter (Tables 2 or 4 as appropriate). The length is measured in the same way as for British Standard parts.

NOTE: AS2504 and 4569 bolts are only manufactured in 2 BA; the diameter code is therefore not required.

3.8.3 Reference to Table 6 shows that a batch of AS numbers is allocated to each diameter of bolt in this series. A separate number within each batch is reserved for a particular length of bolt so that a code system is unnecessary; any particular AS number in this series applies only to a bolt of specified length and diameter. The plain length is graduated in steps of 0.05 inch from 0.05 inch to 0.9 inch, and steps of 0.1 inch thereafter up to 3.4 inch. A 10–32 UNF bolt 1.2 inch long and having a small head will therefore be AS6780.

3.8.4 The bolts shown in Table 7 also have a batch of AS numbers allocated to each diameter but in this case the range of available lengths varies between specifications. The length of the bolt is taken as the whole length of the shank, including the thread in sixteenths of an inch up to 2 inches long, and eighths thereafter, each particular size having a unique reference number. It should be noted that this series of bolts has a threaded length greater than that normally found on aircraft fasteners. A minimum length of plain portion is also maintained, so that the thread length in the shorter bolts is reduced below the normal for the particular diameter.

4 Future Trends

4.1 Because of the importance of reducing weight in the manufacture of an aircraft, designers are constantly seeking means of using higher strength or lighter alloys for structural purposes. This trend applies particularly to fasteners and it is apparent that

the use of smaller diameter bolts and miniature anchor nuts will become more widespread. It will be accompanied by the use of threads of UNJF form.

- 4.2 In the field of light alloys, specifications for titanium bolts are being prepared and will probably be drawn up in accordance with existing American practice, within the framework of British Standard A101, entitled 'General Requirements for Titanium Bolts'.
- 4.3 Because of the vast experience gained, particularly in America, in the use of both standard and miniature components, it has been internationally agreed to use Unified inch threads on fasteners. However, with the introduction of metric dimensions in other fields, it is probable that a metric thread series will eventually be accepted.
- 4.4 As far as identification features are concerned it appears likely that the system used for recent specifications will continue; bolts in the AS series will be marked with a number which will be unique for a particular diameter and length, and bolts in the BS series will use the code at present applied to bolts with UNJF threads.

NOTE: There is no symbol used to differentiate between threads of standard unified or UNJ form.

5 Abbreviations

The following is an alphabetical list of abbreviations used in this Leaflet:

AGS	Aircraft General Standards
AS	Aircraft Standards
Al Al	Aluminium alloy
BA	British Association
blue	dyed blue over anodic film
BSF	British Standard Fine
cad.	cadmium plated all over
cad.h & t	cadmium plated head and thread only
csk.	countersunk
c/t	close tolerance
CRS	corrosion resisting steel
FCS	free-cutting steel
green	dyed green over anodic film
hd.	head
hex.	hexagon
HTS	high tensile steel
LTS	low tensile steel
mush.	mushroom
nat.	natural finish
SS	stainless steel
UNC	Unified coarse thread
UNF	Unified fine thread
UNS	Unified special thread
UNJF	Unified fatigue-resistant fine thread

Leaflet E-40 Standard Fasteners of American Manufacture

1 Introduction

This Leaflet provides guidance on the identification and coding of bolts, nuts, screws and washers which are manufactured to American National Standards and are used for general aircraft assembly. Many other types of American fasteners are used on aircraft, particularly in the field of light-weight, self-locking nuts and bolts, and these are approved for use by the relevant manufacturer or Airworthiness Authority; these fasteners will not necessarily be marked or identified in accordance with the national standards, but will comply with information published by the particular manufacturer.

2 Specifications

- 2.1 Standard aircraft fasteners in America are manufactured in accordance with Government, Military and Civil Specifications. The following series of specifications cover the materials, processes, and component drawings for all standard fasteners:

Federal Specifications

Society of Automotive Engineers Specifications (SAE)

Aeronautical Materials Division of SAE Specifications (AMS)

Air Force/Navy Specifications (AN)

Military Standards (MIL and MS)

National Aerospace Standards (NAS)

- 2.2 These specifications provide for a range of fasteners with Unified threads in the UNC, UNF and UNJF series. However, whereas for British aircraft, fasteners are manufactured in a selected range of Unified threads, American fasteners are, in some instances, supplied with both UNC and UNF threads. Extreme care is necessary when matching up nuts with screws or bolts in these series. If not properly identified, then thread gauges must be used to check the thread. Visual comparison of small threads is not recommended.
- 2.3 The various standards are dealt with separately in this Leaflet, and it should be noted that the AN series has to a large extent been replaced by MS and NAS components.

3 AN Fasteners

- 3.1 These specifications are in two series. The early series has numbers from 3 to 9000, with the fasteners occupying a range from 3 to 1000; these fasteners are of comparatively low strength, and are manufactured in steel or aluminium alloy. The steel parts are generally manufactured from low-alloy steel and if non-corrosion-resistant, are cadmium plated, whilst the aluminium parts are anodised. The later series parts have six figure numbers commencing with 100 000, are of more recent design and are generally manufactured from higher-strength materials.

3.2 Early Series AN Bolts

- 3.2.1 Table 1 gives a list of the early series AN Bolts, and Figure 1 shows the types of heads and the identification marking used to indicate the material from which the parts are made.

Table 1 Early Series AN Bolts

AN Number	Type	Material	Process	Nominal Range of Thread Sizes	Thread
3-20	Bolt, hexagon head	Steel	Cad.plated	No. 10 to 1 ¼ in	UNF
		CRS ¹	Nil		
		Al. alloy	Anodised		
21-36	Bolt, clevis	Steel	Cad.plated	No.6 to 1 in	UNF
42-49	Bolt, eye	Steel	Cad.plated	No.10 to 9/16 in	UNF
73-81	Bolt, hexagon, drilled head	Steel	Cad.plated	No.10 to ¾ in	UNF or UNC
173-186	Bolt, close-tolerance	Steel	Cad.plated thread and head	No. 10 to 1 in	UNF
		CRS ¹	Nil		
		Al. alloy	Anodised		

1. CRS = Corrosion-resistant steel.

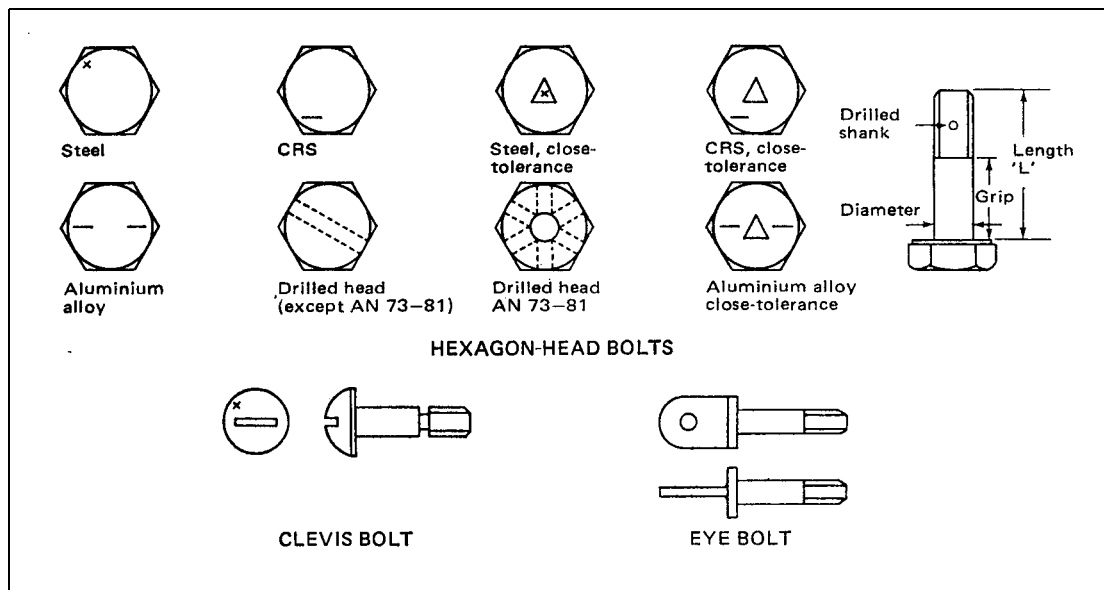

Figure 1 Early Series AN Bolts

3.2.2 All of the bolts listed in Table 1 may be identified as to type by reference to the head marking or position of the locking wire holes. Diameter may be identified by experience, or by measurement and reference to the specification. Other dimensions such as grip length, head size and thread length, must be obtained from the specification.

3.2.3 **Coding.** For identification purposes the AN number is used to indicate the type of bolt and its diameter, and a code is used to indicate the material, length and thread (where these vary) and the position of the locking wire or cotter pin (split pin) hole.

- a) **Diameter.** The last figure or last two figures of AN number indicate the diameter of the thread. 1 = No. 6, 2 = No. 8, 3 = No. 10, and 4 = $\frac{1}{4}$ in, and subsequent numbers indicate the diameter in $\frac{1}{16}$ in increments; above $\frac{5}{8}$ in the available sizes are in $\frac{1}{8}$ steps, but are still coded in sixteenths. Thus an AN 4 is a hexagon head bolt with $\frac{1}{4}$ in thread, an AN 14 is a hexagon head bolt with a $\frac{7}{8}$ in ($\frac{14}{16}$) thread and an AN 182 is a close-tolerance bolt with a $\frac{3}{4}$ in ($\frac{12}{16}$) thread (the numbering in this case starting at 173). An exception to this is the eye bolt, where different diameter pin holes affect the coding; AN 42 is No.10, AN 43 is $\frac{1}{4}$ in, AN 44 is $\frac{5}{16}$ in with a $\frac{1}{4}$ in diameter pin hole, and AN 45 is $\frac{5}{16}$ in with a $\frac{5}{16}$ in diameter pin hole.
- b) **Length.** The length of a bolt as quoted in the specifications, is the overall length from under the head to the end of the shank (L in Figure 1), but the length is generally regarded as from under the head to the first full thread (excluding the chamfer) and is quoted in $\frac{1}{8}$ in increments as a 'dash' number. The last figure of the dash number represents eighths of an inch, and the first figure of the dash number represents inches. Thus an AN 4–12 is a $\frac{1}{4}$ in hexagon-head bolt $1\frac{1}{4}$ in (i.e. $1\frac{2}{8}$) long, and an AN 12–24 is a 3 in hexagon-head bolt $2\frac{1}{2}$ in long. The total lengths quoted in the specifications for these bolts, is actually $1\frac{9}{32}$ in and $2\frac{21}{32}$ in, respectively. Clevis bolts (AN 21 to 36) do not follow this coding, but the length is indicated in $\frac{1}{16}$ in increments by the dash number; thus an AN 29–9 is $\frac{9}{16}$ in long.
- c) **Position of Drilled Hole.** Bolts are normally supplied with a hole drilled in the threaded part of the shank, but different arrangements may be obtained by use of the following code:
- Drilled shank = normal coding, e.g. AN 24–15.
 - Undrilled shank = A added after dash number, e.g. AN 24–15A.
 - Drilled head only = H added before dash number (replacing the dash sign) and A added after dash number, e.g. AN 6H10A.
 - Drilled head and shank = H added before dash number, e.g. AN 6H10.
- d) **Material.** The standard coding applies to a non-corrosion-resistant, cadmium-plated steel bolt. Where the bolt is supplied in other materials, letters are placed after the AN number as follows:
- C = corrosion-resistant steel (CRS)
 - DD = aluminium alloy, e.g. AN 6DD10.
- e) **Thread.** Where the bolt is supplied with either UNF or UNC threads, a UNC thread is indicated by placing an 'A' in place of the dash, e.g. AN 74A6.

Table 2 Early Series AN Machine Screws

AN Number	Type	Material	Process	Head Marking ¹	Nominal Range of Thread Sizes	Thread	
500	Screw, fillister head	Steel	Cad.plated		No.2 to $\frac{3}{8}$ in	UNC	
		CRS	Nil				
		Brass	Nil				
501	Screw, fillister head	Steel	Cad.plated		No.0 to $\frac{3}{8}$ in	UNF	
		CRS	Nil				
		Brass	Nil				
502	Screw, fillister head (drilled)	Steel	Cad.plated	XX	No.10 to $\frac{5}{16}$ in	UNF	
503	Screw, fillister head (drilled)	Steel	Cad.plated	XX	No.6 to $\frac{5}{16}$ in	UNC	
505	Screw, flat 82°	Steel	Cad.plated	--	No.2 to $\frac{3}{8}$ in	UNC	
		CRS	Nil				
		Brass	Nil				
		Al. alloy	Anodised				
507	Screw, flat 100°	Steel	Cad.plated	--	No.6 to $\frac{1}{4}$ in	UNC and UNF	
		CRS	Nil				
		Brass	Black oxide				
		Brass	Nil				
		Al. alloy	Anodised				
509	Screw, flat 100° Structural	Steel	Cad.plated	XX	No.8 to $\frac{5}{16}$ in	UNF	
		Al. alloy	Anodised				
		Bronze	Cad.plated				= =
		Bronze	Nil				= =
510	Screw, flat 82°	Steel	Cad.plated		No.5 to $\frac{1}{4}$ in	UNF	
		CRS	Nil				--
		Brass	Nil				
		Al. alloy	Anodised				
515	Screw, round head	Steel	Cad.plated		No.5 to $\frac{3}{8}$ in	UNC	
		CRS	Nil				--
		Brass	Nil				
		Al. alloy	Anodised				
520	Screw, round head	Steel	Cad.plated		No.5 to $\frac{1}{4}$ in	UNF	
		CRS	Nil				--
		Brass	Nil				
		Al. alloy	Anodised				
525	Screw, washer head	Steel	Cad.plated		No.8 to $\frac{1}{4}$ in	No.8 UNC & UNF No.10 UNF $\frac{1}{4}$ in UNF	
526	Screw, truss head	Steel	Cad.plated		No.6 to $\frac{1}{4}$ in	UNF and UNC	
		CRS	Nil				--
		Al. alloy	Anodised				

1. Only one Symbol may be found on some screw heads

3.3 Early Series AN Machine Screws

3.3.1 Screws differ from bolts in being made from a lower strength material, having a looser fit (class 2A thread instead of class 3A) and having a slotted or a cruciform-recessed head, for rotation by a suitably-shaped screwdriver. The thread is usually continued up to the head, but the shank of 'structural' screws (i.e. AN 509 and 525) has a plain portion and may be used in locations where shear loading is present. Some screw heads are marked to indicate the material from which they are made, and these markings are listed in Table 2. The markings, head shape and material will enable identification of a particular screw to be made. Table 2 lists the AN machine screws, and Figure 2 illustrates the various head shapes. It should be noted that some of these screws are obsolescent, and may not be available in the full range of sizes.

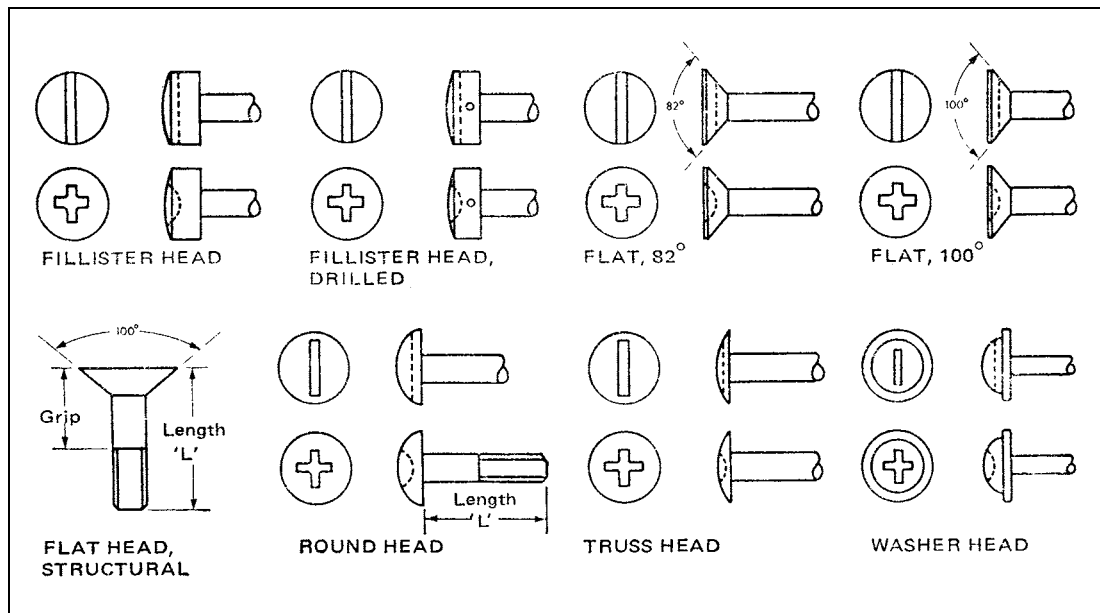

Figure 2 Early Series AN Screws

3.3.2 **Coding.** Screws are coded by the AN number, to indicate the type (e.g. round head), with letters to indicate material (and in some cases the shape of the screwdriver recess), and two dash numbers indicating diameter and length. In addition, some are coded to indicate whether the head is drilled or not.

- a) **Diameter.** The coding for the diameter depends on whether the screw is available with only fine or coarse threads, or with either type of thread. Diameter is indicated by the first dash number.
 - i) Screws available with only one type of thread are coded by the thread number or diameter in sixteenths of an inch. For example, No. 4 (UNC or UNF) = -4, No. 10 (UNC or UNF) = -10, ¼ in (UNC or UNF) = -416, 5/16 in (UNC or UNF) = -516, etc.
 - ii) Screws available with both coarse and fine threads (AN 507, AN 525 and AN 526) are coded by the thread number or diameter in sixteenths of an inch, followed by the number of threads per inch. For example, No. 6-32 (UNC) = -632, No. 8-36 (UNF) = -836, ¼-20 (UNC) = -420, ¼-28 (UNF) = -428, etc.
 - iii) AN 525 screws are available in only one coarse thread size (No. 8) and this is coded -832. The remaining sizes are coded in accordance with i).

- b) **Length.** The second dash number indicates the length (L in Figure 2) of a screw in sixteenths of an inch. AN 509 screws are an exception to this rule, the actual length of the screw being $1/32$ in longer than the size indicated by the code.
- c) **Material.** Material is indicated by a letter (or letters) placed after the AN number as follows:
- Steel = no letter
 - CRS = C
 - Brass (unplated), AN 507 = UB, and other screws = B
 - Brass (black oxide), AN 507 = B
 - Aluminium alloy, AN 507, 509 and 526 = DD, and other screws = D
 - Bronze (cad.plated), AN 509 = P
 - Bronze (unplated), AN 509 = Z
- d) **Head Recess.** Where a screwdriver slot is required the basic code only is used. Where a cruciform recess is required, 'R' is added instead of the second dash.
- e) **Drilled Head.** AN 500 and 501 screws are provided with plain or drilled heads. The letter A before the first dash number indicates a screw with a drilled head.

f) Examples of Coding

- i) An AN 500A6–32 is a fillister head screw with a locking wire hole. It is made of cadmium-plated steel, has a No. 6 (UNC) thread, has a slotted head and is 2 in long.
- ii) An AN 507C832R8 is a 100° flat head screw in corrosion-resistant steel. It has a No. 8–32 (UNC) thread, has a cruciform recessed head and is $1/2$ in long.
- iii) An AN 509DD416–20 is a 100° flat head, structural screw in aluminium alloy. It has a $1/4$ in (UNF) thread, has a slotted head and is $1\ 9/32$ in long.

3.4 Early Series AN Nuts

- 3.4.1 These nuts are made in a variety of different materials, and should normally be used with early series AN bolts and AN screws. Some nuts are designed specifically for use in engines and should not be used in airframe locations; they are thicker than standard airframe nuts. Early series AN nuts are not marked for identification purposes, but can be recognised from their shape and surface finish. Table 3 gives a list of these nuts, and Figure 3 illustrates the various types. As with the AN screws, some nuts may be obsolescent, and not available in the full range of sizes.

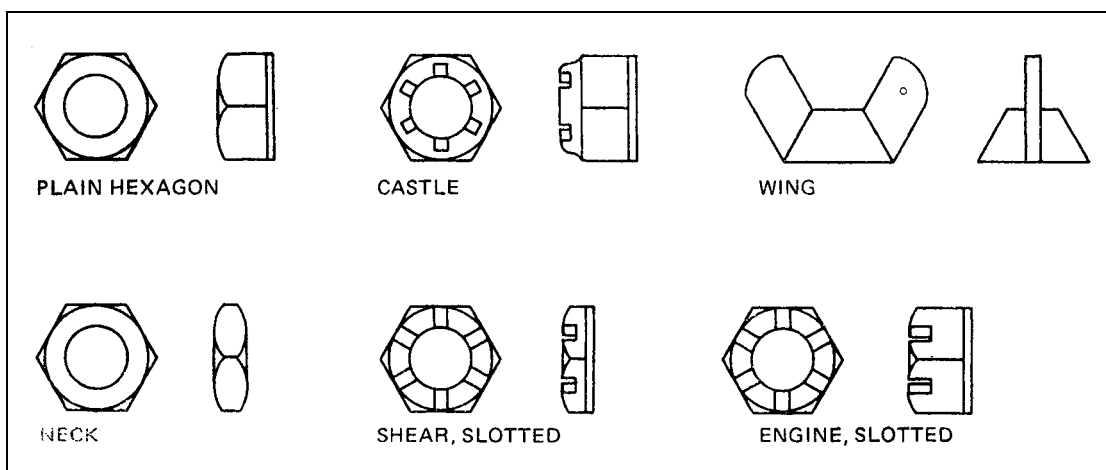

Figure 3 Early Series AN Nuts

3.4.2 **Coding.** The nuts listed in Table 3 are coded according to the type and size of thread, indicated by a dash number placed after the AN number. Those nuts which are intended for use with AN bolts have the same code as the bolts, i.e. a number indicating thread diameter in sixteenths of an inch, and No.6, No.8 and No.10 threads being -1, -2 and -3 respectively. Those nuts intended for use with machine screws (AN 340 and 345) are coded according to the code for screws. The code represents the thread number (-0 to -10) or the diameter in sixteenths of an inch (-416, -516, etc.) as detailed in paragraph 3.2.3 a) i). Wing nuts (AN 350) are coded by the thread designation (-640, -832, etc.) or thread diameter in the fraction sizes (-4 = ¼ in, -5 = 5/16 in, etc.). Material is indicated by a letter placed in the code instead of the dash; C = corrosion-resistant steel, DD = aluminium alloy, machine-screw nuts, D = other aluminium alloy nuts, B = brass, and the absence of a letter indicates a non-corrosion-resistant steel nut. With AN 315 and 316 nuts, 'L' or 'R' is added after the code to indicate left- or right-hand threads. Examples of this coding are: AN 350B4 is a brass wing nut to fit a ¼ in bolt, and AN 316-6L is a steel check nut to fit a 3/8 in bolt with a left-hand thread.





Table 3 Early Series AN Nuts

AN Number	Type	Material	Process	Nominal Range of Thread Sizes	Thread
310	Nut, castle	Steel	Cad.plated	No.10 to ¼ in	UNF
		CRS	Nil		
		Al. alloy	Anodised		
315	Nut, Plain	Steel	Cad.plated	No.6 to 1¼ in (also left-hand thread)	UNF
		CRS	Nil		
		Al. alloy	Anodised		
316	Nut, check	Steel	Cad.plated	¼ to 1 in (also left-hand thread)	UNF
320	Nut, castle, shear	Steel	Cad.plated	No.6 to 1¼ in	UNF
		CRS	Nil		
		Al. alloy	Anodised		
340	Nut, machine screw, hexagon	Steel	Cad.plated	No.2 to ¼ in	UNC
		CRS	Nil	No.2 to ¼ in	
		Brass	Nil	No.2 to No.6	
		Al. alloy	Anodised	No.6 to 3/8 in	
345	Nut, machine screw, hexagon	Steel	Cad.plated	No.0 to ¼ in	UNF
		CRS	Nil	No.0 to ¼ in	
		Brass	Nil	No.0 to No.10	
		Al. alloy	Anodised	No.10 to ¼ in	
350	Nut, wing	Steel	Cad. plated	No.6 to ½ in	UNF
		Brass	Nil		
355	Nut, engine, slotted	Steel	Cad. plated	No.10 to ¾ in	UNF
360	Nut, engine, plain	Steel	Cad. plated	No.10 to ¾ in	UNF

3.5 Early Series AN Washers

3.5.1 AN Standards include three types of washers, and, although these have been replaced in later aircraft designs by MS washers, they may still be found on some older types of aircraft and are included for reference. These washers are listed and illustrated in Table 4.

Table 4 Early Series AN Washers

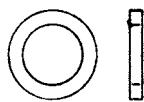
AN Number	Type	Shape	Material	Process	Material Code
935	Washer, lock, spring		Steel Bronze CRS	} Cadmium plated Nil	Nil B C
936	Washer, Shakeproof	A  B  C 	Steel	Cadmium plated	Nil
			Bronze	Tinned	B
960	Washer, Plain		Steel	Cadmium plated	Nil
			CRS	Nil	C
			Brss	Nil	B
			Al. alloy	Nil	D
			Al. alloy	Anodised	PD

3.5.2 **Coding.** Washers are identified by the AN number, a dash number to indicate size, and letters to indicate material and finish.

- Size.** The size of a washer is related to the size of bolt it is designed to fit, and the dash number is in accordance with the code outlined in paragraph 3.3.2 a) i).
- Material.** Material is indicated in the code by adding the letters shown in Table 4.
- Thickness.** AN 935 and 960 washers may be available in light or regular thickness, the light washer being indicated by an 'L' at the end of the code. Actual thicknesses should be obtained from the AN Standard.

d) **Examples**







- AN 936A416B is a style A regular shakeproof washer designed to fit a ¼ in bolt and is made of bronze.
- AN 960 C-616L is a light plain washer in corrosion-resistant steel, for a ¾ in bolt.

3.6 Late Series AN Fasteners

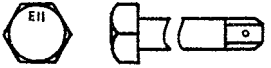
3.6.1 These fasteners are all marked to show the material from which they are made. When ordering a particular fastener, the part number should be taken from the tables in the appropriate specification, since the size cannot be determined from a standard coding. Tables 5, 6 and 7 list the various bolts, screws and nuts which are currently available in this series of specifications, and give the range of numbers allocated to each type.

- 3.6.2 Late series AN bolts are listed in Table 5 and are available in sizes 10–32, ¼–28, 5/16–24, 3/8–24, 7/16–20, ½–20, 9/16–18, 5/8–18 and ¾–16.

Table 5 Late Series AN Bolts

AN Number	Type	Material	Identification
101001-101900	Bolt, hexagon head	Alloy steel (AMS 6322) cadmium plated	
101901-102800	Bolt, hexagon head, drilled shank		
102801-103700	Bolt, hexagon head, drilled head (1 hole)		
103701-104600	Bolt, hexagon head, drilled head (6 holes)		
104601-105500	Bolt, hexagon head	Corrosion-resistant steel (AMS 7472)	
105501-106400	Bolt, hexagon head, drilled shank		
106401-107300	Bolt, hexagon head, drilled head (1 hole)		
107301-108200	Bolt, hexagon head, drilled head (6 holes)		

- 3.6.3 Late series AN screws are listed in Table 6, and are available in the sizes shown.
- 3.6.4 Late series AN nuts are listed in Table 7 and are available in the sizes shown.
- 3.6.5 A plain washer is also available in the late series AN specifications. This is a plain steel washer of cadmium plated steel (AMS 6350), made to fit bolts in sizes No.10 to 1 in, and given a number in the range 122576 to 122600. The washers are rubber stamped with the mark 'E 23'.

4 MS Fasteners

- 4.1 A wide variety of fasteners are available in the MS range. All of these fasteners are marked to show the material from which they are made or the MS specification to which they conform; in addition, most fasteners are marked with the manufacturer's identification. Bolts and screws are marked on their heads, and nuts are marked either on the flat (hexagon nuts) or on the top face (other types). To assist in identification, Figure 4 illustrates the various types of bolt and screw heads in this series, and these are referred to in the appropriate Tables. Nuts are similar to those illustrated in Table 7.

Table 6 Late Series AN Screws











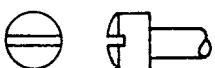

AN Number	Type	Material	Sizes	Identification
116901-116912	Screw, oval fillister	Carbon steel (AMS 5061) cadmium plated	4-40	
116913-116924	Screw, oval fillister, drilled		4-40	
116925-116960	Screw, oval fillister		6-32	
116961-117000	Screw, oval fillister, drilled		6-32	
117001-117040	Screw, oval fillister		8-32	
117041-117080	Screw, oval fillister, drilled		8-32	
115401-115600	Screw, flat fillister	Alloy steel (AMS 6322) cadmium plated	UNF No.10 to 3/8 in	
115601-115800	Screw, flat fillister, drilled shank			
115801-116150	Screw, flat fillister, drilled head		No.10 UNF 1/4 to 3/8 in UNF 1/4 to 3/8 in UNC	

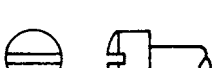
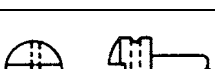
Table 7 Late Series AN Nuts

AN Number	Type	Material	Sizes	Identification
121501-121525	Nut, hexagon, plain	Alloy steel (AMS 6322) cadmium plated	No.10 to 1 in UNF	
121551-121575	Nut, hexagon, castle			
121526-121550	Nut, hexagon, plain	Corrosion-resistant steel (AMS 7472)		
121576-121600	Nut, hexagon, castle			
150401-150425	Nut, hexagon, check	Alloy steel (AMS 6320) cadmium plated	No.10 to 3/4 in UNF	
150426-150450	Nut, hexagon, shear, slotted			

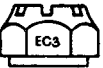
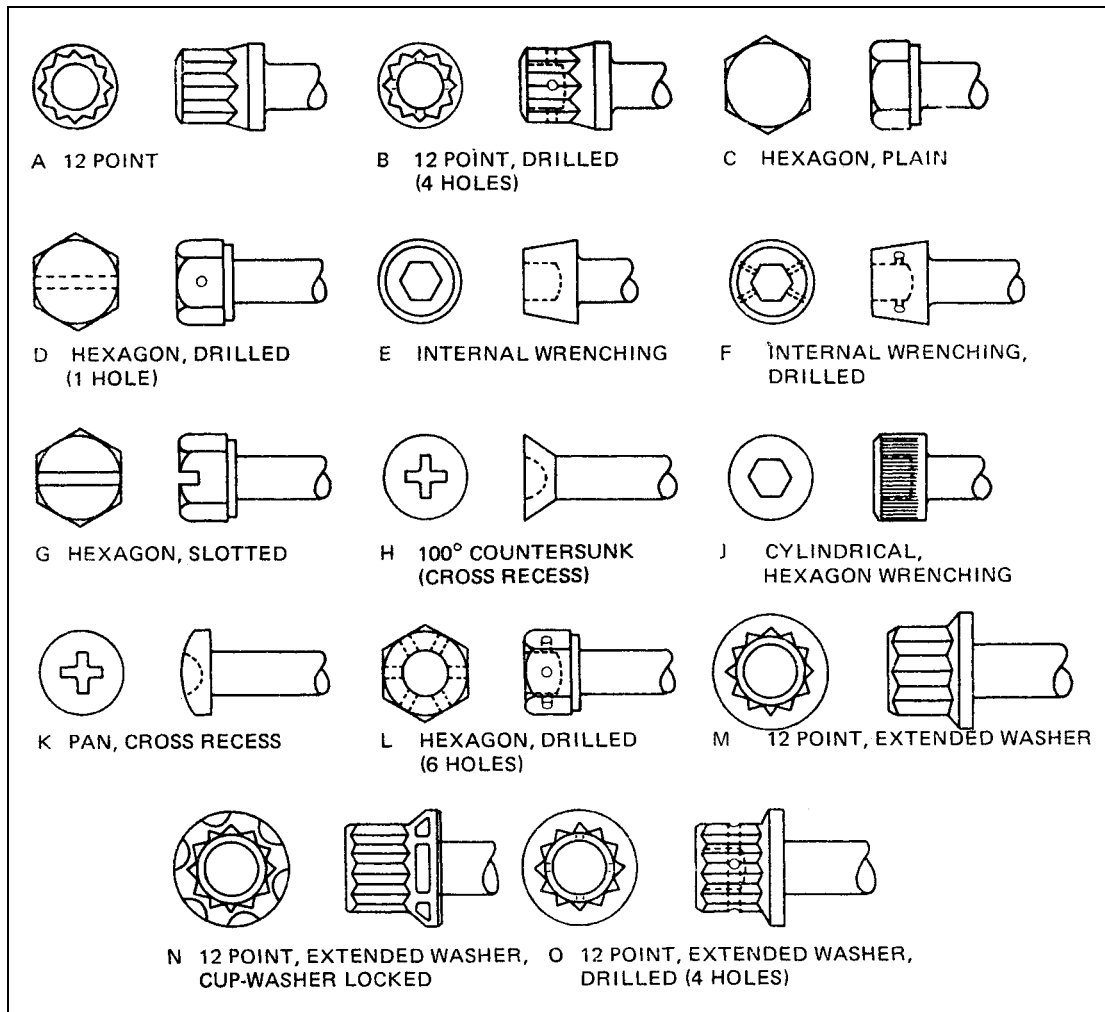

Figure 4 MS Bolts and Screws

4.2 MS Bolts

4.2.1 Table 8 lists a wide range of bolts and screws in the MS series. It should be noted however, that the term 'bolt' is applied to the whole range of sizes in which a particular item is supplied. In the specifications, an item with a No. 8 or smaller thread is generally termed a 'screw', regardless of the fact that it is identical in shape and material to a larger item, which is termed a 'bolt'. However, in some cases the term 'bolt' is also applied to an item with a No. 8 thread.

4.2.2 **Coding.** For most of the items listed in Table 8, the MS number relates to an item of a particular diameter, and a table provided in the specification details the range of lengths available in that size. Length is indicated by a dash number, but the length indicated by a particular dash number varies with the diameter, so that the complete part number of a particular item can only be determined by reference to the specifications.

Table 8 Early Series AN Machine Screws

MS Number	Type	Head Shape (Fig.4)	Head Marking	Thread	Thread Size Range	Material ¹	Plating
9033-9038	Bolt, 12 point, heat resistant	A	EH 19	UNF	No.10 - ½ in	AMS 5735	Nil
9060-9066	Bolt, 12 point, drilled, extended washer head	O	EH 19	UNF	No.10 - ½ in	AMS 5735	Nil
9088-9094	Bolt, 12 point, drilled head	B	E 11	UNF	No.10 - 9/16 in	AMS 6322	Cad.
9110-9113	Bolt, 12 point, extended washer head	M	MS No.	UNF	No.10 - 3/8 in	AMS 5731	Nil
9146-9152	Bolt, 12 point	A	E 11	UNF	No.10 - 9/16 in	AMS 6322	Cad.
9157-9163	Bolt, 12 point	A	E 11	UNF	No.10 - 9/16 in	AMS 6322	Black oxide
9169-9175	Bolt, 12 point, drilled head	B	E 11	UNF	No.10 - 9/16 in	AMS 6322	Black oxide
9177 and 9178	Screw, 12 point, extended washer head	N	EH 19	UNF	No.6 & No.8	AMS 5735	Nil
9183 and 9184	Screw, 12 point, drilled head	B	E 11	UNF	No.6 & No.8	AMS 6322	Cad.
9185 and 9186	Screw, 12 point	A	E 11	UNF	No.6 & No.8	AMS 6322	Cad.
9189 and 9190	Screw, 12 point	A	E 11	UNF	No.6 & No.8	AMS 6322	Black oxide
9191 and 9192	Screw, 12 point, drilled head	B	E 11	UNF	No.6 & No.8	AMS 6322	Black oxide
9206-9214	Bolt, 12 point, extended washer head	M	MS No.	UNJF	No.6 - 9/16 in	AMS 6304	Diffused nickel cadmium
9215-9222	Bolt, 12 point, extended washer drilled head	O	MS No.	UNJF	No.6 - ½ in	AMS 6304	Diffused nickel cadmium
9224	Bolt, 12 point, heat resistant	A	EH 19	UNF	9/16 in	AMS 5735	Nil
9281-9291	Bolt, hexagon head	C	MS No.	UNF	No.4 - 3/4 in	AMS 6322	Black oxide
9292-9302	Bolt, hexagon head, drilled	D	MS No.	UNF	No.4 - 3/4 in	AMS 6322	Black oxide
9438-9448	Bolt, hexagon head, drilled	D	MS No.	UNJF	No.6 - 3/4 in	AMS 6304	Diffused nickel cadmium

Table 8 Early Series AN Machine Screws (Continued)

MS Number	Type	Head Shape (Fig.4)	Head Marking	Thread	Thread Size Range	Material ¹	Plating
9449-9459	Bolt, hexagon head	C	MS No.	UNJF	No.6 - 3/4 in	AMS 6304	Diffused nickel cadmium
9487-9497	Bolt, hexagon head	C	MS No.	UNJF	No.8 - 3/4 in	AMS 5731	Nil
9498-9508	Bolt, hexagon head, drilled	D	MS No.	UNJF	No.6 - 3/4 in	AMS 5731	Nil
9516-9526	Screw, hexagon head	C	MS No.	UNJF	No.4 - 3/4 in	AMS 6322	Cad.
9527-9537	Screw, hexagon head, drilled	D	MS No.	UNJF	No.4 - 3/4 in	AMS 6322	Cad.
9554-9562	Bolt, 12 point, extended washer head, PD shank	M	MS No.	UNJF	No.6 - 9/16 in	AMS 5731	Nil
9563-9571	Bolt, 12 point, ext. washer, drilled head, PD shank	O	MS No.	UNJF	No.6 - 9/16 in	AMS 5731	Nil
9572-9580	Bolt, 12 point, extended washer head	M	MS No.	UNJF	No.6 - 9/16 in	AMS 5731	Silver plated
9583-9591	Bolt, hexagon head, drilled	L	MS No.	UNJF	No.10 - 3/4 in	AMS 5731	Nil
9676-9679	Bolt, 12 point, extended washer head, cupwasher locked	N	MS No.	UNJF	No.10 - 5/8 in	AMS 5731	Nil
9680-9683	Bolt, 12 point, extended washer head, cupwasher locked	N	MS No.	UNJF	No.10 - 3/8 in	AMS 6322	Cad.
9694-9702	Bolt, 12 point, extended washer head	M	MS No.	UNJF	No.4 - 9/16 in	AMS 5708	Nil
9712-9720	Bolt, 12 point, extended washer, drilled	O	MS No.	UNJF	No.4 - 9/16 in	AMS 5708	Silver plated
9730-9738	Bolt, 12 point, extended washer, PD shank	M	MS No.	UNJF	No.4 - 9/16 in	AMS 5643	Nil
9739-9747	Bolt, 12 point, extended washer, drilled, PD shank	O	MS No.	UNJF	No.4 - 9/16 in	AMS 5643	Nil
9748-9756	Bolt, 12 point, extended washer head, PD shank	M	MS No.	UNJF	No.4 - 9/16 in	Titanium	Nil

Table 8 Early Series AN Machine Screws (Continued)

MS Number	Type	Head Shape (Fig.4)	Head Marking	Thread	Thread Size Range	Material ¹	Plating
9757-9765	Bolt, 12 point, extended washer drilled head, PD shank	O	MS No.	UNJF	No.4 - ⁹ / ₁₆ in	Titanium	Nil
9883-9891	Bolt, 12 point, extended washer head	M	MS No.	UNJF	No.4 - ⁹ / ₁₆ in	AMS 5616	Nil
20004-20024	Bolt, internal wrenching	E or F	MS No.	UNF	¹ / ₄ to 1 ¹ / ₂ in	Alloy steel	Cad.
20033-20046	Bolt, hexagon head, 1200°F	C	1200	UNF	No.10 - 1 in	Corrosion-and heat-resisting steel	Nil
20073 & 20074	Bolt, hexagon head, drilled	D	X	-73 =UNF -74 =UNC	No.10 – ³ / ₄ in	Alloy steel	Cad.
21095	Bolt, self-locking, 250°F, hexagon head	C	-	UNF	No.10 – 1 ¹ / ₄ in	CRS	Nil
21096	Bolt, self-locking, 250°F, pan head + recess	K	Nil	4,6,8=UNC, larger = UNF	No.4 - ¹ / ₂ in	Alloy steel	Cad.
21097	Bolt, self-locking, 250°F, pan head + recess	K	Nil	4,6,8=UNC, larger = UNF	No.4 - ¹ / ₂ in	CRS	Nil
21250	Bolt, 12 point, 180 000 lbf/in ² , drilled or plain	A or B	MS No.	UNF	¹ / ₄ - 1 ¹ / ₂ in	Alloy steel	Cad.
21277-21285	Bolt, 12 point, extended washer head	M	MS No.	MIL-S-8879	No.4 - ⁹ / ₁₆ in	AMS 5735	Nil
21286-21294	Bolt, 12 point, extended washer, drilled	O	MS No.	MIL-S-8879	No.4 - ⁹ / ₁₆ in	AMS 5735	Nil

1. AMS 6304 and AMS 6322 are low alloy steels.
All other AMS specifications in the Table are corrosion and heat-resisting alloys.

Table 9 MS Screws





MS Number	Type	Head Shape (Fig.4)	Head Marking	Thread	Thread Size Range	Material	Plating
9122 and 9123	Screw, hex. head, slotted	G	E 11	UNF	No.10 and ¼ in	AMS 6322	Cadmium
21262	Screw, cyl. head, 160 KSI int. wren. 250°F	J	· · · · · ·	4,6,8=UNC Larger = UNF	No.4 - 5/8 in	Alloy steel	Cadmium
21295	Screw, cyl. head, 160 KSI int. wren. 250°F	J	· · · · · ·	4,6,8=UNC Larger = UNF	No.4 - 5/8 in	CRS	Nil
24693	Screw, flat 100°, + recess	H	-	UNC 2A UNF 2A	No.6 - 3/8 in	CRS	Nil
24694	Screw, flat 100°, + recess	H	-	UNC 3A UNF 3A	No.6 - 9/16 in	CRS	Nil
27039	Screw, pan head, + recess, structural	K	$\frac{B}{C}$	8=UNC Larger = UNF	No.8 - ½ in	Bronze Alloy steel CRS	Nil Cadmium Nil
35297	Screw, cap, hex. head	C		UNC 2A	¼ in	Carbon steel	Cad. or zinc
35299	Screw, cap, hex. head	C		UNC 2A	¼- 1¼ in	Carbon steel	Phosphate
35307	Screw, cap, hex. head	C		UNC 2A	¼- 1¼ in	CRS	Nil
35308	Screw, cap, hex. head	C		UNF 2A	¼- 1¼ in	CRS	Nil

Table 9 MS Screws (Continued)













MS Number	Type	Head Shape (Fig.4)	Head Marking	Thread	Thread Size Range	Material	Plating
51095	Screw, cap, hex. head, drilled	D		UNC 2A	¼ - 1 in	Carbon steel	Cadmium
51096	Screw, cap, hex. head, drilled	D		UNF 2A	¼ - 1 in	Carbon steel	Cadmium
51099	Screw, cap, hex. head, drilled	D		UNC 2A	¼ - 1 in	CRS	Nil
51100	Screw, cap, hex. head, drilled	D		UNF 2A	¼ - 1 in	CRS	Nil
51105	Screw, cap, hex. head, drilled	D		UNC 2A	¼ - 1 in	Carbon steel	Cadmium
51106	Screw, cap, hex. head, drilled	D		UNF 2A	¼ - 1 in	Carbon steel	Cadmium
51107	Screw, cap, hex. head, drilled shank	C		UNC 2A	¼ - 1 in	Alloy steel	Phosphate
51108	Screw, cap, hex. head, drilled shank	C		UNF 2A	¼ - 1 in	Alloy steel	Phosphate
51109	Screw, cap, hex. head, drilled shank	C		UNC 2A	¼ - 1 in	CRS	Nil
51110	Screw, cap, hex. head, drilled shank	C		UNF 2A	¼ - 1 in	CRS	Nil

Table 9 MS Screws (Continued)

MS Number	Type	Head Shape (Fig.4)	Head Marking	Thread	Thread Size Range	Material	Plating
90726	Screw, cap, hex. head	C		UNF 2A	1/4 - 1 1/2 in	Carbon steel	Cadmium
90727	Screw, cap, hex. head	C		UNF 2A	1/4 - 1 1/2 in	Alloy steel	Cadmium
90728	Screw, cap, hex. head	C		UNC 2A	1/4 - 1 1/2 in	Alloy steel	Cadmium

4.2.3 With bolts in the ranges MS 20004 to 20024 and MS 20033 to 20046, the thread size is indicated by the part number as outlined in paragraph 3.2.3(a), and the length is indicated by a dash number, which represents grip length in sixteenths of an inch.

4.2.4 With bolts in the MS 21250 series, the dash number indicates both diameter and length. The first two figures indicate diameter in sixteenths of an inch, and the last two figures indicate grip length in sixteenths of an inch.

4.2.5 With the MS 20004 to 20024, and MS 21250, bolts, an H in place of the dash indicates a drilled-head bolt.

4.3 MS Screws

4.3.1 Table 9 lists a variety of the screws covered by MS specifications, and shows the features by which these screws may be partially identified.

4.3.2 Because the individual specifications vary, the screws listed in Table 9 should be fully identified by reference to the particular specification.

4.4 MS Nuts

4.4.1 The non-self-locking nuts to MS specifications are listed in Table 10. These nuts are similar in appearance to those shown in Table 7, but all are marked with the appropriate MS part number for identification purposes.

442

Table 10 MS Non-self-locking Nuts

MS Number	Type	Thread	Size Range	Material	Plating
9356	Nut, plain, hexagon	No.4, 6 and 8 nuts have UNC thread	No.4 - 1 in	AMS 5735	Nil
9357	Nut, plain, hexagon		No.4 - 1 in		Silver
9358	Nut, castle	Larger size nuts have UNF thread	No.10 - 1 in		Nil
9359	Nut, castle		No.10 - 1 in		Silver
9360	Nut, plain, hexagon, drilled		No.10 - 1 in		Silver
9361	Nut, plain, hexagon, check		No.10 - 1 in		Nil
9362	Nut, plain, hexagon, check		No.10 - 1 in		Silver
9363	Nut, hexagon, slotted, shear		No.10 - 1 in		Nil
9364	Nut, hexagon, slotted, shear		No.10 - 1 in		Silver

4.4.2 **Coding.** Nuts are coded by the MS number plus a dash number indicating thread size –04 is No. 4, –06 is No. 6, –08 is No. 8, –09 is No. 10, –10 is ¼ in, –11 is 5/16 in, –12 is 3/8 in, –13 is 7/16 in, –14 is ½ in, –15 is 9/16 in, –16 is 5/8 in, –17 is ¾ in, –18 is 7/8 in, and –19 is 1 in.

4.5 **MS Washers.** Two ranges of washers are covered in the MS series. MS 35338 is a cadmium-plated, steel, spring washer, and replaces the AN 935 regular spring washer. MS 35333 and 35335 are lock washers in cadmium-plated steel and bronze, which replace the AN 936 style A and style B shakeproof washers, respectively. All of these washers are ordered by the MS number, followed by a dash number indicating the size of bolt the washer is designed to fit. The dash number applicable to a particular washer should be obtained from the tables provided in the specification.

5 NAS Fasteners

5.1 NAS Specifications provide a wide range of fasteners, with a variety of head shapes and wrenching recesses (Figure 5). The range of bolts and screws includes both self-locking and non-locking versions, and many varieties are also available with oversize shanks for repair work. A few washers and nuts are also included in the NAS specifications, but these items are generally supplied under manufacturers' specifications and are not included in this Leaflet.

5.2 All NAS bolts and screws are marked for identification purposes, but the extent of the marking depends on the size of the head and on the requirements of the particular specification. Many components are marked in accordance with NAS 1347, which provides for four types of identification. Type I is the material code and is the same as that shown in Figure 1 for AN bolts; Type II is the basic part number, i.e. the NAS number; Type III is the basic part number and a material code letter; Type IV is the complete part number, including basic part number, material code, figures for diameter and length, and a letter for type of finish. These markings are shown in Table 11, and explained in paragraphs 5.3 and 5.4. It should be noted, however, that in the smaller sizes a shortened version of the code may be permitted by the specification.

On fasteners with a Tri-Wing recess the marking also includes a figure, inside a circle, which indicates the size of the recess in accordance with NAS 4000. Oversize bolts are also marked with an 'X' or 'Y'.

NOTE: Provision is also made for including the manufacturer's identification mark on the head.

5.3 Coding

5.3.1 The bolts and screws listed in Table 11 are coded according to their type, diameter, length, type of plating and material. Where a component is made in more than one material, an alloy steel part is given the basic part number; similarly, where applicable, the basic part number implies that the part is not drilled for locking purposes.

5.3.2 **Diameter.** Most bolts and screws are coded according to thread size in a similar way to AN and MS parts; however, there are some exceptions.

a) NAS 1261 to 1265 and NAS 1266 to 1270 are available in sizes $\frac{9}{16}$ -18, $\frac{5}{8}$ -18, $\frac{3}{4}$ -16, $\frac{7}{8}$ -14, and 1-12; they are coded in numerical order and indicated by an 'A' in Table 11.

b) For bolts and screws which are given a range of numbers (except as detailed in d)), the last figure or two figures indicates the size as follows:

NAS xxx0 = 4-40, xxx1 = 6-32, xxx2 = 8-32, xxx3 = 10-32, xxx4 = $\frac{1}{4}$ -28, xxx5 = $\frac{5}{16}$ -24, xxx6 = $\frac{3}{8}$ -24, xxx7 = $\frac{7}{16}$ -20, xxx8 = $\frac{1}{2}$ -20, xxx9 = $\frac{9}{16}$ -18, xx10 = $\frac{5}{8}$ -18, xx12 = $\frac{3}{4}$ -16, xx14 = $\frac{7}{8}$ -14, xx16 = 1-12, xx18 = $1\frac{1}{8}$ -12, and xx20 = $1\frac{1}{4}$ -12.

The threads are usually UNC, UNF, UNJC or UNJF, but some bolts and screws are also available with American National threads, and these are coded separately. Those parts which comply with the Unified standard are indicated by a 'B' in Table 11.

c) For bolts and screws which are given a single NAS number, the diameter is given by the first dash number as follows:

NAS xxxx-02 = 2-56, xxxx-04 = 4-40, xxxx-06 = 6-32, xxxx-08 = 8-32, xxxx-3 = 10-32, xxxx-4 = $\frac{1}{4}$ -28, and so on, in steps of $\frac{1}{16}$ in, following the sizes given in b). Parts following this code are marked 'C' in Table 11.

d) NAS 1271 to 1280 are available in sizes from $\frac{1}{4}$ to 1 in, and are coded in numerical order.

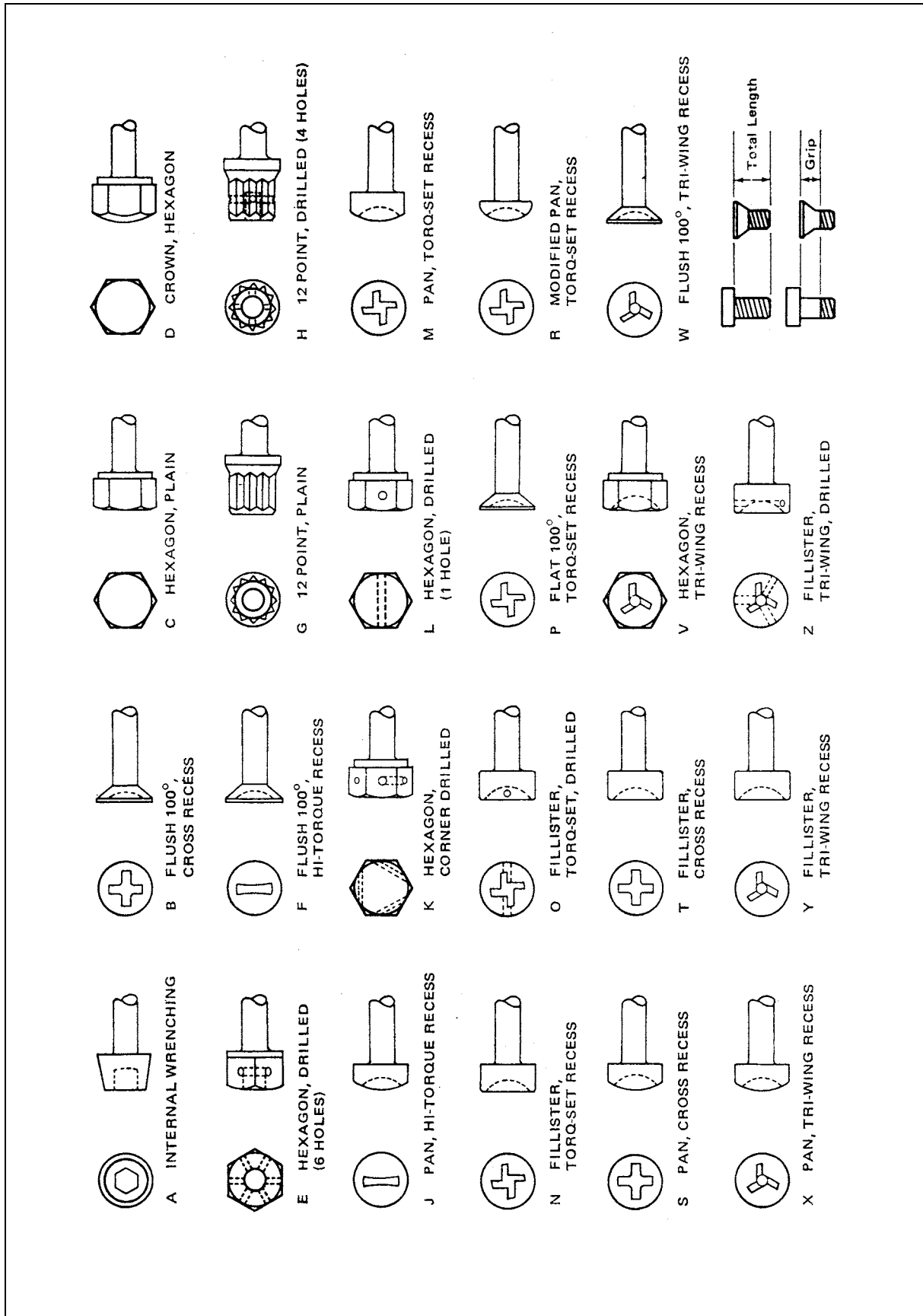

Figure 5 NAS Bolts and Screws

5.3.3 **Length.** The length is indicated by the second dash number for parts with the 'C' diameter code, or the first dash number for all other parts. The length dash number indicates the total length of a part with a full thread or the grip length of a part with a shorter thread (see Figure 5), in sixteenths of an inch; exceptions are NAS 563 to 572, for which the length dash number represents thirty-seconds of an inch, and NAS 428, for which the dash number represents eighths of an inch as detailed in paragraph 3.2.3 b) for AN parts.

5.3.4 **Plating.** Alloy-steel bolts and screws are normally cadmium plated in accordance with QQ-P-416 Type II Class 3. If a different plating is used, or if CRS or titanium parts are plated, the following code may be used:

W = QQ-P-416 Type I Class 3 plating.

B = Blackened Type II plating.

H = CRS with Type II plating.

P = CRS or titanium with Type II plating.

U = Unplated.

A = Aluminium coating to NAS 4006.

5.3.5 **Type of Locking.** Unless otherwise noted in Table 11, the type of locking is indicated as follows:

D = Drilled shank.

H = Drilled head.

L = Nylon strip locking element.

N = Nylon button or pellet locking element.

LK = KEL-F strip locking element.

NK = KEL-F pellet locking element.

K = KEL-F locking element, type optional.

NOTE: The lack of a letter for a self-locking bolt indicates that the type of locking element is unimportant.

5.3.6 **Type of Recess.** Where a choice of wrenching recesses is available, the following code is used to indicate the type required:

T = Torq-Set.

H = Hi-Torque.

P or R = Phillips (cruciform).

NOTE: The type of recess indicated by the lack of a code letter is shown in Table 11.

5.3.7 **Type of Material.** The NAS fasteners listed in Table 11 are manufactured from alloy steel, corrosion-resistant steel (CRS), corrosion-and-heat-resistant (C and HR) steel, and titanium alloy. Except in the case of titanium alloy, which is sometimes indicated by a 'V' (see Table 11), the type of material is not specified unless the fastener is made in more than one material. The basic code applies to alloy steel, and the following code indicates other materials:

CR = corrosion-resistant steel, 125 000 lbf/in².

C = corrosion-resistant steel, 140 000 lbf/in².

E = corrosion-resistant steel, 160 000 lbf/in².

V = titanium alloy.

Table 11 NAS Bolts and Screws



NAS No.	Type	Head (Fig.5)	Size Range	Material	Coding				Head Marking
					Dia.	Replacing Dash or First Dash	Replacing Second Dash	At End	
144-158	Bolt, internal wrenching	A	No.1 - 1¼ in	Alloy steel	B	A = drilled shank DH = drilled head Nil = undrilled			NAS No.
333-340	Bolt, flush 100°, close-tolerance	B	No.10 - 5/8 in	Alloy steel	B	A = undrilled shank P = Phillips recess Nil = hex.socket C = cad.plated shank	-	See Specification for Length Code	NAS No. + 
428	Bolt, crown hex.head	D	No.10 - 3/8 in	Alloy steel	C	H = drilled head K = slotted shank	-	-	NAS 1347 Type IV
464	Bolt, shear, close-tolerance	C	No.10 - 1 in	Alloy steel	C	P = cad.shank	A = undrilled shank		NAS No. + 
501	Bolt, hex.head, non-magnetic	C	No.10 - 1¼ in	CRS	C	A = undrilled shank H = drilled head	-	-	NAS No. + -
560	Screw, 100°, non-magnetic, structural	B	No.8 - 9/16 in	CRS	C	C = low strength H = high temp. X = high strength	K = Phillips recess P = cad.plated	-	NAS No. + C,H, or X
563-572	Bolt, full threaded, fully identified	E	No.10 - 3/4 in	Alloy steel	B	-	-	-	NAS No. + dash no.
583-590	Bolt, 100°, close-tolerance, 160,000 lbf/in ² , Hi-Torque	F	No.10 - 5/8 in	Alloy steel	B	-	-	-	NAS 1347 Type IV

Table 11 NAS Bolts and Screws (Continued)

NAS No.	Type	Head (Fig.5)	Size Range	Material	Coding				Head Marking
					Dia.	Replacing Dash or First Dash	Replacing Second Dash	At End	
624-644	Bolt, 12 point 180,000 lbf/in ²	G or H	¼ - 1½ in	Alloy steel	B	H = drilled head	-	-	NAS No.
653-658	Bolt, hex. head, short thread, close-tolerance	C	No.10 - ½ in	Titanium	B	V = titanium	-	D = drilled shank	NAS No. + dash no. + material
663-668	Bolt, 100°, close-tolerance, long thread	F	No.10 - ½ in	Titanium	B	V = titanium	-	HT = Hi-Torque	NAS 1347 Type IV
673-678	Bolt, hex. head, close-tolerance	C or K	No.10 - ½ in	Titanium	B	V = titanium	-	D = drilled shank H = drilled head	NAS No. + dash no. + material
1003-1020	Bolt, hex. head, non-magnetic, heat-resistant	C or L	No.10 - ¼ in	CRS	B	-	-	A = undrilled H = drilled head Nil = drilled shank	NAS No. + dash no.
1083-1088	Bolt, 100°, close-tolerance, short thread	F	No.10 - ½ in	Titanium	B	V = 6AL-4V alloy T = 4AL-4M _N alloy	-	Nil = Phillips HT = Hi-Torque	NAS 1347 Type IV
1100	Screw, pan head, full thread, Torq-Set	M	No.0 - ¾ in	Alloy steel Titanium CRS	C	C = CRS 140,000 psi E = CRS 160,000 psi V = titanium	-	B = black plating P = type II plating W = type I plating	NAS No. + dash no. + material
1101	Screw, flat fillister, full thread, Torq-Set	N or O	No.0 - ¾ in	As 1100	C	As 1100	H = drilled head	As 1100	NAS No. + dash no. + material
1102	Screw, 100°, full thread, Torq-set	P	No.2 - ¾ in	As 1100	C	As 1100	-	As 1100	NAS No. + dash no. + material

Table 11 NAS Bolts and Screws (Continued)

NAS No.	Type	Head (Fig.5)	Size Range	Material	Coding				Head Marking
					Dia.	Replacing Dash or First Dash	Replacing Second Dash	At End	
1103-1120	Bolt, shear, hex. head, modified short thread	C	No.10 - 1¼ in	Alloy steel	C	As 1100	-	As 1100 D = drilled	NAS No. + dash no. + material
1121-1128	Screw, flat fillister, close-tolerance, short thread	N or O	No.6 - ½ in	As 1100	B	As 1100	-	H = drilled head P and W as 1100	NAS No. + dash no. + material
1131-1138	Screw, pan head, close-tolerance, short thread	M	No.6 - ½ in	As 1100	B	C = CRS V and T as 1083	-	P and W as 1100	NAS No. + dash no. + material
1141-1148	Screw, pan head (mod), close-tolerance, short thread	R	No.6 - ½ in	As 1100	B	As 1100	-	P and W as 1100	NAS No. + dash no. + material
1151-1158	Screw, 100°, close-tolerance, short thread	P	No.6 - ½ in	As 1100	B	As 1131	-	D = drilled shank P and W as 1100	NAS No. + dash no. + material
1161-1168	Screw, 100°, shear, self-locking	P	No.6 - ½ in	Alloy steel CRS	B	E as 1100	-	P and W as 1100 + locking code	NAS No. + dash no. + material + circle of dots
1171-1178	Screw, pan, shear, self-locking	M	No.6 - ½ in	Alloy steel CRS	B	E as 1100	-	P and W as 1100 + locking code	NAS No. + dash no. + material + circle of dots

Table 11 NAS Bolts and Screws (Continued)

NAS No.	Type	Head (Fig.5)	Size Range	Material	Coding				Head Marking
					Dia.	Replacing Dash or First Dash	Replacing Second Dash	At End	
1181-1188	Screw, flat fillister, shear, self-locking	N	No.6 - ½ in	Alloy steel CRS	B	C and E as 1100	-	P and W as 1100 + locking code	NAS No. + dash no. + material + circle of dots
1189	Screw, 100°, full thread, self-locking, 250°F	B or P	No.2 - ¾ in	Alloy steel CRS	C	C as 1100	P = Phillips recess T = Torq-Set recess	W as 1100 + locking code	NAS No. + dash no. + circle of dots
1190	Screw, pan head, full thread, self-locking	M or S	No.2 - ¾ in	Alloy steel CRS	C	C and E as 1100	P = Phillips recess T = Torq-Set recess	H = type II plating W = type I plating + locking code	NAS No. + dash no. + circle of dots
1191	Screw, flat fillister, full thread, self-locking, 250°F	N or T	No.2 - ¾ in	Alloy steel CRS	C	C and E as 1100	P = Phillips recess T = Torq-Set recess	H and W as 1190 + locking code	NAS No. + dash no. + circle of dots
1202-1210	Bolt, 100°, close-tolerance, 160,000 lbf/in ² , short thread	B	No.8 - ⅝ in	Alloy steel	B	-	-	D = drilled shank W as 1190	NAS 1347 Type IV
1216	Bolt, pan head, full thread, Hi-Torque	J	No.4 - ¾ in	Alloy steel CRS	C	-	CR = CRS 125,000 lbf/in ² C = CRS 140,000 lbf/in ²	B = black plating P = type II plating	NAS 1347 Type IV

Table 11 NAS Bolts and Screws (Continued)

NAS No.	Type	Head (Fig.5)	Size Range	Material	Coding				Head Marking
					Dia.	Replacing Dash or First Dash	Replacing Second Dash	At End	
1217	Bolt, pan head, short thread, Hi-Torque	J	No.8 - ³ / ₈ in	Alloy steel CRS	C	-	C and CR as 1216	B and P as 1216	NAS 1347 Type IV
1218	Bolt, pan head, long thread, Hi-Torque	J	No.4 - ³ / ₈ in	Alloy steel CRS	C	-	C and CR as 1216	B and P as 1216	NAS 1347 Type IV
1219	Bolt, 100°, full thread, Hi-Torque	F	No.4 - ³ / ₈ in	Alloy steel CRS	C	-	C and CR as 1216	B and P as 1216	NAS 1347 Type IV
1220	Bolt, 100°, short thread, Hi-Torque	F	No.8 - ³ / ₈ in	Alloy steel CRS	C	-	C and CR as 1216	B and P as 1216	NAS 1347 Type IV
1221	Bolt, 100°, long thread, Hi-Torque	F	No.4 - ³ / ₈ in	Alloy steel CRS	C	-	C and CR as 1216	B and P as 1216	NAS 1347 Type IV
1223-1235	Bolt, hex. head, close-tolerance, self-locking	C	No.10 - 1 ¹ / ₄ in	Alloy steel CRS	B	C = CRS	-	W as 1190 + locking code	NAS 1347 Type IV + circle of dots
1243-1250	Bolt, 100°, close-tolerance, short thread, Hi-Torque, 0.0156 in oversize, 160,000 lbf/in ² (a)	F	No.10 - ⁵ / ₈ in	Alloy steel CRS	B	-	-	-	NAS 1347 Type IV
1253-1260	Bolt, 100°, close-tolerance, short thread, Hi-Torque, 0.0312 in oversize, 160,000 lbf/in ² (a)	F	No.10 - ⁵ / ₈ in	Alloy steel	B	-	-	-	NAS 1347 Type IV

Table 11 NAS Bolts and Screws (Continued)

NAS No.	Type	Head (Fig.5)	Size Range	Material	Coding				Head Marking
					Dia.	Replacing Dash or First Dash	Replacing Second Dash	At End	
1261-1265	Bolt, hex. head, close-tolerance, short thread	C	$\frac{9}{16}$ - 1 in	Titanium	A	-	-	D = drilled shank	NAS 1347 Type IV
1266-1270	Bolt, hex. head, close-tolerance	C	$\frac{9}{16}$ - 1 in	Titanium	A	-	-	D = drilled shank	NAS 1347 Type IV
1271-1280	Bolt, 12 point	G or H	$\frac{1}{4}$ - 1 in	Titanium	D	H = drilled head	-		NAS 1347 Type IV
1303-1320	Bolt, hex. head, close-tolerance, 160,000 lbf/in ²	C or K	No.10 - 1 $\frac{1}{4}$ in	Alloy steel	B	-	-	D = drilled shank H = drilled head W = type I plating	NAS No. + dash no
1503-1510	Bolt, 100°, close-tolerance, short thread, Hi-Torque, 160,000 lbf/in ²	F	No.10 - $\frac{5}{8}$ in	Alloy steel	B	-	-	W = type I plating	NAS No. + dash no
1578	Bolt, pan head, shear, 1200°F	J or M	No.10 - $\frac{1}{2}$ in	C and HR steel (U-212)	C	-	T = Torq-Set recess H = Hi-Torque recess	-	NAS 1347 Type II
1579	Bolt, pan head, Full thread, 1200°F	J or M	No.10 - $\frac{3}{8}$ in	C and HR steel (U-212)	C	-	T and H as 1578	-	NAS 1347 Type II
1580	Bolt, tension, 100°, 1200°F	F or P	No.10 - $\frac{5}{8}$ in	C and HR steel (U-212)	C	-	T and H as 1578	-	NAS 1347 Type II

Table 11 NAS Bolts and Screws (Continued)

NAS No.	Type	Head (Fig.5)	Size Range	Material	Coding				Head Marking
					Dia.	Replacing Dash or First Dash	Replacing Second Dash	At End	
1581	Bolt, shear, 100° reduced, 1200°F	F or P	No.10 - 5/8 in	C and HR steel (U-212)	C	-	T and H as 1578	-	NAS 1347 Type II
1582	Bolt, 100°, Full thread, 1200°F	F or P	No.10 - 3/8 in	C and HR steel (U-212)	C	-	T and H as 1578	-	NAS 1347 Type II
1586	Bolt, tension, 12 point, 1200°F, external wrenching	G or H	1/4 - 1 1/4 in	C and HR steel (U-212)	C	-	H = drilled head	-	NAS 1347 Type II
1588	Bolt, shear, hex. head, 1200°F	C	No.10 - 1 in	C and HR steel (U-212)	C	-	-	-	NAS 1347 Type II
1603-1610	Bolt, 100°, close-tolerance, 0.0312 in oversize, 160,000 lbf/in ² (b)	F or P	No.10 - 5/8 in	Alloy steel	B	-	-	R = Phillips recess Nil = Hi-Torque	NAS 1347 Type IV
1620-1628	Screw, 100°, short thread, Torq-Set recess	P	No.4 - 1/2 in	Alloy steel CRS Titanium	B	C, E and V as 1100	-	D = drilled shank P = type II plating	NAS 1347 Type IV
1630-1634	Screw, pan head, short thread, Torq-Set	M	No.4 - 1/4 in	Alloy steel CRS Titanium	B	C, E and V as 1100	-	D = drilled shank P = type II plating	NAS 1347 Type IV

Table 11 NAS Bolts and Screws (Continued)

NAS No.	Type	Head (Fig.5)	Size Range	Material	Coding				Head Marking
					Dia.	Replacing Dash or First Dash	Replacing Second Dash	At End	
1703-1710	Bolt, 100°, close-tolerance, 0.0156 in oversize, 160,000 lbf/in ² (b)	B or F	No.10 - 5/8 in	Alloy steel	B	-	-	R = Phillips recess Nil = Hi-Torque	NAS 1347 Type IV
2803-2810	Bolt, 100°, close-tolerance, 180,000 lbf/in ² Torq-Set	P	No.10 - 5/8 in	Alloy steel	B	-	-	-	NAS No. + dash no.
2903-2920	Bolt, shear, hex. head, 0.0156 in oversize (b)	C or K	No.10 - 1 1/4 in	Alloy steel	B	E = short thread	-	D = drilled shank H = drilled head W = type I plating	NAS No. + dash no.
3003-3020	Bolt, shear, hex. head, long or short thread, 0.0312 in oversize (b)	C or K	No.10 - 1 1/4 in	Alloy steel	B	E = short thread	-	D = drilled shank H = drilled head W = type I plating	NAS No. + dash no.
4104-4116	Bolt, 100°, close-tolerance, long thread, Tri-wing recess, self-locking and non-locking	W	1/4 - 1 in	Alloy steel	B	B = black plating D,L or P see (g)	-	X = 0.0156 in oversize Y = 0.0312 in oversize	NAS No. + dash no. (e) (f) (g)
4204-4216	Bolt, 100°, close-tolerance, long thread, Tri-wing recess, self-locking and non-locking	W	1/4 - 1 in	CRS (c)	B	U = unplated D,L or P see (g)	-	X and Y as 4104	NAS No. + dash no. (e) (f) (g)
4304-4316	Bolt, 100°, long thread, Tri-wing recess, self-locking and non-locking	W	1/4 - 1 in	Titanium (d)	B	U = unplated D,L or P see (g)	-	X and Y as 4104	NAS No. + dash no. (e) (f) (g)

Table 11 NAS Bolts and Screws (Continued)

NAS No.	Type	Head (Fig.5)	Size Range	Material	Coding				Head Marking
					Dia.	Replacing Dash or First Dash	Replacing Second Dash	At End	
4400-4416	Bolt, 100°, short thread, Tri-wing recess, self-locking and non-locking	W	No.4 - 1 in	Alloy steel	B	B = black plating D,L or P see (g)	-	X and Y as 4104	NAS No. + dash no. (e) (f) (g)
4500-4516	Bolt, 100°, close-tolerance, short thread, Tri-wing recess, self-locking or non-locking	W	No.4 - 1 in	CRS (c)	B	U = unplated D,L or P see (g)	-	X and Y as 4104	NAS No. + dash no. + C for CRS (e) (f) (g)
4600-4616	Bolt, 100°, close-tolerance, short thread, Tri-wing recess, self-locking and non-locking	W	No.4 - 1 in	Titanium (d)	B	U = unplated D,L or P see (g)	-	X and Y as 4104	NAS No. + dash no. + V for titanium (e) (f) (g)
4703-4716	Bolt, 100°, close-tolerance, short thread, reduced head, non-locking, Tri-wing recess	W	No.10 - 1 in	Alloy steel	B	D = drilled shank Nil = undrilled	-	X and Y as 4104	NAS No. + dash no. (e) (f)
4803-4816	Bolt, 100°, close-tolerance, short thread, reduced head, non-locking, Tri-wing recess	W	No.10 - 1 in	CRS (c)	B	D = drilled shank U = unplated	-	X and Y as 4104	NAS No. + dash no. + C for CRS (e) (f)

Table 11 NAS Bolts and Screws (Continued)

NAS No.	Type	Head (Fig.5)	Size Range	Material	Coding				Head Marking
					Dia.	Replacing Dash or First Dash	Replacing Second Dash	At End	
4903-4916	Bolt, 100°, close-tolerance, short thread, reduced head, non-locking, Tri-wing recess	W	No.10 - 1 in	Titanium (d)	B	D = drilled shank U = unplated	-	X and Y as 4104	NAS No. + dash no. + V for titanium (e) (f)
5000-5006	Bolt, pan head, close-tolerance, short thread, Tri-wing recess, self-locking and non-locking	X	No.4 - ³ / ₈ in	Alloy steel	B	B = black plating L or P see (g)	-	X and Y as 4104	NAS No. + dash no. (e) (f) (g)
5100-5106	Bolt, pan head, close-tolerance, short thread, Tri-wing recess, self-locking and non-locking	X	No.4 - ³ / ₈ in	CRS (c)	B	U = unplated L or P see (g)	-	X and Y as 4104	NAS No. + dash no. + C for CRS (e) (f) (g)
5200-5206	Bolt, pan head, close-tolerance, short thread, Tri-wing recess, self-locking and non-locking	X	No.4 - ³ / ₈ in	Titanium (d)	B	U = unplated L or P see (g)	-	X and Y as 4104	NAS No. + dash no. + V for titanium (e) (f) (g)
5300-5360	Screw, flat fillister head, full thread, Tri-wing recess, self-locking and non-locking	Y or Z	No.4 - ³ / ₈ in	Alloy steel	B	H = drilled head B = black plating L or P see (g)	-	-	NAS No. + dash no. (f) (g)

Table 11 NAS Bolts and Screws (Continued)

NAS No.	Type	Head (Fig.5)	Size Range	Material	Coding				Head Marking
					Dia.	Replacing Dash or First Dash	Replacing Second Dash	At End	
5400-5406	Screw, flat fillister head, full thread, Tri-wing recess, self-locking and non-locking	Y or Z	No.4 - 3/8 in	CRS (c)	B	H = drilled head U = unplated L or P see (g)	-	-	NAS No. + dash no. + C for CRS (f) (g)
5500-5506	Screw, flat fillister head, full thread, Tri-wing recess, self-locking and non-locking	Y or Z	No.4 - 3/8 in	Titanium (d)	B	H = drilled head U = unplated L or P see (g)	-	-	NAS No. + dash no. + V for titanium (f) (g)
5600-5606	Screw, 100°, full thread, Tri-wing recess, self-locking and non-locking	W	No.4 - 3/8 in	Alloy steel	B	B = black plating L or P see (g)	-	-	NAS No. + dash no. (f) (g)
5700-5706	Screw, 100°, full thread, Tri-wing recess, self-locking and non-locking	W	No.4 - 3/8 in	CRS (c)	B	B = black plating U = unplated L or P see (g)	-	-	NAS No. + dash no. + C for CRS (f) (g)
5800-5806	Screw, 100°, full thread, Tri-wing recess, self-locking and non-locking	W	No.4 - 3/8 in	Titanium (d)	B	U = unplated L or P see (g)	-	-	NAS No. + dash no. + V for titanium (f) (g)

Table 11 NAS Bolts and Screws (Continued)

NAS No.	Type	Head (Fig.5)	Size Range	Material	Coding				Head Marking
					Dia.	Replacing Dash or First Dash	Replacing Second Dash	At End	
6000-6003	Screw, hex.head, full thread, Tri-wing recess	V	No.4 to No.10	CRS (c)	B	U = unplated	-	-	NAS No. + dash no + C for CRS (f)
6100-6103	Screw, hex.head, full thread, Tri-wing recess	V	No.4 to No.10	Titanium (d)	B	U = unplated	-	-	NAS No. + dash no. + V for titanium
6203-6220	Bolt, hex.head, short thread, close-tolerance, self-locking and non-locking	C or K	No.10 - 1 ¼ in	Alloy steel	B	D,L or P see (g)	-	X or Y as 4104 D = drilled shank H = drilled head	NAS No. + dash no. (e) (g)
6303-6320	Bolt, hex. head, short thread, close-tolerance, self-locking or non-locking	C or K	No.10 - 1 ¼ in	CRS (c)	B	U = unplated L or P see (g)	-	X or Y as 4104 D = drilled shank H = drilled head	NAS No. + dash no. (e) (g)
6403-6420	Bolt, hex.head, short thread, close tolerance, self-locking or non-locking	C or K	No.10 - 1 ¼ in	Titanium (d)	B	U = unplated L or P see (g)	-	X or Y as 4104 D = drilled shank H = drilled head	NAS No. + dash no. (e) (g)
6604-6620	Bolt, hex.head, long thread, close-tolerance, self-locking and non-locking	C or K	¼ - 1 ¼ in	Alloy steel	B	D = drilled shank H = drilled head L or P see (g)	-	X or Y as 4104	NAS No. + dash no. (e) (g)

Table 11 NAS Bolts and Screws (Continued)

NAS No.	Type	Head (Fig.5)	Size Range	Material	Coding				Head Marking
					Dia.	Replacing Dash or First Dash	Replacing Second Dash	At End	
6704-6720	Bolt, hex.head, long thread, close-tolerance, self-locking and non-locking	C or K	¼ - 1 ¼ in	CRS (c)	B	D = drilled shank H = drilled head U = unplated L or P see (g)	-	X or Y as 4104	NAS No. + dash no. (e) (g)
6804-6820	Bolt, hex.head, long thread, close-tolerance, self-locking and non-locking	C or K	¼ - 1 ¼ in	Titanium (d)	B	D = drilled shank H = drilled head U = unplated L or P see (g)	-	X or Y as 4104	NAS No. + dash no. (e) (g)

NOTE:

- a) For repair work only, replacing NAS 1503 to 1510.
- b) For repair work only.
- c) Cadmium plated CRS bolts have green dye or paint on the end of the shank.
- d) Cadmium plated titanium bolts have red dye or paint on the end of the shank.
- e) Oversize bolts are marked with 'X' or 'Y' (see code).
- f) Heads are also marked with an encircled number, to indicate the size of the Tri-wing recess, in accordance with NAS 4000.
- g) Method of locking, included in code and marked on head, is as follows:
D = drilled shank. L = locking element is optional. P = patch type locking element.

5.4 **Examples of Coding**

- a) NAS 564–15 is a full-threaded bolt in cadmium-plated alloy steel, with $\frac{1}{4}$ –28 thread, and length of $\frac{15}{32}$ in.
- b) NAS 1146E12P is a screw with a modified pan head, close-tolerance shank and Torq-Set recess, made from CRS (160 000 lbf/in²), with Type II plating. It has a $\frac{3}{8}$ –24 thread and a $\frac{3}{4}$ in grip length.
- c) NAS 1189–3T8L is a self-locking screw with a 100° countersunk head and full thread. It has a 10–32 thread, is $\frac{1}{2}$ in long, and is in alloy steel with Type II plating. It has a strip-type nylon locking element and a Torq-Set recess.
- d) NAS 6804D10X is a hexagon head, close-tolerance bolt in titanium alloy, with a long thread. It has a $\frac{1}{4}$ –28 thread and $\frac{5}{8}$ in grip length, and a drilled shank which is 0.0156 in oversize.

Chapter F Non-destructive Examinations

Leaflet F-10 Oil and Chalk Processes

1 Introduction

- 1.1 This Leaflet provides guidance and advice on the detection of surface defects, such as cracks and porosity, by processes involving the use of oil and chalk. The principle which the process is based upon, is the absorption by chalk of fluids. A penetrant oil is applied to the surface of the parts to be checked and, after removing the surplus oil, a layer of chalk is applied. Oil entrapped in defects is absorbed by the chalk, the resulting stains indicating their position.
- 1.2 There are two basic methods of applying the process, i.e. the 'Hot Fluid Process' and the 'Cold Fluid Process'. Of these, the process employing hot oil is the more efficient and should be used wherever possible, but both methods suffer serious limitations, as indicated in paragraph 2. However, some proprietary processes, e.g. the 'Bristol Modified Method of Oil and Chalk Test', which is an adaptation of the hot fluid process, are not subject to such deficiencies. The Bristol Modified Method is considered in more detail in paragraph 5.
- 1.3 Guidance on the use of penetrant dye and fluorescent ink processes, which have largely superseded the conventional oil and chalk processes, is given in CAAIP Leaflet F-20. Information on the use of ultrasonic equipment for the detection of flaws is given in CAAIP Leaflet F-30, and on the radiological examination of aircraft structures in CAAIP Leaflet F-40. Guidance on magnetic methods of flaw detection is given in CAAIP Leaflet F-50.

2 Limitations of the Processes

- 2.1 The oil and chalk processes were devised for the detection of surface defects in non-ferrous and some non-metallic materials, but the deficiencies described in the following paragraphs should be considered before deciding upon the suitability of either of the processes for the work in hand. The processes are not considered suitable for the detection of minute flaws or tightly shut cracks.
- 2.2 The processes are quite effective for such applications as the detection of large cracks in rough castings, but in general, the degree of contrast obtained by oil exudation is very poor and, unless the pre-cleaning and final drying processes are efficiently done, spurious indications of defects may be given.
- 2.3 Defect indications, at best, will appear only as dark grey stains on a light grey background, and are not sufficiently defined to make the detection of small cracks practicable, particularly when examining parts having dark surfaces, e.g. chromated magnesium alloy parts.
- 2.4 When the hot oil process is used for parts which are dimensionally large or are of intricate shape, it is often not possible to remove the surplus oil quickly enough to be able to apply the chalk before the parts become cool, thus the object of heating is defeated (see paragraph 3.4). On the other hand, if the drying is not done efficiently,

masking of defects may occur due to the spontaneous staining of the chalk in damp areas.

3 Hot Fluid Process

- 3.1 To obtain satisfactory results it is essential that the parts should be thoroughly cleaned before immersion. If the parts have previously been immersed in an acid pickle bath, paint stripper, or some other strong solution, all traces of such solutions must be removed by adequate washing to avoid contamination of the test oil.
- 3.2 The parts to be examined should be immersed or (if a specified area only is to be examined) partly immersed, in a solution consisting of approximately 28% (by volume) of lard oil in paraffin. The solution should be maintained at a temperature of approximately 80°C, and the period of immersion must be sufficient to allow the parts to attain this temperature. If preferred, solutions consisting of three parts paraffin and one part lubricating oil, or 50% paraffin and 50% spindle oil, may be used.
- 3.3 After immersion the parts should be dried quickly and thoroughly with a non-fluffy rag; excellent final cleaning can be achieved by the use of unglazed tissue paper.
- 3.4 The parts should then be placed in the chalk cabinet and a fine layer of dry powdered French chalk should be applied, preferably by a method that will distribute the chalk in a gentle cloud. A paint spray gun with a conical funnel fitted in front of the jet, operated at a pressure of about 0.70 kg/sq cm (10 lb/sq in), will be found suitable for this purpose. The gun should be provided with an efficient water trap. Surplus chalk should be removed by lightly tapping the parts on a block of wood.
- NOTE:** The chalk cabinet should form an enclosed area in which the parts to be examined can be placed. It should have a transparent front and should be fitted with an exhaust fan to remove surplus chalk. The parts can be coated more rapidly if a turntable is used.
- 3.5 The parts should be inspected for defects when quite cool and it will be found that if any cracks are present, the fluid will have been forced from them as the metal contracted on cooling, causing the chalk to become stained. A gentle air stream from a source pressurised at not more than 0.70 kg/sq cm (10 lb/sq in), if directed on to the surfaces of the parts, may assist in the revelation of defects by removing the adjacent unstained chalk. It is essential that the examination should be made with the aid of a strong light.

4 Cold Fluid Process

- 4.1 As stated in paragraph 1.2, the efficiency of this process is not equal to that of the hot fluid process, and it should be used only where the application of the latter process would not be practicable, e.g. when examining parts of assembled structures or parts too large for immersion.
- 4.2 The parts should be thoroughly cleaned and then coated with a solution of lard oil and paraffin, or lubricating oil and paraffin, in the proportions recommended in paragraph 3.1. After the surfaces to be examined have been thoroughly coated, all traces of the solution should be removed with a non-fluffy rag, followed by final wiping with unglazed tissue paper. The surface should then be coated with French chalk (paragraph 3.4).
- 4.3 Any oil entrapped in defects will be drawn out by the absorbent chalk, the resulting stains indicating the position of the defects. It is essential that the examination should be made with the aid of a strong light.

5 The Bristol Modified Method

- 5.1 In this process, finished parts or rough castings are immersed in hot oil, are removed and have the surfaces degreased, and are then sprayed or dusted with dry French chalk.
- 5.2 The parts to be examined should be immersed or (if a specified area only is to be examined) partly immersed, in a solution consisting of 50% paraffin and 50% spindle oil. The solution must be maintained at a temperature of 70°C and the period of immersion should be sufficient to allow the parts to attain this temperature, one hour usually being sufficient.
- 5.3 After immersion, the parts should be allowed to stand until all surplus oil has drained off, after which they should be transferred to a degreasing tank containing a solution consisting of the following:

Teepol	5%	} by volume
Cresylic Acid	5%	
Water	90%	

The solution should be maintained at a temperature of between 70°C to 80°C. When the cleansing action deteriorates, additions of Teepol and cresylic acid should be made to restore the above proportions.

NOTE: The cresylic acid should comply with the requirements of British Standard 524, Grades A or B.

- 5.4 The parts should be immersed in the degreasing solution for 3 to 5 minutes and should be agitated throughout this period.
- 5.5 After degreasing, the parts should be transferred to a tank containing clean hot water, and should be thoroughly swilled for a period of from 3 to 5 minutes, after which they should be allowed to drain.
- 5.6 When dry, the parts should be coated with a layer of dry French chalk, the equipment described in paragraph 3.3 being suitable for this purpose, except that an air pressure of 4.22 to 5.63 kg/sq cm (60 to 80 lb/sq in) is recommended, after which surplus chalk should be removed by the application of a jet of air at about 1.75 to 2.11 kg/sq cm (25 to 30 lb/sq in) pressure.
- 5.7 The parts should now be examined for defects, and cracks will be indicated by a thin white line of chalk.

INTENTIONALLY LEFT BLANK

Leaflet F-20 Penetrant Dye Processes

1 Introduction

- 1.1 This Leaflet provides guidance and advice on the penetrant dye processes used for the detection of defects which break the surface of the part, such as cracks, cold shuts, folds, laps and porosity.
- 1.2 Penetrant dye processes are used mainly for the detection of flaws in non-ferrous and non-magnetic ferrous alloys but may also be used for ferrous parts where magnetic flaw detection techniques are not specified or are not possible. However, in some instances both penetrant dye and magnetic flaw detection techniques may be specified for a particular part (see paragraph 1.6.5). Penetrant dyes may also be used on some non-metallic materials but their use with transparent acrylic-type materials is not recommended, since crazing may result.
- 1.3 Although the processes are usually marketed under brand names, those used on aircraft parts for which a penetrant process of flaw detection is a mandatory requirement must comply with the requirements of Process Specification DTD 929. It must be ensured that any storage limiting period prescribed by the manufacturer of the process is not exceeded.
- 1.4 The processes available can be divided into two main groups. One group involves the use of penetrants containing an emulsifying agent (termed water-emulsifiable or water-washable processes) whilst in the other group a dye solvent has to be applied separately after the penetration time (paragraph 4) has elapsed if the surplus dye is to be removed by a water-wash operation. The processes may be further sub-divided inasmuch that with some processes the use of a dry developer is recommended whilst with others a wet developer is used. The manufacturers' recommendations and instructions for each individual process must be followed carefully to ensure satisfactory results. Reference should also be made to Leaflet F-40 Performance Testing of Penetrant Testing Materials, to ensure that the penetrant materials used are in a satisfactory condition.

NOTE: An emulsifier is a blending of wetting agents and detergents which enables excess dye to be removed with water and, in the case of wide flaws, assists in preventing the dye seeping out too quickly.

- 1.5 Basically all the processes consist of applying a red penetrant dye to the surface of the part to be tested, removing after a predetermined time the dye which remains on the surface and then applying a developer, the purpose of which is to draw to the surface any dye that has entered into defects, the resultant stains indicating the positions of the defects.
- 1.6 **Penetrant Processes**
- 1.6.1 The selection of the most suitable type of penetrant process e.g. penetrant dye or fluorescent penetrant with or without post-emulsification (see Leaflet F-30), for any given application must largely be governed by experience, since when used correctly a high degree of efficiency can be obtained with any of the processes. Guidance on some of the factors which should be given consideration is provided in the following paragraphs.
- 1.6.2 Within a given type of process, the post-emulsification method is generally considered to be the most sensitive and is usually selected for finished machined parts and for the detection of 'tight' defects. However, its use on rougher surfaces

(e.g. castings) may be less effective than would be the use of a penetrant containing an emulsifier, since it may pick up the surface texture of the material, thus rendering the detection of actual defects more difficult.

- 1.6.3 Where large heavy parts are concerned, and particularly where mechanical handling is involved, the use of penetrant dyes may be more practicable than that of fluorescent penetrants, since the necessity of darkening a relatively large area before the examination can be made does not arise.
- 1.6.4 When making 'in situ' checks on aircraft, the use of penetrant dyes may be more suitable where there is sufficient light but in darker areas a fluorescent process may provide better definition of defects.
- NOTE:** Battery-operated ultra-violet light sources are now available.
- 1.6.5 With steel castings for example, porosity may be detected more readily by a penetrant process than by a magnetic flaw detection technique (Leaflet F-70) and for this reason the application of both processes is sometimes specified. If the magnetic flaw detection test precedes the penetrant test, great care will be necessary with the intervening degreasing process to ensure that all traces of the magnetic testing medium are removed, otherwise the subsequent penetrant test may be unsuccessful.
- 1.7 Some of the materials associated with penetrant testing have low flash points and the appropriate fire precautions should be taken.

2 Surface Preparation

- 2.1 The major reason for the failure of penetrant processes to provide indications of defects is incorrect or inadequate surface cleaning. For example, embedded extraneous matter can seal off cracks, etc., whilst contaminants remaining on the surface can trap the dye and give rise to false indications or, more detrimentally, obscure genuine defects. Thus the surface to be tested must be free from oil, grease, paint, rust, scale, welding flux, carbon deposits, etc., and the method of cleaning should be selected with the intention of removing extraneous matter from within the defects as well as from the surface to permit maximum dye penetration.
- 2.2 On unmachined steel stampings and forgings it may be necessary to remove rust or scale by sandblasting and to prepare aluminium alloy forgings by light sandblasting. However, the use of such processes must be given careful consideration, since they may result in the filling or 'peening-over' of defects. Generally, unless specified otherwise, aluminium alloy forgings should be prepared by a suitable pickling process (e.g. by one of the methods prescribed in Process Specification DTD 901).
- 2.3 Magnesium alloy castings should be tested after chromating in order to reduce the risk of corrosion, but the requirements of Process Specification DTD 911, with regard to surface protection, must be taken into account and a suitable sequence devised.
- 2.4 Where contamination is mainly of an organic nature, degreasing by the trichloroethylene process (unless there are instructions to the contrary) is usually suitable. However, not all types of trichloroethylene are suitable for use with titanium alloys. The cleaning of titanium alloys by methanol should be avoided.
- 2.5 Where parts have to be tested 'in situ', the use of volatile solvents (e.g. carbon tetrachloride) as cleaning agents should be given consideration. Where paint is present, this should be removed from the surface to be tested prior to cleaning. Subsequent to the test, the surface should be reprotected in the prescribed manner.

NOTE: Suitable fire precautions must be taken when flammable materials are used.

- 2.6 Sufficient time should be allowed after cleaning for drying out, otherwise the efficiency of the penetrant dye may be affected. The time interval allowed for the evaporation of solvents can only be determined by the prevailing conditions of temperature and humidity and the type of solvent used.

3 Application of the Dye

- 3.1 The penetrant dye can be applied to the surface by dipping, spraying or brushing, the method used depending largely on the size, shape and quantity of the parts to be examined. The surface must be dry before the dye is applied. Even the condensation which forms on a cold surface in humid conditions may interfere with dye penetration; in such conditions the part should be warmed to a temperature of about 32°C to 38°C (90°F to 100°F) but temperatures in excess of 60°C (140°F) must be avoided, since these may result in the volatilisation of some of the lighter constituents of the dye.

3.2 Dipping Method

- 3.2.1 Dipping should generally be used where large numbers of small parts are to be examined. The parts must be completely dried before immersion, since apart from affecting penetration, water or solvents will contaminate the dye.

- 3.2.2 During dipping care must be taken to ensure that the parts are so racked that air pockets are avoided and all surfaces to be examined are completely wetted by the dye.

- 3.2.3 It is not necessary for the parts to remain submerged in the tank during the penetration time (see paragraph 4) but only for a period sufficient to permit thorough wetting. 'Drag-out' losses can be reduced if the dye is allowed to drain back into the tank during the penetration time.

- 3.3 **Flooding Method.** The flooding method should generally be used where large areas are to be examined. The dye should be applied with low-pressure spray equipment which will not permit atomisation of the fluid, any surplus dye being allowed to drain back into the tank.

- 3.4 **Aerosol Can Method.** Penetrant contained in Aerosol type cans is often used for 'in situ' inspections. The best results are obtained when the can is held about 12 inches from the surface under test.

- 3.5 **Brushing Method.** The brushing method is generally used for individual items and items of complicated shape. A clean soft bristle brush should be used and retained only for this purpose.

4 Penetration Time

- 4.1 The penetration time is the time which has to be allowed for the dye to penetrate effectively into the defects. It is dependent upon a number of factors, such as the characteristics of the process being used, the material from which the part is made, the size and nature of the defects being sought, the processes to which the part has been subjected and the temperatures of the atmosphere, the part and the dye. Clearly the time can be decided only by experience of the particular local conditions but is usually in the range of 5 minutes to 1 hour, the smaller the defect the longer the time necessary.

- 4.2 Temperatures below 15°C (60°F) will retard the penetrant action of the dye, thus the penetration time should be extended proportionately. Testing in temperatures at or

near freezing point should, if possible, be avoided, since in such conditions the performance of the penetrant is considerably reduced.

- 4.3 Where the effectiveness of the pre-cleaning process cannot be guaranteed or where parts have been sandblasted, the penetration time should be extended but it should be borne in mind that this is no guarantee that defects will, in fact, be revealed in such conditions.

5 Removal of Excess Dye

- 5.1 Any dye remaining on the surfaces of the parts after expiry of the penetration time should be removed as thoroughly as possible but without disturbing the dye which would have found its way into any defects present. Excessive cleaning, however, may result in the dilution of the dye or its complete removal from defects. The method of removal depends on whether a water-washable or post-emulsifiable dye was used and the size and condition of the surface under test.

- 5.2 **Water-washable Dye.** Water-washable dye should be removed as indicated in the following paragraphs.

- a) The dye should be removed from 'in situ' parts with clean rags saturated in water, followed by wiping with clean rags until the surfaces are both dry and free from dye.
- b) The dye should be removed from small parts with clean rags saturated in water, followed by drying as recommended in paragraph 5.3.
- c) The dye should be removed from large areas or irregularly shaped parts by flushing with an aerated spray of water, followed by drying as recommended in paragraph 5.3.

- 5.3 **Post-emulsifiable Dye.** Post-emulsifiable dye should be removed from small areas and 'in situ' parts first by wiping with clean rag dampened with dye solvent, followed by wiping or blotting with a clean dry rag. The bulk of the dye may be removed from large areas, irregularly-shaped parts and rough-textured surfaces by a quick water wash (allowing this to drain) followed by the application of the dye solvent and a final water wash. The dye solvent should be applied by spraying, swabbing, dipping or brushing, except that brushing should not be used where relatively large defects are suspected. Washing should be followed by thorough drying, as outlined in paragraph 5.4.

5.4 Surface Drying

- 5.4.1 Prior to applying the developer (paragraph 6) it should be ensured that the surfaces of the part under test are completely dry. The following methods of surface drying are recommended which, although slower than the use of, for example, compressed air, are less likely to disturb entrapped dye.
- 5.4.2 Small areas may be wiped dry but since this may disturb the dye in the wider defects, the use of warm air is preferred.
- 5.4.3 Hot-air ovens and similar equipment may be used for drying, a temperature of about 54°C (130°F) being suitable; temperatures in excess of 79°C (175°F) must be avoided. The use of lamps for drying is not recommended unless uniform heat application can be guaranteed.

6 Application of the Developer

- 6.1 The developer usually consists of a very fine absorbent white powder which may be applied in
- a) the form of a spray, the powder being suspended in a volatile carrier liquid which rapidly evaporates, leaving a white coating on the surface,
 - b) as a dip with the powder suspended in water or
 - c) as a dry powder which may be blown on to the component or into which the component may be dipped. The action of the absorbent powder is to draw out the dye from the surface defects, thus indicating their position by the resulting stain.
- 6.2 Where it is suspected that microscopic defects may be present, great care is necessary to ensure that the developer is applied evenly and very thinly, since a thick layer might conceal completely a defect holding only a minute quantity of dye.
- 6.3 Where a wet developer is concerned, the best results are obtained when the developer is applied by means of a paint-type spray gun operating at an air pressure not in excess of 1.0554 kg/sq cm (15 lb/sq in). The pressure pot of the spray gun should be equipped with a stirrer to keep the developer agitated and the absorbent particles in suspension. Before pouring the developer into the spray gun it should be well shaken to ensure a thorough distribution of the absorbent particles.
- 6.4 When requirements are not too exacting, small parts can be dipped into a bath of developer but the action must be performed rapidly to minimise the possibility of the dye being washed out of shallow defects. The bath should be agitated from time to time to ensure that the absorbent particles are kept in uniform suspension. The formation of pools of developer on the parts during draining must be avoided, otherwise the resultant thick coatings may mask defects.
- 6.5 Due to the usually uneven results obtained, the use of a brush for applying the developer is not recommended.
- 6.6 If the developer dries with a slightly pinkish hue, this is probably due to faulty cleaning or 'carried over' penetrant in the penetrant remover (see paragraph 7.3) but provided sufficient contrast remains to enable minute defects to be detected, the condition is acceptable.
- 6.7 Water must not be permitted to enter the developer containers, since its presence will retard considerably the drying rate of the developer.

7 Interpretation of Defects

- 7.1 If defects are present and all stages of the process have been applied correctly, the position of the defects will be indicated by red marks appearing on the whitened surface. The majority of defects are revealed almost immediately the developer dries but additional time (approximately equal to the penetration time (paragraph 4)) should be allowed for 'tight' flaw indications to appear and for flaw patterns to reach their final shape and size (Figure 1).
- 7.2 By noting and comparing the indications that appear during the first 30 seconds of development with those which exist after about 10 minutes, a more accurate assessment of the characteristics of the defects is possible. For example, the dye exuding from a shallow crack is little more after 10 minutes than after 30 seconds but in the case of a deep narrow crack, considerably more dye is present, causing a much wider indication to develop over a similar period of time. Thus the rate of staining is

an indication of the width and depth of the defect, whilst the extent of staining is an indication of its volume.



Figure 1 Indications given by Defects

- 7.3 Scattered dots of dye indicate fine porosity or pitting (Figure 1(d)) whilst gross porosity may result in an entire area becoming stained. Where doubt exists as to whether the overall pinkish effect is due to inadequate washing, the process should be repeated, more care being taken particularly during the stage of cleaning off the excess dye.
- 7.4 Closely spaced dots in a line or curved pattern (Figure 1(c)) usually indicate tight cracks or laps but such patterns are also characteristic of very wide defects from out of which most of the dye has been washed. Wide cracks, lack of fusion in welded parts and other similar defects are indicated by continuous lines as shown in Figures 1(a) and 1(b).
- 7.5 Examination by means of a powerful magnifying glass is often useful when minute defects are being sought.
- 7.6 All defects should be suitably marked prior to removing the developer, but crayons should not be used on highly-stressed components subject to heat treatment, since this is known to induce fractures.

8 Removal of Developer

Developer can be removed by brushing or by air or water under pressure, but since the surface is then in a condition susceptible to corrosion (where this is applicable) the prescribed protective treatment should be applied with the minimum of delay. It should be noted that the adhesion of paints and resins may be seriously impaired by certain oil-base dyes if thorough cleaning is not ensured.

9 Leak Testing with Penetrant Dyes

- 9.1 On components or assemblies where the main purpose of the test is to locate defects which would result in a fluid leakage (e.g. cracks in pressure vessels) the methods of testing described in the previous paragraphs may not be conclusive. In such cases the inner and outer surfaces should be thoroughly cleaned and degreased, the dye being applied to one surface (usually the inside of pressure vessels) and the

developer to the other. After the penetration time (paragraph 4) has elapsed, the surface should be inspected for evidence of staining.

- 9.2 Where no definite penetration time has been determined then, with a wall thickness of from 1.5 mm (0.0625 in) to 3 mm (0.125 in), the penetration time should be at least three times that which would be allowed for a standard 'one-side-only' test.
- 9.3 More than one application of the dye is often required and as a general rule an additional application for each 1.5 mm (0.0625 in) to 3 mm (0.125 in) wall thickness is recommended.

INTENTIONALLY LEFT BLANK

Leaflet F-30 Fluorescent Penetrant Processes

1 Introduction

- 1.1 This Leaflet gives guidance on the fluorescent penetrant processes used for the detection of defects in a component, such as cracks, cold shuts, folds, laps and porosity when these break the surface of the component.
- 1.2 Fluorescent penetrant processes are used mainly for the detection of flaws in non-ferrous and non-magnetic ferrous alloys but may also be used for ferrous parts where magnetic flaw detection techniques are not specified or are not possible. In some instances both fluorescent penetrant and magnetic flaw detection techniques may be specified for a particular part (see paragraph 1.6.4). Fluorescent penetrants may also be used on some non-metallic materials, such as plastics and ceramics, but in each case a suitable process for the particular material must be selected. The processes are not suitable for use on absorbent materials.
- 1.3 Although the processes are usually marketed under brand names, those used on aircraft parts for which a penetrant process of flaw detection is a mandatory requirement must comply with the requirements of Process Specification DTD 929. It must be ensured that any storage limiting period prescribed by the manufacturer of the process is not exceeded.
- 1.4 There are two types of fluorescent penetrants, a minor water-based group and a major oil-based group; the manufacturers of the processes usually specify the materials for which each process is suitable. There are variations in the processes which must be taken into account. For example, some types of penetrants contain an emulsifier, whilst in other processes the penetrant and the emulsifier are applied as separate stages. Again in some processes the use of a dry developer is recommended whilst in others a wet developer is used. The manufacturer's recommendations and instructions for each individual process must be followed carefully to ensure satisfactory results.
- NOTE:** An emulsifier is a blending of wetting agents and detergents which enables excess penetrant to be removed with water.
- 1.5 Fluorescent penetrant testing is based on the principle that when ultra-violet radiation falls on certain chemical compounds (in this case the penetrant) it is absorbed and its energy is re-emitted as visible light (i.e. the wavelength of the light is changed). Thus, if a suitable chemical is allowed to penetrate into surface cavities, the places where it is trapped and has been drawn to the surface by the developer will be revealed by brilliant greenish-yellow lines or patches (according to the nature of the defect) under the rays of an ultra-violet lamp.
- 1.6 The selection of the most suitable type of penetrant process (e.g. penetrant dye (Leaflet F-20) or fluorescent penetrant; with or without post-emulsification) for any given application must largely be governed by experience, since when correctly used a high degree of efficiency can be obtained with any of the processes. Guidance on some of the factors which should be given consideration is provided in the following paragraphs.
- 1.6.1 Within a given type of process, the post-emulsification method is generally considered to be the most sensitive and is usually selected for finished machined parts and for the detection of 'tight' defects. However, its use on rougher surfaces (e.g. castings) may be less effective than would be the use of a penetrant containing

an emulsifier, since it may pick up the surface texture of the material, thus rendering the detection of actual defects more difficult.

- 1.6.2 Where large, heavy parts are concerned, and particularly where mechanical handling is involved, the use of penetrant dyes may be more practicable than that of fluorescent penetrants, since the necessity of darkening a relatively large area before the examination can be made does not arise.
- 1.6.3 When making 'in situ' checks on aircraft, the use of penetrant dyes may be more suitable where there is sufficient light but in the darker areas a fluorescent process may provide better definition of defects.
- 1.6.4 With steel castings, for example, porosity may be detected more readily by a penetrant process than by the magnetic flaw detection techniques (Leaflet F-50) and for this reason the use of both processes is sometimes specified. If the magnetic flaw detection test precedes the penetrant test, great care will be necessary with the intervening degreasing process to ensure that all traces of the magnetic testing medium are removed, otherwise the subsequent penetrant test may be unsuccessful.
- 1.7 Some of the materials associated with penetrant testing have low flash points and the appropriate fire precautions should be taken.
- 1.8 Guidance on dye penetrant processes is given in Leaflet F-20. Information on the performance testing of penetrant testing materials is given in Leaflet F-40.

2 Surface Preparation

The major reason for the failure of penetrant processes to provide indications of defects is incorrect or inadequate surface cleaning. For example, embedded extraneous matter can seal off cracks, etc., whilst contaminants remaining on the surface can trap the penetrant and give rise to false indications or, more detrimentally, obscure genuine defects. Thus the surface to be tested must be free from oil, grease, paint, rust, scale, welding flux, carbon deposits, etc., and the method of cleaning selected must be capable of removing extraneous matter from within the defects as well as from the surface to permit the maximum penetration.

- 2.1 With unmachined steel stampings and forgings it may be necessary to remove rust or scale by sandblasting. Aluminium alloy forgings may also need light sandblasting. However, the use of such processes must be given careful consideration, since they may result in the filling or 'peening-over' of defects. Generally, unless specified otherwise, aluminium alloy forgings should be prepared by a suitable pickling process (e.g. by one of the methods prescribed in Process Specification DTD 901).
- 2.2 Magnesium alloy castings should be tested after chromating in order to reduce the risk of corrosion, but the requirements of Process Specification DTD 911, with regard to surface protection, must be taken into account and a suitable sequence devised.
- 2.3 Where contamination is mainly of an organic nature, degreasing by the trichloroethylene process (unless there are instructions to the contrary) is usually suitable. However, not all types of trichloroethylene are suitable for use with titanium alloys. The cleaning of titanium alloys by methanol should be avoided.
- 2.4 Where parts have to be tested 'in situ', the use of volatile solvents (e.g. carbon tetrachloride) as cleaning agents should be given consideration. Where paint is present this should be removed from the surface to be tested prior to cleaning. Subsequent to the test, the surface should be reprotected in the prescribed manner.

NOTE: Suitable fire precautions must be taken where flammable materials are used.

- 2.5 Sufficient time should be allowed after cleaning for drying-out, otherwise the efficiency of the penetrant may be affected. The time interval allowed for the evaporation of solvents can only be determined by the prevailing conditions of temperature and humidity and the type of solvent used.

3 Application of the Penetrant Process (without Post Emulsification)

- 3.1 **Application of Penetrant.** The penetrant can be applied to the surface by dipping, spraying or brushing, the method used depending largely on the size, shape, and quantity of the parts to be examined. The surface must be dry before the penetrant is applied. Even the condensation which forms on a cold surface in humid conditions may interfere with penetration; in such conditions the part should be warmed, preferably within the temperature range of 21°C (70°F) to 32°C (90°F).

- 3.1.1 **Dipping Method.** Dipping should generally be used where large numbers of small parts are to be examined. The parts must be completely dried before immersion, since apart from affecting penetration, water or solvents will contaminate the penetrant.

a) During dipping care must be taken to ensure that the parts are so racked that air pockets are avoided and all surfaces to be examined are completely wetted by the penetrant.

b) The parts should be dipped for a few seconds and allowed to drain, care being taken to ensure that the solution is able to drain away from any pockets or cavities in the parts. If there is a tendency for the penetrant to dry on the surfaces the parts should be redipped.

- 3.1.2 **Flooding Method.** The flooding method should generally be used where large areas are to be examined. The penetrant should be applied with low-pressure spray equipment which will not permit atomisation of the fluid, care being taken to ensure that the penetrant completely covers the surface and remains wet. On no account should the penetrant be allowed to dry during the penetration period (paragraph 3.2).

- 3.1.3 **Aerosol Method.** Penetrant contained in aerosol-type cans is often used for 'in situ' inspections. The best results are obtained when the can is held about 30 cm (12 in) from the surface under test.

- 3.1.4 **Brushing Method.** The brushing method is generally used for individual items and items of complicated shape. A soft clean bristle brush should be used and retained only for this purpose. On no account should the penetrant be allowed to dry during the penetration period.

- 3.2 **Penetration Time.** The penetration time is the time which has to be allowed for the penetrant to enter effectively into defects and usually a period of up to 10 minutes is sufficient for the larger type defects, but longer times may be necessary where minute defects are being sought. (See Table 1).

- 3.2.1 Typical penetration times are given in Table 1 but these may vary according to the temperature and process used. The manufacturer's recommendations must always be followed where these differ from the figures given.

- 3.2.2 Where the effectiveness of the pre-cleaning process cannot be guaranteed or where parts have been sandblasted, the penetration time should be extended but it should be borne in mind that this is no guarantee that defects will, in fact, be revealed in such conditions.

Table 1

Material	Nature of Defect	Penetration Time (Minutes)
Sheets and Extrusions	Heat treatment cracks, grinding cracks and fatigue cracks.	15
Forgings	Laps, Cracks.	30
Castings	a) Shrinkage, cracks and porosity. b) Cold Shuts.	3-10 20
Welds	a) Cracks, porosity. b) Included flux.	20 1
Plastics	Cracks, crazing.	1-5

- 3.3 **Removal of Excess Penetrant.** Excess penetrant should be removed by spraying with running water at a mains pressure of about 2.11 kg/sq cm (30 lb/sq in) or by the use of an air/water gun. In the case of self-emulsifying penetrants, it may be necessary with some surfaces to use a detergent solution, supplied by the manufacturer, prior to spraying the developer. It is most important to ensure that the rinsing operation is completely effective, otherwise traces of the residual penetrant may remain on the surface and interfere with the subsequent diagnosis of defects.
- 3.3.1 After rinsing, the surfaces of the component should be quickly inspected by means of ultra-violet light to ascertain the efficiency of the rinse. If any general fluorescence is still evident the rinsing operation should be repeated.
- 3.3.2 If a wet developer is to be used, the surfaces need not be dried but drying is essential if a dry developer is to be used. On large parts the excess water can be blown off with clean, dry, oil-free air but when parts are of convenient size, drying in a recirculating hot-air drier is recommended. Excessive time in the drier should be avoided, as the penetrant will slowly evaporate.
- 3.4 **Application of the Developer.** The developer usually consists of a very fine white powder which may be applied in
- the form of a spray, the powder being suspended in a volatile liquid carrier,
 - as a dip with the powder suspended in water or
 - as a dry powder which may be blown on to the component or into which the component may be dipped. The action of the absorbent powder is to draw out the dye from the surface defects, thus indicating their position by the resultant yellowish-green stain when viewed under ultra-violet light.
- 3.4.1 Where it is suspected that microscopic defects may be present, great care is necessary to ensure that the developer is applied evenly and very thinly, since a thick layer might completely conceal a defect holding only a minute quantity of dye.
- 3.4.2 Where a wet developer is concerned, the best results are obtained when the developer is applied by means of a paint-type spray gun operating at an air pressure not in excess of 1.05 kg/sq cm (15 lb/sq in). The pressure pot of the gun should be equipped with a stirrer to keep the developer agitated and the absorbent particles in suspension. Before pouring the developer into the spray-gun it should be well shaken to ensure thorough distribution of the absorbent particles.

- 3.4.3 When requirements are not too exacting, small parts can be dipped into a bath of developer but the action must be performed rapidly to minimise the possibility of the penetrant being washed out of shallow defects. The bath should be agitated from time to time to ensure that the absorbent particles are kept in uniform suspension in the solvent. The formation of pools of developer on the parts during draining must be avoided, otherwise the resultant thick coatings may mask defects.
- 3.4.4 Due to the usually uneven results obtained, the use of a brush for applying the developer is not recommended.
- 3.4.5 After the developer has been applied, the parts should be allowed to stand for at least 15 minutes and should then be examined in a darkened room, using ultra-violet light. Where doubt exists as to the validity of an indication, the part should be left for at least 2 hours and then re-examined. If viewing periods are to exceed 30 minutes, the use of special viewing goggles is recommended to reduce the risk of eyestrain and headaches.

NOTE: Portable lamps specially manufactured for fluorescent viewing are available.

4 Application of the Penetrant Process (with Post Emulsification)

In principle the process is similar to that described in the previous paragraph, except for the addition of the emulsification step. However, the separate application of penetrant and emulsifier does introduce additional factors which must be taken into account and these are described below.

- 4.1 After the parts have been dipped in the penetrant, the drain-off period should not be less than 15 minutes and not more than 2 hours. If the period is less than 15 minutes, dilution of the emulsifier by the penetrant may occur and penetration of contaminated defects may not be complete. If the period exceeds 2 hours, partial drying of the penetrant may occur, resulting in exceptionally long emulsification times. Once an optimum draining period has been determined for a particular part, it should be adhered to within $\pm 20\%$, since this period directly influences the process and effects of emulsification.
- 4.2 The parts should be dipped into the emulsifier (the length of time the emulsifier is allowed on the parts being somewhat critical), and should be held to the minimum time necessary to give a good water wash, since this will result in the highest sensitivity. It should be determined by experience for each type of part and finish and then strictly adhered to.
- 4.3 An average emulsification time is about 2 minutes, but may vary between 30 seconds to 5 minutes, according to the surface condition of the part.
- 4.4 After removal of the emulsifier, the part should be dried, treated in the dry developer and then inspected for defects.

5 Interpretation of Indications

If defects are present and all stages of the process have been applied correctly, they will be indicated by brilliant greenish-yellow marks on the surface of the part; some may appear immediately as the developer dries but others may take longer to develop. The characteristics of the markings, such as the rapidity with which they develop and their final shape and size, provide an indication as to the nature of the defect revealed (see Figure 1).

- 5.1 The rate of staining is an indication of the width and depth of the defect, whilst the extent of staining is an indication of its volume. A wide shallow defect is revealed almost instantly but narrow deep defects may take some time to display the final pattern.

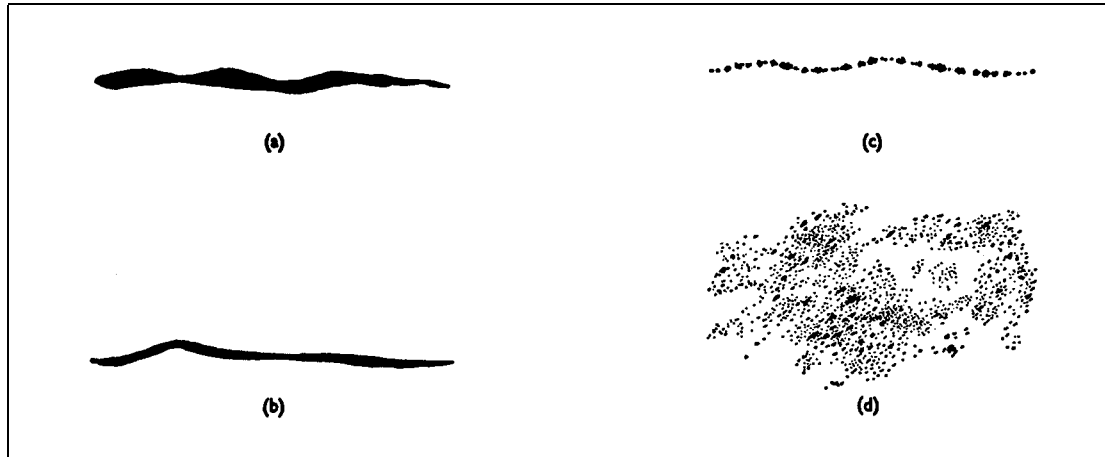

Figure 1 Indications Given by Defects

- 5.2 Scattered dots indicate fine porosity or pitting (Figure 1 (d)), whilst gross porosity may result in an entire area becoming stained.
- 5.3 Closely spaced dots, in a line or curved pattern (Figure 1 (c)), usually indicate tight cracks or laps but such patterns are also characteristic of very wide defects from out of which most of the penetrant has been washed. Wide cracks, lack of fusion in welded parts and other similar defects are indicated by continuous lines as shown in Figures 1 (a) and 1 (b).
- 5.4 All defects should be suitably marked prior to removal of the developer, but crayons should not be used on highly-stressed components subject to heat treatment, since this is known to induce fractures.

6 Removal of Developer

Developer should be removed by washing with water spray or by dipping the component in an aqueous solution of 2% chromic acid. Since the surface is then in a condition susceptible to corrosion (where this is applicable) the prescribed protective treatment should be applied without delay.

Leaflet F-40 Performance Testing of Penetrant Testing Materials

1 Introduction

- 1.1 This Leaflet provides guidance on tests devised to show whether materials used for the penetrant inspection processes described in Leaflet F-20 Penetrant Dye Processes, and Leaflet F-60 Fluorescent Penetrant Processes, are in a satisfactory condition for further use.
- 1.2 The tests described in this Leaflet (there are other equally satisfactory methods) consist of comparing the performance of materials in use with samples of unused materials which are known to be in a condition as received from the manufacturer. The tests should be carried out at regular intervals as specified by the manufacturers and should also be made if it is suspected that the materials may have become contaminated.
- 1.3 In order to provide for the tests, a one-pint sample of all new batches of penetrants and emulsifiers should be taken and stored in airtight glass containers, protected from extremes of temperature and direct sunlight, and suitably identified to show the batch of materials to which they belong.
- 1.4 A metallic specimen containing cracks the location of which are known is necessary to enable the comparison to be made between samples. The preparation of a suitable test piece is described in paragraph 2.

2 The Test Piece

- 2.1 The most suitable type of specimen is the 'demountable' type test piece which can be dismantled between tests for cleaning but a suitable alternative is an aluminium alloy block, as illustrated in Figure 1, containing known fine defects.



Figure 1 Test Piece

- 2.2 The test piece should be cut from 2024 rolled aluminium plate to the dimensions and in the grain direction shown in Figure 1. All excessive markings should be removed from the working face and the test piece cracked by heat-treating in the following manner.

- 2.3 The test piece should be heated over an open flame so controlled that a temperature of 525°C (977°F) is reached in not less than 4 minutes, after which the test piece should be quenched in cold water and then heated gently over a flame to ensure that it is completely dry.
- 2.4 A slot of the dimensions given in Figure 1 should be made in the working face and the two 2 inch square surfaces thus obtained should be identified by lightly etching the surface with suitable symbols, e.g. 'A' and 'B'.
- 2.5 A record of the surface markings of the test piece should be made for subsequent reference in the following manner. The penetrant process should be applied to the test piece by hand under ideal conditions and using materials of a known standard and of the same type as those for which the test piece will be used. After allowing the defect indications to develop for a period of 15 minutes, the test piece should be photographed. Finally the test piece should be cleaned by the method described in paragraph 4.

3 Use of Test Piece

- 3.1 A test piece prepared for use with dye penetrants must not be used for testing fluorescent penetrants and vice versa. In this way the risk of contamination, which would give a false indication of the quality of the material being tested, is considerably reduced.
- 3.2 The test piece should be used by dipping surface 'A' into a sample of unused material and surface 'B' into a sample of the material under test. The test piece should then be allowed to drain for not less than 20 minutes, care being taken to ensure that the penetrants cannot mix.
- 3.3 After draining, both halves of the test piece should be washed simultaneously by the normal process method (see Leaflets F-20 or F-60, as applicable), notice being taken of the ease with which each half is cleaned. The test piece should then be dried and developed by the normal process method and allowed to stand for 15 minutes.
NOTE: Where the recommendations given above would not be suitable for a particular process, the general principle should be followed but adapted as necessary.
- 3.4 The two halves of the test piece should be compared one with the other and with the record of the initial test for the following:
 - a) Vividness of indications;
 - b) Definition of indications;
 - c) Extent to which very fine defects are revealed;
 - d) Ability to retain indications in wider cracks;
 - e) Background contamination.
- 3.5 After making the comparisons described above it should be possible to arrive at one of the following conclusions.
 - a) Both halves of the test piece compare favourably with each other and with the record of the initial test, it can be concluded that the material under test and the process used are satisfactory.
 - b) If the half of the test piece treated with unused material is comparable with the record of the initial test but the half treated with used material is not, this suggests that the used penetrant has become contaminated or has otherwise deteriorated and should be discarded.

- c) If both halves of the test piece compare favourably one with the other but not with the record of the initial test, this suggests that the whole or some part of the process is at fault and should be investigated. However, the possibility of the test piece having become contaminated should not be overlooked. Possible faults with the process include incorrect temperatures, excessive washing and incorrect development techniques.

4 Restoration of Test Piece

- 4.1 On completion of each test the test piece should be thoroughly cleaned to remove all traces of contamination.
- 4.2 After cleaning the test piece should be stored in an airtight container in a mixture of 50% trichloroethylene and 50% toluene until required for further use.
- 4.3 It should be borne in mind that the useful life of the test piece depends entirely on the effectiveness of the restoration process.

INTENTIONALLY LEFT BLANK

Leaflet F-50 Ultrasonic Flaw Detection and Thickness Measurement

1 Introduction

- 1.1 The methods of crack detection dealt with in Leaflets F-10, F-20 and F-30, are of considerable value for finding surface defects but are unable to reveal the presence of internal flaws which are distant from the surface. This Leaflet gives general guidance on the application and scope of ultrasonic sound waves for detecting surface and internal flaws in materials and parts and for the measurement of thickness.
- 1.2 Ultrasonic testing is not a complete substitute for other methods of flaw detection and should generally be regarded as complementary to them. It should be considered an extension to efficient inspection but should not be regarded as a foolproof method without considered trials and its indiscriminate use could be uneconomical and misleading. There are instances however, particularly in aircraft applications, where ultrasonic testing is the only satisfactory method, e.g. when a distant defect lies parallel with the only available surface of a component. The degree of skill and experience required to use ultrasonic apparatus and to interpret the indications obtained, varies with the complexity of the parts to be examined, the type of equipment available and the acceptance standards specified. Operators should be properly trained and qualified on the equipment in use.
- 1.3 Cavities, inclusions and cracks in cast metal prior to fabrication by extrusion, rolling, forging, etc., can be found by ultrasonic techniques and automatic scanning devices are often used during the manufacturing process. Large steel or aluminium forgings, components welded by gas, arc or flash butt methods and a variety of parts such as turbine discs, propeller blades and wing spar booms may all be examined at various stages during manufacture. Ultrasonic methods can also be used for finding fatigue cracks and other defects arising from operating conditions, during the periodic inspection of airframe and engine parts.
- 1.4 Thickness measurement by ultrasonic methods has some aircraft applications. It provides a satisfactory means of measuring the skin thickness of hollow propeller or turbine blades and for checking tubular members or sheet metal assemblies. Delamination of bonded assemblies can also be checked by similar methods.

2 Sound Waves

- 2.1 Ultrasound describes sound at a pitch too high to be detected by the human ear. The frequencies used in ultrasonic testing are normally within the range 500 kHz to 10 MHz.
- 2.2 **Sound Energy.** Sound is energy produced by a vibrating body, the energy being transferred through a medium by the wave-like motion of the particles making up that medium. The frequency of the waves is the same as that of the vibrating body and the wavelength is dependent upon the speed of sound in the particular material. This is illustrated in Figure 1, the 'y' axis representing the distance of a vibrating particle from its mean position and the 'x' axis its distance from the sound source. The time taken for the sound to travel one wavelength (λ) is the same as the time taken for the vibrating body to execute one complete cycle.

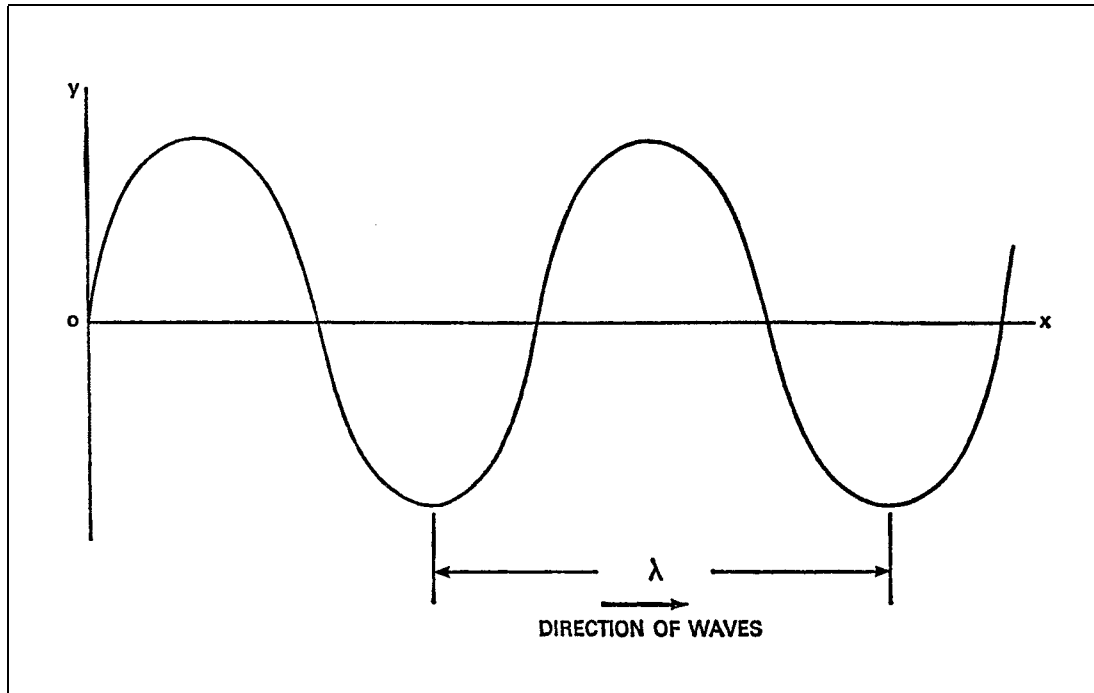

Figure 1 Form of Sound Waves

- 2.3 **Wave Types.** Three main types of waves may be generated. The vibrations in **Longitudinal** (compression) waves are in the same direction as the sound motion and the vibrations in **Transverse** (shear) waves are perpendicular to the sound motion. Waves generated along the surface of a material, known as Surface waves, have an elliptical motion. Any of these types of waves may be generated in solids but only longitudinal waves can normally be generated in liquids or gasses. Other types of waves exist and are sometimes used in ultrasonic testing (e.g. Lamb Waves, which are vibrational waves capable of propagation in thin sheet material).
- 2.4 **Speed of Sound.** The speed of sound through any particular material depends on the density and elastic constants of that material. Transverse waves travel at approximately half the speed of **Longitudinal** waves and surface waves at approximately 90% of the speed of **Transverse** waves.
- 2.5 **Beam Characteristics.** When sound waves are generated by a flat disc vibrating at ultrasonic frequencies the beam of sound is initially parallel and then, at a distance from the disc related to its diameter and the sound frequency, spreads out and loses intensity, the spread increasing as frequency and disc diameter are reduced. Within the near (parallel) zone variations in sound intensity occur and absorption results in a loss of energy with increased distance from the source. A material with a large grain structure or holes associated with porosity absorbs more energy than one with a fine grain structure but, since absorption is also a function of frequency, by decreasing the frequency absorption is also reduced.
- 2.6 **Mode Conversion.** When a beam of sound is directed at the boundary between two solid materials at an angle other than normal to the interface, both reflection and refraction occur as shown in Figure 2. If material 'A' is a liquid, as in ultrasonic testing, only longitudinal waves will be reflected. Adjustment of angle 'a' will enable any of the main types of waves to be injected into material 'B'. Unfortunately mode conversion also produces unwanted reflections from the surface of a component which, due to the different speeds of the various types of waves, may give confusing results.

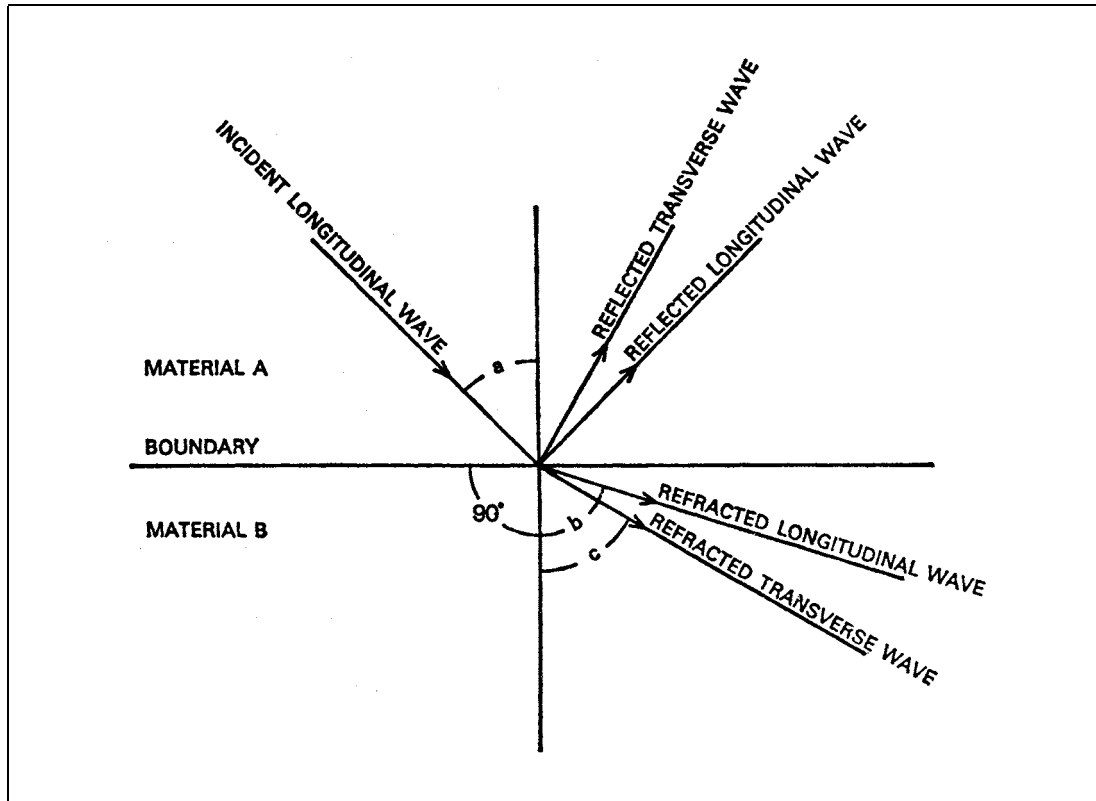

Figure 2 Mode Conversion

3 Generation and Detection of Sound Waves

3.1 The sound waves used in ultrasonic testing are produced and detected by means of an electro-mechanical transducer, i.e. a device which converts electrical energy into mechanical energy and vice versa. The properties of the materials used in the manufacture of transducers are discussed in the following paragraphs.

3.2 Piezoelectric Effect

3.2.1 If a mechanical stress is applied in a specified direction to certain natural crystals such as quartz, an electrical field is produced in which the voltage is proportional to the magnitude of the stress. Similarly, if a voltage is applied between the crystal faces a proportional mechanical stress is produced in the crystal. By applying an electrical potential to the faces of an X-cut quartz crystal (i.e. a crystal cut in the form of a disc whose faces are normal to one of the 'X' axes) a vibration is produced, the frequency of which depends on the thickness of the crystal. Conversely, when such a crystal is caused to vibrate under the influence of a sound beam an alternating current is produced between the crystal faces.

3.2.2 A similar effect is produced in all electrically insulating materials and certain ceramic materials such as barium titanate are particularly sensitive in this respect. Transducers made from these materials consist of a large number of tiny crystals fused together and are permanently polarised during manufacture so as to vibrate in one plane only.

3.2.3 Piezoelectric crystals lose their activity when heated above a particular temperature and this may be a severe limitation for certain uses.

3.3 **Crystal Frequencies.** To achieve maximum efficiency crystals must be operated at their natural frequency (determined by their dimensions and elastic properties).

Transducers used in ultrasonic testing are generally used in this way when searching for cracks but for resonance testing different methods are used (see paragraph 4.4).

- 3.4 **Acoustic Coupling.** The amount of energy transferred across a boundary between two materials depends on the Characteristic Impedance of each material, which may be taken as the product of the density and the speed of sound in each material. Good coupling will be provided when the Characteristic Impedance of the two media are closely matched and the capability of ultrasonic flaw detection depends on these factors. The coupling between metal and air is extremely poor and it follows that if any air is present between a probe and the material being tested very little energy will be transferred across the interface. For this reason a liquid couplant such as water, oil or grease is normally used in ultrasonic testing.
- 3.5 **Reflection.** If an ultrasonic beam is injected into a material it will continue through that material until it strikes a surface and will then either pass through the interface or be reflected, depending on the factors outlined above. If the beam strikes a discontinuity, crack or void in the material the reflection may be picked up by a suitably placed transducer, the amount of reflected energy depending on the nature of the defect and its orientation. Most of the energy striking an external surface or void will be reflected but in cases such as bolt holes or bushes which have been well lubricated very little reflection may occur.
- 3.6 **Probes.** A probe consists of a transducer mounted in a damping material and connected electrically to the test set. For any particular application it may be necessary to use a probe of a particular design so that a sound beam is injected into the material at an angle normal to the expected defect. The required angle of the incident beam is achieved by mounting the transducer on a suitably shaped plastic block. Similar blocks are also used for injecting sound waves into a material with a uniformly shaped surface such as a tube. In certain applications a wheel probe, consisting of a transducer mounted inside an oil-filled plastic tyre, has been found suitable for high speed automatic scanning.
- 3.7 **Display**
- 3.7.1 The most usual method of displaying the information obtained in ultrasonic testing is by means of a cathode ray oscilloscope. A pulsed transmission technique is normally used and is described below; other methods are described in subsequent paragraphs.
- 3.7.2 In the cathode ray oscilloscope (Figure 3), a triggering device causes both the pulse generator and time base control to operate simultaneously. The time base control (connected to the 'X' plates of the oscilloscope) deflects the trace produced by a beam of electrons, so that the trace moves across the screen from left to right in synchronisation with the ultrasonic pulse transmissions. Vibration of the transducer results in an electrical signal at the 'Y' plates of the oscilloscope, which deflects the electron beam in the form of a peak (A) in the time base. Any returning echo acts on the receiving transducer to produce a second peak (B), the distance of the flaw from the surface being represented by half the distance between A and B. This distance can be calculated from knowledge of the speed of sound in the particular material and the time base scale. The time base scale is usually variable and provision is often made for the attachment of a graticule scale to the oscilloscope screen so that direct measurements may be taken.

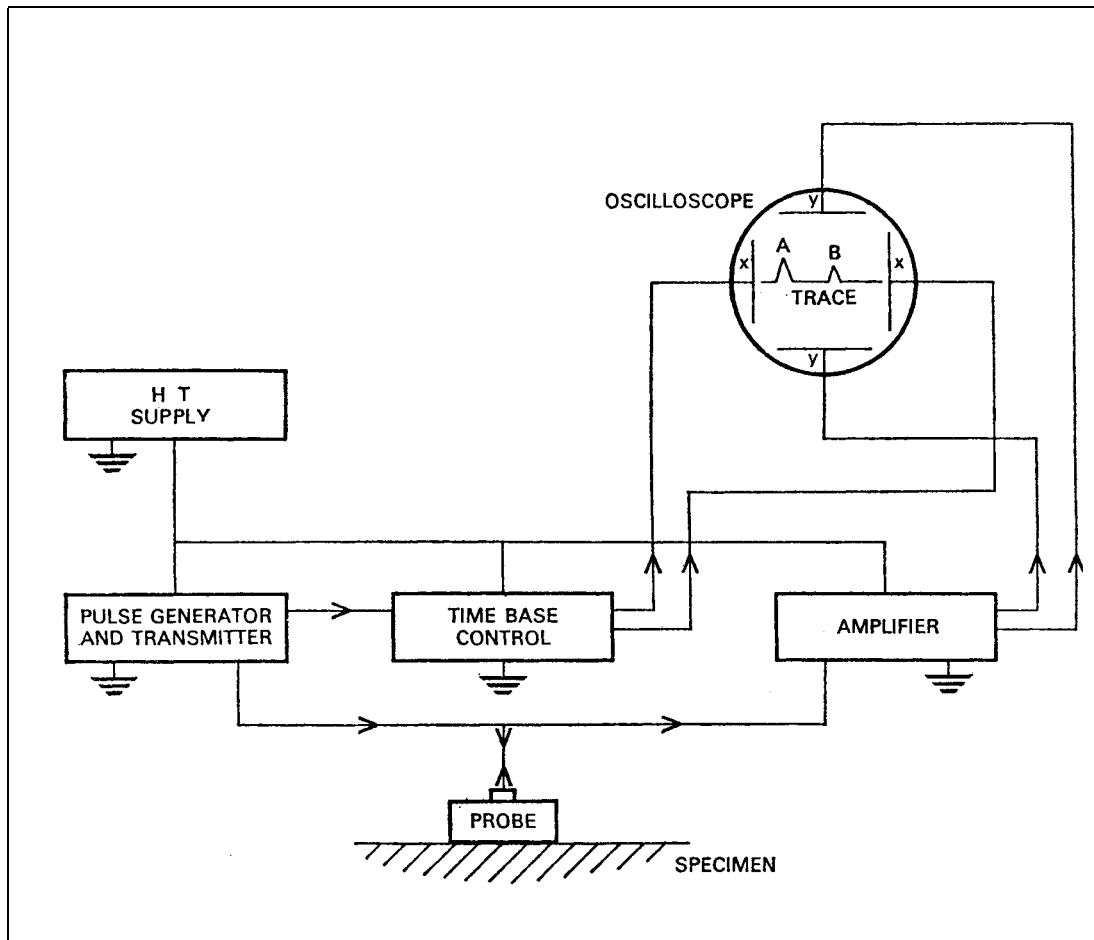

Figure 3 Simple Block Diagram of Ultrasonic Set

- 3.7.3 Transducer crystals are usually damped to reduce the length of the pulse, but a layer (known as the 'dead zone') is left immediately below the surface of the test material in which defects parallel to the surface can only be examined from an opposite face. Increasing the ultrasonic frequency would reduce the depth of this layer but would also result in high absorption and might not be suitable for certain materials.
- 3.7.4 The pulse repetition frequency is extremely rapid to ensure a good trace on the oscilloscope, but must not be so quick that sound energy is still reflecting within the specimen when the next pulse is initiated.
- 3.7.5 The presentation described above is known as 'A scan' but the information may also be displayed in the form of a side elevation (B scan) or a plan view (C scan), the latter usually being used in automatically produced paper read-out form from a normal A scan oscilloscope.

4 Methods of Operation

- 4.1 **Transmission Method.** If a transmitting and a receiving probe are placed on opposite sides of a specimen (Figure 4), sound waves will be transmitted directly through the material and picked up by the receiving probe. If a flaw in the material interrupts the sound beam, a loss of signal will result and the second peak on the time base will disappear. Longitudinal wave probes are normally used for transmission

scanning but angled probes may also be used when only one surface is accessible (Figure 5).

4.2 **Pulse-echo Method**

4.2.1 This method relies on reflections from a defect being detected by the receiving probe and either a single transceiver probe or separate transmitting and receiving probes may be used (Figure 6).

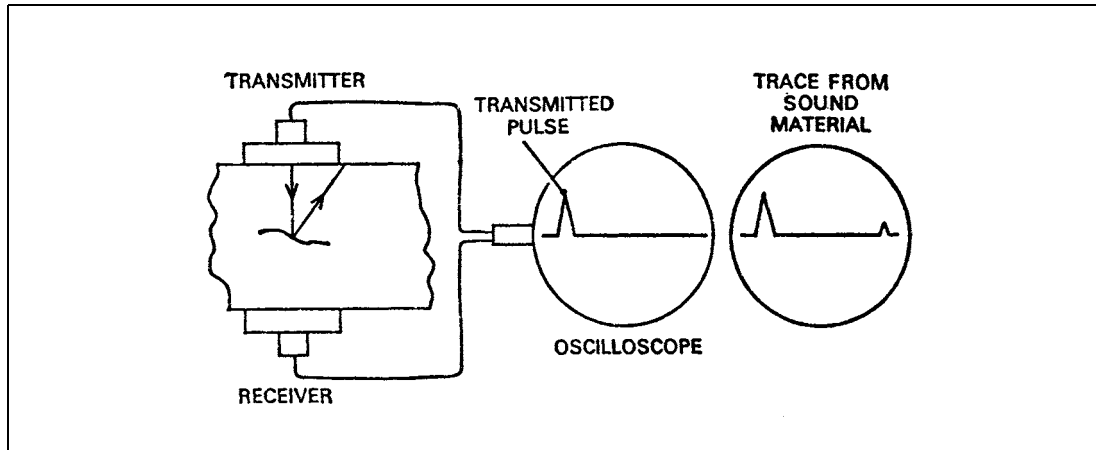

Figure 4 Normal Transmission Technique

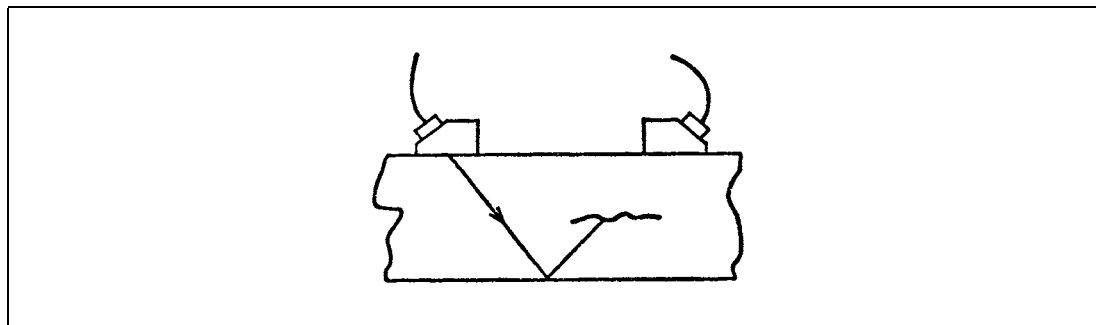

Figure 5 Alternative Transmission Technique

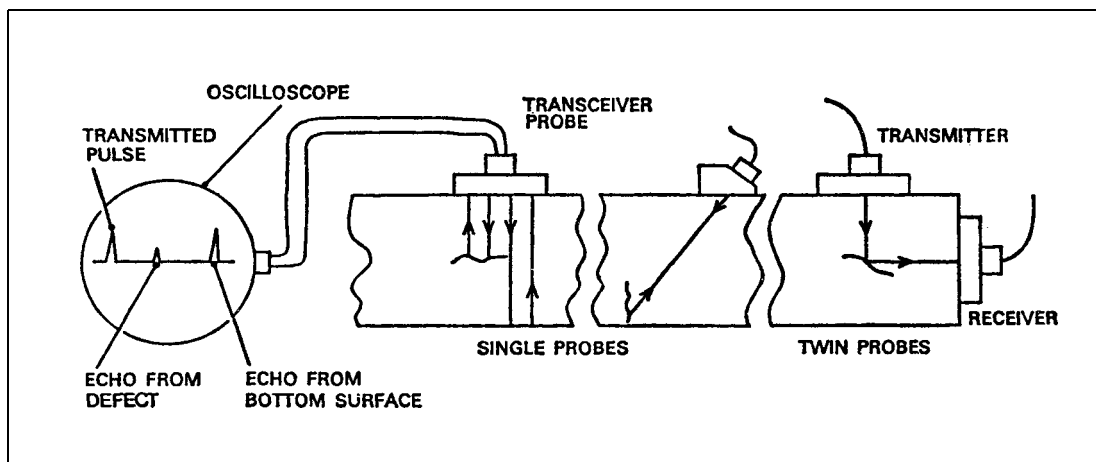

Figure 6 Pulse-echo Techniques

- 4.2.2 Pulse-echo methods are also used for finding cracks at right angles to a surface. An angled probe is used to inject surface waves into a material, the waves following the surface contour and reflecting back to the probe from any discontinuity (Figure 7).

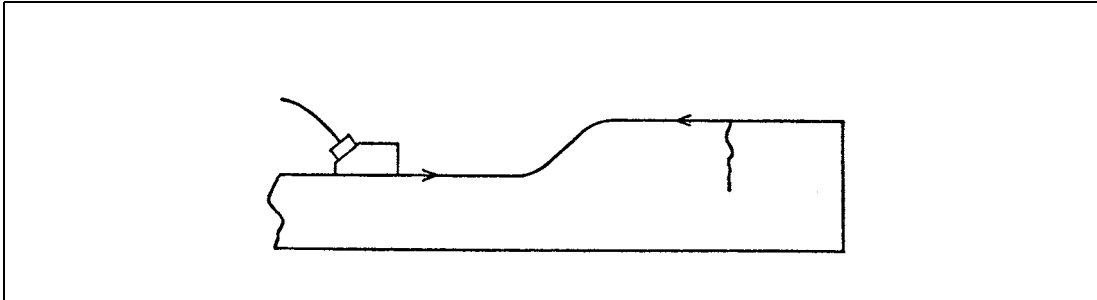

Figure 7 Surface Wave Testing

- 4.3 **Immersion Testing.** The technique of holding a probe in contact with the specimen is known as 'contact scanning', but there is also an important method of inspection known as 'immersion scanning', in which the specimen is immersed in a tank of water and a waterproof probe placed in the water, above the specimen (Figure 8). Pulse-echo techniques are normally used but transmission techniques would also be possible.

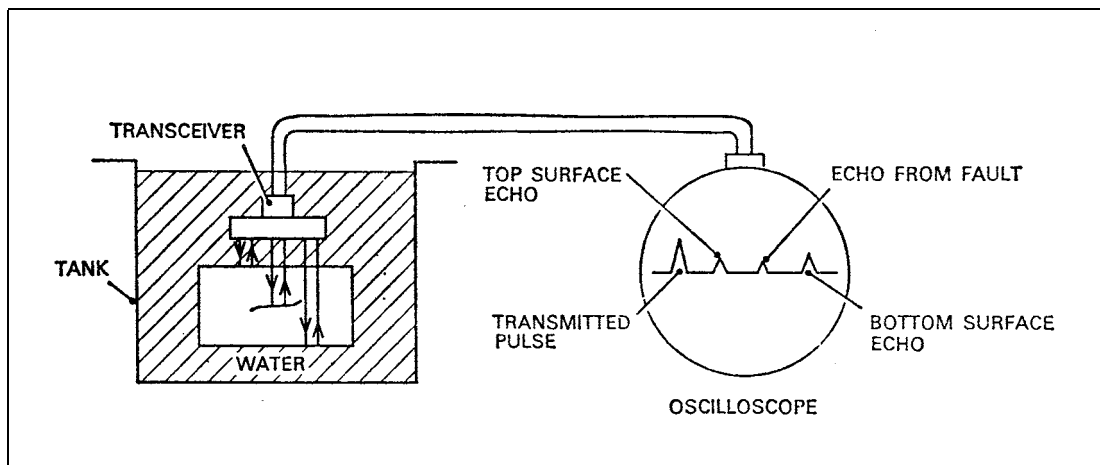

Figure 8 Immersion Testing

- 4.3.1 Pulses of ultrasound are emitted by the probe and pass through the water into the specimen. The top and bottom surfaces of the specimen are shown on the oscilloscope, together with indication from the transmitted pulse and any flaws within the material.
- 4.3.2 The distance between the probe and specimen must be selected so that confusing repeat echoes are avoided and can also be set to avoid use of the near zone in examining the specimen.
- 4.3.3 The trace produced by a fault-free specimen will normally produce three peaks, the space between the second and third, i.e. the depth of the specimen, being the only part of interest during inspection. The time base is usually delayed and its scale expanded, so that indications of defects are more easily seen.
- 4.3.4 Immersion scanning lends itself to automation and is frequently used for the inspection of parts of simple shape. Parts of complicated geometric shape present difficulties in that expensive electronic circuits would be required to differentiate between surface reflections and internal flaws.

- 4.4 **Resonance Technique.** If a sheet or plate specimen is caused to vibrate in the direction of its thickness, resonance will occur if the thickness is equal to exactly half the wavelength of the inducing vibrations. By using a quartz transducer to vary the frequency of the vibrations, resonance is produced in the specimen and this frequency is displayed to indicate the thickness. A laminar type of defect, or loss of bonding, can also be detected by resonance methods providing that the separation is dry.
- 4.5 **General Considerations**
- 4.5.1 A number of factors must be considered before making an ultrasonic inspection and special techniques may have to be developed for a particular situation.
- 4.5.2 **Surface Conditions.** There are various surface conditions, such as rust, scale, loose paint etc., which will prevent inspection by ultrasonic methods and these must be removed. The rough surfaces such as are found on cast billets may present difficulties, but the use of grease as a couplant may be effective, or, alternatively, the immersion technique may be used. The shape of the specimen should also be considered so that slipper blocks may be made to provide the best acoustic contact.
- 4.5.3 **Sensitivity.** With too great a sensitivity, porosity and large grain size will hide flaws in a material by producing numerous peaks on an oscilloscope. It is important, therefore, that the sensitivity of the test equipment be adjusted so that unimportant features can be disregarded. The amplitude of reflections depends mainly on the size of the flaw and if the maximum acceptable size of defect were specified, then any reflection producing peaks higher than this would be known to be unacceptable.
- a) For longitudinal wave scans the acceptable size of defect is related to a flat bottomed hole of a particular diameter. Test blocks are used in which holes of various sizes are drilled and oscilloscope sensitivity is adjusted to give a peak of, say, 2.54 centimetres (1 inch) in height on the reflection from the hole of specified size. Blocks with holes drilled to different distances from the surface may be required to check the effect of attenuation on peak height. During test, defects producing peaks lower than 2.54 centimetres (1 inch) can then be ignored.
 - b) For transverse wave scanning the acceptable size of defect is related to a hole or saw cut made in a block of the same material and thickness as that to be inspected.
 - c) Notwithstanding the sensitivity setting of the oscilloscope, some defects, such as cracks, may extend over a considerable distance and therefore be unacceptable. These would be recognised by a constant peak as the probe was moved in the direction of the crack.
 - d) A special test piece has been designed by the International Institute of Welding and may be used for checking ultrasonic equipment in respect of both longitudinal and transverse waves; oscilloscope scale and resolution can also be verified.
- NOTE:** Most ultrasonic test sets are now fitted with an attenuator. This is a device which applies calibrated attenuation to the received signal, enabling received signal strength to be measured, in decibels, relative to the signal from a reference standard.
- 4.5.4 **Choice of Frequency.** Both absorption and diffraction of sound waves are a function of the frequency used. For any particular test it is necessary to take into account the size and position of possible defects, the nature of the material and the distances to be scanned. With a coarse grained material a low frequency must be used, especially in large specimens, but with a fine grained material a higher frequency may be used, with a consequent increase in sensitivity.

- 4.5.5 **Type of Defect.** When preparing a technique for the inspection of a particular item, knowledge of the type of defect which can be expected is of great assistance. For example, if a casting has a known tendency to crack at a particular position during service, sketches can be provided showing the oscilloscope patterns obtained from both sound and faulty castings; inspectors will then not be misled by spurious reflections due to the shape of the castings.

5 Practical Applications

5.1 Testing Ingots, Billets and Heavy Forgings

- 5.1.1 Large blocks of metal of simple shape are particularly suited to testing by ultrasonic methods, provided that a suitable technique and frequency are used.
- 5.1.2 Rectangular blocks can be checked by systematically scanning three faces with a longitudinal wave probe. Because it is difficult to detect flaws which are close to the surface it may be advisable to scan all faces, but this will not be necessary if surface material is to be subsequently machined off.
- 5.1.3 Certain cast ingots may have such a coarse grain structure that the ultrasonic beam is scattered to a degree which renders flaw detection difficult or even impossible. If echo techniques prove to be unsuitable, the transmission method should be tried, but if this also is impracticable, it may be necessary to delay the inspection until rolling or forging have been carried out.
- 5.1.4 Inability to obtain satisfactory results can often be traced to poor acoustic coupling, a difficulty which can be overcome by use of the immersion technique.
- 5.1.5 It is common practice in industry to use automated ultrasonic techniques on billets, pipes and other similar products. A water jet, passing through a jacket within which the transducer is mounted, acts as the coupling agent and electronic alarms trigger marking systems which record the position of a defect. An automated immersion technique is also sometimes used on finished size thin wall tubes, using Lamb waves for flaw detection.

5.2 Testing Welded Joints

- 5.2.1 Most types of welds in thick materials can be inspected by ultrasonic methods, but thin sheet metal welds are more satisfactorily checked by the use of X-rays (Leaflet F-60). It is good practice to obtain a separate specimen in the same material and to drill holes (as shown in Figure 9) which will indicate if it is possible to detect flaws at these positions. Experience has shown that this is not possible with all types of material and welding techniques.
- 5.2.2 Butt welds made by gas or arc welding methods can be checked by using an angled probe which injects transverse waves towards the weld line. If flaws are present in the weld, the beam will be reflected back to the probe. Experience in the application of scanning methods has made it possible to identify most types of welding defects, although it is not always easy to determine the acceptability of the weld from this information. When doubt exists, the information derived from the ultrasonic test should be correlated with other methods of testing, such as radiography.

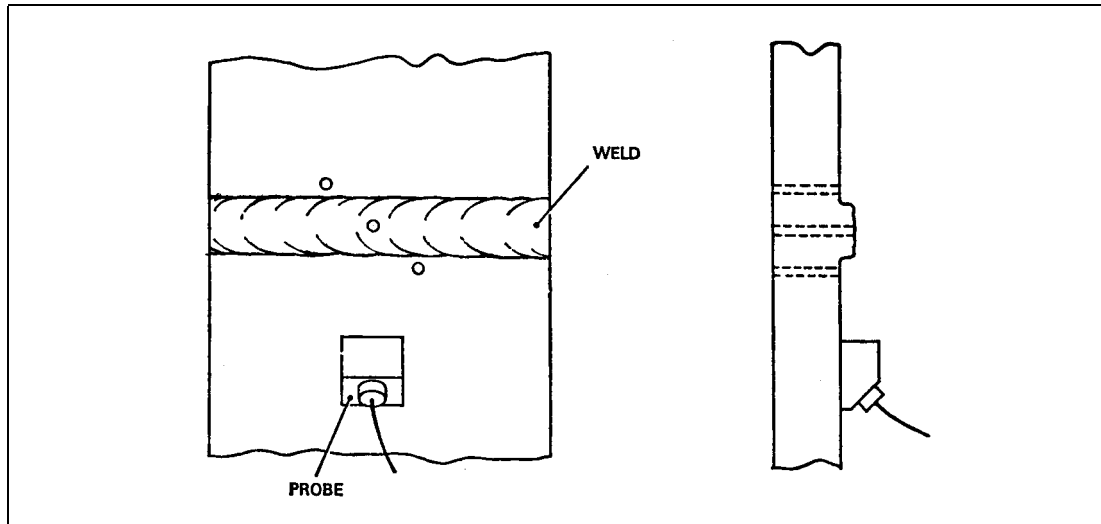

Figure 9 Test Holes in Weld Sample

- 5.2.3 Special techniques are required for testing flash butt welds, since they contain no filler metal and flaws are normally in the plane of the weld. One method of testing is to position two probes as shown in Figure 10. Scanning is carried out by moving both probes simultaneously in opposite directions so that any flaws are detected by the receiver probe. The probes may, in some instances, be positioned on the same side and certain specimens are best scanned by fixing the probes in a jig to ensure correct alignment. To determine the best method for inspecting a particular weld, all these methods should be tried until the most consistent results are obtained.

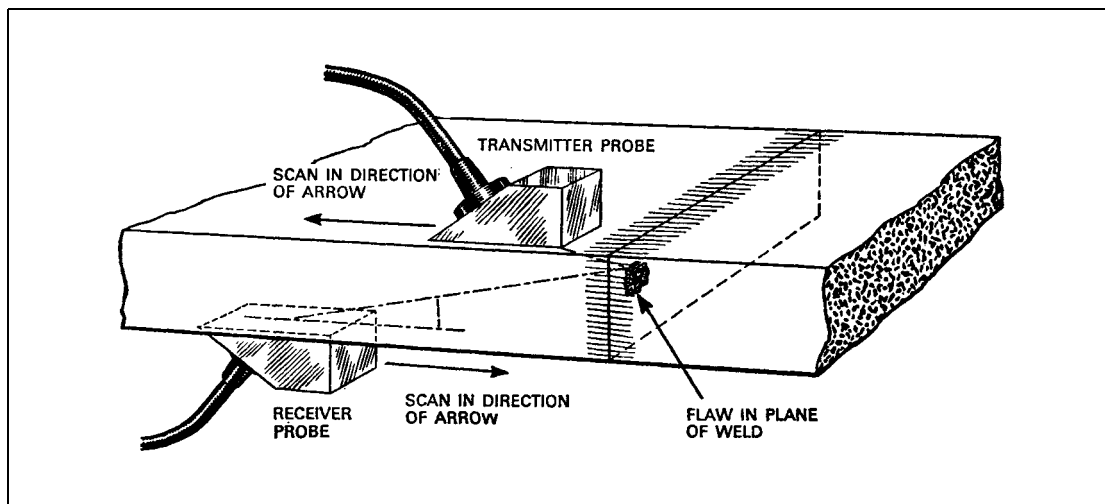

Figure 10 Scanning Method for Finding Flaws in Flash Butt Welds

5.3 Thickness Measurement

- 5.3.1 **Pulse-echo Method.** By the choice of suitable probes and the selection of appropriate test frequencies, several types of flaw detectors can be used for measuring thickness, but the accuracy of most is limited when dealing with material of the thin gauges used in aircraft manufacture. Their main application is therefore, the measurement of thick material during machining and manufacturing operations, particularly when the parts concerned would have to be removed from jigs or machines in order to measure them by physical methods. Vertical probes are normally

used and may be either the transceiver type or a probe combining separate transmitting and receiving crystals.

- 5.3.2 **Resonance Method.** This method is suitable for the measurement of new aircraft skin, structure and tubing and is normally only used during aircraft manufacture. A quartz crystal is excited by means of a valve oscillator, at a frequency well below the fundamental resonant frequency of the crystal and held in contact with the specimen. This causes the specimen to vibrate in its thickness direction and the frequency of the sound wave is increased until the specimen resonates. An increase in the amplitude of the vibrations results, with a corresponding increase in crystal voltage. If the crystal frequency is further increased, resonance recurs (i.e. at the next harmonic) and the fundamental frequency of the material and hence its thickness, can be determined. Resonances may be shown on a suitably calibrated oscilloscope screen but more simple methods such as a voltmeter reading or an audible note in earphones are often used.

NOTE: The thickness is equal to an exact number of half-wavelengths, which can be calculated from the speed of sound in the material and the fundamental resonance frequency.

5.4 **Detection of Lamination**

- 5.4.1 There are several ways of checking materials for internal laminations and similar methods may also be used to determine the integrity of bonded structures. The pulse-echo technique may be used on plate over 1.27 cm ($\frac{1}{2}$ inch) thick but it is unsuitable for thinner sections.

- 5.4.2 **Transmission Method.** If a transmitting and a receiving probe are held in alignment on opposite sides of a specimen, any lamination inside the specimen will interfere with the transmission of the ultrasonic waves and will be shown by a reduction in received signal strength. However, because of the need to have access to both sides of the specimen, this method has limited application in aircraft work.

- 5.4.3 **Resonance Method.** It has been explained that resonance occurs at one of the natural frequencies of the material, the thickness being related to an exact number of half-wavelengths of the ultrasonic beam. If a material is laminated, or the bond between two layers is defective, resonance will occur at a different frequency and will result in a change in the shape of the oscilloscope trace. Special test sets have been developed for the inspection of bonded structures and techniques have been established from which it can be determined whether a bond is satisfactory or not when the bond is dry.

- 5.4.4 **Multiple Echo Method.** The time base and sensitivity of an ultrasonic set can be adjusted to give a number of boundary reflections. With a set adjusted in this way, any laminations present in a specimen being scanned will show up as a sudden increase in the number of reflections, e.g. if the specimen is laminated at its centre, the number of peaks on the oscilloscope screen will be doubled.

- 5.4.5 **'Lamb' Wave Method.** Laminations near to the surface of a metal plate are very difficult to detect. However, Lamb waves may be generated in plate which approximates, in thickness, to one wavelength of the sound beam and any lamination will result in a change in the screen display. The angle of the probe is very important and varies with the thickness of the lamination; it is necessary, therefore, to scan with a variable angle probe.

6 Techniques for Aircraft Parts

- 6.1 Ultrasonic testing is widely used on parts removed from aircraft, but is also applicable to the examination of parts in situ where other types of inspection would require extensive disassembly. Techniques are established to ensure consistent results and these are written into the appropriate manuals.
- 6.2 Aircraft structural parts which can be checked by ultrasonic methods include large forgings, wheels, engine bearers, axles etc. Before these parts are installed in aircraft, or at times when they are removed during overhaul, the immersion method of testing will often give good results. Large tanks and automatic testing equipment are not necessary for examining parts of manageable proportions; such parts can be submerged in water in a convenient container, the probe being mounted in a fixture to ensure that the required beam angle is maintained. However, certain parts, such as wheels, lend themselves to automated methods and some aircraft operators have found these to be worthwhile; their use also permits an electronic record of each inspection to be kept. The essential requirement for any test is a standard of reference and this may be provided by using an identical part of known condition as a specimen. As a check on sensitivity, defects can be introduced in the reference specimen, by drilling small holes or by spark erosion, at positions where defects are likely to occur. Reflections introduced by these artificial defects can be compared with the traces obtained from a part under test.
- 6.3 The chief value of ultrasonic examination in situ, is that defects and in some individual cases corrosion, can be found in areas not accessible for visual examination. Provided that one smooth surface is accessible to the ultrasonic probe, most forgings, castings and extrusions can be satisfactorily inspected. On some aircraft, spar boom and some similar structural members require periodic examination for fatigue cracks, but the areas of suspected weakness may not be accessible for examination by visual or dye-penetrant methods. Ultrasonic testing gives quick results on those defects which lend themselves to this form of testing, i.e., the defect is normal to the directed beam. In this instance radiographic techniques would be quite unsuitable.
- 6.4 When carrying out ultrasonic tests in situ, the surface to be scanned by the probe should be thoroughly cleaned and covered with oil or grease to provide good acoustic contact. If parts are removed for testing, then water may be used as a couplant, but the parts should be thoroughly dried before being put into storage or service.

Leaflet F-60 Radiological Examination of Aircraft Structures

1 Introduction

- 1.1 This Leaflet gives guidance on the operation of radiological testing apparatus and the establishment of satisfactory inspection techniques.
- 1.2 The use of radiography in accordance with an approved technique will often facilitate the inspection of structures during manufacture, overhaul and maintenance and can be used for the examination of structures which would otherwise be inaccessible. A number of airframe and engine manufacturers and aircraft operators, have devised techniques for particular inspections. These are written into the appropriate Maintenance Manuals and Maintenance Schedules or included in a separate Non-destructive Testing (NDT) Manual. General information on radiographic techniques is included in British Standard BS M34.
- 1.3 Radiographic methods may also be used to advantage where normal physical methods of measurement are difficult or impractical. It has been shown, for example, that it is extremely difficult to detect eccentricity in items with long bored or counterbored holes and that wall thickness in these cases can be accurately determined by means of a radiograph. Where this type of measurement is considered necessary the appropriate technique should be quoted on drawings or inspection instructions.
- 1.4 Radiography should be considered as an extension to efficient inspection and is sometimes of value in providing a second opinion where inconclusive results have been obtained by other methods. It should not be regarded as a foolproof method of inspection without considered trials and its indiscriminate use would be both uneconomical and misleading.
- 1.5 The misuse of radiographic equipment could result in the release of physically harmful radiations and it is therefore extremely important that operators should be properly trained and aware of the regulations concerned with safety. The provision of adequate protection is not dealt with in this Leaflet; it is emphasised however, that the operating procedures and conditions set out in 'The Radioactive Substances Act (1993)' and the 'Ionising Radiations Regulations No.3232 (1999)' must be observed at all times when radiography is used for aircraft inspection.
- 1.6 The importance of proper training is also evident in the interpretation of radiographs. Incorrect conclusions could result in the clearance of unsafe structures or components or, conversely, the scrapping of expensive items which are really sound.

2 Sources of Radiation

- 2.1 There are two forms of electro-magnetic radiations which can be used in radiography, namely X-ray and gamma rays. The main difference between the two is in the method of propagation. The radiations are of very short wavelength (0.001 Å to 2Å) and are capable of penetrating solids, the rays passing through a specimen being used to expose a sensitised film. X-rays also cause the fluorescence of certain chemicals and this reaction is sometimes used to produce an image on a phosphor screen; this technique is known as fluoroscopy.

2.2 X-Rays

- 2.2.1 This particular form of electro-magnetic radiation is produced when electrons, travelling at high speed, collide with matter in any form.
- 2.2.2 The basic requirements for the production of X-rays are a source of electrons, a means of accelerating the electrons to high speed and a target to emit the X-rays. A typical circuit of an X-ray set is shown in Figure 1. The X-ray tube is an evacuated chamber in which the electrons are derived from a filament, set in a focussing cup and heated to incandescence by a low voltage current; electrons are released and form a 'space charge' around the filament. When a high potential is applied, electrons accelerate from the filament (the cathode) to the anode and strike the target, which then emits X-rays.
- 2.2.3 Only approximately 1% of the electron energy is converted into X-rays the rest being changed into heat and light. For this reason the anode consists of a substantial block of copper, in which the target is set and is often cooled by the circulation of liquid. The target is made from tungsten to resist the high temperatures produced by the electrons at the focal spot.
- 2.2.4 X-rays are emitted in all directions from the target but the tube is normally shielded so that a beam is emitted in the shape of a 40° cone. However, some X-ray tubes are designed to emit different shaped beams for particular uses.

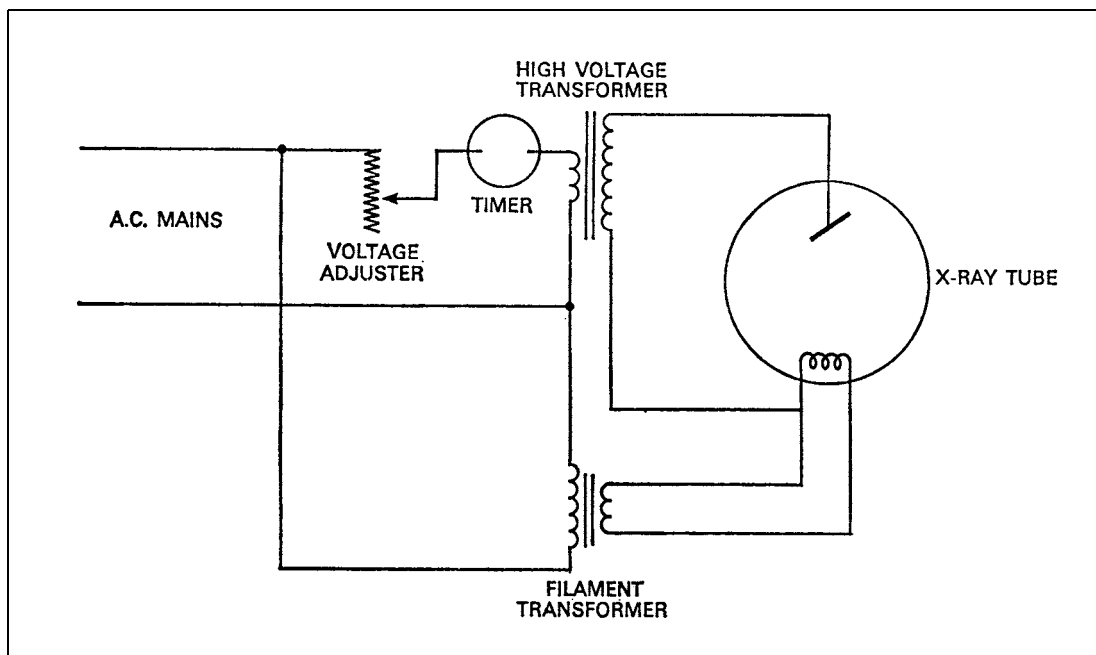

Figure 1 Typical Circuit of an X-ray Set

- 2.2.5 The electrical supply to an X-ray tube is normally from the a.c. mains through a transformer and, since electrons can only flow from the cathode to the anode, a pulsed tube current results. Some X-ray sets use complex electrical circuits to produce a constant potential in the tube, but they are generally very expensive and unsuitable for the type of portable equipment which is generally used on aircraft. The wavelength of the X-rays is inversely proportional to the voltage applied and the X-rays produced will vary in wavelength down to a minimum value determined by the peak voltage. This is known as a 'continuous spectrum' and is a characteristic of all X-ray tubes. The penetrating power of X-rays increases as the wavelength decreases and high voltages are therefore used when radiographs of dense materials, such as steel, are required.

- 2.2.6 **Penetrating Power.** Although penetrating power is related to the voltage of the X-ray tube, it is often indicated by the 'half value layer' (HVL) of the beam. This represents the thickness of a given material (usually aluminium or copper) which will reduce the intensity of the beam to half its original value. This method is not completely accurate however, since the longer wavelengths, being less penetrating, are removed first and quality of the beam is changed. If additional filtration (i.e. thicker aluminium or copper sheets) is provided it will be seen that the HVL increases progressively until a constant beam quality is obtained.
- 2.2.7 **Types of Equipment.** X-ray equipment is normally graded according to the voltage range over which it is designed to operate. The portable sets used in aircraft work normally cover voltages between 10 kV and 250 kV, but no single set will cover this whole range. Tubes designed for high voltages possess inherent filtration properties, which, combined with space charge effects, will preclude the emission of an effective X-ray beam at low voltages. Typical ranges covered by portable sets are 10 kV to 100 kV and 100 kV to 250 kV.
- 2.3 **Gamma Rays**
- 2.3.1 Electro-magnetic radiations resulting from the disintegration of radioactive materials are known as gamma rays. The isotopes now used in radiography are artificially produced and emit rays of similar wavelength to those produced in X-ray tubes. Gamma radiation is not in the same form as X-rays however and consists of one or more discrete wavelengths in what is known as a 'line spectrum'. The relative intensities of each wavelength are always the same for a particular material. The four most commonly used isotopes are Cobalt 60, Iridium 192, Caesium 137 and Thulium 170.
- 2.3.2 **Radioactive Decay.** Radioactive elements, whether natural or artificial, are subject to a specific rate of decay i.e. a reduction in strength of the radioactivity. This decay is measured in terms of the time over which half the original activity is lost and is called the 'half life' of the material. The half life of radioactive materials varies considerably, for example, Aluminium 28 has a half life of 2.27 minutes whereas Uranium 238 has a half life of 4.5×10^9 years. Radioactive materials can be used for radiography through several half life periods provided that an adequate working strength remains and some are capable of re-irradiation in an atomic pile.
- 2.3.3 **Penetrating Power.** It is customary to express the penetrating power of gamma rays in terms of the voltage which would be required to generate X-rays of similar penetrating power. The unit used, the mega electron volt (MeV), represents the energy required to accelerate an electron through 1 000 000 volts. The energy emitted by Caesium 137 is 0.66 MeV and this is equivalent in penetrating power to the X-rays generated at 660 kV by an X-ray set. Due to the differences in the radiation spectra of the two sources, however, gamma ray sources, which do not generally emit the longer wavelengths, have a mean penetrating power somewhat higher than X-rays.
- 2.3.4 **Gamma Ray Sources.** Radiographic gamma ray sources consist of a circular disc or cylinder of radioactive material encased in a sealed aluminium or stainless steel capsule. The capsule is kept in a container which acts as a storage safe and may also be used as a support during exposure. The container is made of a material, such as lead or depleted (non-radioactive) uranium, which will substantially reduce the emission of gamma rays. High intensity sources are kept in bulky, heavily shielded containers, exposure being achieved by positioning the source opposite a restricting aperture in the container. Some users employ an exposure head connected to the container by guide tubes, the isotope being positioned and controlled by a remote control device. Since gamma rays cannot be turned off, strict regulations have been

devised to safeguard both operators and general public during the transportation and use of radioactive sources.

3 Photographic Aspects

3.1 X-ray Film

- 3.1.1 The films used in radiography are very similar to those used in photography except that the emulsion covers both sides of the flexible transparent base. The emulsion is sensitive to X-rays, gamma rays and light and when exposed to those radiations a change takes place in its physical structure. When treated with a developer, a chemical reaction results in the formation of black metallic silver; it is this silver which, comprises the image. Handling of the undeveloped film is normally carried out in a 'dark room' which is illuminated by subdued yellow light.
- 3.1.2 Film is supplied in two classes, depending on whether fluorescent intensifying screens are to be used or not. Within these classes, film is available in a wide range of speeds and grain sizes.
- 3.1.3 Where the high clarity of a normal film is unnecessary, for instance when searching for debris or checking for correct assembly of a component, certain types of photographic paper can be used, with a consequent saving in cost.
- 3.1.4 Film is normally prepared for exposure by placing in a cassette which may be either rigid or flexible, or in a light-proof envelope. For many applications film is also prepared in roll form, an example of which would be the film used for taking radiographs of a complete fuselage former. An X-ray tube which emits a 360° beam is located in the centre of the fuselage and a roll of film placed to encircle the fuselage.

3.2 Intensifying Screens

- 3.2.1 It is sometimes necessary to take a radiograph of a thick or dense material, necessitating a very long exposure time. This time may be reduced by converting the energy of the X-rays or gamma rays into another form of energy to which the film emulsion is more sensitive.
- 3.2.2 Phosphor coated screens (known as 'salt' screens) will fluoresce in the presence of X-rays and if in contact with the X-ray film, will supplement the image formed by X-rays during exposure. The disadvantage of this arrangement is that the screen imparts a grainy appearance to the film and detracts from image sharpness. 'Screen' type film must be used in conjunction with fluorescent intensifying screens.
- 3.2.3 Metal foil screens are usually made of lead and assist the normal X-ray exposure by producing photo-electrons in the presence of X-rays. This intensifying effect is only evident at potentials above 120 kV, but since the lead screens also reduce scattered radiation and are not granular in manufacture, they are always used in radiography carried out at energies above this value.
- 3.2.4 It is essential that both types of screen are held in close contact with the film (on both sides), as any gap will result in a spread of light (or photo-electrons) and produce a blurred or fogged image. Absolute cleanliness of the screen is also essential, since any dust or grease between the film and screen will be reproduced on the radiograph.

3.3 Sensitivity

- 3.3.1 The darkness of a radiograph depends on the quantity of radiation penetrating the specimen; the thicker the specimen, the lighter will be the image. Defects such as a crack or gas hole will show up as dark areas on the radiograph, since they will give less resistance to the rays. However, the ability to recognise a defect will depend on

its size and the quality of the radiograph. The sensitivity of the radiograph is normally measured by an image quality indicator (IQI), also known as a penetrameter (Figure 2), but this should not be used as a means of calculating the smallest size of defect which may be detected. The shape of the defect and the plane in which it lies are most important; if a crack runs in a plane normal to the X-ray beam it will probably not be detected and this must be taken into account when establishing a technique for a particular inspection.

- 3.3.2 Ideally IQIs should be made of the same material as the radiographic subject, but in practice mild steel is suitable for all steel specimens, pure aluminium is suitable for all aluminium alloys and copper is suitable for most bronzes and brasses. The IQI should be placed on the upper surfaces of the area undergoing radiography, i.e. nearest to the beam source, so that it will appear on the radiograph. The thickness of the last detectable step (or wire) should be ascertained and expressed as a percentage of the specimen thickness.
- 3.3.3 It will be appreciated that the difference in the sizes of the steps or wires in the IQIs shown in Figure 2 must be very small for use with aircraft structures. In fact, although the use of IQIs is essential with thick specimens, the very nature of aircraft structures, comprising skins, ribs, stringers, paint, sealant, etc., is an adequate form of IQI for most radiographic needs.
- 3.3.4 The step-wedge IQI (Figure 2(a)), consists of a number of steps ranging in thickness from 0.005 in to 0.1 in or greater as required. Each step contains a number of holes, varying in size according to the step thickness and these are used both for identification of the step and as an indication of image sharpness.
- 3.3.5 The wire IQI (Figure 2(b)), consists of a series of short lengths of wire in graduated diameters, embedded in thin rubber or plastic sheet. This type of IQI is sensitive to both sharpness and contrast, particularly in the smaller sizes.
- 3.3.6 Variations of the standard IQI are sometimes used for special purposes, e.g., when searching for fatigue cracks an IQI containing a typical defect could be used (Figure 3). The IQI is placed on the surface of the member being examined and, provided that the simulated defect is clearly visible on the radiograph, it can be assumed that any other crack of similar size and orientation would also be visible.

3.4 Geometric Considerations

- 3.4.1 The sharpness of a radiographic image is influenced by the film characteristics and by geometric effects, which, since they are to a large extent under the control of the radiographer, are very important. The factors involved are the size of the radiation source, the distance between the source and the film and the distance between the specimen and the film; these factors are illustrated in Figure 4.
- 3.4.2 It is generally accepted that a radiographic image viewed by the naked eye will appear to be sharp if the blurring of edges does not exceed 0.025 centimetres (0.01 inches). The blurring, or sharpness, is caused by the finite size of the radiation source and this is quoted in the specification for the equipment concerned or can be found by experiment. From Figure 4 it can be seen that the closer the film is to the specimen then the sharper will be the image. However, practical considerations may prevent contact between the film and specimen and in this case acceptable sharpness can only be obtained by increasing the source-to-film distance. Alternatively, better coverage of a large or irregularly shaped part may be achieved by taking several radiographs from different angles, thus keeping the object-to-film distance to a minimum.

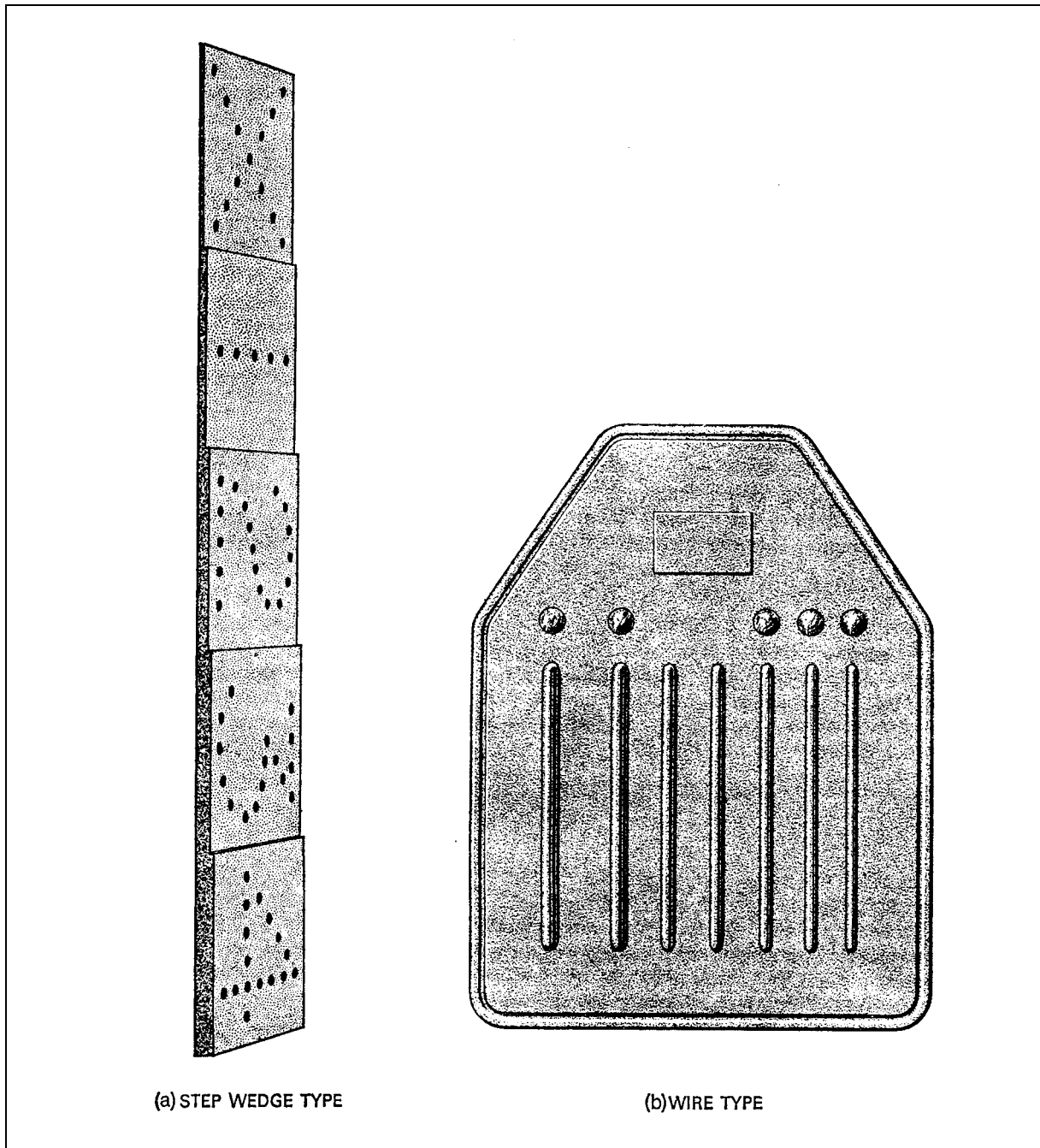

Figure 2 Standard Image Quality Indicators

3.5 Exposure Conditions

- 3.5.1 The quantity of radiation affecting an area of specified size varies inversely as the square of the distance from the source; if the source-to-film distance is increased the exposure time must be increased accordingly. The ideal situation would obtain where the cone of radiation just covered the film area.
- 3.5.2 The required exposure conditions could be obtained by the use of exposure charts and calculations dependent on film characteristics. However, since a number of variables exist, it is more usual to establish a technique from knowledge of the structure involved, study of the aircraft manufacturing drawings and systematic trial and error methods. Once the geometric considerations have been determined, a series of radiographs is usually taken, systematically varying the voltage, exposure time and occasionally the tube current or type of film, until an acceptable radiograph

is produced. A double film technique is often used to reduce the number of exposures required. The lowest useable kilovoltage gives the highest contrast thus making recorded defects more distinct.

3.6 Filtration

- 3.6.1 When a beam of radiation passes through a material, some passes directly through (the primary radiation) and some is scattered by collision with the atoms making up the material (the scattered radiation). The primary radiation is the true image forming energy, but the scattered radiation results in a fogging effect on the film, reducing contrast and impairing definition. While scattered radiation is always present, its effects can be reduced by the use of metallic screens, masks or backing.

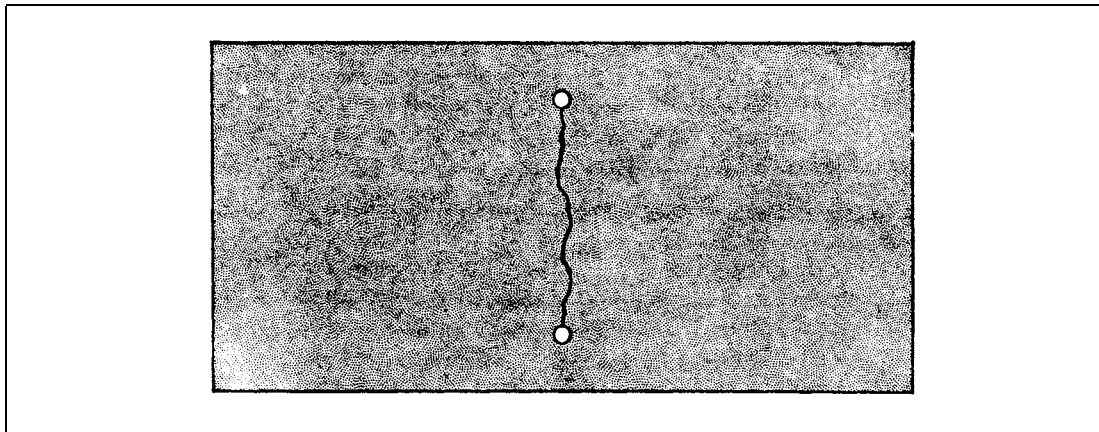

Figure 3 IQI Simulating a Defect

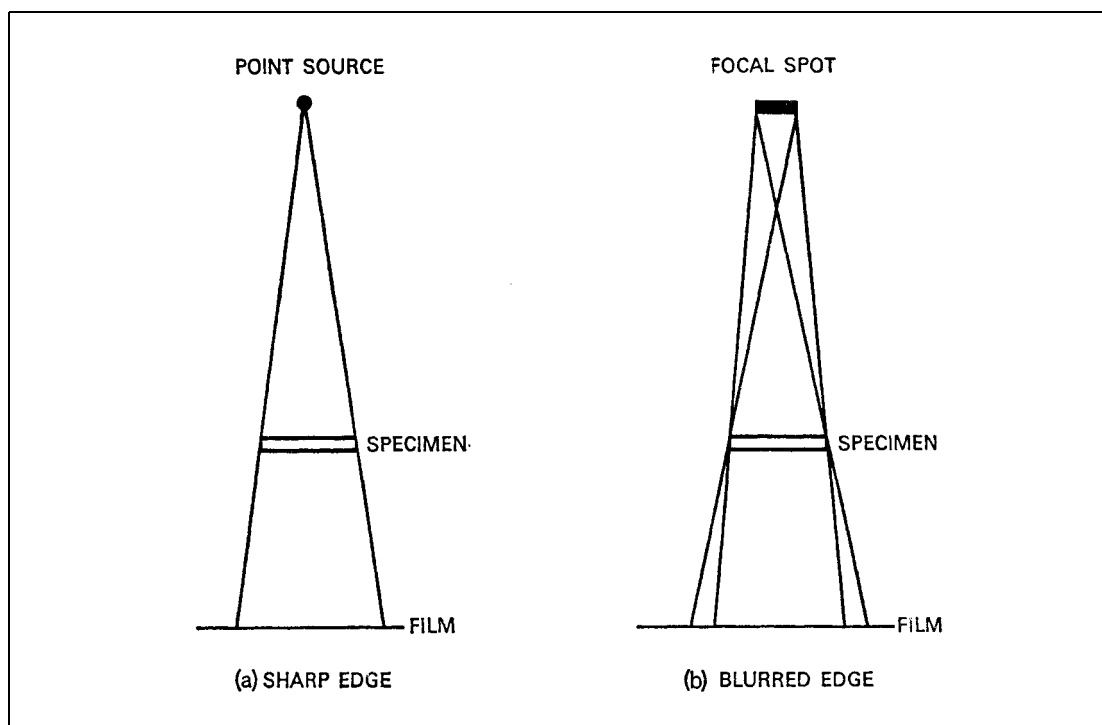

Figure 4 Geometric Unsharpness

- 3.6.2 **Primary Beam Filtration.** X-rays consist of a wide band of wavelengths, the shorter of which are the image forming radiations. The longer wavelengths have little penetrating power but are a significant source of scattered radiation and can normally be eliminated from the X-ray beam by placing a metal filter close to the X-ray source.

The thickness of the filter is important since it affects the total material to be penetrated and it is usually found by experiment; a copper filter 0.1 mm thick would normally be used with a 100 kV to 200 kV set.

- 3.6.3 **Scatter Within the Specimen.** Some scattered radiation is generated within the specimen, particularly when it consists of a box-like structure, or dense material. This may be reduced by placing a filter, similar to that used for the primary beam, immediately above the film. Particular care is necessary to ensure that this filter is clean, since any dirt will show up on the radiograph. In the case of light alloy structures a limitation of 2 minutes exposure time will usually eliminate such scatter.
- 3.6.4 **Masks and Backing.** Scattered radiation can be produced from any point within the area of coverage of the radiation beam and will, therefore, be produced by structure situated beside or behind the film. This radiation is reduced by placing lead sheets adjacent to the film and specimen, immediately at the back of the film and in permanent radiographic rooms, by covering the floor and table with lead. With irregularly shaped specimens an opaque paste mask is sometimes used.

4 Radiographic Techniques

- 4.1 The establishment of completely reliable techniques of examination is essential if confidence is to be placed in the resulting radiographs. It may be necessary to prove their effectiveness initially by dismantling the particular structure to ensure that no defects exist which have not been revealed in the radiographs and to determine that the radiographs have been correctly interpreted.
- 4.2 The factors outlined in paragraph 3 should be taken into account in evolving a satisfactory radiographic technique and a record should be kept of the conditions under which the technique was established. A typical Radiographic Technique sheet, as recommended in British Standard M34, is reproduced in Figure 5. This sheet should be given a number for identification purposes and should also include, in the 'Notes' section, such details as items which must be removed (including fuel from the fuel tanks, radiation sensitive items, sealant or paint, etc.), any jacking or trestling necessary and measurements from which the film, X-ray set or isotope may be positioned. A simple isometric drawing may also assist identification of an area under examination and the inclusion of photographs or drawings showing potentially defective items should also be considered.
- 4.3 It may often be necessary to penetrate a widely varying range of thicknesses and, if only a single radiograph is taken, this may result in the appearance of greatly contrasting light and dark areas, making accurate interpretation almost impossible. In such circumstances the simultaneous exposure of two or three films without intervening wrapping in a common cassette or envelope may be employed; if the films and exposure time are carefully selected, each different thickness will be shown at a suitable density on one of the radiographs. The use of a lead screen separating two films is sometimes useful in achieving satisfactory radiographs of different material thicknesses and also gives greater flexibility in the selection of a film pack.

5 Gamma Rays in Aircraft Radiology

- 5.1 In general it may be considered that the majority of radiographs of aircraft structures are taken with an X-ray set. This is due to the unsharpness and lack of contrast normally obtained with gamma sources and the gradual decrease in radiated energy. However, there are occasions when a gamma source is used, mainly due to lack of space or access for X-ray equipment.

Figure 5 Typical Radiographic Technique Sheet

(Company name and address)																				
Set used:		RADIOGRAPHIC TECHNIQUE SHEET				Sheet..... of.....sheets		Technique sheet No.												
Type of radiation:		Description																		
Source size:		Purpose of inspection:																		
		Area to be inspected:																		
		Acceptance standard:																		
Preparation:		Associated documents				Prepared by:		Date:												
		BS M.34				Approved by:		Date:												
Exposure details																				
Aspect or position	Angle of beam to film	s.f.d	kV	mA	Time	Filters		Screens	Ug	Film										
						on tube	on film													
NOTES:																				

- 5.2 **Application.** By the use of guide tubes or handling rods attached to containers, it is often possible to place isotopes in positions which would be completely inaccessible to X-ray equipment. An example of this is where an internal portion of a structure is to be examined, there being no means of access for the X-ray equipment and the complexity of the structure precluding the taking of X-ray pictures from the outside. Provided it is possible to place the film in position, the isotope can be inserted through a convenient aperture and a direct radiograph of the particular area may be obtained.
- 5.3 Isotopes are also often used for the examination of internal features of turbine engines, such as the main rotor shaft and provision of access points is sometimes included in the engine design.
- 5.4 **Isotopes.** The types of isotope used will be determined by the thickness of the subject, the source-to-film distance and the source output in terms of exposure time.

6 Fluoroscopy

- 6.1 The luminescent property of phosphors enables them to transform X-rays into visible light. The effect is most pronounced with low energy X-rays, normal gamma ray sources are therefore unsuitable, being of too short a wavelength.
- 6.2 X-rays are passed through the specimen and impinge on a phosphor coated screen which emits light in proportion to the intensity of the X-radiations falling on it. A positive image is formed on the screen, showing internal details of the specimen in a similar manner to a radiograph.
- 6.3 Viewing cabinets are so manufactured that the observer is protected from harmful radiations. Where low energy radiations are used the phosphor screen is viewed directly through a lead glass window but when high energy X-rays are necessary it is usual for an angled mirror to be interposed so that the screen is viewed at an angle to the primary X-ray beam.
- 6.4 Due to the coarse grain of the phosphor screen and the poor geometric sharpness resulting from the need to place the screen close to the X-ray source, fluoroscopic images are greatly inferior to those produced by radiographs; for this reason fluoroscopy is seldom used in aircraft work. However, one big advantage of fluoroscopy is that there is no film to be developed and the method is suitable for checking the correct assembly of components or inspecting for debris in aircraft. In general engineering fluoroscopy is also used in conjunction with image intensifiers, for the examination of welded tube and other simple structures.

7 Viewing Conditions

- 7.1 In order to recognise all the indications available on a good radiograph, it is essential that suitable viewing conditions are provided.
- 7.2 Ideally, radiographs should be examined in a room set aside for this purpose and situated away from distracting conditions such as a high noise level. The room should be capable of being darkened but, during viewing, should have a low intensity background light which does not reflect on the film.
- 7.3 The viewing of radiographs requires a good deal of concentration. It is recommended that continuous viewing periods should not exceed 90 minutes and should be followed by a period of at least 30 minutes doing associated work away from the viewing area.

- 7.4 The radiograph itself should be placed on a special viewing box where it can be illuminated from the back, preferably by diffused lighting. Any light appearing round the edge of the radiograph should be masked off since it would tend to dazzle the viewer, possibly resulting in fine defects in the denser parts of the radiograph being overlooked. Controllable shutters are usually provided on the viewing box for this purpose. In addition, the masking of light areas of the radiograph while viewing dark areas will increase the apparent contrast of the image. Where the radiograph has areas of widely differing density the provision of a dimming control may assist the viewing of very light areas.
- 7.5 In some instances it may be advisable to make use of a magnifying glass for the examination of fine detail, but a glass with high magnification should not be used.

8 Interpretation of Radiographs

8.1 The accurate interpretation of the defects indicated on a radiograph is a matter which requires considerable skill and experience and, if the maximum benefits are to be obtained from radiography it is essential that the viewer should have an intimate knowledge of the aircraft structure. Without such knowledge it would be possible to overlook faults which would be obvious to an engineer, e.g. distorted or missing parts. Interpretation of radiographs can be considerably simplified if radiographs of a sound structure are available as standards, for comparison with radiographs on which defects are recorded. For simple structures an isometric drawing of the area might be suitable. Some of the indications obtained on radiographs are described in the following paragraphs.

8.2 Castings and Welds

8.2.1 Metallurgical defects in castings and welds generally produce characteristic patterns which may be recognised by an experienced viewer. Porosity, for example, will reduce the amount of material through which the X-rays or gamma rays must pass and result in dark spots in the film, whereas segregated constituents of alloys, or inclusions, may be light or dark, depending on their relative density.

8.2.2 Cracks in welds may be difficult to detect and knowledge of the defects associated with the particular type of weld is essential. The angle at which the radiograph is taken is of particular importance, since defects in a plane normal to the radiation beam would not result in any significant change of density in the emulsion. Surface blemishes produced by welding are recorded on the radiograph and produce a complex image liable to misinterpretation.

8.3 Corrosion

8.3.1 The detection of corrosion is invariably difficult, the difficulties often being aggravated by the presence of paint, jointing compound and surfaces fouling which, by their radiographic density, may compensate for the deficiency of material caused by corrosion or give rise to a suspicion of corrosion which does not exist. However, corrosion normally has an irregular and possibly 'fuzzy' outline, while compounds will usually have a regular and sharply defined one. Intergranular corrosion may not be detectable by radiography until it has reached an advanced state and affects the metal surface.

8.3.2 Under laboratory conditions, where scattered radiation can be effectively reduced and ideal exposure conditions obtained, it is possible to detect very small cavities. However, when radiographs of an aircraft structure are being taken, ideal conditions will not normally exist and the size of detectable cavities may be much larger. For

example, fuel tank sealant is particularly dense and it is doubtful if pitting less than 10% to 15% of the total thickness, including the sealant, would be revealed.

- 8.3.3 A corrosion pit giving rise to a sudden change of thickness in a given specimen is more readily visible on a radiograph than a pit of the same depth in the form of a saucer-shaped depression. This is due to the fact that a sudden change in the density level on the radiograph is more easily seen than a gradual merging of two areas of different density.
- 8.3.4 A further difficulty in the detection of corrosion is that the corrosion products often adhere to the surface and the difference in density might be so slight as to be undetectable. In some instances the build up of corrosion products can be detected when the radiograph is taken at an oblique angle to the surface of the metal.
- 8.3.5 In aircraft structures, stress corrosion often has a characteristic appearance, showing up as lines of spots on the radiograph. With experience this condition can be identified from similar indications caused by debris or poor developing.
- 8.3.6 Corrosion can sometimes be detected where successive radiographs, taken over a period of time by an identical technique in each instance, reveal a gradual change in density in a particular area.

8.4 **Cracks**

- 8.4.1 There is a tendency to regard cracks as straight gaps perpendicular to the working surface, but this is not invariably so. Unless appropriate techniques have been used in taking the radiographs, it is possible for fairly large 'dog-leg' cracks particularly in the thicker sections, to remain undetected.
- 8.4.2 Stress cracks around rivets in aircraft structures often have a characteristic appearance, running along a line of rivets in a series of arcs. In certain circumstances the edge of the jointing compound used during wet assembly of rivets can give the appearance of hair line cracks of this type, but masking down to a very small area will reveal the true nature of the indication.
- 8.4.3 When cracks are being sought on the tension side of a wing it is sometimes possible to open up the cracks by applying a tension load, normally by jacking. This will result in a more positive indication on the radiograph.
- 8.4.4 While cracks will normally appear as a darker line on the radiograph, instances may occur when a lighter line is present. This may result from a part, such as a stringer, being cracked right across and overlapping at the point of fracture, thus presenting a thicker section for the rays to penetrate.
- 8.4.5 Many radiographs of structure bear evidence of what appears to be structural cracking but, when such areas are examined physically, the cracks have been found not in the structure but in the sealing or jointing compound used in the area. Such conditions may occur inside integral fuel tanks, but with experience it is possible to distinguish between the two types of cracks by reason of their distinctive shape. Some sealants are very opaque to X-rays and may completely hide a defect.
- 8.5 **Leaded Fuel.** It is often necessary to take radiographs where the primary beam of radiation passes through a fuel tank (e.g. the lower surface of a wing containing integral fuel tanks). Since lead offers considerable resistance to the penetration of X-rays and gamma rays, the presence of even the small percentage of lead contained in most aviation gasolines will restrict the quantity of radiation reaching the film. It is imperative, therefore, that the fuel tanks should be completely drained before the film is exposed. Pools of fuel left in the tanks may also give misleading indications on the

radiograph. Less difficulty is experienced with kerosene but some scatter does occur and may impair the quality of the radiograph.

9 Glossary of Terms Used in Radiography

The following terms and abbreviations are used in radiological non-destructive testing and are taken from a complete list contained in British Standard BS EN 1330-3: 1997.

Ångstrom unit (Å)	Unit of measurement of the wavelength of X-rays and gamma rays. $1\text{Å} = 10^{-8}\text{ cm}$.
Anode	The positive electrode of an X-ray tube which carries the target from which the X-rays are emitted.
Cathode	The negative electrode of an X-ray tube.
Cassette (or cassette)	A light-tight container for holding radiographic film, paper or plates during exposure. Screens may or may not be included.
Contrast	The relative brightness of two adjacent areas on an illuminated radiograph.
Definition	The sharpness of image details on a radiograph.
Density	The degree of blackening of a radiograph.
Focus-to-film	The distance from the focal spot of an X-ray distance (ffd) tube to a film set up for exposure.
Gamma (γ) rays	Electromagnetic radiation emitted by radioactive substances during their spontaneous disintegration.
Grain size	The average size of the silver halide particles in a photographic emulsion.
Image Intensifier	A device used to give a brighter image than that produced by X-rays alone upon a fluorescent screen.
Isotopes	Atoms of a particular element which have the same chemical properties and atomic number, but a different mass number from those normally present in the element.
Penumbra (Ug)	Blurring at the edges of a radiographic image due to the radiation source being of finite dimensions.
Quality	The penetrating power of a beam of radiation.
Radiograph	The photographic image produced by a beam of radiation after passing through a material.
Resolution	The smallest distance between recognisable images on a film or screen.
Source-to-film distance (sfd)	The distance from the source of primary radiation to a film set up for exposure (i.e. ffd related to gamma source).
Tube current	The current passing between the cathode and the anode during the operation of an X-ray tube.

Tube head	A type of X-ray shield which, in addition to the X-ray tube, may contain part of the high voltage generator.
Unsharpness	Image blurring caused by the penumbra, by movement, by grain size, or by light, electron or X-ray scatter.
X-rays	Electromagnetic radiation resulting from the loss of energy of charged particles (i.e. electrons).

Leaflet F-70 Magnetic Flaw Detection

1 Introduction

- 1.1 This Leaflet provides guidance and advice on the detection of surface and sub-surface defects in ferro-magnetic materials by magnetic processes. The procedures recommended in this Leaflet are complementary to British Standard BS EN ISO 9934 1: 2001 and should not be taken as overriding the techniques of examination prescribed by the manufacturer of a particular component, either in drawings or in approved manuals.
- 1.2 Magnetic flaw detection tests are applied to many steel parts at the manufacturing, fabrication and final inspection stages. The process is normally applied to all Class 1 aircraft parts manufactured from ferro-magnetic materials and to any other parts where the designer or inspection authority considers it to be necessary.
- NOTE:** A Class 1 part is defined as a part, the failure of which, in flight or ground manoeuvres, would be likely to cause catastrophic structural collapse, loss of control, power unit failure, injury to occupants, unintentional operation of, or inability to operate, essential services or equipment.
- 1.3 The methods of magnetising in general use are the magnetic flow and the current flow processes, which are described in paragraph 3. By choosing the most suitable process, or combination of processes, for a particular component, both surface and subcutaneous defects may be revealed.
- 1.4 Great care must be taken when establishing a technique of examination suitable for a particular component, in order to ensure that consistent results are obtained. Operators of magnetic flaw detection equipment should be thoroughly trained in its use and experienced in interpreting technique requirements and the indications obtained from a test.

2 The Principle of Magnetic Flaw Detection

- 2.1 If a component is subjected to a magnetic flux, any discontinuity in the material will distort the magnetic field and cause local leakage fields at the surface. Particles of magnetic material applied to the surface of the magnetised component will be attracted to the flux leakage areas and reveal the presence of the discontinuity.
- 2.2 The sensitivity of magnetic flaw detection depends largely on the orientation of the defect in relation to the magnetic flux and is highest when the defect is at 90° to the flux path. Sensitivity is considerably reduced when the angle between the defect and the flux path is less than 45°, so that two tests are normally required with each component, the flux path in the first test being at 90° to the flux path in the second test. Components of complex shape may require tests in several different directions.
- 2.3 A component may be magnetised either by passing a current through it, or by placing it in the magnetic circuit of a permanent magnet or electromagnet. The required strength of the applied magnetic field varies considerably and depends largely on the size and shape of the component and on the magnetic characteristics of the material from which it is made.
- 2.4 The magnetic particles used to reveal defects are either in the form of a dry powder, or suspended in a suitable liquid. They may be applied by spray, pouring, or immersion, depending on the type of component. Magnetic flaw detection 'inks'

complying with BS EN ISO 9934-2: 2002 are used in aircraft work and consist of finely divided black or red magnetic oxides of low coercivity (i.e. they will not retain the magnetism induced during testing), suspended in a liquid (normally kerosene). Pigments may be added to provide a contrast with the surface of the specimen. Black inks are suitable for use on bright, machined components, but red inks may be more suitable for unmachined parts or, alternatively, a thin coat of white paint or strippable lacquer may be added to the component before carrying out the test.

- 2.5 If magnetic inks are left standing for long periods the solid particles settle at the bottom of the container and form a sediment which may be difficult to redisperse. If the machine does not have pump agitation, frequent manual agitation must be provided during tests to ensure satisfactory inking of the specimens. The solids concentration in inks manufactured to BS EN ISO 9934-2: 2002 should be 0.8% to 3.2% by volume, but with fluorescent inks the solids content is approximately one tenth of these values. Methods of determining the solids content of magnetic inks are detailed in BS EN ISO 9934-2: 2002. Magnetic ink should be discarded if it becomes diluted by solvents or contaminated with oil or any foreign substance likely to reduce its effectiveness as a detecting medium.
- 2.6 Fluorescent inks are also widely used and are often specified where high sensitivity is required. Inspection of a component to which fluorescent ink has been applied, should be carried out under black light.

3 Methods of Magnetisation

3.1 Current Flow Method

- 3.1.1 If an electric current is passed through a conductor, a magnetic flux is induced, both within the conductor and in the surrounding atmosphere, in a series of concentric circles at 90° to the direction of current flow. With steady current, the strength of the internal magnetic flux is greatest at the surface of the conductor and decreases uniformly to zero at the centre, but with alternating current both the current and magnetic flux are confined to a thin layer at the surface, because of the effects of induction. Magnetisation at the surface can be greater with alternating current than with direct current, but direct current has the advantage of greater depth of penetration. In practice, machines are often designed so that alternating or rectified current can be applied to a specimen, to make use of the advantages of each method.
- 3.1.2 Current flow machines normally provide a sustained current through the specimen, ink being applied while current flows. The specimen is usually clamped between contact pads on a static machine, but portable units are available in which the contacts take the form of hand-held prods and these are often used for checking components which are difficult to mount in a static machine. Good electrical contact is essential and the contacts are usually provided with copper gauze pads, sufficient pressure being used to prevent arcing between the pads and the specimens. Because of the dangers of burning and possible subsequent fatigue cracking, the use of prods is often prohibited on finished parts, especially those of high tensile steel.
- 3.1.3 A variation of current flow magnetisation is the 'impulse' method, which employs either direct or alternating current in the form of a short impulse (generally less than one second). Difficulty may be experienced in satisfactorily inking the specimen while current is flowing and the specimen may be immersed in a bath of magnetic ink. Alternatively, with some materials, remanent magnetism may be sufficiently strong to provide defect indications when ink is applied after current has ceased to flow. The alternating current impulse method is not often used, due to the difficulty of interrupting the current at a point in the hysteresis loop which will leave the specimen adequately magnetised.

- 3.1.4 For testing purposes it is usual to apply a sufficiently heavy current to give a satisfactory magnetic flux in the specimen and to use a low voltage to safeguard the operator. As a rough guide to the basic current setting to use, most steels can be satisfactorily tested using an alternating current of 500 A rms per inch diameter or, for specimens of irregular shape, 150 A rms per inch of periphery. Some steels, e.g. nickel-chrome steels, may require a higher magnetising force due to their low permeability. Current values for irregular shaped components should be decided by fixing an artificial defect to the area required, applying ink and varying current value until a satisfactory indication is obtained.

NOTE: The effective current value with regard to magnetisation is the peak value. Ammeters do not usually record the peak value however and testing techniques must state whether the current values specified are rms (root mean square) or peak. It is normally assumed that an ammeter reading rms is fitted to an a.c. machine and an ammeter reading mean current is fitted to a rectified a.c. or constant potential d.c. machine. Current values producing a magnetic flux equivalent to that produced by 500 A rms, a.c., with these types of ammeter fitted, are:

d.c.	– 710 A
half-wave rectified a.c.	– 225 A
full-wave rectified a.c.	– 450 A

If a peak-reading ammeter is fitted to an a.c. machine, the current value should be the same as for d.c. (i.e. 710 A). In cases where the wave form is unknown, the relationship between peak and average values must be determined empirically and the current adjusted accordingly.

- 3.1.5 The passage of a heavy current will have a heating effect on the specimen, particularly when direct current is used. This could cause burning in specimens such as thin tubes and possibly have an adverse effect on any heat treatment previously applied. The duration of each test should, therefore, be limited to as short a time as possible, consistent with satisfactory inking of the specimen.

3.2 Induction Methods

- 3.2.1 In all induction methods, the magnetic field external to the current-carrying element is used to induce a magnetic flux in the specimen.

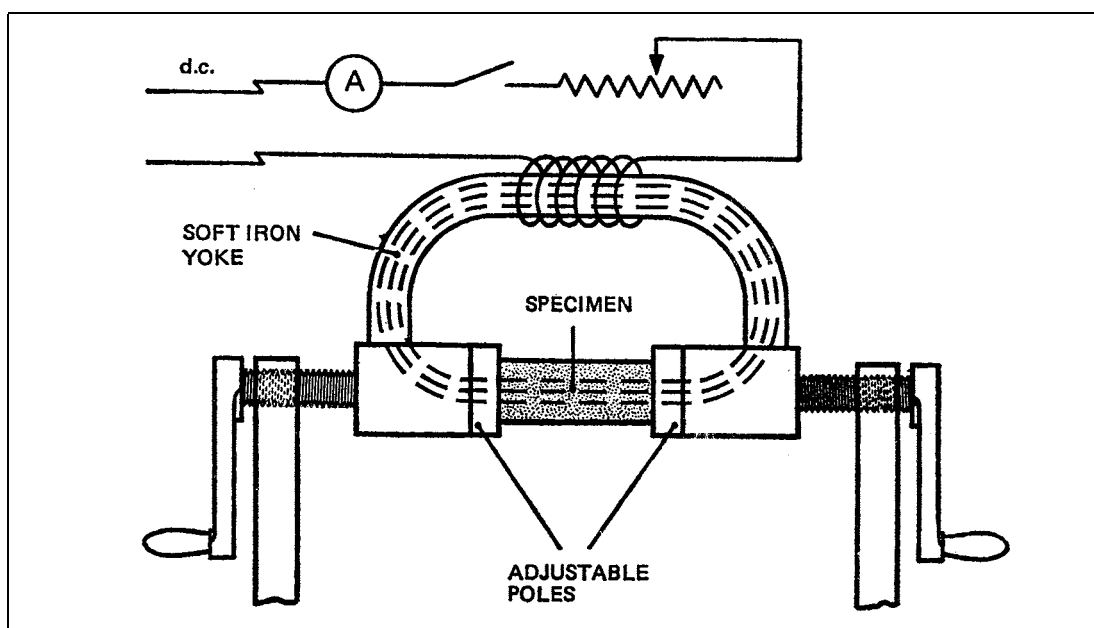

Figure 1 Magnetic Flow Machine

3.2.2 **Magnetic Flow Method.** Figure 1 shows the arrangement of a typical magnetic flow machine, the specimen being clamped between adjustable poles in the magnetic circuit of a powerful electromagnet. Good contact between the poles and specimen is essential, otherwise a marked lowering of the field strength will result. Laminated pole pieces are often used to ensure that good contact is maintained with specimens of curved or irregular shape and in some portable equipments which employ a permanent magnet, contact is obtained through a number of spring-loaded pins.

- a) The magnetising force required to carry out a test using a magnetic flux machine, will depend on the length, cross-section and permeability of the yoke, the number of turns of the windings and the magnetic characteristics of the test piece. No set current value would be suitable with all machines and tests should be conducted to ascertain the current value which will ensure magnetisation just below the saturation level. Saturation is indicated by a heavy build-up of magnetic ink at the ends of the specimen, or an overall coating on its surface. In all tests the cross-sectional area of the pole pieces should be greater than that of the specimen, but the maximum cross-sectional area which can be tested will normally be stated in the operating instructions for a particular machine.
- b) To ensure that the strength of the magnetic flux in a specimen is sufficient to reveal defects during a test, it is common practice to employ portable flux indicators. These may take the form of thin steel discs containing natural cracks, which, when attached to the surface of a specimen during a test, will give an indication of flux strength and also, with some indicators, the flux direction.
- c) With many machines it is easy to over-magnetise, particularly when carrying out tests on small specimens. If the machine does not have controls for adjusting the energising current, a reduction in magnetic flux can be achieved by inserting non-magnetic material between the pole pieces and the specimen.

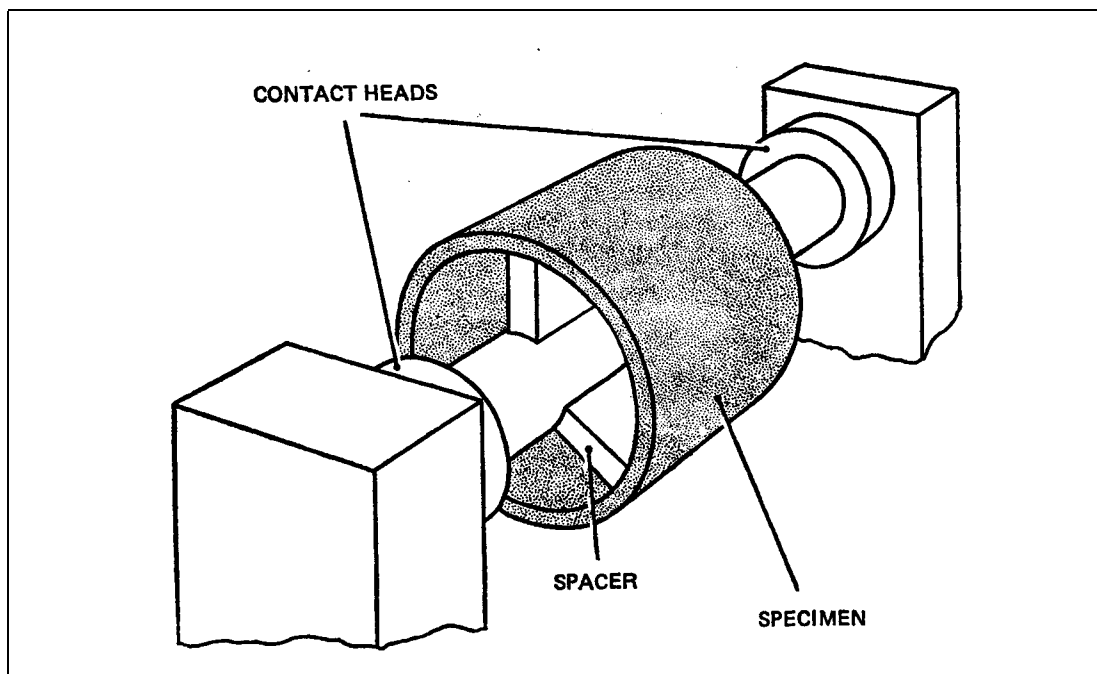

Figure 2 Threading Bar Method

- d) Magnetic flow machines are generally designed to operate with direct current, the magnetising coil containing a large number of turns of wire and carrying a current of a few amps only. This type of coil would be unsuitable for use with alternating

current, since the coil would have too much inductance. If it is required to use alternating current for magnetic flow tests, the coil must be replaced by one having a few turns and carrying a heavy current.

3.2.3 Threading Bar Method. This method is used for testing rings and tubes and is illustrated in Figure 2. A current flow machine is used and a conductor connected between the contact heads of the machine. Current flowing through the conductor induces a magnetic flux in the specimen at 90° to the direction of current flow; this flux may be used to reveal defects in line with the axis on the specimen. Best results are obtained when the air gap is smallest, i.e. the conductor is only slightly smaller than the internal diameter of the specimen, but a larger air gap is often necessary in order to permit examination of the interior surface.

- a) A symmetrical flux may be obtained in the specimen by inserting non-conducting spacers between the conductor and the specimen, but this is not essential except to prevent burning should the conductor overheat. If the shape of the item undergoing test precludes the use of a straight conductor, a heavy flexible cable may be used.

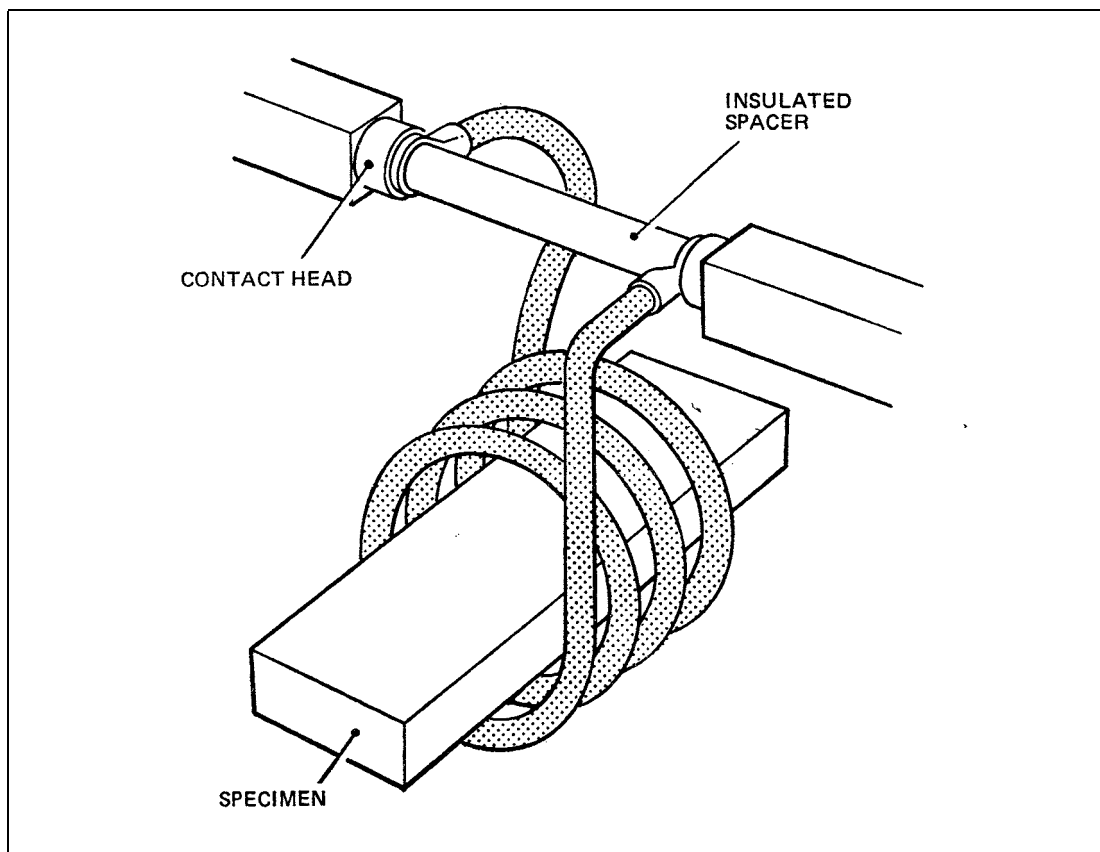

Figure 3 Magnetising Coil Method

- b) The basic current setting should be determined from the length of the flux path, i.e. the outside periphery of the specimen, 100 to 200 amps per inch being a satisfactory basic setting for most steel specimens. The current required is unaffected by the length of the specimen, except that if the specimen is very long the resistance of the conductor may limit the available current.

3.2.4 Magnetising Coil Method. A current flow machine is also used for the magnetising coil method. An insulated heavy gauge copper wire or strip is connected between the contact heads of the machine as shown in Figure 3 and formed into a coil; a.c. coils

have 2½ to 4 turns and d.c. coils 6 to 10 turns, the space between turns being less than the cross-sectional diameter of the wire in order to minimise flux leakage. The magnetic lines of force resulting from passing current through the coil, will induce a magnetic flux in the specimen, in the direction of the coil axis.

- a) Components of simple shape may be placed within the coil during a test, but satisfactory magnetisation will only be obtained within the length of the coil. Difficulty may be experienced with short components, due to the de-magnetising effect resulting from the close proximity of the free poles (i.e. the ends of the specimen) and it is often advisable to complete the magnetic circuit using a yoke manufactured from mild steel, or extend the effective length of the component with end blocks.
- b) When components of complicated shape are being tested, it is difficult to estimate the strength and direction of the magnetic flux in all parts of the specimen during a single test. It is often preferable to make several tests with the coil located at several positions within or around the specimen, inspecting only those parts adjacent to the coil at each position.

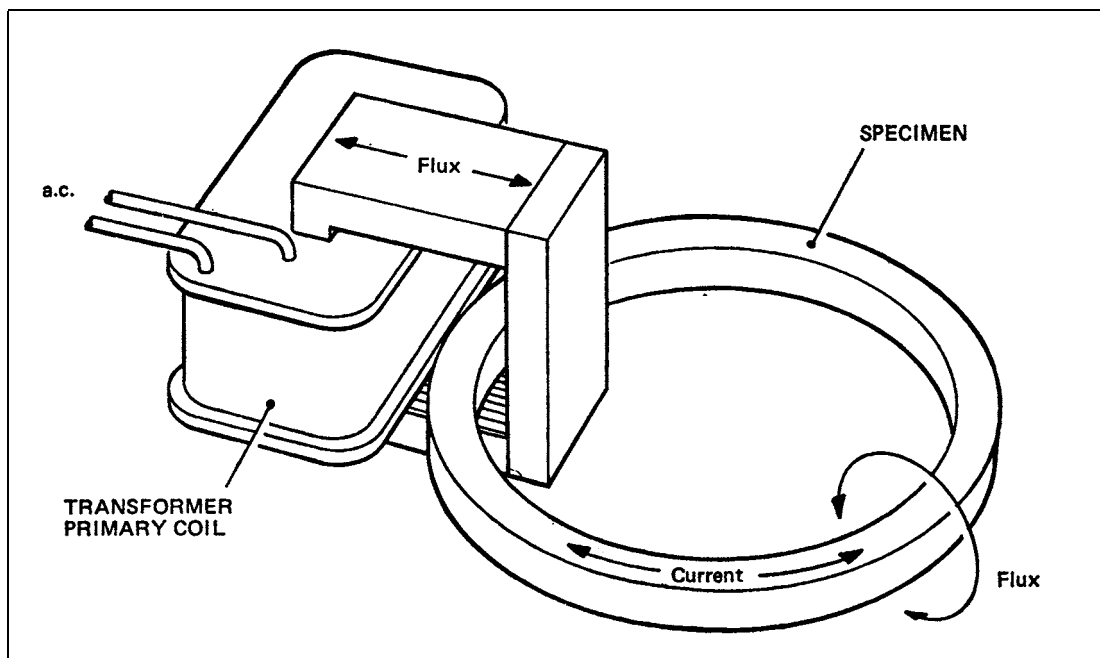

Figure 4 Induced Current Flow Method

- c) As with the magnetic flow method, the current required depends on a number of factors, including the relative diameters of the specimen and coil and the length/diameter ratio of the specimen. BS 6072: 1981 gives a formula for calculating the current required under specified conditions, but the most suitable values are generally obtained by experiment and by selecting a current which gives a field strength just less than that required to saturate the material.

3.2.5 Induced Current Flow Method. Figure 4 shows the coil arrangements for this method, in which current is induced to flow through the specimen by the action of the primary coil of a transformer. The induced current itself provides a magnetic field within the specimen, which may be used for detecting defects lying mainly in a longitudinal direction. This method is often used on ring specimens of large diameter.

4 Testing Procedures

4.1 Techniques of testing by magnetic methods are established after preliminary tests have shown that defects can be consistently revealed in similar parts to those under test. When carrying out routine tests in accordance with a specified technique, each instruction must be carefully followed in order to obtain satisfactory results. The full test procedure consists of degreasing, magnetising, application of magnetic ink or powder and interpretation of indications, this process being repeated for each test specified on the technique sheet and concluding with final demagnetising and cleaning. The use of a hand lens of low magnification is normally specified for the examination of defects.

4.2 General Considerations

4.2.1 Before carrying out a test the equipment should be checked to ensure that it is functioning properly. The technique sheet (see paragraph 5) will usually specify the capacity of the machine required for a test and stipulate the type of magnetic ink or powder to use. An initial test, using a specimen containing known defects, may be carried out to verify that these defects can be revealed. Alternatively, in the absence of a cracked specimen a test may be carried out using a 'portable crack' taped to the surface of the specimen. This often consists of a thin strip of material in which a crack has been artificially induced and may be used as a guide for acceptance or rejection of the specimen under test. Equipment is usually checked with standard test pieces.

4.2.2 Good lighting is essential for examining the specimen. Good daylight provides the best illumination for normal inks, but fluorescent lighting, free from highlights and of correct intensity, is a suitable substitute. When using fluorescent inks, black light is essential and daylight should, as far as possible, be excluded from the viewing area; efficiency of the black light source should be checked periodically (BS EN ISO 3059:2001).

4.2.3 Adequate bench space should be provided adjacent to the testing machine and, where the nature of the work permits, should be away from noisy or otherwise distracting locations.

4.2.4 When specimens are tested in batches and set aside in a magnetised condition for subsequent examination, they should not be permitted to come into contact with one another, or with any other magnetic material, such as steel-topped benches or steel brackets, until the examination has been completed. If specimens do come into contact with other magnetised objects a local dis-arrangement of the magnetic field may occur, giving an effect similar to that obtained with a real defect.

4.3 Selection of Method

4.3.1 In cases where a technique of examination has not been specified, tests must be made to ensure that defects in the specimen can be satisfactorily revealed.

4.3.2 Factors to be considered are the size and shape of the specimen and the capacity of the machines available. Changes of cross-section in a component will result in variations in the intensity of magnetisation through the component, requiring several tests using different current settings at each change of cross-section. The shape of a component may also modify the distribution of magnetic flux and result in misleading indications in the ink pattern. Examples of difficult specimens are toothed gears, turbine blades with fir tree roots and threaded components, where over-magnetisation may result in build-up of iron oxide at the extremities and cause defects to be hidden. This type of component may often be examined using a remanent magnetism technique, a d.c. supply being used with fluorescent ink; the part should be gently swilled in paraffin after application of the ink to clear the background, but retain any defect indications.

- 4.3.3 Since the majority of specimens must be tested for longitudinal and transverse defects, both current flow and magnetic flow tests are normally required; both tests may be carried out on a single universal machine.
- 4.3.4 Table 1 gives guidance on the most suitable methods of testing materials of various simple shapes; components of complicated shape may require special techniques. Tests using flux detectors and portable cracks will usually permit a satisfactory technique to be established however and great difficulty is not often experienced.

Table 1

Specimen	Suitable Test Methods
Bar	Current flow for longitudinal defects. Magnetic flow for transverse defects.
Tube	Magnetising coil for transverse defects. Threading bar for longitudinal defects. Magnetic flow for transverse defects. Current flow for longitudinal defects. Magnetising coil for turnovers defects.
Ring	Threading bar for defects in line with ring axis, and radial defects. Current flow or induced current flow for circumferential defects.
Plate	Current flow or current flow using prods for both longitudinal and transverse defects.
Disc	Current flow or current flow using prods, with the disc rotated 90° between successive tests.
Sphere	Current flow or current flow using prods, sphere being rotated to reveal any defects. Magnetic flow or magnetising coil may also be used if flux path is extended using steel extension pieces.

4.4 Preparation

- 4.4.1 Specimens should be free from dirt, grease or scale, since these may hide defects and contaminate the magnetic ink. Scale may usually be removed by abrasive blasting or approved chemical methods and trichloroethylene or other suitable solvents are normally used for degreasing when the parts are being tested away from their assembled positions. Trichloroethylene should not be used for cleaning parts in situ, due to the health hazard. Unless otherwise specified, magnetic particle inspection should not be performed with coatings in place which could prevent the detection of surface breaking defects in the ferromagnetic substrate. Such coatings include paint or chrome plate thicker than 0.003", or ferromagnetic coatings such as electroplated nickel thicker than 0.001".

NOTE: The fluorescent properties of certain magnetic inks may be diminished by chemical reaction with acids. When acid pickling is used as a cleaning process, care is necessary to ensure that all traces of acid are washed off.

- 4.4.2 Preparation of the specimen should also include de-magnetisation. Magnetisation may have been induced by working, by machining in a magnetic chuck, or by lying adjacent to magnetised components or material. In the case of raw material, magnetisation may be removed by heating to a temperature above the Curie point for the material, but generally, for finished parts, it must be removed as detailed in paragraph 4.8.

- 4.4.3 Apertures such as oilways and deep tapered holes, which do not form part of the area to be examined, should be plugged to prevent the intrusion of ink, which may be difficult to remove.
- 4.5 **Magnetisation.** Components of simple shape will normally require magnetising in two directions, by a selection of the methods described in paragraph 3, so that defects of any orientation will be revealed. Components of complicated shape may require further magnetisation in selected areas to ensure complete coverage. A component should normally be demagnetised between each test, to remove the effects of residual magnetism, which could cause spurious indications.
- 4.6 **Inking.** Except where remanent magnetism is used to reveal defects (paragraph 3.1.3), magnetic ink should be applied gently, immediately before and during the period of magnetisation. With a.c. machines the magnetic flux should be applied for at least 3 seconds to allow time for the ink to build up at defects, but d.c. machines are often fitted with a time switch which limits the application of flux to between 1/2 and 1 second. When the immersion method is used, extreme care is necessary during removal of the specimen from the bath, in order to avoid disturbing the magnetic ink and any indications of defects which it may show.
- 4.7 **Interpretation of Indications**
- 4.7.1 Particles of magnetic ink are attracted to flux leakage fields and these may occur at defects, brazed joints, the heat affected zone in welds, or sudden changes of section. The presence of a sudden build-up of ink on a specimen is not therefore, necessarily an indication of a crack, inclusion or similar discontinuity and experience is essential in interpreting the indications produced by a test.
- 4.7.2 Cracks are revealed as sharply defined lines on the surface of the specimen, the magnetic particles often building up into a ridge which stands proud of the surface.
- 4.7.3 Subcutaneous defects such as may occur during manufacture of the material, will be more blurred than surface cracks. Non-metallic inclusions are often revealed by a diffuse clustering of magnetic particles, but may sometimes give an indication which is as sharply defined as a crack.
- 4.7.4 Grinding cracks are usually readily identified and consist of a pattern of irregular lines over the affected area, or, on small radius bends or teeth, they may appear as short parallel lines.
- 4.7.5 Tool marks may give an indication similar to cracks, but the bottom of a tool mark can usually be seen with the aid of a hand lens with approximately 5x magnification, whereas cracks are usually deep and narrow.
- 4.7.6 Localised magnetic flux resulting from ineffective demagnetisation, or careless handling after a specimen has been magnetised, may give indications known as magnetic writing. Careful demagnetising and retesting will show whether the magnetic writing is spurious, or an indication of a real defect.
- 4.7.7 Excessive magnetisation causes furring and magnetic particles tend to follow the grain flow, giving the appearance of clusters of inclusions. The remedy is to reduce magnetisation when testing areas of reduced cross-section.
- 4.7.8 Changes in permeability within a specimen, such as may occur at welds, may give misleading indications. Magnetic detection methods may not be suitable in these instances and radiography may have to be used.

4.8 Recording of Defects

- 4.8.1 Defects are normally marked with grease pencil or paint for future reference, but it may be necessary, for record purposes, to preserve the indications obtained in a test, either on the specimen or as a separate permanent record.
- 4.8.2 If the magnetic ink has an oil based carrier, the specimen should be drained and dried or, alternatively, another test may be carried out using an ink containing a volatile carrier fluid. If dry powder is used no preparation is necessary.
- 4.8.3 In cases where the specimen is to be retained, it should be gently sprayed with quick-drying lacquer or covered with a transparent adhesive film, care being taken not to disturb the surface indications.
- 4.8.4 If a separate permanent record is to be retained the specimen may be photographed, or one of the following actions taken:
- The indications may be covered with a transparent adhesive tape, which may then be peeled off and applied to a paper or card of suitably contrasting colour, to show the defects.
 - A strippable adhesive coating may be gently sprayed on to the surface of the specimen. When carefully removed, this coating will retain the indications of defects and these may be viewed on the surface which was in contact with the specimen.
 - The specimen may be heated and dipped in a thermosetting plastic powder material. When cured and stripped off, this material may be viewed as in b) above.

4.9 Demagnetisation

- 4.9.1 There are a number of reasons why specimens should be demagnetised before, during or after magnetic particle testing. These include the effects of magnetic writing (see paragraph 4.7.6), the difficulty which would be experienced in any subsequent machining operation due to the adherence of swarf, bearing wear due to the adherence of fine metallic particles and interference with the aircraft magnetic compasses. A specimen should, therefore, be demagnetised before starting tests, between tests which involve a change in flux direction and after tests have been completed.
- 4.9.2 The most commonly used demagnetiser is an aperture type of coil carrying an alternating current. The specimen should be placed inside the energised coil and withdrawn a distance of at least 1½ metres (5 feet) along the coil's axis with the current switched on, or may be placed inside the coil and the current gradually reduced to zero. Ideally, the coil should be just large enough to accept the specimen.
- 4.9.3 If a demagnetising coil is not available the crack detecting machine may be used. Alternating current from the machine may be passed through two or three turns of heavy cable, which may be used in the same way as a demagnetising coil. Alternatively, a suitably equipped direct current electromagnet machine may be used, the specimen being placed between the poles and the current being gradually reversed and reduced simultaneously to zero.
- 4.9.4 For demagnetising parts in situ an alternating current yoke is normally used. This consists of a coil wound on a laminated yoke, which is used in a stroking action on the specimen. The strokes should always be in the same direction along the specimen and the yoke should be moved away in a circle on the return stroke.
- 4.9.5 After demagnetising, the specimen should be removed from the vicinity of the demagnetising coil, the testing machine, or any other magnetised material.

4.10 **Tests for Demagnetisation of Parts**

- 4.10.1 Any components which are manufactured from steel and liable to affect the aircraft compass, should be demagnetised and a test for remanent magnetism carried out before assembly in the aircraft. The standard test for remanent magnetism in aircraft parts is the deflection of a magnetic compass needle under controlled conditions, but an alternative method, such as the use of a flux meter, may be permitted and suitable limits prescribed.
- 4.10.2 The test consists of placing a suitable magnetic compass in a position away from all stray magnetic influences and slowly rotating the component at a position along the east/west axis of the compass. The distance of the component from the compass should be specified for the test and should be the same as the distance from the aircraft compass to the installed component. Deflection of the compass needle by more than 1° will require the component to be demagnetised again and the test to be repeated.
- 4.11 **Final Cleaning.** When a component has been accepted following a magnetic detection test, all traces of detecting ink, contrast paint or temporary marking should be removed. Wiping or washing in solvent, or immersion in an approved degreasing agent are the methods normally used. During cleaning, any plugs or blanks fitted during the preparation for the test, should be removed. A temporary rust protective should be applied after cleaning and the part should be identified in accordance with the appropriate drawing, to indicate that magnetic flaw detection has been satisfactorily carried out.

5 **Technique Sheets**

- 5.1 A technique sheet is a document detailing all the magnetising operations to be performed when inspecting a particular component by the magnetic particle method. It may be accompanied by an illustration of the component and by instructions applicable to all magnetic particle tests, such as the methods of cleaning and demagnetising to be used.
- 5.2 A technique sheet should show all the relevant details for each magnetising operation, including type of equipment, strength and form of current, acceptance standard, contact areas, positions of flux detectors, type of coil, size of threading bar and test pattern, as appropriate to the particular test. It is recommended that the symbols used in BS 6072:1981 should be used on all technique sheets and, where appropriate, on related drawings or sketches.

INTENTIONALLY LEFT BLANK

Leaflet F-80 Eddy Current Methods

1 Introduction

- 1.1 This Leaflet provides guidance and advice on the eddy current equipment for detecting cracks, corrosion or heat damage in aircraft structures and also shows how the method can be used for the measurement of coating thickness or for sorting materials. Elementary theory of eddy currents is also included to show the variables which are being measured and to indicate the interpretation of results which may be necessary for a particular application. Nothing in this Leaflet should be taken as overriding the information supplied by aircraft or engine manufacturers.
- 1.2 Eddy current methods can detect a large number of physical or chemical changes in a material and the selection of the required parameter presents the equipment manufacturer with many problems; interpretation of the test indications would be very difficult if undesired parameters were not reduced or nullified. Conversely, equipment set up for a particular purpose is comparatively easy to use when indications are compared with a 'standard' or known defect. Eddy current equipment is normally built to perform only certain types of tests, these falling broadly into the categories of flaw detection, conductivity measurement and thickness measurement.
- 1.3 The main advantages of the use of eddy current methods are that they do not normally require extensive preparation of the surface or removal of the part to be tested, do not interfere with other work being carried out on the aircraft and with surface defects, offer improved sensitivity over other non-destructive techniques. Small portable sets are battery powered and can easily be used in comparatively inaccessible places in aircraft structures.
- 1.4 Eddy current testing may be subject to certain difficulties, including depth of penetration and the effects of surface coatings and unseen changes in the geometry of the material under test. In addition the results of a test can only be related to the size of signal received and are not necessarily an indication of the size of defect. Techniques are established after trials have shown a method which gives consistent results.
- 1.5 In aircraft work, eddy current testing is usually of the comparative type, a reference piece or standard in similar material containing an artificial defect, being used to compare indications from the part under test.

2 Principles of Operation

- 2.1 Eddy currents are induced in an electrically conducting material when the material is subjected to a changing magnetic field and normally flow parallel to the surface of the material (see Figure 1). In eddy current testing, a coil is supplied with alternating current and held in contact with (or in close proximity to) the test specimen. The alternating magnetic field produced around the coil induces an alternating eddy current in the specimen and the eddy current itself produces an alternating magnetic field which opposes and modifies the original coil field. The resultant magnetic field is the source of information which can be analysed to reveal the presence of flaws in the test specimen.

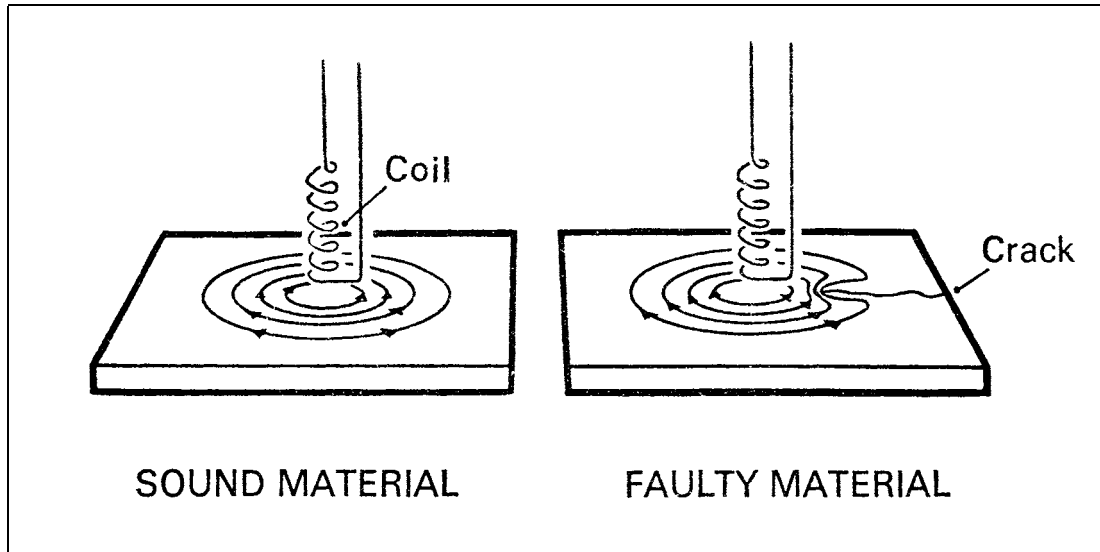

Figure 1 Eddy Current Flow

- 2.2 **Permeability.** This quality is a measure of the ease with which a material will conduct magnetic lines of force and decides the density of flux which can be induced in that material. Permeability is a function of magnetising force and flux density; air and non-magnetic materials have, for testing purposes, a permeability (μ) of 1, while ferromagnetic materials have a permeability greater than 1. Permeability is not constant in magnetic materials and varies with the magnetising force (coil current). Eddy currents are induced by flux changes in a material and are directly related to flux density; as permeability increases so the strength of eddy currents increases. Non-magnetic materials do not generate additional flux densities, but magnetic materials produce high flux densities which can mask all other measurements. During tests on ferromagnetic materials, that is materials with a permeability greater than 1, these effects can be suppressed or made constant by saturation with high d.c. or a.c. fields which, in effect, restore the permeability to 1.
- 2.3 **Conductivity.** Conductivity (σ) is a measure of the ability of electrons to flow through a material and is one of the main variables in eddy current testing. Each material has a unique value of conductivity and this fact enables changes in chemistry, heat treatment, hardness or homogeneity to be detected simply by comparing the conductivity with a specimen of known properties; increased conductivity gives increased eddy currents (although depth of penetration decreases). Conductivity is measured in either of two ways; it can be compared to a specific grade of high purity copper known as the International Annealed Copper Standard (IACS), which is considered as 100%, or it can be measured in metres per ohm millimetre². ($58 \text{ m}/\Omega \text{ mm}^2 = 100\% \text{ IACS}$).
- 2.4 **Effects of Specimen on Test Coil.** A probe coil placed on the surface of a specimen will possess a particular value of impedance which can be found by measuring the voltage across the coil. The voltages due to resistance and reactance can also be separated and if required, displayed on a cathode ray tube. Any change in conductivity, permeability or dimensions (d) of the specimen will, through the eddy current field, alter the coil's impedance, either in magnitude or phase and depending on the parameter sought, can be indicated on a meter or cathode ray tube display. Changes affecting apparent conductivity, e.g. a crack, will be 90° out of phase with changes affecting permeability or dimensions under certain test conditions.

- 2.5 **Geometry.** The size and shape of the test specimen may distort the primary magnetic field and mask defects in the affected area (see Figure 2). The effects of geometry can be overcome by probe design, equipment calibration, frequency selection, or the use of jigs to maintain the probe in a particular relationship to the material surface, but must often be taken into account when conducting tests.

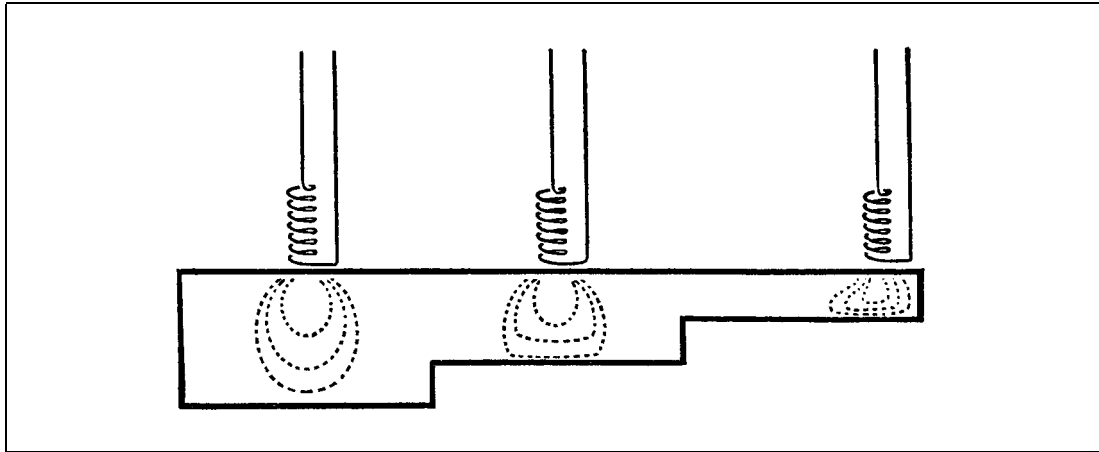

Figure 2 Geometric Effects on Primary Magnetic Field

- 2.6 **Penetration.** Eddy currents are strongest at the surface of a material and weaken with depth. This effect becomes more pronounced with increased frequency (f) of the alternating magnetic field and is known as 'skin effect'. Increases in permeability (μ) and conductivity (σ) in a material also decrease penetration depth. In practice the depth of penetration (P) of eddy currents is related to a depth where the current is reduced to $1/e$ (approximately 37%) of the surface current and may be calculated from the formula, $P \approx \frac{500}{\sqrt{f\sigma\mu}}$ where P is in mm and σ is in $m/\Omega \text{ mm}^2$.
- 2.7 **Effects of Frequency**
- 2.7.1 Any particular material possesses what is known as a characteristic frequency (f_g), which depends on its conductivity, permeability and dimensions. A practical use of the characteristic frequency is that samples of different materials tested at the same f/f_g ratio will give similar indications for similar defects. Actual test frequency is selected to obtain the best results from a particular test and depends on the type of defect sought, the depth of penetration required and the geometry of the specimen. When it is necessary to determine the phase of a signal, the frequency should be within the range where phase angle is greatest. When testing for conductivity only, to check hardness, heat treatment, etc., some penetration is required so a low frequency would be used, but when testing for surface cracks greater sensitivity would be obtained at a higher frequency.
- 2.7.2 In aircraft work testing is often concerned with thin sheet structure in aluminium alloy and test frequencies between 5 kHz and 4 MHz are used, depending on the defect sought. However, frequencies as low as 50 Hz are used for checking material properties in ferromagnetic materials.
- 2.8 **Lift-off.** This may be defined as the change in impedance of a coil when the coil is moved away from the surface of the specimen. This produces a large indication on the test equipment. In some equipment the lift-off effect is nullified by applying a compensating current to the probe circuit, thus enabling rapid testing without the need for special jigs, but in other equipment the lift-off effect is analysed to measure for example, the thickness of a non-conducting coating. This effect, when applied to encircling coils and bar specimens, is known as 'fill factor'.

3 Coil Arrangements

3.1 A number of different coil arrangements may be used in eddy current testing and some of the more common are discussed below. The types shown in Figures 3, 4 and 5 are not generally used during aircraft maintenance operations, but are widely used by material and component manufacturers.

3.2 **Single Primary Coil.** Figure 3 shows the simplest arrangement. If a sound specimen is placed in the coil the impedance of the coil is modified and if a faulty specimen is placed in the coil the impedance is modified to a different degree.

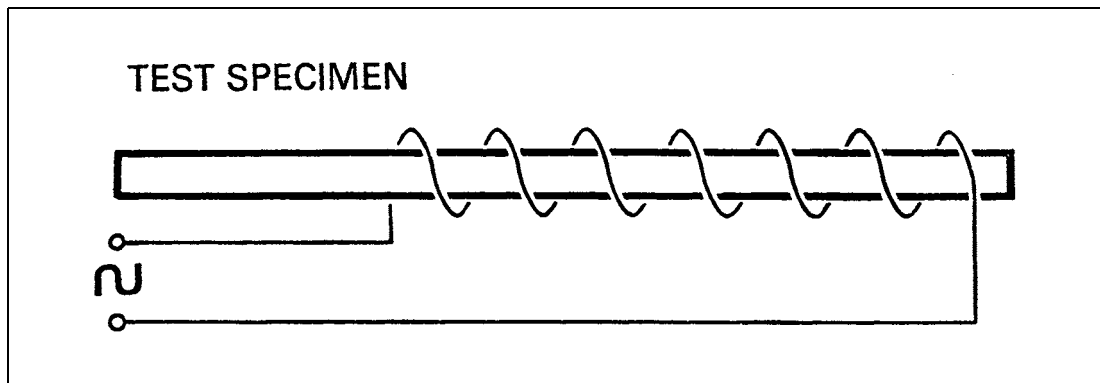

Figure 3 Single Primary Coil System

3.3 **Comparative Coil System.** Figure 4 shows a coil arrangement which has two arms, one containing a flawless reference piece and the other the test specimen. Since the two sets of coils are identical any fault in the test piece will result in a voltage across AB.

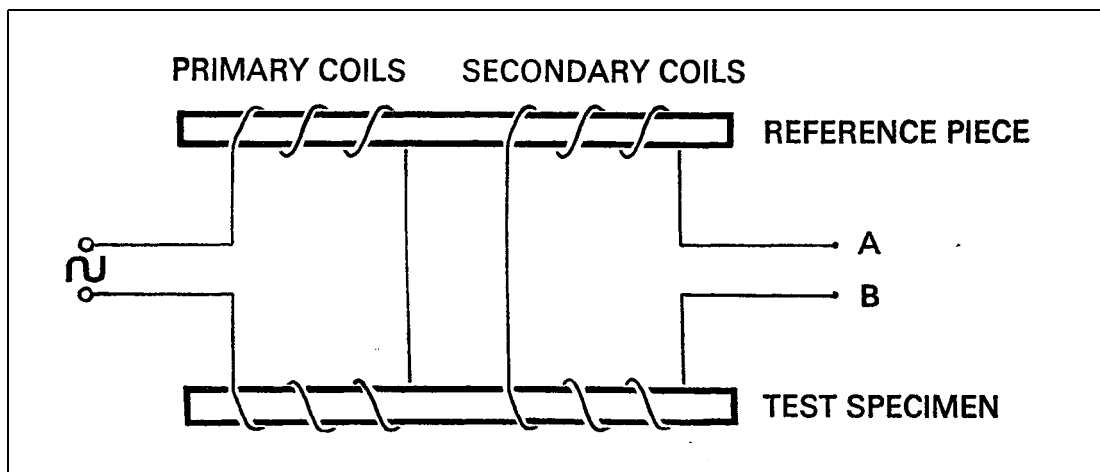

Figure 4 Comparative Coil System

3.4 **Differential Coil System.** Figure 5 shows a coil arrangement which is also a comparison method, but in this case adjacent portions of the test specimen are compared with each other. The coil windings are, in effect, identical to the comparative coil system shown in Figure 4.

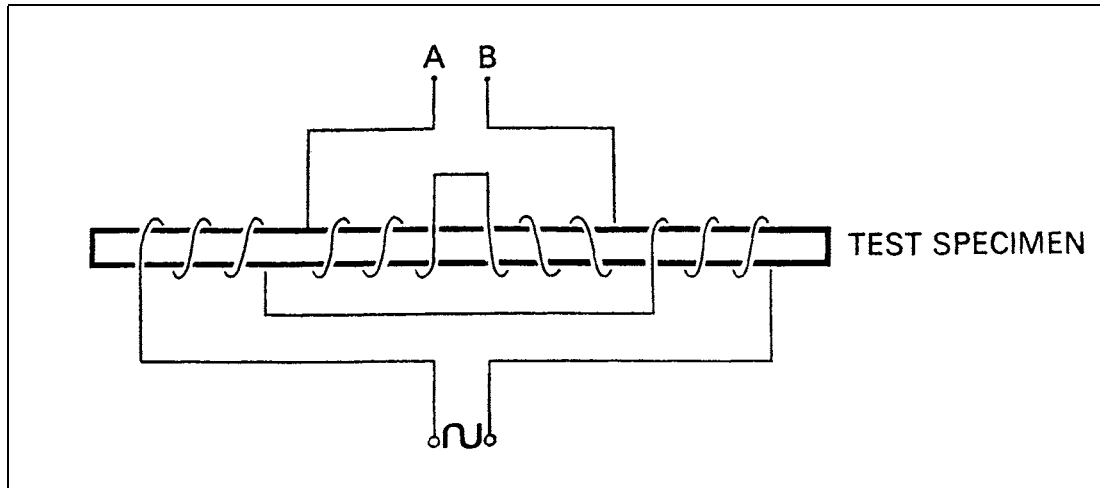

Figure 5 Differential Coil System

- 3.5 **Surface Coils.** In aircraft work a single coil is generally used, with the axis of the coil normal to the surface being tested (Figure 6). A ferrite core is used to increase sensitivity to small defects and the arrangement is used for detecting cracks in flat surfaces, curved surfaces or holes, by mounting the coil within a specially shaped probe. Impedance changes obtained during a test are compared with those obtained from a defective part or a reference piece.

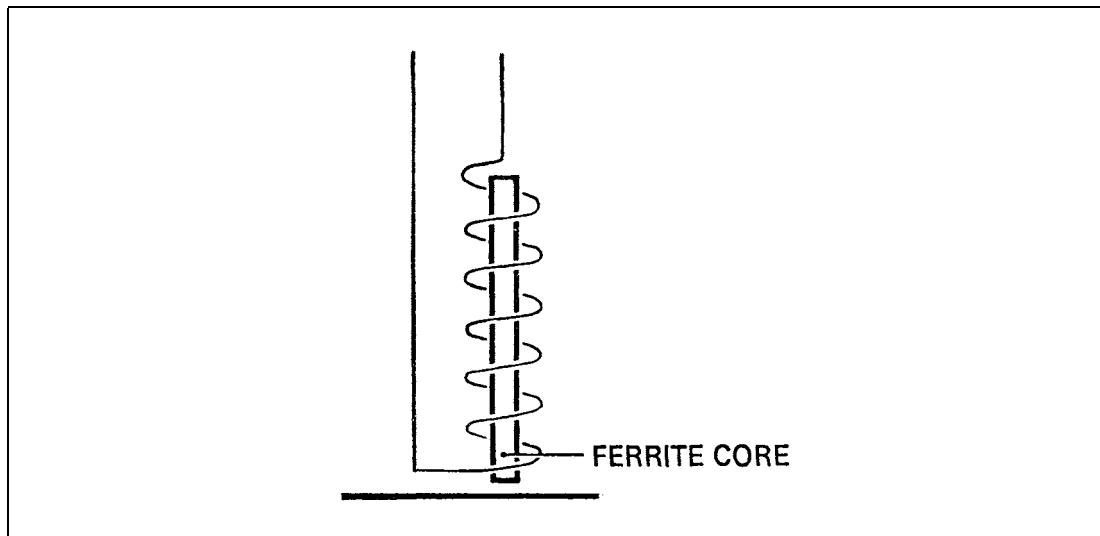

Figure 6 Surface Coil

4 Types of Circuits

- 4.1 **Bridge Circuits.** Figure 7 shows a bridge circuit, one arm of which consists of two adjustable controls and a coil and the other arm comprises the reference and test coils. The bridge is balanced initially (meter zeroed by adjustment of the variable resistor and inductor) with the probe located on a flawless specimen. In use, any alteration in the impedance of the probe coil (due to faults in the test piece, or to lift-off) will unbalance the bridge and result in a deflection of the meter needle.

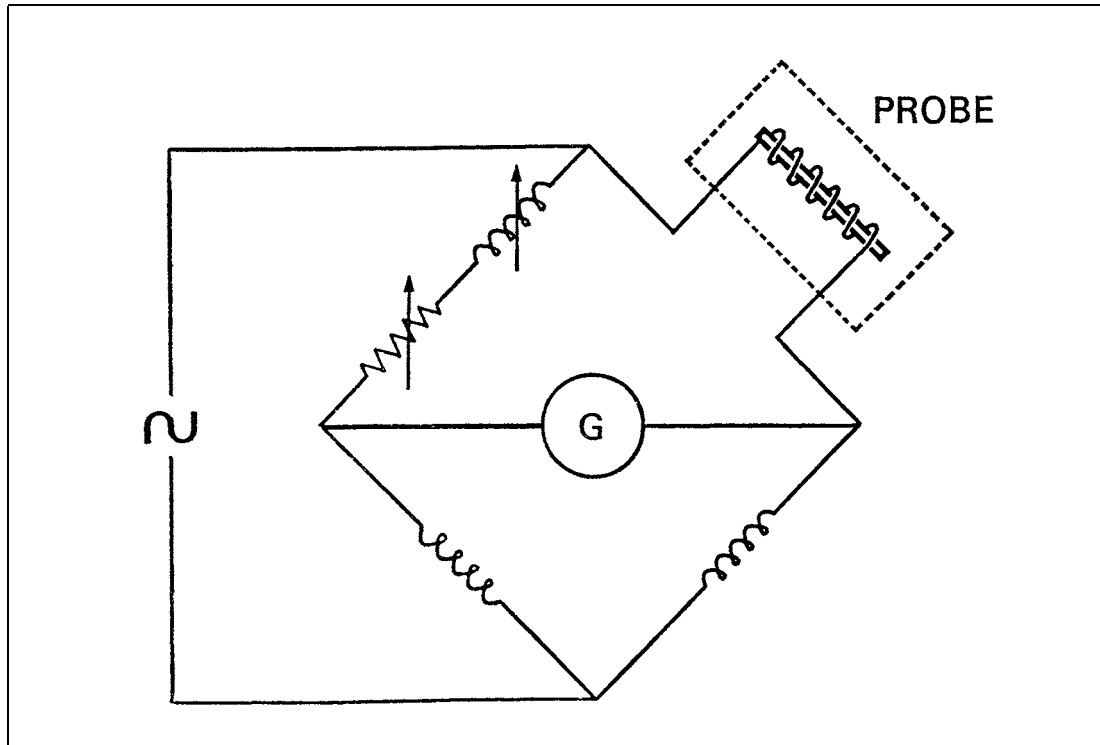

Figure 7 Bridge Circuit

4.2 Resonant Circuits

- 4.2.1 The capacitance of a coil is usually small in relation to its inductance. However, if a capacitor is connected in the same circuit as a coil, since inductive reactance increases with frequency and capacitive reactance decreases with frequency, a condition will occur, at some frequency, when the effects are equal and opposite. This condition is known as resonance and the circuit then behaves as if it contained only resistance, resulting in a large change in current flow.
- 4.2.2 Figure 8 shows a typical eddy current circuit which operates on the resonance principle. The probe is a parallel tuned circuit connected to the grid of an oscillator and determines the frequency at which the circuit oscillates. If the flux density (and hence the impedance) of the probe coil is altered (e.g. by placing the probe on a metallic object) the oscillator frequency changes. Consequently, the frequency developed in the anode tuned circuit is no longer the frequency at which that circuit is tuned. This results in a change of impedance, which is recorded on the meter through the secondary windings of the anode coil.
- 4.2.3 Operation of the circuit shown in Figure 8 is dependent upon adjustment of the controls to suppress lift-off. With the probe located on the test specimen the anode circuit is tuned to a frequency in sympathy with the probe circuit by adjustment of the variable capacitor (i.e. the lift-off control) until the meter reads zero. If the probe is now removed from the specimen a change in impedance will again occur and result in deflection of the meter needle; this deflection can be counteracted by adjustment of the set-zero and lift-off controls. Further adjustment of these two controls will enable a zero meter reading to be obtained with the probe on or off the specimen. Any change in the specimen (e.g. a defect) will result in a change in the impedance of the probe coil and a deflection of the meter needle, regardless of the presence of, for example, a paint film of uneven thickness.

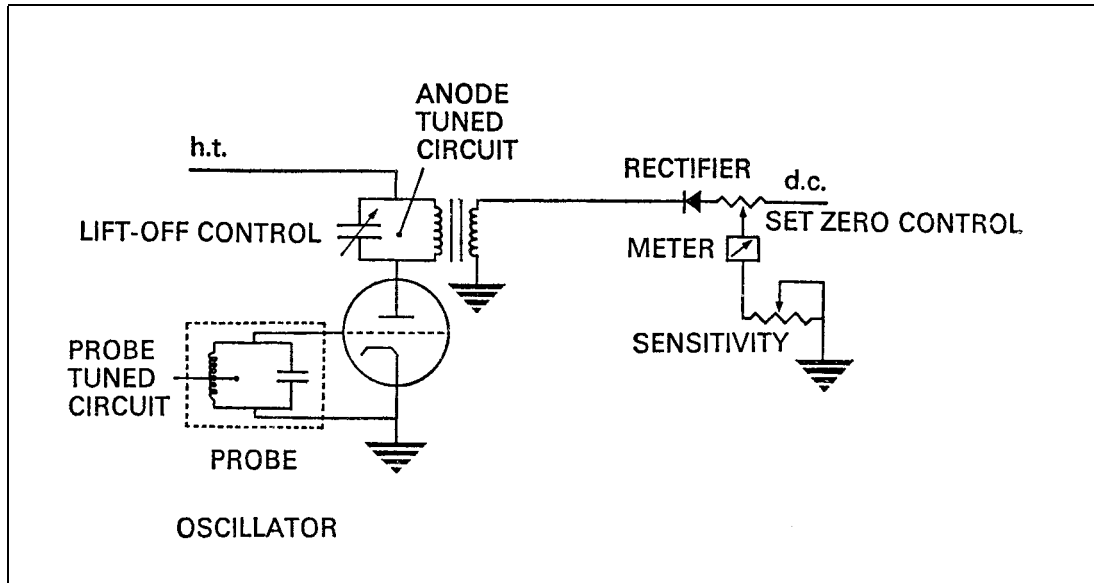

Figure 8 Typical Tuned Circuit

- 4.2.4 A different type of resonant circuit is shown in Figure 9. The probe coil and capacitor in this case being connected in series. Lift-off is suppressed by the addition of a compensating voltage to the measurement voltage.

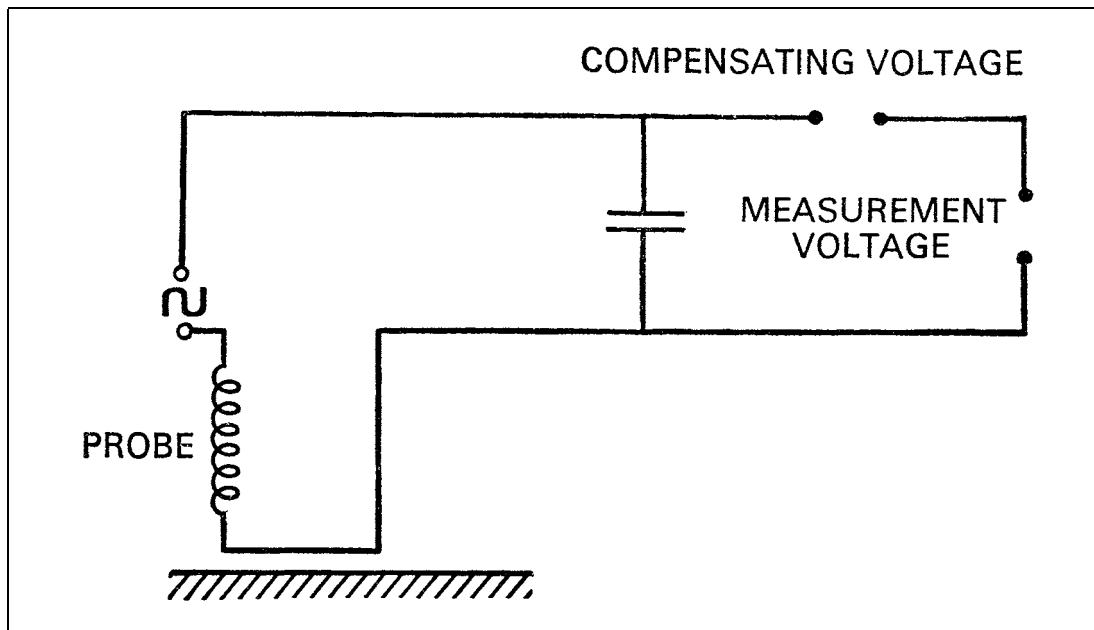

Figure 9 Series Resonant Circuit

5 Phase Analysis

- 5.1 Where one of the parameters affecting impedance is required and all others can be assumed to be constant, the measurement of total impedance changes will satisfactorily reveal the presence of a defect or change in the unknown parameter, provided that a suitable reference piece is used for comparison. However, in many cases it is necessary to separate the reactive and resistive components of impedance in order to detect a particular type of defect and more sophisticated equipment becomes necessary.

- 5.2 Figure 10 shows the oscilloscope trace of a signal containing two voltages, V_1 and V_2 , which are representative of the signal which could be obtained from eddy current equipment under certain test conditions. While the voltages are of the same frequency they can be seen to start at different points of the time scale, the difference resulting from the effects of reactance and being known as a phase change. Eddy current testing based on the use of phase changes is known as phase analysis.

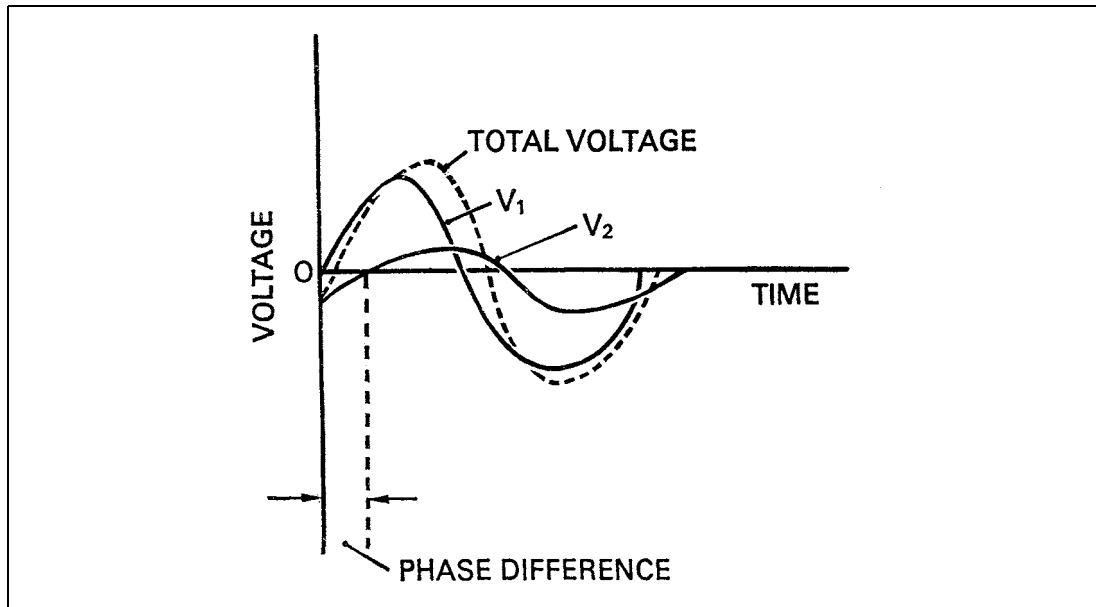

Figure 10 Phase Difference

- 5.3 One method of suppressing the unwanted components of the measurement voltage (i.e. probe coil voltage) and presenting only the parameter required, is to include a phase sensing device in the circuit. This operates on the principle that only those components which are in phase with a reference voltage are passed to the meter. Figure 11 shows a typical phase sensing circuit in which the measurement voltage is applied to one diagonal of a bridge and a reference voltage to the other. The rectifiers act as switches which pass current during one half of each cycle of the reference voltage only, but no reference current flows through the meter due to the symmetry of the bridge circuit. The measurement voltage is applied to the meter during those periods when the rectifiers are conducting and by varying the phase of the reference voltage, unwanted components of the measurement voltage can be eliminated.

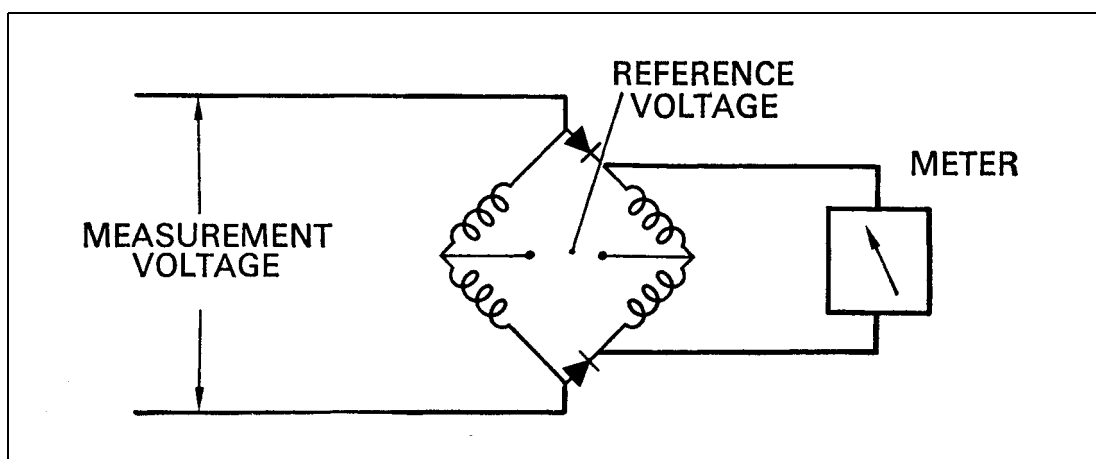

Figure 11 Phase-sensing Circuit

5.4 Displays

5.4.1 The resistive and reactive components of the measurement voltage (V_1 and V_2 respectively) can also be separated, fed to separate plates of a cathode ray tube (CRT) and presented as a two-dimensional display on the screen. By suitable phase controls the vertical and horizontal components can be made to represent, for example, conductivity variations and dimensional variations respectively. The most common types of display are the vector point, ellipse and linear time base.

5.4.2 **Vector Point.** A spot is projected on to the screen of the CRT, representing the end of the impedance vector (Z) (Figure 12) and is adjusted to the centre of the screen when the test piece has the same properties as the reference specimen. Any anomaly in the test piece will result in movement of the spot, the direction of movement being an indication of the cause of the anomaly. If more than one variable is present, since the position of the spot indicates direction and magnitude, the cause can often be determined by vector analysis.

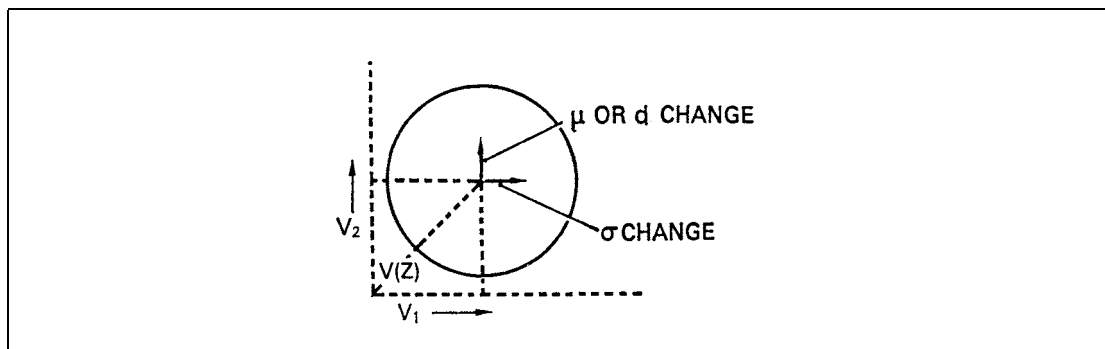

Figure 12 Vector Point

5.4.3 **Ellipse Method.** A comparative coil arrangement is also used in this method. In the balanced condition a horizontal line is shown on the screen of the CRT whilst an unbalanced condition can be shown in either of two ways. One variable can be displayed by a change in the angle of the line and a second variable by the formation of an ellipse (Figure 13). By analysing the position and shape of the ellipse both variables can be evaluated.

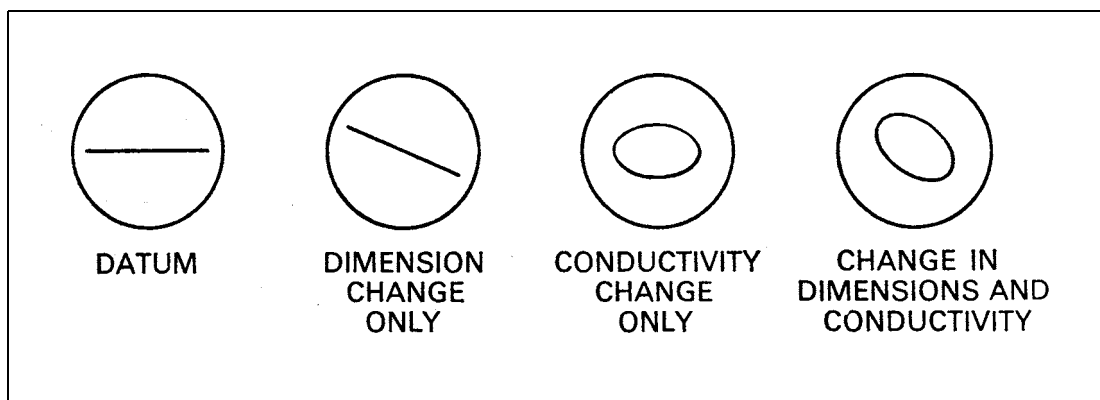

Figure 13 Ellipse Method

5.4.4 **Linear Time Base.** A spot moving across the screen at a constant rate can be adjusted to show the wave-form of the voltage from a comparative coil system. A change in impedance will alter the wave-form and either of the components of impedance can be measured by adjustment of the phase shift controls. To assist in measuring any changes, the screen is often fitted with a slotted cursor (Figure 14).

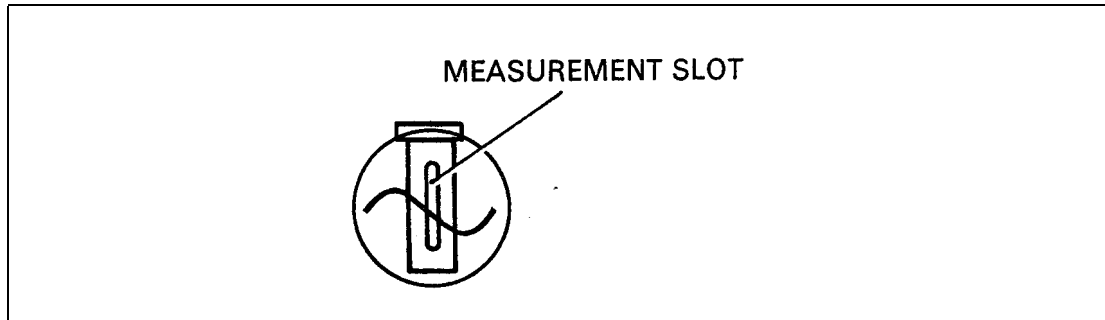

Figure 14 Linear Time Base

6 Probes

6.1 Unlike ultrasonic probes, the probes used in eddy current testing, because they are connected to the material by a magnetic field, do not require a coupling fluid and no surface preparation is necessary other than the removal of any surface condition which would hinder free movement of the probe. Coils are also normally wound on a ferrite core and this has the effect of concentrating the magnetic field and increasing sensitivity to small defects. Coils are often protected by enclosures in a plastics case, but the ferrite core is often left unprotected when required by particular test conditions. To maintain the coils in close proximity to the work it is often necessary to design a probe for one particular use only; some of the probes commonly used in aircraft work are discussed in 6.2, 6.3 and 6.4.

6.2 **Surface Probes.** Figure 15 shows two typical surface probes. (A) could be used for detecting surface cracks and would be connected to a resonant circuit type of test set, whereas (B) could be used for coating thickness measurement or conductivity tests and would be connected in a bridge circuit type of test set. In the case of (A) a simple jig may be necessary to prevent spurious indications due to inadvertent probe angulation.

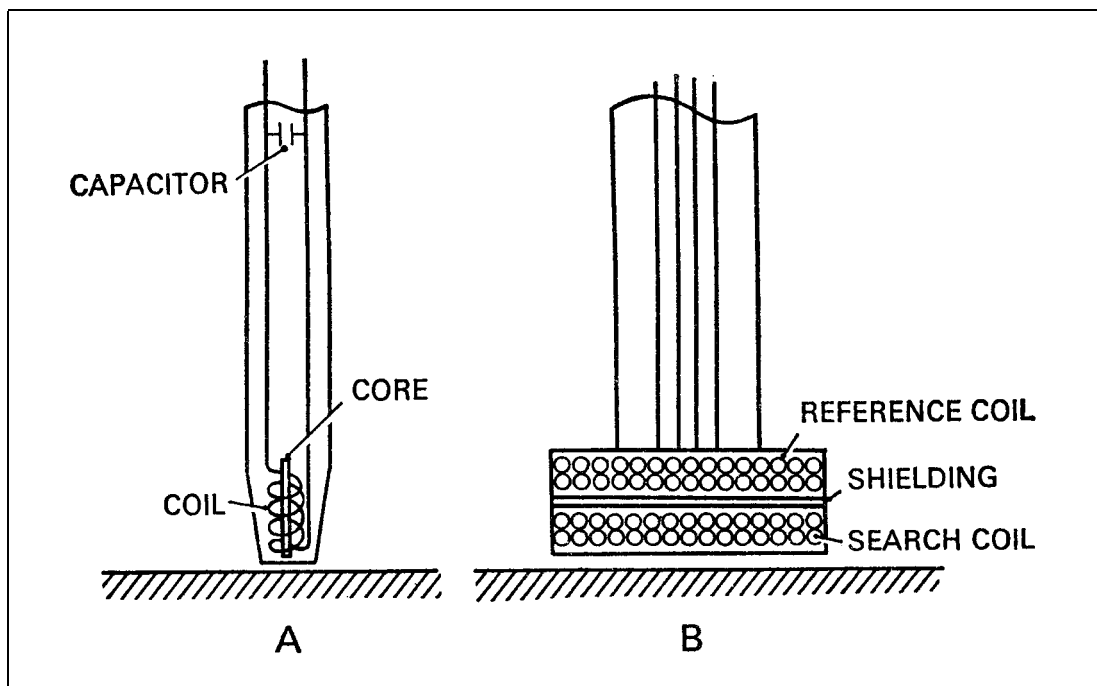

Figure 15 Surface Probes

6.3 Hole Probes

- 6.3.1 Hole probes used during material manufacture would normally consist of a coil, the axis of which would be coincident with the axis of the tube under test, but in aircraft work a hole probe is normally located with the coil diametrically across the hole to achieve greater sensitivity. This type of probe is therefore a surface probe used for testing the surface of a hole. Figure 16 shows a typical hole probe of the latter type, the main use for which would be the detection of radial cracks round fastener holes.

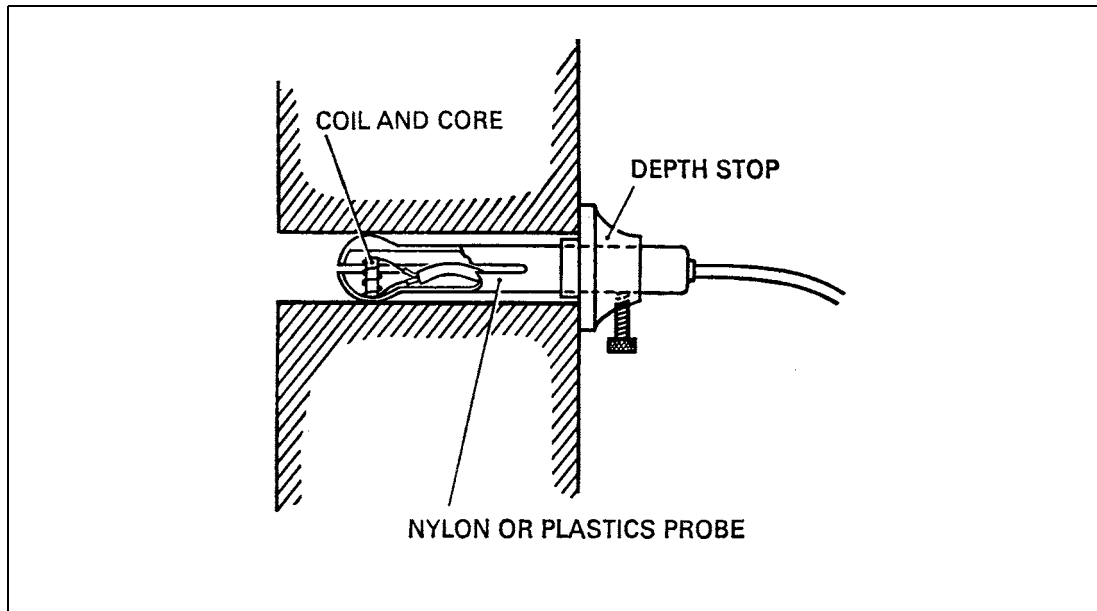

Figure 16 Hole Probe

- 6.3.2 The actual position of a crack can be determined by using an offset coil as illustrated, or by shielding one end of the coil.
- 6.4 **Special Probes.** Probes may be designed to suit any application, the object being to present a coil at a particular position on a component, so that information can be obtained from changes in the coil's impedance. Examples of the use of special probes would be for the detection of cracks in wheel bead seats, turbine engine compressor or turbine blades and each of these probes could be connected to a single test set of suitable frequency and complexity. Probes are also designed with a view to eliminating the need for disassembly when carrying out routine maintenance operations.

7 Reference Pieces

- 7.1 In order to calibrate the equipment, standard reference pieces, manufactured from a material similar to that being tested, are necessary. These pieces should contain defects of known size and shape, so that the change in coil impedance against a known defect could be used as an acceptance limit.
- 7.2 A typical reference piece for surface crack tests would contain, for example, three cuts of different depths, the depth being marked adjacent to each cut and the block being marked with the material specification. The test acceptance level could then be related to a signal of the same amplitude as that obtained on a specified cut in the block.

- 7.3 Reference pieces are usually small in size and can be taken to the test location so that quick cross-reference can be made between the reference piece and the test specimen.

NOTE: Since the manufacture of a reference piece involves the removal of metal (by saw cut or spark erosion), the phase and magnitude of the impedance changes will not be identical with those obtained from a natural crack of similar depth. For this reason, actual defective aircraft components are sometimes used to give comparative readings.

8 Typical Applications of Eddy Currents

- 8.1 The eddy current equipment used in many material manufacturing processes is very sophisticated and completely automatic. Bar, tube and wire materials are normally passed through encircling coils of suitable size and defects are both displayed on a cathode ray tube and recorded by tape or memory store. Audible warning, marking and defective component rejection systems, actuated by the defect signal, are also often included. A recent innovation is the use of rotating probes through which bar material can be passed, the advantage of this method being an increase in the sensitivity to surface cracks. In aircraft maintenance work, however, eddy current equipment is usually restricted to conductivity tests and crack detection, mainly by the use of surface probes. Sophisticated equipment such as that described above is not normally required and equipment is usually portable and battery operated. The following paragraphs describe typical eddy current applications.

8.2 Checking Fastener Holes for Cracks

- 8.2.1 A suitable equipment for testing holes would be a simple impedance test set (i.e. not including phase analysing circuits) with lift-off control and the probe would be similar to that shown in Figure 16, adjusted to be a snug fit in the hole. The reference piece should be of similar material to that being tested and should contain holes of the same size as the probe with natural cracks or artificial notches at various depths in the hole to simulate cracks of maximum acceptable size.

- 8.2.2 The following procedure should be used when carrying out a test:

- a) Clean loose paint, dirt, burrs, etc. from inside and around the holes being checked.
- b) Calibrate instrument and adjust for lift-off in accordance with the manufacturer's instructions.
- c) Insert probe in hole in reference piece and adjust depth stop to obtain maximum needle deflection from a selected notch or crack. Adjust sensitivity to give the specified scale deflection from the crack.
- d) Insert probe in hole in test specimen and slowly rotate, noting and marking any holes producing needle deflections greater than that from the reference piece. Re-check probe in reference piece frequently.

NOTE: Any ovality in hole diameter will give a meter deflection which can be confused with the signal from a crack. Generally the indication from ovality shows a much slower change than that from a crack as the probe is rotated.

- e) Repeat c) and d) at incremental depths to cover the hole surface completely.
- f) Ream out marked holes as recommended by aircraft manufacturer and repeat test with an appropriate sized probe and reference piece hole.

8.3 **Checking Heat Damaged Skin**

- 8.3.1 The conductivity of aluminium alloy sheet will increase with exposure to elevated temperatures up to approximately 500°C and above this temperature obvious signs of damage such as melted or charred metal become apparent. Tests conducted on the surrounding material will show the extent of the area in which the metal is below strength requirements and must be replaced.
- 8.3.2 The acceptable range of conductivity readings depends on the type of material and its heat treatment condition and these readings may be stipulated in the appropriate Maintenance Manual. As a rough guide, the conductivity of unclad 7075-T6 material is 31% to 35% IACS, but the important reading in relation to heat damage is the change in conductivity between sound and defective material.
- 8.3.3 A conductivity meter should be used for this test and this will normally be an impedance change instrument, with a meter and separate scale graduated in percentage IACS. This equipment is supplied with a surface probe and two test samples, one of high purity copper (with high conductivity) and the other a material of low conductivity, for calibration purposes.
- 8.3.4 The following procedure should be followed when carrying out the test:
- Thoroughly clean area to be inspected.
 - Calibrate instrument in accordance with the manufacturer's instructions.
 - Place probe on sound skin of similar material and thickness and remote from the heat affected zone and adjust scale until meter is zeroed. Compare this reading with the expected conductivity.
 - Check conductivity all round the affected area, noting any meter deflection and marking the skin accordingly. By this means a demarcation line can be drawn round the damaged area and material removed up to this line.

8.4 **Detection of Corrosion**

- 8.4.1 Corrosion on hidden surfaces can be detected by eddy current methods using phase sensitive equipment. If a reading at the normal thickness of a sheet material can be taken, since corrosion reduces the thickness of a sheet, when the probe is over a corroded area a different reading will be obtained. The equipment can be set up by noting the readings obtained from a sound material of, say, 90% of the thickness of the test specimen and a rough estimation of the volume of corrosion beneath the probe can be obtained during a test.
- 8.4.2 Equipment is available which is specially designed for thickness measurement having a meter graduated in appropriate units, but any equipment operating at a frequency which would give a penetration depth at least equal to the sheet thickness could be used to give an indication of the presence of corrosion. Equipment designed for detecting surface cracks and operating at very high frequency would be unsuitable.
- 8.4.3 Care is necessary when checking for corrosion to ensure that underlying structure (stringers, frames, etc.), chemically contoured areas and loose debris, do not cause misinterpretation of results.
- 8.5 **Material Sorting.** Provided that a known sample is available, eddy current equipment can be used to ensure that a batch of materials is correctly identified, or that a component is made from the correct material. Simple impedance equipment could be used for coarse sorting, but in order to differentiate between materials closely related in composition, equipment with phase sensing circuits is necessary. By placing the known sample in an encircling coil the characteristic trace of that

material can be displayed on an oscilloscope and unknown samples accepted or rejected by comparison.

- 8.6 **Coating Thickness Measurement.** The thickness of conducting or non-conducting coatings on ferrous or non-ferrous bases can be measured using basic eddy current methods; although measurement becomes difficult where the conductivity of the coating and base metal are similar. It is possible to utilise crack detection equipment for measuring thick coatings, by comparing the readings obtained from the test specimen with the lift-off effect obtained when the probe is placed on slips of non-conducting material (e.g. mica) of known thickness. When measuring very thin coatings however (i.e. less than 0.12 mm (0.005 inch)), it is recommended that equipment designed specially for coating thickness measurement should be used.

9 Reference Material

- 9.1 Further information on eddy current theory and operating principles may be obtained from the following publications:

Standards

BS 3683	Terms Used in Non-destructive Testing. Part 5, Eddy Current Flaw Detection.
BS 3889	Methods for Non-destructive Testing of Pipes and Tubes. Part 2A, Eddy Current Testing of Ferrous Pipes and Tubes. Part 2B, Eddy Current Testing of Non-ferrous Tubes.

Text Books

Non-destructive Testing Handbook Vol.II, 1963, by Robert C. McMaster.
(The Ronald Press Co.)

Non-destructive Testing, 1968, by William E. Schall.
(Machinery Publishers Ltd. London)

Non-destructive Testing No. CT-6-5, 1967,
(General Dynamics, Convair Division)

Electromagnetic Testing Handbook H54, 1965,
(Office of Assistant Secretary of Defense, Washington.)

Leaflet F-90 Endoscope Inspections

1 Introduction

- 1.1 This Leaflet provides guidance and advice on the use of endoscope inspection equipment (also known as boroscope, introscope or fibrescope equipment, depending on the type and the manufacturer) for the assessment of engine serviceability, both on a routine basis and for the investigation of developed defects. Although endoscope inspections are utilised in other areas, the information in this Leaflet is intended primarily for the inspection of gas turbine engines; it is not related to any particular engine and should, therefore, be read in conjunction with the relevant Maintenance Manuals and approved Maintenance Schedules, which should also be consulted for specific damage and time limits.
- 1.2 Endoscope equipment permits the inspection of gas turbine engine parts which would otherwise be inaccessible with the engine installed and in service. Early gas turbine engines had poor provision of ports for this type of inspection, apart from the igniter plug and burner holes, but engine manufacturers now tend to provide improved facilities for endoscope inspection of the rotating and combustion sections of the engine. Other large engine components may also have limited facilities, as do some airframe air-conditioning turbine units, etc.
- 1.3 Engineers should be conversant with the techniques of endoscope inspection to enable them to use the equipment as an effective inspection and diagnostic tool and as part of normal inspection procedures. This form of use will result in a more effective assessment being made of damage caused by an in-service incident such as a bird strike or foreign object ingestion.

2 Endoscope Equipment

2.1 Manufacturers of endoscopes tend to market the complete range of units required and it is unusual to be able to interchange parts of one system with those of another. The following general description of the equipment is not related to any particular manufacturer and should be read in conjunction with the appropriate manufacturer's technical instructions or service manual.

2.2 The Probe

2.2.1 The probe is an optical instrument which performs two functions:

- a) it relays and directs a beam of light for illumination and
- b) it displays a focused and undistorted image at the eye-piece.

Probes differ in that some have an integral light source, while others rely on a remote 'light box'; another version has a small bulb at the tip of the probe to provide the illumination. In addition, facilities for adjusting the focus and magnification may be incorporated.

2.2.2 The probe shaft usually consists of concentric tubes, the inner one of which is the view tube, while the outer one provides a separate light path for the illumination beam. This beam is carried through an annular 'fibre optic bundle' to the tip where the necessary change in direction is made through prisms. The image is modified throughout its travel through the view tube by a series of lenses and may also be changed in direction by the same method.

- 2.2.3 At the tip, the prisms are protected by windows which prevent dust, grit or direct contact harming the optical clarity of the image. If the probe is of the non-adjustable type, the angle of view at the tip will be marked and there are the following four variations:
- a) Straight View, where the centre of the field of view is parallel to the probe shaft.
 - b) Lateral View, where the centre of the field of view is at right-angles to the probe shaft.
 - c) Oblique View, where the centre of the field of view is at an oblique angle to the probe shaft.
 - d) Retro View, where the centre of the field of view is at an acute angle to the probe shaft, resulting in an amount of doubled-back view.
- 2.2.4 The field of view is designed to give a fairly useful amount of visible area and magnification at the kind of distances required in the internal inspection of a gas turbine engine. The eye-piece makes the final adjustment to the image before visual perception and provision is usually made here to indicate the relative direction of view with respect to the engineer. An array of inscribed lines, called a graticule, is sometimes provided to indicate, under specific conditions of use, a measurement of distance useful for damage assessment. Accessories can enable a still camera to be used to provide a permanent record of defects, etc. and television and video equipment can be used for applications where direct access to the probe would be uncomfortable or unsafe.
- 2.2.5 Flexible endoscopes (Figure 1) rely on fibre optic bundles to transmit an image in the same way as the illumination beam is transmitted along the rigid probes. However, for the transmission of an image, the relationship of each fibre to all of its neighbours must be the same at the eye-piece as at the probe tip. The image bundle and the illumination bundle are concentric with each other, with the image bundle forming the central core. The flexible probe tips are usually changeable and are of less elaborate manufacture, allowing the tip to be shorter, thus not having a cumbersome non-flexible end to restrict use in a confined space.
- 2.2.6 Migration of fluids by capillary action along the bundles between the individual fibres is prevented by the application of a transparent resin to the bundle ends. Compression, twisting and kinking of the fibre optic bundles is prevented by fitting the bundles in a flexible conduit, normally of spiral or 'armadillo' manufacture, which will restrict the manipulation of the probe to within the capabilities of the bundles.
- 2.3 **The Light Source.** Most endoscope equipment now in use utilises a separate and remote light source to illuminate the view area. This normally takes the form of a self-contained 'light box' containing the lamps, transformers, switchgear and cooling fans to provide a high-intensity beam. This beam is focused upon an adaptor in the box to which the fibre optic light bundle from the probe is connected. Quartz/halogen or quartz/iodine lamps provide the source of light, which may be varied in intensity to suit both the application and personal preference. Mains power supplies are normally used although some equipment can be arranged to allow typical aircraft voltages and frequencies to provide the system with power.

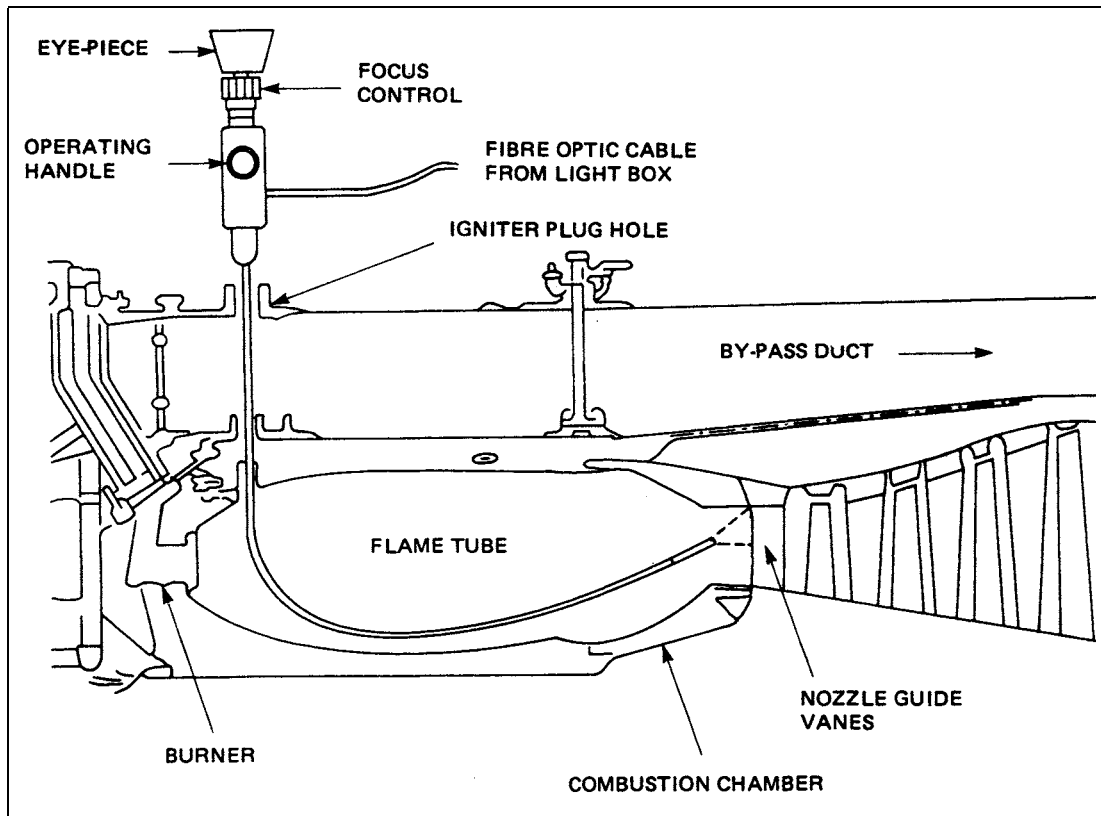

Figure 1 Flexible Endoscope Inspection Equipment

3 Preparations

- 3.1 **Precautions.** Consideration must be given to the potential hazards involved in the inspection of gas turbine engines while under ramp or first-line maintenance conditions and special precautions should be taken because of the engineer's pre-occupation at the engine. A dangerous situation could occur in the event of the inadvertent operation of a starting system, ignition system, thrust reverser system or any mechanical or electrical controls; these systems should therefore be inhibited.
- 3.2 Other factors to be considered when inspecting engines under these conditions include:
- Dissipation of residual heat;
 - Effect of windmilling;
 - Endoscope equipment contamination;
 - Electrical potential difference between the probe/light source and the aircraft structure;
 - Fuel and oil leakage.
- 3.3 **Access**
- 3.3.1 Engines designed for endoscope inspections have access ports fitted with blanking plugs at various points in the casings and the areas visible through these parts are detailed in the relevant Maintenance Manual. However, if specific access is not provided, a general knowledge of the layout of the engine together with the access provided by the removal of igniter plugs, temperature probes, pressure sensing lines,

compressor bleed valves and other air off-takes enables useful condition assessments to be made. Forward view endoscopes can also be used to view through the air intake of an axial flow compressor or, to a more limited degree, through the turbine, the latter being restricted because of the greater curvature of nozzle guide vanes.

3.3.2 Access-port blanking plugs are subject to high temperatures and high rates of temperature change. This has the effect over a period of time of 'pinching' the blanking plugs to a higher torque than was applied at assembly. During removal, therefore, care must be taken to select a spanner which is a good fit on the plug and which will provide adequate leverage. Plugs which are fitted into blind holes in engine casings invariably have thread inserts and these, under high torque removal stresses, can become extracted with the plug and will require replacement.

3.3.3 The 'pinching' effect can be overcome to a certain extent by applying an anti-seize compound when fitting the blanking plugs. Manufacturers usually recommend the application of a graphite-based release agent which forms a dry film on the threads. Alternatively, a paste with metal or metal oxide content is applied. Neither paste nor dry film should be applied unless it can be established which of the compounds had been used previously, as any mixing will result in the formation of a hard-setting compound.

NOTE: In consideration of this 'pinching' effect, the initial torque settings for the blanking plugs must be those recommended in the relevant Maintenance Manual.

3.4 **Orientation.** Familiarity with the layout of an engine and experience in the use of endoscope equipment enables an engineer to recognise the area being viewed and the extent of inspection possible through a given access port.

NOTE: Parts frequently appear larger when viewed through an endoscope and damage can seem more extensive than it really is. Familiarisation with the size (height and width) of the item being viewed is therefore essential and ideally a spare part should be available to be held in the hand and viewed with and without an endoscope probe to ensure the item is correctly assessed.

3.5 Non-rotating assemblies cause few problems because major components such as burners and stators provide points of reference. Damage reporting on non-rotating components requires that burners, flame tubes, etc., be numbered to a standard form and that areas and components are named. An inspection report can then identify areas of damage by stating:

- a) Access port used;
- b) Direction of view;
- c) Area or component inspected (by name and/or number);
- d) Dimensions of and type of damage.

3.6 Components of rotating assemblies need to be identified for the same reasons. At overhaul, marks may be applied to the convex surface of turbine blades, together with the balance details normally applied, to number the blades consecutively around the disc. This procedure will enable positions to be fixed for the parts of the whole spool connected to that turbine. For instance, if HP turbine blades are numbered, HP compressor blades can be identified by stating:

- a) Compressor access port used;
- b) Direction of view;
- c) Details of damage;

- d) Turbine access port used;
 - e) The turbine blade number visible at the centre of the field of view.
- 3.7 The number of blades in a particular compressor or turbine stage should be known and the blades counted while viewing to ensure that all blades in the stage are checked. When viewing large blades, such as early compressor stages, it will be necessary to make two or three passes to cover the complete blade length, i.e. view the outer third of the aerofoil, mid span section and inner third adjacent to the inner platform.
- 3.8 **Inspection**
- 3.8.1 If damage is found on a rotating assembly which has no consecutive numbering of blades, point reference must be established by using an externally or internally recognisable point on the rotating assembly. Again, access ports must be stated and consecutive blades must be counted to locate the point of damage.
- 3.8.2 For ease of inspection, the HP shaft can be rotated (at a suitable speed to permit a satisfactory inspection) by an air-driven motor through the high-speed gearbox on engines with a drive facility; otherwise, hand-turning may be accomplished by using either a redundant component drive coupling or a standard socket fitting in the gearbox. Air-driven motor systems in general use have hand or foot controls to vary direction and speed; this is an advantage over using the hand-turning method which requires one person to turn the shaft while another performs the inspection.
- 3.8.3 LP shafts must be turned by hand and to rotate an Intermediate Pressure shaft in a three-spool engine, without a gearbox, a locally-made tool may be required to turn the shaft through the IP intake.

4 Inspections

- 4.1 One of the reasons for the increased use of endoscopes is the high cost involved in engine changes, either due to suspected internal damage or because of a Maintenance Schedule based on a "Hard Time Life" philosophy. It is therefore, an advantage to allow the engines to remain in service until defects are revealed via performance analysis, oil analysis, endoscope inspection, or by repetitive monitoring of allowable damage.
- 4.2 **Scheduled Inspections.** Scheduled inspections are the regular ones which are carried out as part of an approved Maintenance Schedule. The frequency of such inspections is dependent upon either engine cycles or flight time and need not be concurrent with the aircraft's scheduled checks. The combustion section and the turbine blades are the primary concern during these inspections, due to the high stresses and temperatures encountered during service. All defects should be recorded, normally on a chart specific to the engine type, which after completion constitutes a record of any deterioration taking place within that particular engine. An assessment can then be made as to whether the engine may be allowed to continue in service until the next scheduled inspection, or that it may only continue in service subject to more frequent checks.
- 4.3 **Special Inspections.** Occasionally, experience gained by frequent endoscope inspections, in-service failures or inspection during overhaul highlights the development of particular defects which can be monitored using endoscopes while the engine continues in service. Normally only one or two access ports need be disturbed because it is only the area detailed by the special inspection which needs

assessing. This again enables the engine either to continue in service or to be monitored even more frequently.

NOTE: Engines are often removed after scheduled or special inspections to prevent a primarily minor defect causing secondary damage, possibly leading to engine failure.

4.4 **Non-scheduled Inspections.** Endoscopes can be used to great effect when it is necessary to assess the damage caused by foreign object ingestion or engine surge, diagnose the cause of developed defects and provide a means of establishing engine serviceability following excursions beyond the normal turbine temperatures or maximum power limits. Together with other basic visual techniques of inspection, the use of endoscopes may, under certain circumstances, provide the necessary evidence to permit an aircraft to fly back to base for repair when it would otherwise require an immediate engine change.

4.5 **Final Inspection.** On completion of an endoscope inspection, it is essential that all access plugs are refitted correctly and securely. Failure to do so could cause a gas leak and result in a fire warning, shut-down and turn-back or in some cases cause a failure due to blade flutter or loss of cooling air. Access panels must also be correctly refitted.

5 Application

5.1 Components normally inspected with an endoscope, such as compressors, combustion sections and turbines, are subject to different types of damage and defects; therefore, actual limits and the specific forms of defects can only be found in the relevant Maintenance Manual.

5.2 Compressors

5.2.1 Endoscope inspections after such occurrences as foreign object damage (FOD), bird strikes or surge, must be systematic, not confined to single stages and always preceded by a comprehensive external visual examination. In addition to the endoscope ports provided, it may be possible to use bleed valve apertures and air-sensing probe points to inspect the compressor.

5.2.2 The most common form of damage to compressors is FOD. Centrifugal compressors have proved to be fairly damage-resistant but axial compressors are not so resistant to FOD and are also subject to surge damage. Inspection of axial compressors and their blades should, therefore, always include a search for evidence of FOD in all its manifestations - nicks, dents, scratches and the cracks which these defects may produce.

5.2.3 Surge damage may be in the form of trailing edge cracks at the blade root, rubbing marks on the blade platform or blade shroud, with perhaps damage to the spacer plates between the blades. Interference between tips or shrouds and the casing can occur during surge and may bend blade tips, cause cracks, etc. Interference between rotors and stators (clanging) is a more serious defect because of the likelihood of substantial deformation. Engine manufacturers normally know the type of damage which may be caused to their engines during surge and the Maintenance Manual may, therefore, indicate which particular stage or stages need to be inspected and which defects are particularly indicative of surge damage.

5.2.4 Grime and oil deposits may form on the compressor blades over a period of time. Excessive oil deposits are usually an indication of front bearing oil leakage or general wear in the engine. Where engines are operated in sandy conditions, dust tends to stick on the rear of the compressor if there are oil deposits present and such engines could benefit from compressor washing procedures.

5.2.5 Compressor blades which have mid-span shrouds (or clappered blades) are sometimes subject to wear at the point where the end of each shroud abuts its neighbour. On 1st stage LP or fan blades this wear is recognised and can be measured by taking up the total free play of the whole stage, by moving half the blades clockwise about their mounting pins and the other half anti-clockwise; this leaves a gap between one pair of blades which represents total shroud wear. Of course, this procedure will not be suitable for other than fans or 1st and maybe 2nd, stage LP blades. Inspection of mid-span shroud wear through an endoscope is confined to a close and clear view of abutting shrouds. Shrouds which are wearing may be recognised by:

- a) Metallic streaking from the join;
- b) A wavy, uneven join line;
- c) Hammering (which is where the abutting faces deform, like chisel shafts under the effects of frequent hammer blows).

5.2.6 Whatever damage is found on compressor blades, its position on the blade will determine its seriousness. It is usual for the inner one-third of the blade to be classified as a 'no damage allowable' area, as are the areas on each side of mid-span shrouds.

5.3 **Combustion Section**

5.3.1 High temperature is the reason for most combustion section defects. Burning, cracking, distortion and erosion of nozzle guide vanes (NGVs) are typical. The combustion section may be inspected with an endoscope either through the designated access ports or through the igniter plug holes or burner apertures. The components visible depend, of course, upon engine design and the position of the access ports, but the flame tubes or liners, burner flares and swirlers, tube interconnectors and the NGV leading edges are normally inspectable.

NOTE: In the combustion section, all defects must be assessed on the basis of the likelihood of the defect causing a breakaway of material. This could lead to greater damage occurring in the turbine.

5.3.2 **Burners.** The burners protrude into the forward face of the flame tube/liner through an aperture which is usually flared; this is sometimes called the burner flare. The burner must be concentric with this flare otherwise a loose flare or burner should be suspected. In an annular combustion chamber, the burners and flares are separated by blank segments and these must be secure.

5.3.3 The burners may develop carbon deposits, which can be in the form of an irregularly-shaped protuberance from the burner face. In some engines this has a detrimental effect on starting, but when it breaks off it rarely causes any damage because it is usually soft. Hard carbon, however, can block the burner spray nozzle but does not grow large enough to cause break-off damage.

5.3.4 Swirlers (or swirl vanes) should be inspected for security and missing elements. All components should be inspected for cracks.

5.3.5 **Flame Tubes/Liners.** Flame tubes (or, in annular combustion chambers, the liners) contain the flame by directing air through holes or slots to the centre of the tube. The whole surface of the tube is peppered with cooling holes of varying sizes arranged in a regular pattern and these are usually the starting points for cracks and sometimes determine the limits of cracks. For instance, the Maintenance Manual may state that axial cracks which extend rearward beyond the third row of cooling holes are unacceptable. The allowable limits for cracks can depend on both their position and length. To assess their length through an endoscope must at times be a matter of

estimation. The engineer should, however, be aware of the general dimensions of the component being inspected (these are sometimes stated in the Maintenance Manual, otherwise familiarity with the components is required); from this a near estimate can be made of crack length. The flame tubes should be inspected for cracks and other damage as follows:

- a) **Cracks.** These start at holes or edges and may stop when they reach another hole or edge. Circumferential cracks can be more serious than axial cracks as they can result in pieces breaking off under the effect of airflow and flame impingement. Cracks around dilution chutes (scoops or nozzles into the airstream) are usually considered to be serious, since any distortion of the chute may create hot-spots which will accelerate deterioration and may cause torching of the flame onto the air casing.
- b) **Distortion.** Usually, defined limits give the allowable amount of distortion into the airstream and the length of cracks associated with it. The manufacture of a flame tube normally includes sections which overlap each other; these overlaps allow cooling air to flow near the surface of the tube. The sections are joined by a 'wiggletrip' (corrugated spacer) which allows air to flow through the overlap. The wiggletrips should be inspected for security because the welds can fail, causing distortion of the strips into the airstream of the tube. Limits for this damage are measured in numbers of adjacent or total wiggletrip pitches affected.
- c) **Burning and Hot Streaking.** The high temperature materials used for the flame tubes/liners sometimes change colour quite dramatically with heat, so coloured areas alone may not indicate serious burning. Burning is caused by the flame approaching the tube/liner and is recognised by the texture of the surface; this becomes rough and pitted and a reduction of wall thickness is noticeable. Streaks of metallic particles sparkle under the high intensity light of the endoscope and are recognised this way. Edges of lips and overlaps are susceptible to burning and erosion. Burn limits depend upon position and area.
- d) **Holes.** These can be caused in three ways:
 - i) pieces breaking off,
 - ii) cracks allowing a section of metal to be lifted off and
 - iii) burning through.

Holes in a flame tube/liner need not be a reason to reject an engine. However, the turbine should be inspected if the hole was caused other than by burning through. Carbon deposits produced at the burner can sometimes be mistaken for holes as the carbon is an intense black; the angle of view of the suspected hole should be changed if any doubt exists. If the suspected hole is a carbon deposit no detail of the edge of the 'hole' will be visible, neither will any detail through the 'hole'.

- e) **Nicks and Dents.** Inspection should be extended to the NGVs if this damage is found because these are evidence of broken-off particles or FOD.

5.3.6 **Nozzle Guide Vanes.** The NGVs are subject to very high thermal and mechanical stresses and only the newest of engines do not show physical signs of this when inspected through an endoscope. If viewed from the igniter plug holes, the leading edges and some concave surfaces only will be visible. Access ports are required elsewhere to view the whole surface of NGVs as they are highly cambered. Rows of cooling-air holes are visible on most NGVs and these may be used to identify areas of the vane. Damage can be as follows:

- a) **Discoloration.** Slight discoloration is nearly always present and is not necessarily a defect. Heavy discoloration, however, is associated with burning.
- b) **Cracks.** These are allowable to a limited extent but if associated with lifting of the surface from the original contour they are not acceptable. Cracks are either axial (from leading edge to trailing edge) or radial (vertical) and their allowable length will depend on their direction; those which converge or are in convex surfaces may well necessitate engine rejection.
- c) **Burning and/or Erosion.** Erosion, although caused separately from burning, is usually found in the same areas as burning and is subject to the same limits. Erosion is the product of abrasion and looks like burning without the discoloration; that is, roughness and pitting with a noticeable reduction in skin thickness. Burning and erosion are most common on NGV leading edges and concave surfaces. They may penetrate the outer skin and are sometimes allowable, but again subject to position and size of area affected.
- d) **Dents and Nicks.** These are caused by FOD and further inspections should be carried out if they are found.
- e) **Tearing.** Tearing can occur in trailing edges and is allowable only within defined limits.

5.4 Turbine Section

- 5.4.1 Access for the endoscope inspection of turbine blades is either through the ports provided or sometimes through the igniter plug holes using a flexible endoscope (flexiscope). For this, a holding tool can be made which is fed through the igniter plug hole and fixed. The flexiscope is then inserted and the holding tool guides the tip through the NGVs to view the blades. Methods of identifying blades are explained in paragraph 3.6.

NOTE: When viewing the aerofoil surface of a turbine blade, the end of the probe is located between the blades and must be withdrawn prior to engine rotation to avoid damaging the probe and blades.

- 5.4.2 Turbine blades are subject to the same types of damage and defects as NGVs. The limits for such damage are, however, more stringent. Blades can have some leading edge damage and cracking but still remain in service; trailing edge cracks, however, can propagate quite quickly due to tearing forces imposed by centrifugal force and the twist of the blade and these cracks are not normally allowable. Dents on aerofoil surfaces of hollow turbine blades can initiate cracks on the cooling-air passage wall inside the aerofoil section which can propagate to form quite large internal cracks before breaking through and becoming visible.
- 5.4.3 Deposits can form on most internal parts of gas turbine engines. When airborne sand is ingested it usually accumulates on the NGV and turbine blade leading edges. It has a sandy colour and becomes baked on by the combustion process and is not easily removed even at engine overhaul. It can cover some cooling holes but does not usually cover significant NGV or turbine blade defects. Its effect on inspections is therefore minimal, but its overall effect is to shorten engine life.

5.5 Record of Damage

- 5.5.1 When damage is found it must be recorded in the engine records. This is the case whether the inspection was routine or a special one. Increases in crack length, for instance, can then be assessed over a period of time, thus giving time to arrange for repairs or removal. Some operators have introduced inspection sheets for use when carrying out routine and special endoscope inspections. The sheets detail the preparation work necessary before inspection and also include drawings which depict

blades or flame tubes; engineers then mark in observed defects and identify the drawings accordingly. These representations of the internal state of each engine then form part of the engine's records and can be used in future assessments of damage and the growth of existing damage. Photographic records may also be kept, using a still camera or video tape recording.

- 5.5.2 The Maintenance Manual will sometimes define a defect as acceptable for a finite number of flying hours or cycles. Engineers should, therefore, ensure that additional entries are made in log books and/or technical logs to limit engine operation to the periods allowed. If, however, inspection reveals that different defects exist which are related, each with a finite allowable number of flying hours, the engineer should consider certifying such defects as allowable only for a shorter time than the most restrictive of the allowances given.

Chapter G Ground Operations

Leaflet G-10 Aircraft Handling

1 Introduction

This Leaflet describes the ground handling tasks which may be necessary during the normal day-to-day operation of an aircraft and details the procedures and precautions which are generally specified. These tasks vary considerably according to the size and type of aircraft concerned and the layout of the aircraft systems; this Leaflet should, therefore, be read in conjunction with the appropriate Maintenance Manual, where information relating to the particular aircraft will be found.

2 General

The tasks which may be required to be carried out on an aircraft between flights, apart from routine maintenance, cover a variety of subjects and these are dealt with separately in paragraphs 3 to 8 of this Leaflet. Special ground equipment is often required to enable these tasks to be carried out satisfactorily; in the case of light-aircraft operations this equipment may be of a very rudimentary nature, but when dealing with large transport aircraft more sophisticated equipment may be necessary.

2.1 Preparations for the reception of an aircraft should be made in advance of its arrival. The positioning of aircraft in the reception area should be arranged so that access paths to the aircraft are available for all replenishing vehicles and for the loading and unloading of passengers or cargo as applicable. All equipment likely to be required for the servicing of an aircraft should be readily available and should be in a fully serviceable condition.

2.2 When an aircraft has to be moved into a hangar in order to allow servicing operations or maintenance to be carried out, it should be positioned so as to avoid obstructing access to other working space or necessitating disturbance before the work is complete. Account should also be taken of the location of all necessary facilities such as weighing platforms, electric and pneumatic power sources, lighting and of the necessity for providing docks or platforms to enable the work to be carried out.

3 Towing

It is often necessary to move an aircraft without starting the engines, in order to position it for servicing or to enable passengers or cargo to be loaded, if this operation is not carried out properly, severe damage can be caused to the aircraft. Should it be necessary to call upon the assistance of untrained or inexperienced persons to move the aircraft, the person taking charge should instruct them adequately before starting and ensure that they fully appreciate what they are required to do. Paragraphs 3.1 and 3.2 contain general information on the towing of aircraft and the precautions to be observed, but detailed information relating to the movement of a particular aircraft will be found in the manufacturer's Maintenance Manual for the aircraft concerned.

3.1 **Light Aircraft**

Great care should be exercised when manhandling light aircraft, particularly those manufactured from wood and fabric.

- 3.1.1 On aircraft having a nose-wheel landing gear, a steering arm should be fitted to the nose wheel to guide the aircraft and force should be applied only to those parts of the structure which are designed to accept it. Force should not be applied to trailing edges of wings or control surfaces, to streamlined wires, or to areas which are marked to prohibit the application of force; an engine should always be regarded as 'live', therefore, a propeller should not be used to push or pull the aircraft.
- 3.1.2 Generally it is better to push an aircraft backwards rather than forwards, since the leading edges of the wings and tailplane are stronger than the trailing edges, but the struts and undercarriages on some aircraft are suitable for pushing the aircraft forwards. The flat of the hands should be used when pushing, so as to spread the load over the largest area, in addition when pushing on struts or undercarriages the force should be applied as near to the end fittings as possible.
- 3.1.3 On aircraft with a steerable nose wheel connected to the rudder pedals, care must be taken not to exceed the turning limits, which are normally marked on the nose undercarriage leg. On this type of aircraft it is also important that the rudder controls are not locked during towing operations.
- 3.1.4 On aircraft which are fitted with a tail skid instead of a tail wheel, it is customary to raise the tail by lifting on the tailplane struts near to the fuselage fittings, so that the aircraft is balanced at the main wheels; the aircraft may then be pushed backwards as required. On some aircraft it may also be advisable to place the propeller in a horizontal position, to prevent it striking the ground when the tail is lifted.
- 3.1.5 When towing a light aircraft by means of a tractor, the correct tow-bar should be connected between the towing attachment at the base of the nose undercarriage leg and the tractor; a person familiar with the aircraft brake system should be seated in the cockpit/cabin to operate the brakes in an emergency; the brakes should not normally be applied unless the aircraft is stationary. Once the tow-bar is connected, the brakes and, where fitted, the rudder lock, may be released and the aircraft towed forwards at a safe speed, depending on conditions in the vicinity. A close watch should be kept on the wing tips and tail, particularly in confined spaces, to ensure that they do not come into contact with other stationary or moving objects. Care should be taken when negotiating bends, to prevent the limits of nose-wheel movement being exceeded.
- 3.1.6 In circumstances where the ground over which the aircraft has to be towed is either boggy or very uneven, the strain imposed on the nose undercarriage may be excessive and it may be necessary to tow the aircraft by means of bridles attached to each main undercarriage. If towing attachments are not provided on the main undercarriage legs, ropes should be passed carefully around the legs as near to the top as possible, avoiding fouling on adjacent pipes or structure. A separate tractor should be connected to each main undercarriage and steering should be carried out by means of a steering arm attached to the nose wheel rather than by differential movement of the tractors.

3.2 **Large Aircraft**

Large multi-engined aircraft are usually moved by towing with a tow-bar attached to the nose undercarriage leg, a special tug often being required to provide sufficient tractive effort. The tow-bar is fitted with a shear-pin or bolt, which will shear at a

- predetermined load to prevent excessive force being applied to the nose undercarriage.
- 3.2.1 The centre-of-gravity (C of G) of the aircraft must be determined before towing, to ensure that there is sufficient weight on the nose wheel. Adverse fuel distribution and the aircraft being in a non-standard condition (e.g. with an engine removed), could affect the C of G position and a maximum aft limit is generally specified in the relevant Maintenance Manual. Ballast may sometimes be required to achieve a safe C of G position, but the maximum towing weight must not be exceeded.
 - 3.2.2 Before towing is commenced the undercarriage ground locks should be installed, the steering should, if applicable, be disconnected or disabled (usually by removing a steering disconnection pin, by inserting a lock-out pin, or by tripping the associated circuit breaker) and the nose undercarriage shock absorber should be checked for normal extension. In addition, the brake pressure should be checked and, if necessary, built up to the minimum safe pressure (this is often accomplished by operation of an electrically-driven hydraulic pump, which must be used sparingly to prevent the motor overheating). If it is likely to be necessary to turn the nose wheel through a greater angle than the prescribed steering limits, the nose wheel is usually freed by removing the apex pin from the torque links, thus allowing the nose wheel complete freedom of movement, but particular attention must be paid to any limits imposed on aircraft having bogie undercarriages.
 - 3.2.3 When towing the aircraft, two qualified pilots or suitably trained and authorised members of the towing crew should be stationed in the cabin, to operate the brakes and any of the other aircraft systems which may be required and to keep a look-out and monitor progress. These persons should be in telephonic communication with the outside ground crew and with the tractor driver. Ground crew should be located at the wing tips and tail to guide the aircraft past any obstructions. One person should be in overall control of the operation.
 - 3.2.4 The aircraft brakes should be released before the tractor moves off and towing-speed should be kept down to a safe speed. The radii of turns should be kept as large as possible, to minimise tyre scrubbing and twisting loads on the main undercarriage legs. Care should be taken not to exceed any towing-force limits which may be specified in the relevant Maintenance Manual for various nose-wheel steering angles. Before stopping, the aircraft should be towed in a straight line for a short distance in order to remove any tyre stresses imposed by turning. Once stationary the aircraft brakes may be re-applied, the tractor and tow-bar may be removed and the nose-wheel steering links refitted and safety locked.
 - 3.2.5 In circumstances where the towing load exceeds the nose-wheel limitations, towing bridles should be attached to the main undercarriage legs and the aircraft should be towed using two tractors, one connected to each main undercarriage leg. A steering arm attached to the nose wheel should be used for steering purposes. Where no special towing attachments are provided, it will often be necessary to remove the fixed doors from the main undercarriage legs to permit attachment of the towing bridles.
 - 3.2.6 In an emergency it may be necessary to move an aircraft from a runway while it has one or more deflated tyres. Provided that there is one sound tyre on an axle the aircraft may be towed to the maintenance area, but sharp turns should be avoided, towing speed should be kept to an absolute minimum and brakes should be applied very carefully. If an axle is not supported by a sound tyre, however, the aircraft may only be moved the shortest distance necessary to clear the active runway and the wheels with deflated tyres must be removed and serviceable components fitted before towing is continued. After any tyre failure the associated wheel must be

inspected (see Leaflet 32-20) and it may also be necessary to inspect the wheels and tyres which have not failed if the aircraft has landed or been towed with a deflated tyre.

4 Parking and Picketing

When an aircraft is out of service and in the open, it should be secured against inadvertent movement and protected against adverse weather conditions. The operations which are recommended in the relevant Maintenance Manual depend on the type of aircraft, the length of time it will be out of service and the prevailing or forecast weather conditions.

- 4.1 Between flights it is usually sufficient to apply the parking brakes, lock the control surfaces and chock the wheels, but in a strong wind light aircraft should be headed into wind. Light aircraft without wheel brakes should be headed into wind and their wheels should be chocked front and rear.
 - 4.1.1 Flying controls on many aircraft are locked by movement of a lever in the cockpit/cabin, which is connected to locking pins at convenient positions in the control runs or at the control surfaces. When this type of lock is not fitted, locking attachments may have to be fitted to the control column and rudder pedals, but a more positive method which is frequently used on older or elementary aircraft, is the fitting of external control surface locks, which prevent control surface movement and thus prevent strain on the control system. All external locks should have suitable streamers attached, to make it visually obvious that the locks are fitted.
- 4.2 If an aircraft has to be parked overnight or for longer periods in the open, then additional precautions should be taken to guard against the effects of adverse weather. The undercarriage ground locks should be fitted, all openings such as static vents, engine intakes and cooling air intakes should be blanked to prevent the ingress of dirt, birds, insects and precipitation and all fittings such as pitot heads and incidence indicators should be covered. When severe weather is expected it is recommended that cockpit/cabin covers and wheel covers are also fitted. Blanks and covers for all these components are specially designed for the particular aircraft and if not visually obvious, are fitted with streamers to guard against their being left in position when the aircraft is prepared for service; servicing instructions should, however, include a pre-flight check to ensure that all covers and locks have been removed.
- 4.3 Light aircraft should normally be tied down when parked overnight or longer, but this is not usually necessary with large aircraft unless particularly strong winds are expected.
 - 4.3.1 Light aircraft are fitted with picketing rings (or positions for the attachment of picketing rings) at the wings and tail and, on some aircraft, adjacent to the main undercarriage legs. The aircraft should be parked into wind and secured from the picketing points to suitable anchorage points on the ground (heavy concrete blocks or screw pickets). Cable or nylon rope of adequate strength should be used if possible, but if rope made from natural fibres is used, sufficient slack must be left to allow for shrinkage in damp conditions. Additional picketing from the undercarriage legs may be recommended in strong wind conditions and, if so, care should be taken not to damage any pipelines or equipment attached to the legs or wheels.
 - 4.3.2 Large aircraft only require picketing in very strong wind conditions. The aircraft should be headed into wind, the parking brakes should be applied (unless pre-loaded main-wheel chocks are recommended) and cables should be attached from the aircraft

picketing points to prepared anchorages. In some cases the picketing cables are special components and include a tension meter which is used when applying a pre-load to the cable.

- 4.4 For helicopters, in addition to the actions outlined in paragraphs 4.1 to 4.3, the rotor blades should be tethered whenever possible, since even light gusting winds can cause damage to blades which are free to flap. The collective pitch lever should normally be locked in the fully fine position and the rotor brake applied. Rotor head and blade covers should also be fitted if the helicopter is parked overnight, if high winds are expected it should be hangared or the rotor blades should be folded.
- 4.4.1 On many helicopters the main rotor blades are tethered by aligning one blade along the tail cone, locking the collective pitch lever in fine pitch and applying the tip covers to each blade, pulling them against the damper stops. Each blade may then be lashed to its respective picketing point, but care must be taken not to pull the blades down excessively; the relevant Maintenance Manual will generally stipulate a maximum distance from the normal drooped position which must not be exceeded. The tail rotor is generally tethered by fitting the blade covers and securing them to the associated picketing point or tail skid.
- 4.4.2 The method of folding the main rotor blades depends on the method of attachment to the rotor head and on the position of each blade; the procedure for a particular helicopter should, therefore, be obtained from the relevant Maintenance Manual. In the folded position the blade tips are generally secured by means of support cradles, which are attached to the tail cone structure.

5 Jacking

An aircraft may have to be jacked up for a variety of reasons, including servicing, weighing, changing wheels and retraction tests and care is necessary to avoid damaging the aircraft. Jacking points are provided in the wings and fuselage to enable the whole aircraft to be lifted, and usually, at the nose and main undercarriages to enable individual wheels to be changed. Some aircraft require a jacking pad to be fitted to each jacking point in the wings and fuselage and adapters to be fitted to the jacks, while in other cases special stirrups or beams may be required to lift individual axles.

- 5.1 Because of the position of the jacking points, the centre-of-gravity of some aircraft may, although satisfactory for flight, fall behind the main jacking points and thus be unsatisfactory for jacking purposes. In these cases it may be necessary to add ballast forward of the main jacking points to bring the centre-of-gravity within limits specified in the relevant Maintenance Manual. In addition, each jacking or steadying point may have a load limit which, if exceeded, could result in structural damage. To avoid exceeding the limiting load at the jacking points it is sometimes necessary to fit hydraulic or electrical load cells (see Leaflet 8-10) to the jacks, while ballast may have to be used to avoid exceeding the loading limit at a steadying point.
- 5.2 Micro-switches fitted to the undercarriage legs and operated by the extension or contraction of the shock absorbers, are used to arm or disarm various electrical circuits on an aircraft. If the aircraft is jacked up these circuits will operate as required during flight, this may not be desirable. Therefore, these circuits should be isolated by tripping the appropriate circuit-breakers or by removing the associated fuses, as necessary.
- 5.3 As a safety precaution, light aircraft should normally be jacked inside a hangar, but large aircraft may be jacked in the open provided that they are headed into wind and

that the surface is level and strong enough to support the weight of the aircraft at the jacking points. A maximum safe windspeed for jacking is generally specified in the relevant Maintenance Manual.

5.4 The following procedure will generally ensure the satisfactory jacking of most aircraft, but account should also be taken of any additional precautions or actions specified in the Maintenance Manual for a particular aircraft. One person should be located at each jacking position and a co-ordinator should supervise the operation. On large aircraft the levelling station (paragraph 6) should also be manned and all ground crew concerned should be in communication with the co-ordinator, headphones being used when necessary.

- a) Check that the aircraft weight, fuel state and centre-of-gravity are within the limits specified in the aircraft Maintenance Manual.
- b) Head the aircraft into wind if it is to be jacked in the open, chock the main wheels front and rear and release the brakes.
- c) If jacking an aircraft in a restricted space, ensure that there is adequate clearance above every part of the aircraft to allow for its being raised and adequate access and lifting space for cranes or other equipment which may be required.
- d) Connect earthing cables to the earthing points on the aircraft.
- e) Install the undercarriage ground locks.
- f) Fit jacking pads to the aircraft jacking points and adapters to the jacks as required. Load cells should also be fitted to the jacks at positions where a maximum jacking load is specified.

NOTE: The capacity and extension of the jacks should be adequate for the aircraft size and weight. The minimum requirements will normally be stated in the relevant Maintenance Manual.

- g) Position the jacks at each jacking point and raise them until the adapters are located centrally in the jacking pads. Care must be taken to ensure that the jacks are vertical and that the weight is evenly distributed over the legs of each jack.
- h) Remove the wheel chocks and slowly raise the aircraft, maintaining it in a horizontal attitude as nearly as possible, until the undercarriage legs are fully extended and the wheels are a few inches off the ground. As a safety measure the locking nuts on the jack rams should be kept in close proximity to the jack shoulders as the jacks are raised.
- i) Tighten the jack ram locking nuts and place supports under the outer wings and rear fuselage as indicated in the Maintenance Manual. The positioning of these supports is most important, as they are usually shaped to fit the undersurface of the wing or fuselage and must be located at a strong point such as a rib or frame; they are not intended to support the weight of an aircraft.

5.5 A 'bottle' jack and an adapter or special fitting are often used when raising a single undercarriage or part of a bogie beam for the purpose of changing a wheel. The remaining wheels should be chocked front and rear to prevent aircraft movement, it may also be specified that a tail support is located at the rear fuselage jacking point when raising a nose undercarriage. The jack should be raised only sufficiently to lift the unserviceable wheel a few inches clear of the ground (lowering the tail support, when applicable, as the jack is raised). Any applicable safety precautions outlined in paragraph 5.4 should be observed.

5.6 Before lowering an aircraft to the ground, all ground equipment, work stands, supports, etc., should be moved clear of the aircraft structure to prevent inadvertent

damage, the wheels should also be rotated by hand to check that the brakes are free. The jacks should be lowered slowly in unison, by opening their pressure release valves, and, to guard against failure of a jack, the locking nuts on the jack rams should be unscrewed while the jacks are lowered and kept within 50 mm (2 in) of the jack heads. The jacks should be fully lowered after the aircraft is resting on its wheels and the pressure release valves should be closed. Chocks should then be placed in position, the jacks, jacking pads and adapters should be removed from the aircraft and any electrical circuits which were disarmed as a safety measure should be reinstated.

NOTE: Undercarriage shock absorbers occasionally stick in the extended position, care should, therefore, be taken not to leave any equipment in a position beneath the aircraft where it could cause damage, until it is certain that the shock absorbers have compressed.

6 Levelling

For some purposes, such as rigging or weighing, an aircraft must be levelled laterally and longitudinally and a number of different methods may be employed.

6.1 Spirit Level

Many aircraft are levelled by use of a spirit level, which is placed at jugged positions on the airframe structure. On light aircraft the longitudinally level position is generally obtained by placing the spirit level on two pegs or on the heads of two partially withdrawn screws on the side of the fuselage and adjusting the jacks (or the shock absorber extension or tyre pressures, if the aircraft is resting on its wheels) until the spirit level is centred. The laterally level position is obtained by placing the spirit level on the centre-section spar boom (or other nominated position) and again adjusting the jacks or tyre pressures until the level is centred. With some large aircraft a spirit level may be used in conjunction with special fittings, which are secured by locations in the centre fuselage or in one of the wheel bays; these fittings must be removed before flight and should have warning streamers attached. If adjustments have been necessary to level an aircraft laterally, the longitudinal level should be re-checked.

NOTE: In cases where tyre pressures are adjusted to level the aircraft, care must be taken not to over-inflate or to completely deflate a tyre.

6.2 Plumb Bob

On many aircraft a plumb bob is used in conjunction with a levelling plate. The plumb bob is suspended from a fixed position in the cabin roof or upper part of a wheel bay and hangs over a levelling plate, which may be a permanent fixture or a separate fitting accurately located on the cabin floor or lower part of the wheel bay. The levelling plate is marked with a zero position and scales indicating the adjustments required about the lateral and longitudinal axes to centre the plumb bob.

6.3 Engineers Transit

The most accurate means of levelling an aircraft is by the use of an engineers transit (theodolite) in conjunction with range poles or scales located on the aircraft's lateral and longitudinal axes. The transit is set up below the aircraft centreline and between the lateral levelling points and levelled horizontally. Range poles or scales are then located at the four marked levelling points on the lower surfaces of the fuselage and wings. Sightings are first taken on the lateral range poles or scales and the main jacks are adjusted until identical readings are obtained. Sightings are then taken on the longitudinal range poles or scales and the nose jack is adjusted until identical readings are again obtained. The aircraft is then considered level and the transit can be removed.

NOTE: The transit method is also employed when checking alignment of the aircraft structure, graduations on the range poles being used to check dihedral and incidence.

7 Servicing

Servicing may often be carried out in a crowded environment and must be properly organised to ensure that the necessary operations are carried out, to provide adequate safety to passengers and ground crew and to protect the aircraft from damage. The procedures and precautions generally applicable to the routine servicing of aircraft are dealt with in the following paragraphs.

NOTE: For the purposes of this Leaflet, the term 'servicing' means those operations which are required to check and replenish an aircraft's systems and to maintain an aircraft in an operational condition. In cases where an aircraft Maintenance Manual is produced in accordance with ATA Specification 100, detailed information on servicing operations will be found in Chapter 12.

7.1 General

The maintenance of a satisfactory surface contour and finish on an aircraft is most important and care is necessary to prevent damage to outer surfaces, access panels and fasteners. Walkways are provided on the wings of many aircraft for access to the cockpit/cabin or for servicing purposes and areas which must not be trodden upon, pushed or pulled, are clearly marked. Mats and suitable rubber footwear must be used when it is necessary to walk on the wings and every precaution should be taken to prevent damage by tools or servicing equipment. It is also advisable to wear clothing without buttons or buckles which could scratch the wing surface, and, without pockets in which loose tools could be carried, since they could fall out and become a loose-article hazard.

7.2 Ground Equipment

Many types of ground equipment may be required during aircraft servicing and all must be compatible with the aircraft systems on which they are to be used. The ground equipment should be kept scrupulously clean and should be maintained in accordance with a schedule recommended by the manufacturer. Delivery pipes from all liquid and gas servicing trolleys should be blanked when not in use and their cleanliness and serviceability should be checked before connection to an aircraft. Fire extinguishers suitable for fuel and electrical fires should always be readily accessible wherever an aircraft is being serviced and should be subject to regular inspection.

7.3 Refuelling

Before refuelling it should be ensured that the refuelling vehicle contains the correct grade of fuel, as shown at the refuelling points on the aircraft.

- 7.3.1 Precautions should be taken to provide a path to earth for any static electricity which may be present or which may build up as a result of the fuel flow. The aircraft and the refuelling vehicle should be earthed to a point which is known to be satisfactory and the earthing wire on the refuelling pipe should be connected to the earth point provided on the aircraft before connecting the refuelling pipe or removing the tank filler cap. The earthing wire should remain in position until after the refuelling pipe is disconnected or the tank filler cap is replaced, as appropriate. When draining fuel into buckets, containers or tanks, these should also be bonded to the aircraft and/or the refuelling vehicle. No radio or radar equipment should be operated while refuelling or defuelling is taking place and only those electrical circuits essential to these operations should be switched on.

7.3.2 When pressure refuelling, a float switch or fuel level shut-off valve is often used to cut off fuel flow when the tanks are full, or have reached a pre-set level. Since pressure refuelling rates are very high, failure of these components could cause a rapid build-up in pressure and serious damage to the tanks. The tanks of some aircraft are fitted with pressure relief valves which can be checked manually prior to refuelling, but when this is not the case persons engaged in refuelling operations should be prepared to shut off the supply instantly, should the automatic cut-off system fail to operate.

NOTE: When refuelling, the wheel chocks should be moved a short distance away from the tyres, to prevent them being trapped when the tyres absorb the additional weight.

7.3.3 Particular care should be taken when refuelling high-winged light aircraft, since the upper wing surface will not normally be safe to walk on and the filler cap may not be within easy reach. A step ladder or stand should be used to gain access to the filler cap and assist in preventing damage to the wing surface. Use of the steps will also facilitate correct locking of the filler cap.

7.3.4 When a spillage of fuel has occurred, care should be taken to ensure that all traces of fuel and vapour are removed. Any residual fuel should be mopped up and any fuel-soaked lagging or fabric should be removed and cleaned. The effects of the fuel on other parts such as cables, seals, bearings and windows should also be considered and the appropriate action should be taken.

7.3.5 After refuelling an aircraft it is usually recommended that fuel is checked for contamination. Drain valves are provided in the tank sumps, pipelines and filters, by means of which a small quantity of fuel may be drained into a glass jar and checked for the presence of water, sediment and microbiological contamination. Because of the slow rate of settlement of water in turbine fuels it is usually recommended that the tanks are left as long as possible after refuelling before the sample is taken. With turbine-engined aircraft, samples may also be taken to determine the specific gravity of the fuel in the tanks.

7.4 **Connection of Electrical Power**

It is often necessary to connect an external electrical power supply to an aircraft, either for engine starting purposes or to permit operation of the aircraft systems and equipment. Certain precautions must be observed when connecting the external supply, to prevent damage to the aircraft electrical system.

7.4.1 Most light aircraft have direct current (d.c.) electrical systems and although alternating current (a.c.) is provided for the operation of certain equipment it is not usual for the aircraft to have provision for the connection of a.c. external power. The external power socket is, therefore, usually for the connection of a d.c. supply, which may be provided solely by batteries or from a generator and battery set. The following actions should be taken when connecting an external d.c. supply to a typical light aircraft:

- a) Check the voltage and polarity of the ground supply.
- b) Check that the external power plug and socket are clean, dry and undamaged.
- c) Check that the external supply and the aircraft battery master switch are off and connect the external supply, ensuring that the plug is fully home in the socket.
- d) Switch on the external supply and the aircraft battery master switch and carry out the servicing operations for which the external power was required.
- e) To disconnect the external supply, switch off the battery master switch, switch off the external supply, disconnect the external power plug and, if the aircraft electrical

system is to be used (e.g. after engine starting), switch the battery master switch on again.

7.4.2 Most large aircraft are provided with multi-pin plugs or sockets, by means of which external d.c. or a.c. power may be connected into the aircraft electrical system. The external supply is usually provided by a towed or self-propelled unit, which has its own power-driven generator and can provide d.c. power at various voltages and a.c. power at a particular voltage, frequency and phase rotation. Aircraft electrical systems vary considerably and the checks which are necessary after connecting the external power will vary between aircraft, but the following procedure is applicable in most cases:

- a) Check that the external supply is compatible with the aircraft system (i.e. it has the same voltage, frequency and phase rotation as the aircraft system) and is switched off.
- b) Check that the external plug and socket are clean, dry and undamaged.
- c) Connect the external plug/socket, ensuring that it is fully mated and secure and switch on the external power supply.
- d) Check the voltage and frequency of the external supply on the aircraft electrical system instruments and perform the operations specified in the relevant Maintenance Manual to engage the external supply with the aircraft a.c. system.
- e) To disconnect the external supply, disengage it from the aircraft a.c. system, switch off the external power at source and remove the external power plug/socket.

7.5 **Connection of Compressed Gases**

Any component containing compressed gas must be handled and serviced carefully, because the sudden release of gas under pressure could have disastrous consequences. Oxygen systems present an additional hazard in that oil and grease are prone to spontaneous combustion in the presence of undiluted oxygen.

7.5.1 The gas pressure required in some components varies according to the ambient temperature and in order to ensure that the correct working pressure is maintained, the relationship between temperature and pressure is generally presented in the form of a graph, both in the Maintenance Manual and on a placard adjacent to the charging point. In the case of tyres and shock absorbers on large aircraft the required gas pressures may vary according to the aircraft weight and centre-of-gravity position, the requirements for a particular aircraft should be obtained from the relevant Maintenance Manual.

7.5.2 Since the rapid compression of a gas produces heat it will affect the gas pressure in a component; heat will be minimised by charging slowly. The sudden release of a compressed gas will have the reverse effect, i.e. lowering its temperature and this is particularly important when deflating a tyre (see Leaflet 32-10), as ice may form and block the valve, giving the impression that the tyre is fully deflated when in fact it is still partially inflated. Prior to working on any unit from which compressed gas has been exhausted, the charging valve or valve case should be completely removed.

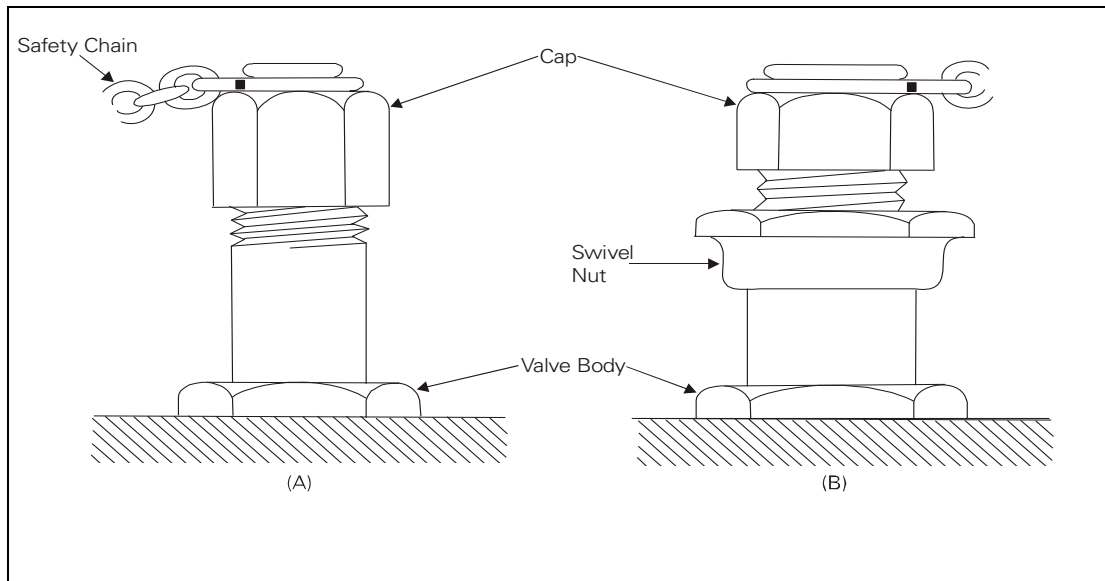

Figure 1 Charging Valves

7.5.3 Charging Valves

The valves fitted to components which are charged with gas may be of two types. One is a needle-type valve (Figure 1(A)) which opens and closes automatically, the other is a poppet-type valve on which the swivel-nut has to be unscrewed one full turn to release the valve stem (Figure 1(B)). A valve cap should always be fitted to prevent the entry of dirt and moisture and should be removed only when it is necessary to charge the component or to release gas pressure. On no account should the valve body be unscrewed while the component is pressurised, since this could result in the valve blowing out and causing damage or injury.

7.5.4 Charging Rigs

A compressed-gas charging rig is generally a self-propelled or towed trolley, on which are mounted one or more high-pressure gas cylinders, a flexible supply hose, a supply shut-off valve and pressure gauges showing storage cylinder pressure and supply hose pressure. Some rigs are also fitted with a pressure regulator, by means of which the supply pressure may be limited to the maximum required in the component, this type of rig is used when the aircraft system does not have its own supply shut-off valve and pressure gauges.

7.5.5 Charging

Charging a component with compressed gas should be carried out carefully and the following precautions should be observed:

- The pressure to which the component is to be charged should be checked according to the ambient temperature, or weight and centre-of-gravity of the aircraft, as appropriate.
- The supply connection should be clean, dry and free from oil or grease; any contamination should be wiped off with a lint-free cloth moistened in a solvent such as methylated spirits.
- The aircraft system should be charged very slowly, so as to minimise the rise in temperature.

- d) When the required pressure is reached, the shut-off valve should be closed and the system pressure allowed to stabilise. The pressure should then be checked and adjusted as necessary.
- e) The supply hose should not be disconnected unless the shut-off valve and the charging valves are closed, because of the dangers associated with rapid decompression. On some rigs provision is also made for relieving pressure from the supply hose before disconnection.
- f) Blanking caps should be fitted to the charging valve and supply hose as soon as they are disconnected.
- g) When charging oxygen systems, adequate and properly manned fire-fighting equipment should be positioned and, if illumination is required, explosion-proof lamps and hand torches should be used.

7.6 Replenishment of Liquids

On modern aircraft, replenishment of engine oil, hydraulic fluid, de-icing fluid, water and other systems containing liquids, is achieved by the use of servicing trolleys which are specially designed for the task and are connected into the system by quick-release couplings; alternatively, and with older aircraft, these systems may be replenished by removing the tank filler cap and pouring in the required liquid. Whichever method is used, the utmost care should be taken to ensure that only the approved liquids are used and that no foreign matter is allowed to enter the system. Servicing trolleys should be inspected regularly for cleanliness and their delivery pipes should be capped when not in use; all utensils should be kept scrupulously clean and should, preferably, be retained for use with one particular liquid.

7.6.1 The quantity of liquid in a system may be indicated by a sight glass, by use of a dipstick, by its visible level in a filter fitted in the filler opening, or, in some cases, by means of a contents gauge, the transmitter unit for which is mounted in the tank. When required, the system should be replenished to the 'full' level; no system should be overfilled, as this could affect system operation.

7.6.2 Precautions applicable to the replenishment of systems containing liquid are outlined in paragraphs a) to d) below:

- a) Some systems are pressurised in normal use and this pressure should be released before replenishing with liquid.
- b) When replenishing a hydraulic system, it may be necessary to pre-set the hydraulic services to specified positions to prevent overfilling.
- c) Some liquids, such as methanol, synthetic lubricating oils and hydraulic fluid, may be harmful or even toxic if their vapours are breathed in or if they come into contact with the skin or eyes.

Particular note should be taken of any warnings of dangers to health which may be contained in the relevant Maintenance Manuals and the recommended procedures for the handling of these liquids should be observed.

- d) The liquids mentioned in paragraph c) may also have an adverse effect on paintwork, adhesives and sealant and thus inhibit corrosion prevention schemes. Care should be taken not to spill any of these liquids, but if a spillage does occur, immediate steps should be taken to mop it up and clean the affected area.

7.7 Lubrication

Lubrication should be carried out in accordance with a schedule approved for the particular aircraft, the intervals normally being related to flying hours, with certain

positions requiring additional lubrication after ground de-icing operations (see CAP 512) and after cleaning the aircraft.

- 7.7.1 The lubricant to be used, and the method of application, are usually annotated on a diagram of the aircraft in the appropriate chapter of the aircraft Maintenance Manual. The method of annotation is often by the use of mimic diagrams (e.g. an oil can for oiling or a grease gun for greasing) and the type of lubricant is indicated by a symbol.
- 7.7.2 The utensils used for lubrication purposes should be kept scrupulously clean and should only be filled with new lubricant. Each utensil or container should be clearly marked with the lubricant it contains and should be kept solely for that lubricant.
- 7.7.3 When lubricating a component, care should be taken to ensure that the quantity applied is adequate but not excessive; in some cases a particular quantity may be specified in the Maintenance Manual (e.g. 'apply 8 drops of oil...') but normally a quantity sufficient to cover the bearing surfaces, as evidenced by the exuding of new lubricant, should be applied. The lubricating point should be wiped clean and dry with a lint-free cloth before applying the oil or grease, any excess exuding from the component should be wiped off to prevent the accumulation of dirt or foreign matter.

7.8 **Cleaning**

Cleaning an aircraft improves its appearance and aerodynamic qualities, helps to prevent corrosion and facilitates the detection of fluid leakage. It is, therefore, often included in the servicing schedule.

7.8.1 **Exterior Surfaces**

Before washing down the exterior surfaces of an aircraft, all doors and windows should be closed, all apertures such as air intakes, engine exhausts, fuel jettison pipes, static vents and vent pipes should be blanked, covers should be fitted to pitot heads and sensor vanes. Transparencies should be covered to prevent contamination by cleaning fluids. The structure should be washed down using a cleaning agent recommended by the aircraft manufacturer and mixed according to the instructions provided, caked mud or other foreign matter being removed with lint-free cloth soaked in the cleaning agent. The wash should be followed by swabbing with clean water and care should be taken to prevent cleaning fluid or water becoming trapped in parts of the structure where corrosion and seizure of mechanisms could result. The aircraft should be thoroughly dried after washing and rinsing. It is usually recommended that lubrication should be carried out, particularly if pressure hoses have been used.

- a) If it is necessary to remove concentrations of oil or grease, a cloth moistened in solvent should be used, but chlorinated solvents should be avoided since they may be toxic. The minimum quantity of solvent should be applied, since prolonged saturation of parts may have an adverse effect upon adhesives and jointing compounds. When solvents are used, adequate fire-fighting equipment should be available.

7.8.2 **Internal Structure**

Internal structure is generally cleaned with a vacuum cleaner, but a cleaning agent and water may be used when necessary. Only a small area should be washed, rinsed and dried at a time, so as to prevent flooding of the structure and trapping of fluids in inaccessible places. Clean lint-free cloths should be used for all operations and the structure should be finally dried by circulating warm air.

7.8.3 **Engines**

An engine and its compartment should be cleaned by spraying or brushing with solvent or degreasing fluid, after first blanking all vents and apertures in such components as the magnetos and alternator. This solvent should be left on for five to ten minutes, then the engine should be washed with clean solvent and allowed to dry. All controls, hinges, etc., should be lubricated after cleaning and the engine should not be operated until all solvent has evaporated or otherwise been removed. The precautions stated in paragraph 7.8.1 a) regarding the use of solvents should be observed.

7.8.4 **Upholstery**

Soiled carpets and seats may usually be cleaned by means of a vacuum cleaner and an approved non-flammable air-drying type cleaner or foam-type upholstery cleaner. The manufacturer's instructions for the use of these materials should be carefully followed, soaking or harsh rubbing should be avoided.

7.9 **Cold Weather Operations**

Particular care is essential in the operation of aircraft when temperatures are likely to fall below freezing point at ground level. When snow or ice is present towing and taxiing should be carried out with extreme caution and aircraft movements should be kept to a minimum; parking areas should, if possible, be cleared of snow and ice, so as to prevent aircraft tyres from freezing to the ground. If sand or grit is used to increase the tractive effort of tractors or assist the braking of aircraft, care should be taken to prevent these materials being drawn into operating engines; taxiways and hard standings should be swept to remove any sand or grit after the snow and ice have melted.

7.9.1 **After Flight**

When parking an aircraft, all covers, plugs and ground locks should be fitted as soon as possible. If the airframe is wet or affected by snow or ice, the surface under the covers should be given a light coating of anti-freeze liquid; anti-freeze liquid should not, however, be applied to the windows, since it has an adverse effect on plastics materials. Engine covers should be fitted as soon as the engine has cooled sufficiently, but in the case of turbine engines an inspection should be made for the presence of ice in the air intake, since this could melt while the engine is hot, drain to the lowest part of the compressor and subsequently re-freeze when the engine cools, locking the lower compressor blades in ice. If ice is present it should be allowed to melt, then removed before finally fitting the covers. Drain valves in the fuel and pitot/static systems should be opened to remove any accumulation of water. Domestic water, toilet systems and water injection tanks should be drained or treated with anti-freeze liquid as appropriate.

7.9.2 **Before Flight**

All external surfaces must be free of snow, frost or ice before an aircraft takes off and de-icing operations should be carried out as necessary (see CAP 512). Particular care is necessary when an aircraft has been removed from a heated hangar into falling snow since the snow will melt on the warm aircraft then re-freeze as it cools down, forming a thin layer of ice which may not be easily visible. Water systems should be filled with warm water and all covers should be kept in place until as near to departure time as possible.

8 Engine Starting and Running

An engine should not be ground run more often than is absolutely essential to ensure its serviceability. With a piston engine more wear takes place during cold starts than during normal operation and with a turbine engine the engine life may be directly related to the number of temperature cycles to which it is subjected. It is, however, frequently necessary to run an engine to check its performance; in these cases and when starting an engine prior to flight, certain precautions are necessary to ensure the safety of the aircraft, of surrounding aircraft and of personnel.

8.1 General Precautions

8.1.1 An aircraft should, whenever possible, be headed into wind before starting its engines. This is particularly important with light piston-engined aircraft as the wind direction will affect the engine speed obtained during checks and from certain directions could produce vibration and may adversely affect engine cooling. Turbine-engined aircraft are not usually affected so seriously by wind direction, but a strong tail wind could result in increased jet pipe temperatures during starting; care should also be taken not to engage the starter of a turbo-propeller engine if the propeller is being rotated backwards by the wind.

8.1.2 An aircraft should normally be parked with brakes on and chocks in front of the main wheels. The ground immediately in front of the propellers or intakes and beneath and behind the aircraft, should be checked for loose gravel or other foreign objects which could be drawn into the engine, cause damage to the propeller, or be blown against other aircraft, buildings and personnel. Jet blast can also have serious consequences and diagrams will be found in the Maintenance Manuals of turbine-powered aircraft showing the extent and velocity of the blast created at various power settings and the areas which should be kept clear of personnel and equipment. These diagrams also indicate the extent of the danger areas in front of the engines, which result from intake suction. When specified, intake guards should be fitted to turbine engines when they are run for maintenance purposes. A look-out man should be stationed in front of the aircraft and should be in visual and/or radio contact with the cockpit/cabin crew.

8.1.3 Whenever an aircraft engine is being started, adequate fire-fighting equipment should be readily available and manned.

8.2 Piston Engines

Piston engines are generally fitted with electric starter motors and an external power source should be connected to the aircraft whenever possible. When cold, engines should always be turned at least two revolutions before being started, to free the reciprocating and rotating parts and to determine whether a hydraulic lock (oil draining into the lower cylinders) has formed. The engine should normally be turned over by hand but when this is not possible the starter may be used. The magneto switches must be 'off' when turning the engine and the engine must always be treated as 'live', in case the switches are defective and not earthing the magneto primary circuits.

8.2.1 Piston-engine installations vary considerably and the method of starting recommended by the aircraft manufacturer should always be followed. Engine speed should be kept to a minimum until oil pressure has built up and the engine should be warmed up to minimum operating temperature before proceeding with the required tests. High power should only be used for sufficient duration to accomplish the necessary checks, since the engine may not be adequately cooled when the aircraft is stationary. After all checks have been carried out the engine should be cooled by running at the recommended speed for several minutes, the magneto switches

should be checked for operation and the engine should be stopped in the appropriate manner.

8.2.2 Extreme care is essential when starting piston engines by hand swinging. Many accidents have occurred in this way and both pilots and maintenance personnel should be given demonstrations and be checked out on this method of starting before being allowed to hand swing a propeller. The engine must always be treated as 'live' and no part of the arms, legs or body should be moved into the propeller disc at any time. No attempt should ever be made to start an engine without someone in the cockpit/cabin to operate the throttle or brakes as necessary, or without chocks placed in front of the wheels. A set sequence of calls and responses should be used to ensure that the ground crew and the pilot are fully aware of the actions being taken.

- a) **Sucking-in.** To prime the engine cylinders, when necessary, the ground crew should stand away from the propeller, face the pilot and call 'Switches off, petrol on, throttle closed, suck in'. The pilot should repeat these words, carrying out the appropriate actions at the same time. The ground crew should then set the propeller to the beginning of a compression stroke and turn the engine through at least two revolutions. Starting at the position shown in Figure 2, the propeller should be swung by moving the arm (right in this case) smartly down and across the body, turning away from the propeller and stepping away in the direction of movement of the aircraft.
- b) **Starting.** The ground crew should set the propeller at the start of a compression stroke (as in Figure 2), stand away from the propeller, face the pilot and call 'Contact'. The pilot should set the throttle for starting, switch on the magnetos and repeat 'Contact'. The ground crew should then swing the propeller as outlined in paragraph a). If the engine does not start, the ground crew should ensure that the magnetos are switched off before re-setting the propeller and switched on again before making another attempt to start the engine.

NOTE: The manufacturer's manual should be referred to for the operation, during starting, of magnetos which are fitted with impulse starters or retarded contact breakers.

- c) **Blowing-out.** If the engine fails to start through over-richness, the ground crew should face the pilot and call 'Switches off, petrol off, throttle open, blow out'. The pilot should repeat these words, carrying out the appropriate actions at the same time. The ground crew should then turn the propeller several revolutions in the reverse direction of rotation to expel the mixture from the engine. This will usually entail swinging the propeller up from the 6 o'clock position (approximately), using the opposite hand. The throttle should then be closed, the petrol turned on and the operations outlined in paragraph b) continued.

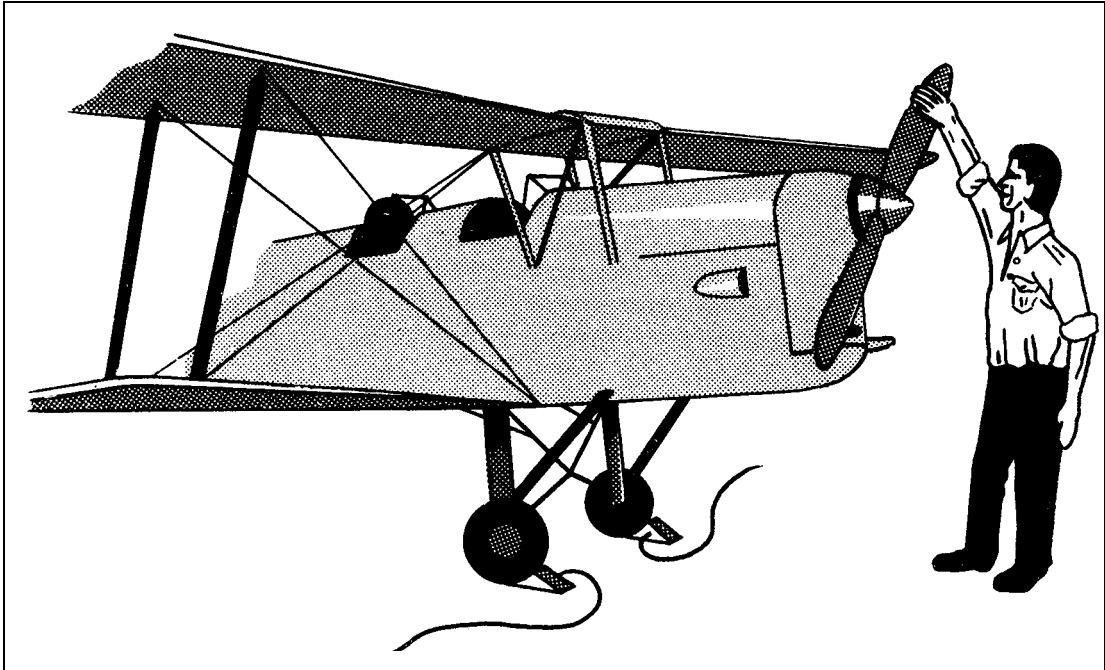

Figure 2 Hand Swinging

8.3 Turbine Engines

Turbine engines may be started by an electric motor or by an air turbine and may use either an internal power unit or an external power source to provide the necessary power. The danger areas in front of and behind the engines should be kept clear of vehicles and personnel and, if an auxiliary power unit is being used, from the vicinity of this exhaust also. Vehicles supplying electrical power or compressed air should be located in such a position that they can be moved away quickly in the event of an emergency. Qualified personnel should be located outside the aircraft and be in telephonic communication with the cabin crew, so as to be able to provide warning of situations not visible from the cabin and to prevent vehicles or personnel from entering the danger areas. Air intakes and exhaust pipes should be inspected for loose objects or debris before starting the engines.

INTENTIONALLY LEFT BLANK

Leaflet G-20 Fire – General Precautions

1 Introduction

This Leaflet deals with fire precautions during maintenance and engine running and indicates some of the maintenance and inspection procedures concerned with fire prevention. Some general information on the causes of aircraft fires is also included. The Leaflet should be read in conjunction with the relevant manuals for the aircraft concerned, the Factories Act and any local regulations concerning the prevention of fire. CAP 748¹ gives guidance on the fire prevention measures which should be taken when fuelling and de-fuelling aircraft.

2 Prevention of Fire on the Ground

2.1 Personnel engaged in the maintenance, overhaul and repair of aircraft, should be fully conversant with the operation of fire protection equipment provided and the action to be taken in the event of discovering a fire. Supervisors should satisfy themselves that all reasonable safety precautions are taken and that all apparatus is completely serviceable. Personnel should not wear footwear with exposed iron or steel studs, nails or tips in hangars, fuelling and de-fuelling areas and aircraft movement areas and it is recommended that matches or other means of ignition should not be carried.

2.2 Fuelling Operations

2.2.1 Personnel concerned with fuelling should be fully conversant with the guidance material in CAP 748, with local aerodrome instructions and with the safety precautions detailed in the relevant aircraft Maintenance Manual. Fuelling should only be carried out at a site approved by the aerodrome authority and the precautions outlined in paragraphs 2.2.2 to 2.2.8 should be observed.

2.2.2 Fuelling Zones

Fuelling zones should be established before fuelling commences. These zones should be regarded as extending at least 6 m (20 ft) radially from the filling and venting points on the aircraft and fuelling equipment. Within this zone, smoking, the use of naked lights and the operation of switches which are not of an approved pattern should be forbidden:

- a) Unless fuelling takes place in a designated no smoking area, 'No Smoking' signs should be displayed not less than 15 m (50 ft) from the fuelling equipment and aircraft tank vents.
- b) Auxiliary Power Units (APUs) which have an exhaust discharging into the zone should, if required to be in operation during fuelling, be started before filler caps are removed or fuelling connections made. If an APU is stopped for any reason during a fuelling operation it should not be started again until fuelling has ceased and there is no danger of igniting fuel vapours.
- c) Ground Power Units (GPUs) should be located as far as practical from aircraft fuelling points and vents and should not be connected or disconnected while fuelling is in progress.
- d) Fire extinguishers should be located so as to be readily accessible.

1. CAP 748 is available on the CAA web site at www.caa.co.uk under the Publications section. Paper copies are available from the CAA's printers whose details are given on the inside cover of this publication.

2.2.3 Precautions Prior to Fuelling

Before the transfer of fuel commences, the following procedure should be carried out:

- a) The aircraft should be connected to an effective earthing point and to the fuelling equipment.
- b) When overwing fuelling, the nozzle of the hose should be bonded to the aircraft structure before removing the tank filler cap. When fuelling from hand-operated equipment, including pumping from cans or drums, similar precautions should be taken to bond the pumping equipment, hose nozzle and containers. If funnels are used they too should be bonded to the nozzle or can and to the aircraft. If a chamois leather filter is used, the funnel and all metal parts securing the leather, should be included in the bonding circuit.
- c) When pressure fuelling, the fuel tank pressure relief valves should, if possible, be checked for correct operation and the bonding lead on the fuelling hose should be connected to the receptacle, located adjacent to the fuelling point, before connecting the nozzle.

2.2.4 Precautions During Fuel Transfer

- a) When overwing fuelling, the amount of fuel required should be determined and the quantity of fuel delivered should be regulated so that no overflow occurs. Fuel should not be splashed nor allowed to run into the aircraft structure.
- b) When pressure fuelling, any fuel levelling devices between tanks should be operated as necessary. The correct sequence of operations is essential to avoid damage to tanks and subsequent leakage of fuel or vapour.

2.2.5 Precautions After Fuelling

When the transfer of fuel is completed, the bonding wires should not be removed until the filler caps have been refitted or the pressure fuelling hose disconnected, as appropriate.

NOTE: Any cables, clips and plugs used for bonding or earthing, should be maintained in good condition and should be regularly tested for continuity.

2.2.6 Work on Aircraft During Fuelling

Whilst fuelling is in progress, servicing, maintenance, test and repair activities within the fuelling zone should be closely controlled.

- a) All ground equipment such as trestles, jacks, steps, etc., should be moved clear of the aircraft, to prevent damage to the aircraft as it settles because of the weight of fuel being uplifted.
- b) The main aircraft engines should not be operated.
- c) Only those electrical circuits essential to the fuelling operation should be switched on, except that some operators may permit certain specified maintenance work to be carried out during kerosene fuelling. The maintenance permitted is usually restricted to the replacement of complete unit assemblies. Testing and functioning of defined systems and equipment may be continued unless fuel spillage occurs or fuelling equipment becomes defective. No maintenance work may be permitted on aircraft using fuels which present a higher degree of fire hazard.
- d) Strobe lighting should not be operated.
- e) The engines of vehicles normally employed for servicing aircraft, including those on electrically powered vehicles, should not be run within the fuelling zone unless

they have been designed for the purpose. All vehicles, their engines and equipment, should be subjected to regular inspection and maintenance to preserve their safety characteristics.

- f) All connections between ground equipment and an aircraft should be made before fuelling equipment is connected and should not be broken until fuelling has been completed.
- g) Battery trolleys may be used within the fuelling zone provided that connection is made to the aircraft before fuelling equipment is connected. The circuit should remain unbroken until fuelling has ceased.
- h) Vehicles operating in the fuelling zone should not pass under or park beneath an aircraft unless specifically required to do so for maintenance or fuelling purposes. A clear exit path should be maintained.
- i) Aircraft combustion heaters should not be used.
- j) Maintenance work which may create a source of ignition should not be carried out in the vicinity of tanks or fuelling equipment.
- k) All hand torches and inspection lamps and their cable connections, used within the fuelling zone, should be of certified 'flameproof' or 'intrinsically safe' type.
- l) Only authorised persons and vehicles should be permitted within the fuelling zone and the numbers should be kept to a minimum.

2.2.7 **Special Hazards**

- a) Aircraft should not be fuelled within 30 m (100 ft) of radar equipment under test, or in use in aircraft or ground installations.
- b) When any part of an aircraft landing gear, i.e. the wheels, tyres and brakes, appears overheated, the Aerodrome Fire Service should be called and fuelling should not take place until the heat has dissipated (see also Leaflet 32-20).
- c) Extreme caution should be exercised when fuelling during electrical storms. Fuelling should be suspended during severe electrical disturbances in the vicinity of the aerodrome.
- d) The use of photographic flash bulbs and electronic flash equipment within 6 m (20 ft) of the filling or venting points or aircraft or fuelling equipment, should not be permitted.

2.2.8 **Spillage of Fuel**

The actions to be taken in the event of a spillage of fuel will depend on the size and location of the spillage, the type of fuel involved and prevailing weather conditions.

- a) If, despite care, fuel is inadvertently spilled in the aircraft structure, it should be cleared before the main aircraft engines are started. Lowering the flaps may accelerate drainage in some cases. Flight should be delayed to permit the evaporation of spillage and air blowers should be utilised as necessary.
- b) In the case of a minor spillage of fuel on the ground, all liquid should be mopped up and the area allowed to dry out before starting any aircraft or vehicle engines in the vicinity.
- c) In the case of a major spillage of fuel (i.e. covering an area greater than 5 m² (55 ft²)), action should immediately be taken to stop the flow of fuel, to evacuate all persons from the area and to notify the Aerodrome Fire Services.

- d) Fuel should not be washed into drains or culverts, but if such contamination does occur, large-scale water flushing should be carried out and the local water authority notified. Absorbent cleaning agents or emulsion compounds should be used to absorb spilled fuel, the contaminated absorbents being placed in suitable containers and removed to a safe location for disposal. The selection of tools and equipment to be used in removing spilled fuel and disposing of contaminated materials should have regard to minimising the risk of ignition.

2.3 Work in Hangars

- 2.3.1 Before commencing any inspection, overhaul or repair work involving the use of possible ignition sources in the vicinity of the fuel tanks, all tanks should be drained. De-fuelling should be carried out in the open air, by means of a fuel tanker utilising the pressure fuelling/de-fuelling connections on the aircraft, or by draining the tanks into suitable containers. In either case, adequate bonding precautions should be taken, the tanker or containers being bonded to the aircraft and the ground before draining commences. Care should be taken to avoid spilling fuel on to the ground and containers should be sealed immediately after filling. To avoid danger from sparking between containers and ground contacts, the aircraft should normally be moved from the site first.

NOTE: If fuel tests (e.g. calibrations, flows, etc.) or draining become necessary inside hangars, then additional precautions are required. Adequate notices should be displayed and fire-fighting personnel should be in attendance. It should be noted that for calibration checks aircraft are usually on jacks to maintain a known datum and could not, therefore, be towed away in the event of a fire.

- 2.3.2 The draining of fuel tanks does not render them free from fire risk, as they will contain fuel vapour. It is therefore necessary to purge tanks of vapour before subjecting them to inspection or repair involving the use of heat, electrical equipment or other sources of ignition.
- 2.3.3 Special care is necessary during fuel flow testing and foam or CO₂ type extinguishers should always be available whilst this work is in progress. The use of an enclosed flow test rig is recommended (see paragraph 2.3.1 NOTE).
- 2.3.4 Electrical equipment used during maintenance work, e.g. portable lighting equipment, electric drills, soldering irons, etc., should be maintained in good condition to avoid generating sparks and should not be used when flammable vapours are present in the atmosphere. For work in areas where heavy fumes are present, e.g. inside fuel tanks, flameproof torches must be used. Care should be taken that no flammable fluid is splashed on naked bulbs or other hot surfaces as spontaneous ignition may follow. Low voltage electrical supplies for inspection lamps, etc., are advantageous.
- 2.3.5 As far as possible, only non-flammable cleaning fluids and paint strippers should be used, but if the use of solvents giving off flammable vapours is unavoidable, they should be handled with care and if spilt, should be wiped up immediately. During the use of such fluids the aircraft electrical system should be made inoperative with, for preference, the aircraft batteries removed.
- 2.3.6 In certain aircraft, special battery lead stowages are embodied. These should be utilised in accordance with the appropriate instructions contained in the Maintenance Manual.
- 2.3.7 The spraying of large surfaces with dope or paint should be carried out in a properly manufactured and equipped spray shop. When touching up small areas, all electrical apparatus worked from a mains supply should be switched off or removed from the vicinity.

- 2.3.8 Open containers of dirty oil, fuel, dope or solvents should not be stored in aircraft hangars and should be removed from the vicinity of aircraft as soon as possible, otherwise accumulations of flammable vapour may result.
- 2.3.9 Magnesium and titanium swarf should be completely removed after drilling or machining operations. Special dry powder extinguishants, which are usually known by a trade name, should be used on fires of these combustible metals; water must not be used. The extinguishants form a crust or skin over the burning metal and thus exclude air.
- 2.3.10 Before permitting the refitting of floor panels or inspection covers, inspectors should ensure that the bays are clean and free from all foreign matter, that all drains are unobstructed and all applications of primers, sealing compounds, etc., in the boxed up area are dry. In addition, all electrical connections, fuse box covers, etc., should be checked and the systems functioned and if the bay houses part of the flying control system duplicate inspection of the flying controls should be carried out before fitting the covers or panels.

NOTE: Fire precautions specified in the Factories Act and in other governmental or local regulations for industrial premises, should always be strictly observed.

3 Maintenance and Fire Prevention

- 3.1 The following recommendations provide guidance on maintenance practices which will reduce the risk of fires occurring in flight or when ground running engines.

3.2 Powerplant

- 3.2.1 Faulty assembly or mechanical failure of engines or powerplant components can cause fire and careful inspection is therefore essential to ensure that fractures, cracks or leaks are detected and rectified.
- 3.2.2 Attention should be given to main engine and APU starter systems and in particular, to ignition harnesses and to high energy igniter plugs and leads in turbine engines. Maintenance instructions must be carefully carried out in accordance with the engine Maintenance Manual.
- 3.2.3 Pipes carrying flammable fluids are routed by design as far from exhaust systems and electrical apparatus as the installation permits and if disturbed, should be re-installed so that the original distances from such sources of ignition are not reduced. Great care must always be exercised to ensure that pipes are in good condition, are appropriately colour coded and are adequately clipped and bonded and that unions are correctly secured so that leaks cannot occur and that drains are clear. Guidance on the inspection of flexible and rigid pipes is given in Leaflets 20-50 and 20-60 respectively (see also paragraph 3.2.13).
- 3.2.4 It is most important to trace the source of any flammable fluid leakage and to rectify it immediately. Kerosene, lubricating oil, gasoline and most hydraulic fluids will ignite spontaneously if in contact with hot surfaces, such as exhaust pipes, combustion chambers, jet pipes and overheated brakes. Gasoline at ambient temperatures and kerosene at elevated temperatures will vapourise and form a combustible mixture with air, which may be ignited by sparks from electrical equipment or accumulations of static electricity. Fuel and oil drains should be checked for blockage and the routing of the pipes must be clear of cowlings and brake systems. Cowlings should be kept clean to obviate accumulations of flammable fluids, greases and dirt.
- 3.2.5 The flame traps or shutters of air intake systems must always be in good condition. Flame traps will burn if combustible sludge is allowed to accumulate on the gauze.

- 3.2.6 Grommets or flash plates used to seal openings in firewalls must always be refitted carefully and renewed if damaged. Gaps through or around a firewall are not permitted. Seals must be securely fixed in position, approved sealants should be renewed as necessary and distorted or damaged cowlings must be repaired or renewed.
- 3.2.7 The powerplant bonding system is an important safeguard against fire and all bonding connections should be inspected frequently.
- 3.2.8 A major failure, such as the fracture of a cylinder or induction manifold on a piston engine (particularly a supercharged engine) is a serious matter, as air/fuel vapour mixture may be discharged and contact a hot surface in the powerplant area, where ignition could occur. Careful visual examination may reveal minor defects before the danger of a complete breakdown arises.
- 3.2.9 Shortage of coolant in liquid-cooled piston engines will result in overheating with a grave risk of mechanical failure of the engine causing a fire. It follows that careful maintenance of cooling systems is an aid to fire prevention.
- 3.2.10 Cracked exhaust manifolds, pipes, ejectors, or turbine-engine combustion chambers may allow hot gases or torching flame to impinge on vulnerable parts of the powerplant installation, either causing fire directly or giving rise to mechanical failure which may start a fire. Exhaust systems and combustion chambers should therefore receive very careful examination.
- 3.2.11 Engine vibration is generally an indication of a serious defect and can also result in the cracking of pipes or leaking of high pressure hoses and loosening of pipe connections.
- 3.2.12 It is most important that all the appropriate fire precautions are taken during the operation of auxiliary power units whilst the aircraft is on the ground. Intakes and exhausts must be free from obstruction. Temperature and warning indicators should be observed and action taken accordingly.
- 3.2.13 A contributory cause of fires in engine bays is the saturation of flexible-pipe lagging by flammable liquids. This can occur when the outer covering (e.g. sleeving of neoprene or rubber) has been damaged or has deteriorated, allowing seepage into the lagging. This condition can be detected by blistering or a soggy feel, as distinct from the hard feel of unsaturated pipes. If pipes are in a saturated condition they should be renewed.

3.3 **Airframes**

- 3.3.1 Leakage of fuel, hydraulic, de-icing or lubricating fluids, can be a source of fire in aircraft and this should be noted when inspecting aircraft systems. Minute pressure leaks of these fluids may be dangerous, as they could quickly produce an ignitable mixture.
- 3.3.2 Fuel tank installations should always be carefully examined for signs of external leaks. With integral fuel tanks, the external evidence of a leak may occur at some distance from where the fuel is actually escaping, particularly with kerosene which has particular penetrating properties.
- 3.3.3 Hydraulic fluids are generally flammable and should not be allowed to accumulate in the structure. Lagging and sound-proofing materials may be rendered highly flammable if soaked with oil of any kind and should be renewed.
- 3.3.4 All oxygen system equipment must be kept absolutely free from traces of oil, grease or flux, as these substances will ignite spontaneously in contact with pressurised oxygen. Oxygen servicing cylinders should be clearly marked so that they cannot be

mistaken for cylinders containing Air, CO₂ or Nitrogen, as explosions and fatal accidents have resulted from these errors during maintenance operations.

NOTE: When a form of lubricant is necessary (e.g. because of a binding thread) the approved or recommended lubricant must be used. Lubricant should be used sparingly to ensure that it does not enter the oxygen system.

- 3.3.5 Any spillage or leakage of flammable fluid in the vicinity of combustion heaters is a serious fire risk, particularly if any vapour is drawn into the heater and passed over the hot combustion chamber. All safety devices, such as NO-HEAT or OVER-HEAT switches should be inspected at the intervals prescribed in the relevant Maintenance Schedule.
- 3.3.6 Hot air de-icing and other heating systems should be carefully inspected, particularly on turbine-engined aircraft, where high initial air temperatures exist, to ensure that the ducting and lagging are free from defects.
- 3.3.7 Pyrotechnical equipment such as signal cartridges, should be renewed if defective in any way. Stowages should not be located in high temperature zones.

3.4 Passenger Smoking Compartments

In these compartments, furnishing materials must be flame-resisting and approved by the CAA. It is important that any gaps or crevices in the flooring and at the free edges of panelling should be sealed and this should be checked at regular intervals. Furnishing materials should also be inspected for grease or oil stains which may tend to propagate a fire and loose covers which have been laundered or dry-cleaned should be re-proofed as necessary. Ash trays must be fitted and a hand-held fire extinguisher of an approved type must be installed.

NOTE: The use of highly toxic extinguishants such as methyl bromide or carbon tetrachloride is prohibited in either crew or passenger compartments. However, in the case of a fire occurring during servicing or maintenance, the toxicity of the extinguishant may be less important, particularly if it is possible to direct the extinguisher through an open door or window into the fuselage.

3.5 Electrical Equipment

- 3.5.1 As faulty electrical equipment can provide a source of ignition by generating sparks or becoming overheated, attention should be given to the following points:
 - a) Overheating and eventual destruction of cables can be caused by overloading a circuit. To prevent this, particular care should be taken when installing new fuses or cables to ensure that the design standards as shown on the relevant drawings or manuals are maintained.
 - b) Overheating of equipment can be caused by poor ventilation. Gauzes may become choked and cooling ducts damaged or disconnected.
 - c) Electrical sparks from bad commutation in generators or motors and arcing at relays and loose connections, are particularly dangerous. Terminal ends and cover bands must be torque loaded in accordance with the Maintenance Manual and securely locked.

NOTE: There have been cases of short-circuits at terminal positions and special care is necessary to prevent inter-action between circuits at these positions, particularly after any re-orientation of cables and looms. Care is also necessary to prevent arcing and tracking across terminal blocks through the ingress of moisture.

- 3.5.2 Deterioration of cable insulation can be caused by exposure to fluids such as fuel, hydraulic fluid, oil, etc., or their vapours. Heat and sunlight also have deleterious effects and if exposure is severe or continuous the insulation may eventually break

down. Faulty insulation on cables may be the cause of arcing, particularly on heavy duty cables which are attached to movable components or parts, e.g. adjustable lamps, portable apparatus and leads to control columns. Particular care should be taken to ensure that these cables are correctly installed and tested for insulation resistance and freedom from chafing at the prescribed intervals, in accordance with the relevant Maintenance Manual.

- 3.5.3 Bearing failure in engine-driven rotating equipment may result in friction that could generate sufficient heat to destroy the component and create a serious fire risk.

4 Engine Running Precautions

4.1 General

Fires during engine starting and running can be avoided by observing the correct drill given in the relevant Manuals for the aircraft and engine concerned. General guidance on some important points is given in the following paragraphs:

- a) Whilst engines are being started and ground run, fire extinguishing apparatus, preferably of the CO₂ trolley type with extending applicator and under the control of trained and experienced personnel, should be positioned near the aircraft. Additionally, a good communication system should be arranged between the cockpit and ground.
- b) Persons in control of engine ground running should be familiar with the approved ground running instructions in the appropriate Manuals and with the correct fire drill procedure.

4.2 Piston Engines

- 4.2.1 Care should be exercised when priming piston engines preparatory to starting, particularly when an electrical priming pump is used or when priming is carried out by pumping the throttle (to operate the carburettor accelerator pump). Overpriming can cause an excess of fuel in the engine and could result in an intake fire.
- 4.2.2 When excess-fuel conditions exist and an engine fails to start (a common occurrence when engines are hot), the fuel cock should be turned OFF (or the fuel cut-out closed) and the throttle should be fully opened. After ensuring that all ignition switches including booster coil switches are OFF, the engine should be turned. Most types of engines can be turned in the running direction by the propeller or starter. When this has been done, precautions should be taken to dispel any accumulations of fuel in the exhaust system. On some small engines the propeller can be used to turn the engine in the reverse direction of rotation to expel the over-rich fuel-air mixture through the air intake.
- 4.2.3 If an air intake fire occurs before the engine picks up, a previously agreed signal should be made to the person at the controls, who should immediately turn off the appropriate engine fuel cock; it is often recommended to continue to motor the engine on the starter so that the burning fuel is drawn into the engine. If the engine picks up and runs, an air intake fire will probably cease without further action, in which case the fuel may be turned on again. Consideration should then be given to any damage which may have been caused to the intake filters by the intake fire.

4.2.4 If an intake fire persists or appears to be serious, a ground CO₂ type fire extinguisher should be discharged into the air intake. Outside action will also be necessary if burning fuel runs from the intake or exhaust on to the ground.

- NOTES:**
- 1) The ideal fire extinguishants to use are CO₂ or BCF which will cause no harm to the engine. If CO₂ or BCF have been drawn into an engine no harm should result provided the engine is run or turned over adequately within the next few hours. However, if an extinguishant such as methyl bromide is allowed to remain in the engine, particularly at temperatures below 4°C when it is in a liquid state, it will be necessary to strip the engine to ensure that corrosion has not occurred. If foam has been drawn into an engine the danger of corrosion can be greater. Mechanical foams can leave deposits which may be cleared by hot engine running. Chemical foams can leave deposits which require engine stripping.
 - 2) Mechanical foam is an extinguishant formed by mixing air, water and foam-making liquid.

4.2.5 Should an engine fire occur whilst ground running, the drill given in the appropriate Manual should be followed. To help the person in charge of the ground fire-fighting equipment, any other operating engines should be shut down.

4.2.6 Any practice which promotes accumulation of flammable fluid or vapour inside engine cowlings should be avoided. Exhaust systems must give complete sealing; flanges, gaskets and air intake sealing must be regularly examined and maintained. In shutting-down, engines should first be cooled by running at low power for a short period and fuel cut-outs (if fitted) should be used strictly in accordance with the engine manufacturer's operating instructions.

4.3 Gas Turbine Engines

4.3.1 The most frequent cause of fire during starting is the accumulation of fuel in the engine and jet pipe following an earlier 'wet start' (i.e. an unsuccessful attempt to start in which the fuel has failed to ignite and has been distributed throughout the engine and jet pipe and drained into the lower combustion chambers and drain system). It is necessary to ensure that the drain system operates correctly and to drain the vent tank (which has a limited capacity), as advised by the manufacturer. It is normal practice to carry out a 'dry run' (i.e. motor the engine through the starting cycle with the fuel and ignition turned off) after a wet start, before making another attempt to start an engine.

4.3.2 As kerosene spreads readily and does not evaporate quickly, a very slight leak is significant and must be remedied. Fuel which may have collected in cavities, cowlings, etc., should be wiped up after maintenance operations before any attempt is made to start the engines.

4.3.3 If there is any indication of an internal engine fire when an engine is not running, the fuel cocks should immediately be turned OFF and every attempt made to localise the fire. An outside assistant should discharge a CO₂ or BCF extinguisher into the intake or jet pipe if necessary.

4.3.4 When starting and running gas turbines, particular note should be taken of the jet pipe temperature. If this exceeds the manufacturer's limitations, a serious risk of mechanical failure followed by fire may result.

4.3.5 The recommendations of paragraph 4.2.5 apply equally to gas turbine engines.

4.4 **Engine Nacelle Fire Extinguisher Doors**

These engine nacelle doors (British Standard C.6), when fitted, should be maintained strictly in accordance with the aircraft Maintenance Manual. It is important that the doors operate freely inwards and that the beads or lips on the doors will not restrict the removal of the extinguisher nozzle.

Chapter H Maintenance Personnel Licensing

Leaflet H-10 Aircraft Maintenance Engineers Licensing – General Licensing Information

1 General

- 1.1 Information on written examinations including dates, venues and charges can be viewed via the Engineering Examinations link in the Licensing and Training Standards section of the CAA web site (www.caa.co.uk/pld). Other detailed information on licensing is also published in the Licensing and Training Standards area of the web site. This site is updated frequently and engineers preparing to apply for exams or licence issue/extension are strongly advised to view it for current information on policy, procedures or exam schedules. Application forms may also be downloaded from the site.
- 1.2 Additional information relating to Part-66 and the cessation of BCAR Section L has been added to the Engineering Licensing part of the Personnel Licensing web site.
- 1.3 Following the UK CAA introduction of the Part-66 licence, the majority of BCAR Section L licences were required to be converted by 28 September 2008 for all EASA certified aircraft.
- 1.4 Upon conversion of a BCAR licence to a Part-66 licence, where protected rights did not convert to a full Part-66 category or sub-category licence, limitations were applied. Part-66 limitations may be removed by completing the appropriate conversion examinations.
- 1.5 No further applications to extend a Part-66 licence using the “protected rights” process will be accepted after 28 September 2012.

2 EASA Commission Regulation (EC) No. 2042/2003 Including Implementing Rules (IR) Part-66 and Part-147

- 2.1 The European Aviation Safety Agency (EASA) has commenced operations introducing phased changes in respect of the licensing of aircraft maintenance engineers.
- 2.2 The UK CAA issued the first EASA Part-66 licence for aircraft above 5700 kg MTOM on 1 June 2004 and the first EASA Part-66 licence to include aircraft above and below 5700 kg MTOM on 29 November 2004.
- 2.3 Maintenance certification for some aircraft categories e.g. Annex II aircraft and airships will continue for the time being to be regulated by the UK CAA under National Requirements of BCAR Section L. A future Part-66 ELA licence is proposed and required to be in place by 28 September 2015. It is currently proposed that this licence will be required for certification of ELA1 aeroplanes not involved in commercial air transport. It may also be required for gliders, sailplanes, airships and balloons.

NOTE: Annex II and State aircraft are aircraft that are not included under EC Regulation 216/2008 and therefore Part-145 and Part-M do not apply.

3 BCAR Section L Licence Renewal

- 3.1 Applicants may still renew their BCAR Section L licences where a need can be shown, e.g. for Annex II type aircraft ratings or airships.

4 The Engineers Licensing Guidance Document

- 4.1 The latest version of this document and all applicable updates are available on our website www.caa.co.uk/ELGD.
- 4.2 The ELGD was designed to assist Aircraft Maintenance Engineers and those involved with aircraft maintenance engineering by providing guidance on existing Aircraft Maintenance Engineering licensing requirements.

Leaflet H-20 Licensed Aircraft Maintenance Personnel – Certification Responsibilities of Type Rated/Authorised Personnel

- 1 **General** The purpose of this Leaflet is to describe the certification responsibilities of UK Licensed Aircraft Maintenance Personnel. Such personnel may be the holder of an Aircraft Maintenance Engineer's Licence issued under BCAR Section L or an Aircraft Maintenance Licence issued under Part-66. The responsibilities apply when issuing certifications either as a Type Rated Licence holder or as an engineer holding a certification authorisation. It also describes the privileges of the various Type Rated Licences.

It should be noted that where the holder of a licence is performing maintenance activities on an aircraft on which he or she is not appropriately licensed, i.e. acting as a non-certifying engineer, they are still expected to act responsibly and carry out such work in accordance with the procedures and standards identified in the following paragraphs.

A National licence issued by the United Kingdom CAA does not confer any certification privileges with respect to aircraft which are not registered in the United Kingdom unless the licence holder is entitled to certify for such activities by way of having the licence validated by the relevant Airworthiness Authority and/or is authorised by a maintenance organisation approved by that Authority.

NOTES: 1) A BCAR Section L Licence Without Type Rating or a Part-66 Aircraft Maintenance Licence does not confer any certification privileges on the holder in their own right (except for that allowed under Part M.A.801(b)2). Such licences must be used in conjunction with a certification authorisation.

2) In the context of this Leaflet, reference to an authorisation means an authorisation issued by an EASA or a CAA Approved Maintenance Organisation (under the requirements of BCARs or Part-145 or Part-M) to allow the holder to issue certifications within the limitations shown on the authorisation.

3) As of 28 September 2008 certification of maintenance on non-commercial transport aircraft using a Part-66 licence as authority is limited to items which are not included in the list at Part-M Appendix VII.

- 1.1 a) The Certificate referred to under articles 25 and 26 of the Air Navigation Order 2009 (as amended) is a Certificate of Maintenance Review to be issued following completion of the review required by the Order. The Certificate referred to under articles 28, 29, 30 and 31 of the Air Navigation Order 2009 (as amended) is a Certificate of Release to Service to be issued on completion of maintenance of aircraft or components not required to be maintained under Part-145 or Part-M.
- b) The Certificate referred to in Part-145, paragraph 145.A.50 is a Certificate of Release to Service to be issued on completion of maintenance of aircraft or components which are required to be maintained under the provisions of Part-145.
- c) The certificate referred to in Part-M.A.801 is a Certificate of Release to Service to be issued on completion of maintenance of aircraft or components which are required to be maintained under the provisions of Part-M.
- 1.2 In connection with the issue of Certificates of Release to Service, the following definitions apply:

- a) **Maintenance** means any one or combination of overhaul, repair, inspection, replacement, modification or defect rectification of an aircraft/aircraft component. Regulation (EC) No. 2042/2003 extends this definition to include 'with the exception of pre-flight inspection'.
- b) **Overhaul** means the restoration of an aircraft/aircraft component by inspection and replacement in conformity with an approved standard to extend the operational life.
- c) **Repair** means the restoration of an aircraft/aircraft component to a serviceable condition in conformity with an approved standard.
- d) **Inspection** means the examination of an aircraft/aircraft component to establish conformity with an approved specification.
- e) **Replacement** is any work operation which involves the removal and replacement of the same part or the substitution of an approved alternative part.
- f) **Modification** means the alteration of an aircraft/aircraft component in conformity with an approved standard.

NOTES: 1) Defect rectification normally consists of an element of inspection and troubleshooting followed by repair and replacement of the defective item.

2) Inspection includes:

- i) Mandatory Inspection, an inspection made Mandatory by EASA, where the inspection itself is the work (see CAP 747).
- ii) Scheduled Maintenance Inspection, an inspection or maintenance including tests required by the Approved Maintenance Schedule or Programme.

1.3 Although many terms in common usage describe the various aspects of aircraft engineering, the meanings assigned to such terms are not always the same. For the purpose of this Leaflet, in relation to airworthiness, the following definitions apply:

- a) **Condition** – the physical state of an item.
- b) **Assembly** – that items are fitted, assembled, attached, installed, connected, secured or adjusted in the approved manner.
- c) **Functioning** – operation in the approved manner achieving such performance, range of movement and freedom of movement as may be specified.

The certifying engineer shall be responsible for the condition, assembly and functioning of the aircraft or its components for maintenance that has been certified under the privileges of a Type Rated Licence or an authorisation.

1.4 The certifying engineer shall be responsible for ensuring that work is performed and recorded in a satisfactory manner taking into account the following:

- a) Whenever work is carried out on an aircraft, it is the duty of all persons to whom this Leaflet applies to ensure that the work, for which they are responsible, progresses in a managed and controlled manner. Where they are supported by additional staff to carry out the work, consideration shall be given by them before starting the work to the manpower resource available and the abilities of the staff concerned. This is to ensure that the certifying engineer determines and exercises an adequate degree of supervision over such staff.
- b) In relation to work carried out on an aircraft, it is the duty of all persons to whom this Leaflet applies to ensure that an adequate record of the work carried out is maintained. This is particularly important where such work carries on beyond a working period or shift, or is handed over from one person to another. The work

accomplished, particularly if only disassembly or disturbance of components or aircraft systems, should be recorded as the work progresses or prior to undertaking a disassociated task. In any event, records should be completed no later than the end of the work period or shift of the individual undertaking the work. Such records should include open entries to reflect the remaining actions necessary to restore the aircraft to a serviceable condition prior to release. In the case of complex tasks which are undertaken frequently, consideration should be given to the use of pre-planned stage sheets to assist in the control, management and recording of these tasks. Where such sheets are used, care must be taken to ensure that they accurately reflect the current requirements and recommendations of the manufacturer and that all key stages, inspections, or replacements are recorded.

- c) It is also the duty of all persons to whom this Leaflet applies to consider the effect such work may have, directly or indirectly, on items which are the responsibility of other such persons. In all cases where an overlap of responsibility between licence categories occurs, the person primarily responsible for the item must involve all other trade disciplines affected. Every person to whom this Leaflet applies must therefore be conversant with all other relevant paragraphs of this Leaflet. Certificates of Release to Service for each relevant trade category must be issued by all persons concerned, each assuming responsibility of and certifying those aspects of the work for which the licence/authorisation holder is entitled to assume responsibility.

1.5 A Certificate of Release to Service shall only be issued on completion of maintenance when the signatory is (signatories are) satisfied that the work has been properly carried out and accurately recorded, having due regard to the use of:

- a) up-to-date instructions and maintenance data (including manuals, drawings, specifications, EASA Airworthiness Directives and Mandatory Requirements listed in CAP 747, and, where applicable, company procedures);
- b) recommended tooling and test equipment which is currently calibrated where applicable;
- c) a working environment appropriate to the work being carried out.

When issuing a Certificate of Release to Service for work performed by others, the certifying engineer assumes responsibility. The certifying engineer must have inspected a sufficiently representative sample of the work and the associated documentation, and be satisfied with the competence of the persons who have performed the work. For complex tasks this may require progressive inspections to be carried out as the work proceeds. In the case of an aircraft or component where welding a metallic part is considered essential to airworthiness, it is the responsibility of the certifying engineer to establish that the welder is approved in accordance with the requirements in BCAR Section A sub-section A8 for aircraft maintained under national requirements.

For aircraft maintained under Part-M Subpart F or Part-145 it is the responsibility of the organisation to establish and control competencies in accordance with EC Regulation 2042/2003.

NOTE: Licensed engineers certifying under the privileges of their licence may not deviate from the manufacturer's maintenance instruction or maintenance data, nor use alternative parts, components or assemblies unless such deviation is supported by the written agreement of the manufacturer, approved as a change or agreed by the CAA. The local CAA Regional Office should be consulted in cases of difficulty. Authorised engineers shall comply with all company procedures covering such issues.

- 1.6
- a) When the work involves the assembly or any disturbance of a vital point defined in BCAR Section A, Chapter A5-3 or control system, the duplicate inspection required must be completed and certified in accordance with BCAR Section A/B Chapter A/B6-2 before the relevant Certificate of Release to Service is issued.
 - b) Part-M.A.402(a) requires that an independent inspection shall be carried out after any flight safety sensitive maintenance task unless otherwise specified by Part-145 or agreed by the competent authority.
 - c) The holder of a Type Rated Licence in Category 'A' and/or 'C' or Part-66 Category B1 may make certification on aircraft (or their engines, as appropriate) below 5700 kg MTOM for Duplicate Inspections of minor adjustments to control systems on other types within the Category in which the licence is type rated.
- NOTE:** A minor adjustment is considered to be a single point adjustment or reassembly of a control.
- 1.7
- The holder of an appropriately Type Rated BCAR Section L Aircraft Maintenance Engineer's Licence in Categories 'A', 'B', 'C' or 'D', or the holder of an aircraft Type Authorisation equivalent to Section L Categories 'A' and/or 'C' or Part-66 Category B1, may issue a Certificate of Release to Service to cover Non Destructive Inspections on aircraft or components, within the privileges of the licence or authorisation held, subject to the work being carried out as follows:
- a) Inspection requiring the use of Field Kit for the Colour Contrast Dye Penetrant technique may be carried out by persons either Type Rated or Type Authorised as above or persons qualified in accordance with Generic Requirement (GR) No. 23 in CAP 747.
 - b) Non Destructive Inspections requiring any other technique, including Fluorescent Penetrant Dye, shall be carried out and signed for by persons appropriately qualified in accordance with Generic Requirement (GR) No. 23 in CAP 747 prior to the issue of the CRS by a licensed or authorised engineer.
- 1.8
- Use of either a Type Rated Licence or an authorisation to issue a certification requires that, in addition to the Licence or Authorisation being valid at the time of certification, the holder has been engaged for periods totalling at least 6 months during the 24 months preceding the date of the certification on work affording experience comparable with that required for the grant of the Licence/Authorisation.
- 1.9
- A Type Rated Licensed Engineer may issue the Certificates identified below in relation to aircraft for which the licence is Type Rated and in accordance with the privileges detailed in the remaining paragraphs to this Leaflet. An authorised engineer may only issue these certificates as permitted within the limits of the authorisation.
- a) Certificate of Release to Service for aircraft not required to be maintained under Part-M Subpart F or Part-145 – the holder of an appropriately Type Rated Licence may issue Certificates of Release to Service subject to compliance with the requirements of BCAR Section A/B, Chapter A/B6-2 and A/B6-7.
 - b) Certificate of Maintenance Review – the holder of an appropriately Type Rated Licence in at least two Categories (other than Category 'X' Compasses) may issue a Certificate of Maintenance Review subject to compliance with the requirements of BCAR Section A/B, Chapter A/B6-2 and A/B6-7 and the Maintenance Schedule Approval Document.
 - c) Certificates of Fitness for Flight – the holder of an appropriately Type Rated Licence may issue Certificates of Fitness for Flight subject to compliance with the requirements of BCAR Section A/B, Chapter A/B3-8.

d) Flight Release certificate - for aircraft not required to be maintained under Part-145. The holder of a valid and appropriately type rated aircraft maintenance engineer's licence granted under BCAR Section L or the holder of a Part-66 licence appropriately endorsed for the aircraft type rendered valid in the United Kingdom, may issue a Flight Release certificate under the terms of an EASA Permit to Fly.

1.10 The following licence categories may be used to allow the grant of an authorisation within a Maintenance Organisation approved in accordance with CAA requirements:

- A BCAR Section L LWTR (Licence Without Type Rating) providing that the authorisation issued is within the scope of the licence held at 1st June 2001. Applicable to aircraft of MTOM less than 5700 kg only.
- A BCAR Section L LWTR extended with the appropriate Type Rating. Applicable to aircraft of MTOM less than 5700 kg only.
- A Part-66 Category A licence providing that the authorisation issued is in compliance with AMC 145.A.30(g).
- A Part-66 Category B licence providing that the licence has been extended with the appropriate type rating. No authorisation permitted against the basic Part-66 licence.
- A Part-66 Category C licence providing that the licence has been extended with the appropriate type rating. No authorisation permitted against the basic Part-66 licence.

In addition to the foregoing paragraphs, when working within such Organisations, the licensed engineer should be aware that he/she is part of a comprehensive maintenance system. It is therefore important to realise that company procedures may further define, or require specific actions, as to how certain issues are to be dealt with and these procedures must be adhered to. It is also important to realise that when working within an approved Maintenance Organisation and certifying under the privileges of an authorisation the licensed engineer is not certifying under the privileges of the licence.

NOTES: 1) UK licence holders may work for and therefore be authorised to certify by Maintenance Organisations which are not CAA approved. In such cases, validation of a UK issued BCAR Section L licence or Part-66 licence may be required. In addition, the holder of a licence may be required to satisfy specific company requirements for authorisation. Such requirements may also introduce additional National legislation and working practices which the licence holder should note and comply with. Whilst certifying under such authorisations and in the absence of specific guidance the principles and practices promulgated in this Leaflet should be adhered to.

2) A Part-66 licence is required for all Part-M Subpart F or Part-145 authorisations issued by the approved maintenance organisation.

2 BCAR Section L Aircraft Maintenance Engineer's Licence – Type Rated in Category 'A' – Aeroplanes

2.1 The holder of a BCAR Section L Category 'A' licence may issue Certificates of Release to Service in respect of maintenance in relation to non-commercial air transport aeroplanes, which fall under the definition of EC Regulation 216/2008 Annex II (but not including engines) for which the licence is Type Rated.

- 2.2 In connection with the certification of maintenance the holder of a Type Rated Licence in Category 'A' is responsible for all parts of the aeroplane subject to the limitations detailed below (excluding those parts which are the responsibility of the holder of a Type Rated Licence in Category 'C').
- 2.3 The holder of a Type Rated Licence in Category 'A' may issue Certificates of Release to Service relating to maintenance (excluding overhaul) of parts of the aeroplane for which the holder is responsible, providing that the work has not involved any of the following:
- a) Bolted joints requiring special techniques;
 - b) Complete riveted joints in primary structures;
 - c) Complete glued joints in primary structures;
 - d) Bonded assemblies in primary structures;
 - e) Composite material primary structures;
 - f) Welded and brazed joints, other than minor weld repairs carried out by an Approved Welder, but excluding replacement of structural members or repairs to flying control components;
 - g) Cotton, linen, polyester and glass fibre fabric covering of a complete fuselage or aerofoil;
 - h) The disturbing of individual parts of units which are supplied as bench tested units, except for the replacement or adjustment of items normally replaceable or adjustable in service.
- 2.4 In connection with the maintenance of instrument, electrical, automatic pilot and radio systems installed in aeroplanes (excluding overhaul or such systems as are associated with the engine(s) and auxiliary power unit(s)) the holder of a Type Rated Licence in Category 'A' is entitled to issue Certificates of Release to Service for aircraft for which he holds a Type Rating, subject to the limitations detailed in sub-paragraphs 2.4.1, 2.4.2, 2.4.3, 2.4.4 and 2.4.5.
- NOTE:** Where no limitations are shown, Certificates of Release to Service may be issued for repair, replacement, modification, mandatory inspection or scheduled maintenance inspection. In respect of the certification of scheduled maintenance inspections, reference should also be made to the Maintenance Schedule Approval Document which may require certification specifically by an engineer licensed in the appropriate 'X' or 'R' Category. However, in the absence of such a requirement, the holder of a Type Rated Licence in Category 'A' Aeroplanes assumes the responsibility for establishing compliance with the maintenance schedule requirements on the systems before issuing the Certificate of Release to Service.
- 2.4.1 In respect of instrument systems in the aeroplane (excluding instrument systems associated with the engine(s) and auxiliary power unit(s)):
- a) If the aeroplane has an instrument system specified in sub-paragraph 8.1 of CAP 562 Leaflet H-30, Certificates of Release to Service may be issued.
 - b) If the aeroplane has an instrument system specified in sub-paragraphs 8.2 to 8.4 inclusive of CAP 562 Leaflet H-30, Certificates of Release to Service may be issued relating to replacements only, provided that functioning checks to prove serviceability do not require the use of test apparatus.
- 2.4.2 In respect of electrical systems in the aeroplane (excluding electrical systems associated with the engine(s) and auxiliary power unit(s)):

- a) If the aeroplane has an electrical system specified in sub-paragraph 9.1 of CAP 562 Leaflet H-30, Certificates of Release to Service may be issued.
 - b) If the aeroplane has an electrical system specified in sub-paragraphs 9.2 to 9.4 inclusive of CAP 562 Leaflet H-30, Certificates of Release to Service may be issued relating to replacements only, provided that functioning checks to prove serviceability do not require the use of test apparatus.
- 2.4.3 In respect of automatic pilot systems in the aeroplane:
- a) If the aeroplane has an automatic pilot system specified in sub-paragraph 13.1 of CAP 562 Leaflet H-30 installed, Certificates of Release to Service may be issued.
 - b) If the aeroplane has an automatic pilot system specified in sub-paragraph 13.2 of CAP 562 Leaflet H-30 installed, Certificates of Release to Service may be issued relating to replacements only, provided that functioning checks to prove serviceability do not require the use of test apparatus.
- 2.4.4 Certificates of Release to Service may not be issued in respect of radio systems, except that if the aeroplane has a MTOM not exceeding 2730 kg, certificates may be issued in respect of the replacement of VHF communication equipment only.
- 2.4.5 Certificates of Release to Service may not be issued in respect of compass compensation and adjustment unless the licence is endorsed to that effect.

3 BCAR Section L Aircraft Maintenance Engineer's Licence – Type Rated in Category 'B' – Aeroplanes or Rotorcraft

NOTE: This paragraph must be read in conjunction with paragraph 1 of this Leaflet.

- 3.1 The holder of a Section L Category 'B' licence may issue Certificates of Release to Service in respect of overhaul, repair, replacement, modification and mandatory inspection in relation to non-commercial air transport aeroplanes or rotorcraft (but not including engines) for which the licence is Type Rated, subject to the limitations of sub-paragraphs 3.2 and 3.3.
- 3.2 **Category 'B' – Aeroplanes**
- 3.2.1 In connection with the certification of overhaul, repair, replacement, modification and mandatory inspection, the holder of a Type Rated Licence in Category 'B' – Aeroplanes is responsible for all parts of the aeroplane (provided that the work does not involve the manufacturing of components or parts) excluding those parts which are the responsibility of the holder of a Type Rated Licence in Category 'C' or 'D' and subject to the same limitations as detailed in sub-paragraph 2.4 for Category 'A' and excluding the overhaul of electrical, instrument or automatic pilot systems.
- 3.2.2 Notwithstanding the above, the holder of a Type Rated Licence in Category 'B' may also issue Certificates of Release to Service relating to all aspects of overhaul, repair, replacement, modification and mandatory inspection relating to items listed as a) to e) below, except for those parts which form part of or are attached to the engine, provided that the work does not involve the making of components or parts.
- a) Engine mounting structures and cowlings;
 - b) Engine controls;
 - c) Engine fuel, oil and coolant systems;
 - d) Engine fire extinguishing systems;
 - e) Engine fluid de-icing systems.

3.3 **Category 'B' – Rotorcraft**

- 3.3.1 In connection with the certification of overhaul, repair, replacement, modification and mandatory inspection the holder of a Type Rated Licence in Category 'B' – Rotorcraft is responsible for all parts of the rotorcraft (provided that the work does not involve the making of components or parts) excluding those parts which are the responsibility of the holder of a Type Rated Licence in Category 'D' and subject to the same limitations as detailed in sub-paragraph 6.5 for Category 'A' and 'C' Rotorcraft excluding the overhaul of electrical, instrument, automatic pilot systems, main and tail rotor blades.

4 **BCAR Section L Aircraft Maintenance Engineer's Licence – Type Rated in Category 'C' – Engines**

NOTE: This paragraph must be read in conjunction with paragraph 1 of this Leaflet.

- 4.1 The holder of a Section L Category 'C' licence may issue Certificates of Release to Service in respect of maintenance in relation to non-commercial air transport engines and auxiliary power units for which the licence is Type Rated.
- 4.2 In connection with the certification of maintenance (excluding overhaul) the holder of a Type Rated Licence in Category 'C' is responsible for all parts of the engine(s), the engine installation(s), auxiliary power unit(s), other propulsive device(s) and all associated systems and devices which are concerned with their operation, subject to the limitations detailed in sub-paragraphs 4.3, 4.4, 4.5 and 4.6 (excluding those parts which are the responsibility of the holder of a Type Rated Licence in Category 'D').
- 4.3 The holder of a Type Rated Licence in Category 'C' may issue Certificates of Release to Service relating to maintenance (excluding overhaul) of components or parts for which the holder is responsible, providing that the work has not involved:
- Dismantling of a piston engine other than to obtain access to the piston/cylinder assemblies or the removal of the engine rear accessory cover to inspect and/or replace oil pump assemblies where such work does not involve the removal and refitment of internal gears;
 - Dismantling of main casings or main rotating assemblies of a turbine engine, except as detailed in sub-paragraph 4.4;
 - The removal or dismantling of reduction gears, except that, in the case of the BS (DH) Gipsy Queen 70 engine, reduction gears may be removed for the purpose of carrying out inspections after suspected shock loadings;
 - Propeller balancing, except for the certification of static balancing where required by the maintenance manual and dynamic balancing on installed propellers using electronic balancing equipment where permitted by the maintenance manual or other approved airworthiness data. The work itself may have been carried out by an LAE who has received suitable training on the balancing equipment to be used and the associated procedures, or by an organisation approved for that purpose and which has issued an Approved Test Certificate for the inspection;
 - Welded and brazed joints, other than minor weld repairs to exhaust units carried out by an Approved Welder but excluding component replacement;
 - The disturbing of individual parts of units which are supplied as bench tested units, except for the replacement or adjustment of items normally replaceable or adjustable in service.

- 4.4 Where the maintenance manual for the particular engine provides instruction for the task, replacement of main casings and/or rotating assemblies comprising the whole or part of a particular rotating system will be permitted provided that removal from the engine is achieved solely by disconnecting the flanges of main casings. In accordance with the above principles, some engines have been assigned the following symbols, ⊙ or ▲ in CAP 562 Leaflet H-30. Dismantling of these engines is permissible, but is limited to:
- ⊙ – Removal/replacement of main casings, **excluding** those whose removal results in concurrent removal of a rotating assembly from the engine. No dismantling of main rotating assemblies is permitted.
 - ▲ – Removal/replacement of main casings **including** those whose removal results in concurrent removal of a rotating assembly from the engine, **provided this is accomplished solely by disconnecting at the casing flanges**. No dismantling of main rotating assemblies is permitted.
- 4.5 In connection with the maintenance of instrument, electrical and automatic pilot systems installed in aeroplanes, the holder of a Type Rated Licence in Category 'C' is entitled to issue Certificates of Release to Service in respect of such systems associated with engine and auxiliary power unit installations for which the holder has a Type Rating, subject to the limitations detailed in sub-paragraphs 4.5.1, 4.5.2 and 4.5.3.
- NOTE:** Where no limitations are shown, Certificates of Release to Service may be issued for replacement, modification, repair, mandatory inspection or scheduled maintenance inspection. In respect of the certification of scheduled maintenance inspections reference should also be made to the Maintenance Schedule Approval Document which may require certification specifically by an engineer licensed in the appropriate 'X' Category. However, in the absence of such a requirement, the holder of a Type Rated Licence in Category 'C' – Engines assumes the responsibility for establishing compliance with the maintenance schedule requirements on the systems before issuing the Certificate of Release to Service.
- 4.5.1 In respect of instrument systems associated with the engine(s) and auxiliary power unit(s):
- If the engine is installed in an aeroplane which has an instrument system specified in sub-paragraph 8.1 of CAP 562 Leaflet H-30, Certificates of Release to Service may be issued.
 - If the engine is installed in an aeroplane which has an instrument system specified in sub-paragraphs 8.2 to 8.4 inclusive of CAP 562 Leaflet H-30, Certificates of Release to Service may be issued relating to replacements only, provided that functioning checks to prove serviceability do not require the use of test apparatus.
 - If the engine is installed in an aeroplane specified in paragraph 10 of CAP 562 Leaflet H-30, Certificates of Release to Service may not be issued.
- 4.5.2 In respect of electrical systems associated with the engine(s) and auxiliary power unit(s):
- If the engine is installed in an aeroplane which has an electrical system specified in sub-paragraph 9.1 of CAP 562 Leaflet H-30, Certificates of Release to Service may be issued.
 - If the engine is installed in an aeroplane which has an electrical system specified in sub-paragraphs 9.2 to 9.4 inclusive of CAP 562 Leaflet H-30, Certificates of Release to Service may be issued relating to replacements only, provided that functioning checks to prove serviceability do not require the use of test apparatus.

- c) If the engine is installed in an aeroplane specified in paragraph 10 of CAP 562 Leaflet H-30, Certificates of Release to Service may not be issued.

4.5.3 In respect of automatic pilot systems associated with the engine(s):

- a) If the aeroplane has an automatic pilot system specified in sub-paragraph 13.1 of CAP 562 Leaflet H-30 installed, Certificates of Release to Service may be issued.
- b) If the aeroplane has an automatic pilot system specified in sub-paragraph 13.2 of CAP 562 Leaflet H-30 installed, Certificates of Release to Service may be issued relating to replacements only, provided that functioning checks to prove serviceability do not require the use of test apparatus.
- c) If the aeroplane has an automatic pilot system as specified in sub-paragraph 13.3 or is specified in paragraph 10 of CAP 562 Leaflet 15-3, Certificates of Release to Service may not be issued.

5 BCAR Section L Aircraft Maintenance Engineer's Licence – Type Rated in Category 'D' – Engines

NOTE: This paragraph must be read in conjunction with paragraph 1 of this Leaflet.

- 5.1 The holder of a Section L Category 'D' Licence may issue Certificates of Release to Service in respect of non-commercial air transport engines for which the Licence is Type Rated in respect of overhaul, repairs, replacements, modification and mandatory inspection, subject to the limitations of sub-paragraphs 5.2 and 5.3.
- 5.2 In connection with overhaul, repair, replacement, modification and mandatory inspection, the holder of a Type Rated Licence in Category 'D' is responsible for all parts of the engine including functioning only insofar as test bed performance is concerned. The certification of functioning insofar as an installed engine is concerned must be made in conjunction with a holder of a Type Rated Licence in Category 'C'.
- 5.3 The holder of a Category 'D' Licence may issue Certificates of Release to Service relating to all aspects of overhaul, repair, replacement, modification and mandatory inspection of components and parts of the engine only (excluding overhaul, repair, replacement, modification and mandatory inspection of ignition apparatus, instrument equipment and electrical equipment) provided that the work does not involve the making of components or parts.

Commission Regulation (EC) 2042/2003 does not provide provision for aircraft overhaul licences therefore; BCAR Section L category B and D licences do not transfer to a Part-66 category B1 AML. The UK CAA is currently considering the continuance and issue of National overhaul licences for certification purposes on Commission Regulation (EC) 216/2008 Annex II aircraft types.

Although still under consideration, it is likely that **new** applicants for a National licence for airframe overhaul work (BCAR Section L category B) will initially be required to meet the criteria for a Part-66 AML.

6 BCAR Section L Aircraft Maintenance Engineer's Licence – Type Rated in Categories 'A' and 'C' – Rotorcraft

NOTES: 1) This paragraph must be read in conjunction with paragraph 1 of this Leaflet.

- 2) A Category 'A' and 'C' Rotorcraft Licence may not be used to certify for piston or jet turbine engines installed in aeroplanes.

- 6.1 The holder of a Section L Categories 'A' and 'C' Rotorcraft Licence may issue Certificates of Release to Service in respect of maintenance in relation to non-commercial air transport rotorcraft and its engines for which the licence is Type Rated.
- 6.2 In connection with the certification of maintenance the holder of a Type Rated Licence in Categories 'A' and 'C' Rotorcraft is responsible for all parts of the rotorcraft subject to the limitations detailed in sub-paragraphs 6.3, 6.4 and 6.5.
- 6.3 The holder of a Type Rated Licence in Category 'A' and 'C' Rotorcraft may issue Certificates of Release to Service relating to maintenance (excluding overhaul) of parts of the rotorcraft for which the holder is responsible, providing that the work has not involved any of the following:
- a) Bolted joints requiring special techniques;
 - b) Complete riveted joints in primary structures;
 - c) Complete glued joints in primary structures;
 - d) Bonded assemblies in primary structures;
 - e) Composite material primary structures;
 - f) Welded and brazed joints, other than minor weld repairs to aircraft structure or exhaust units carried out by an Approved Welder but excluding structural or component replacement;
 - g) Dismantling of a piston engine other than to obtain access to the piston/cylinder assemblies or the removal of the engine rear accessory case cover to inspect and/or replace oil pump assemblies where such work does not involve the removal and refitment of internal gears;
 - h) Dismantling of main casings or main rotating assemblies of a turbine engine, except as detailed in sub-paragraph 6.4;
 - i) Dismantling of gearbox casings, except that separation of casings to obtain access for the purposes of internal inspections in accordance with the manufacturer's instruction is permitted;
 - j) The disturbing of individual parts of units which are supplied as bench tested units, except for the replacement or adjustment of items normally replaceable or adjustable in service.
- 6.4 Where the maintenance manual for the particular engine provides instruction for the task, replacement of main casings and/or rotating assemblies comprising the whole or part of a particular rotating system will be permitted provided that removal from the engine is achieved solely by disconnecting the flanges of main casings. In accordance with the above principles, some engines have been assigned the following symbols, ⊙ or ▲ in CAP 562 Leaflet H-30. Dismantling of these engines is permissible, but is limited to:
- a) ⊙ – Removal/replacement of main casings, **excluding** those whose removal results in concurrent removal of a rotating assembly from the engine. No dismantling of main rotating assemblies is permitted.
 - b) ▲ – Removal/replacement of main casings **including** those whose removal results in concurrent removal of a rotating assembly from the engine, **provided this is accomplished solely by disconnecting at the casing flanges**. No dismantling of main rotating assemblies is permitted.

- 6.5 In connection with the maintenance of instrument, electrical, automatic pilot and radio systems installed in rotorcraft (excluding overhaul) the holder of a Type Rated Licence in Categories 'A' and 'C' Rotorcraft is entitled to issue Certificates of Release to Service for rotorcraft for which he holds a Type Rating, subject to the limitations detailed in sub-paragraphs 6.5.1, 6.5.2, 6.5.3 and 6.5.4.
- NOTE:** Where no limitations are shown, Certificates of Release to Service may be issued for replacement, modification, repair, mandatory inspection or scheduled maintenance inspection. In respect of the certification of scheduled maintenance inspections, reference should also be made to the Maintenance Schedule Approval Document which may require certification specifically by an engineer licensed in the appropriate 'X' or 'R' Category. However, in the absence of such a requirement, the holder of a Type Rated Licence in Categories 'A' and 'C' Rotorcraft assumes the responsibility for establishing compliance with the maintenance schedule requirements on the systems before issuing the Certificate of Release to Service.
- 6.5.1 In respect of instrument systems in the rotorcraft if the rotorcraft is specified in sub-paragraph 7.4 of CAP 562 Leaflet H-30, Certificates of Release to Service may be issued relating to replacements only, provided that functioning checks to prove serviceability do not require the use of test apparatus.
- 6.5.2 In respect of electrical systems in the rotorcraft, if the rotorcraft is specified in sub-paragraph 7.4 of CAP 562 Leaflet H-30, Certificates of Release to Service may be issued relating to replacements only, provided that functioning checks to prove serviceability do not require the use of test apparatus.
- 6.5.3 In respect of automatic pilot/automatic stabiliser systems in rotorcraft, if the rotorcraft has an automatic pilot/automatic stabiliser system specified in sub-paragraph 13.4 or 13.5 of CAP 562 Leaflet H-30 installed, Certificates of Release to Service may be issued relating to replacements only, provided that functioning checks to prove serviceability do not require the use of test apparatus.
- 6.5.4 Certificates of Release to Service may not be issued in respect of radio systems, except that if the rotorcraft has a MTOM not exceeding 2730 kg, certificates may be issued in respect of the replacement of VHF communication equipment only.

7 BCAR Section L Aircraft Maintenance Engineer's Licence – Type Rated in Category 'X' – Instruments

- NOTE:** This paragraph must be read in conjunction with paragraph 1 of this Leaflet and particular attention paid to sub-paragraphs 1.3, 1.4, 1.5 and 1.6 which are concerned with areas of responsibility.
- 7.1 The holder of a Section L Category 'X' – Instruments Licence may issue Certificates of Release to Service in respect of maintenance in relation to non-commercial air transport aircraft instrument systems for which the licence is Type Rated, subject to the limitations detailed in sub-paragraph 7.3.
- 7.2 In connection with the certification of maintenance, excluding overhaul, the holder of a Type Rated Licence in Category 'X' – Instruments is responsible for all parts of instrument systems included in the Type Rating.
- 7.3 The holder of a Type Rated Licence in Category 'X' – Instruments may issue Certificates of Release to Service in respect of maintenance, excluding overhaul, of components and parts for which the holder is responsible provided that units which are supplied as bench tested units may not have their individual parts disturbed, except for the replacement or adjustment of items normally replaceable or adjustable in service.

8 BCAR Section L Aircraft Maintenance Engineer's Licence – Type Rated in Category 'X' – Electrical

NOTE: This paragraph must be read in conjunction with paragraph 1 of this Leaflet.

- 8.1 The holder of a Section L Category 'X' – Electrical Licence may issue Certificates of Release to Service in respect of maintenance in relation to non-commercial air transport aircraft electrical systems for which the licence is Type Rated, subject to the limitations detailed in sub-paragraph 8.3.
- 8.2 In connection with the certification of maintenance, excluding overhaul, the holder of a Type Rated Licence in Category 'X' – Electrical is responsible for all parts of electrical systems included in the Type Rating.
- 8.3 The holder of a Type Rated Licence in Category 'X' – Electrical may issue Certificates of Release to Service in respect of maintenance, excluding overhaul, of components and parts for which the holder is responsible provided that units which are supplied as bench tested units may not have their individual parts disturbed, except for the replacement or adjustment of items normally replaceable or adjustable in service.

9 BCAR Section L Aircraft Maintenance Engineer's Licence – Type Rated in Category 'X' – Automatic Pilots

NOTES: 1) This paragraph must be read in conjunction with paragraph 1 of this Leaflet.

2) For the purpose of certification, automatic stabilisation systems are deemed to be automatic pilots.

2) Automatic pilots include related systems such as yaw and or roll dampers, mach trim systems, and automatic throttles.

- 9.1 The holder of a Section L Category 'X' – Automatic Pilots Licence may issue Certificates of Release to Service in respect of maintenance in relation to non-commercial air transport aircraft automatic pilot systems for which the licence is Type Rated, subject to the limitations detailed in sub-paragraph 9.3.
- 9.2 In connection with the certification of maintenance, excluding overhaul, the holder of a Type Rated Licence in Category 'X' – Automatic Pilots is responsible for all parts of the automatic pilot systems included in the Type Rating.
- 9.3 The holder of a Type Rated Licence in Category 'X' – Automatic Pilots may issue Certificates of Release to Service in respect of maintenance, excluding overhaul, of components and parts for which the holder is responsible provided that units which are supplied as bench tested units may not have their individual parts disturbed, except for the replacement or adjustment of items normally replaceable or adjustable in service.

10 BCAR Section L Aircraft Maintenance Engineer's Licence – Type Rated in Combined Categories 'X' – Instrument/Automatic Pilots

The Type Rated Licence in Combined Categories 'X' – Instrument/Automatic pilots is comprised of two 'X' Category ratings and the provisions and limitations contained in both paragraphs 7 and 9 of this Leaflet apply in relation to the Instrument and Automatic Pilot systems installed in any aircraft for which the Combined Categories 'X' Licence is type rated.

11 BCAR Section L Aircraft Maintenance Engineer's Licence – Type Rated in Category 'R' – Radio

NOTE: This paragraph must be read in conjunction with paragraph 1 of this Leaflet.

- 11.1 The holder of a Section L Category 'R' – Radio Licence may issue Certificates of Release to Service in respect of maintenance in relation to non-commercial air transport aircraft radio systems for which the licence is Type Rated, subject to the limitations detailed in sub-paragraph 11.3.
- 11.2 In connection with the certification of maintenance, excluding overhaul, the holder of a Type Rated Licence in Category 'R' – Radio is responsible for all parts of the radio systems included in the Type Rating.
- 11.3 The holder of a Type Rated Licence in Category 'R' – Radio may issue Certificates of Release to Service in respect of maintenance, excluding overhaul, of components and parts for which the holder is responsible provided that units which are supplied as bench tested units may not have their individual parts disturbed, except for the replacement or adjustment of items normally replaceable or adjustable in service.
- 11.4 The holder of a Type Rated Licence in Category 'R' – Radio, endorsed to include the overhaul of radio apparatus, is responsible for and may issue Certificates of Release to Service in respect of the maintenance of components and parts of all radio apparatus undergoing periodic check, repair or overhaul in workshop for which the Licence is Type Rated, provided that the work done does not involve the making of radio components or parts.
- 11.5 The holder of a Type Rated Licence in Category 'R' – Radio endorsed including GPWS may issue Certificates of Release to Service in respect of maintenance, excluding overhaul or scheduled maintenance inspection, of Ground Proximity Warning Systems for aircraft for which the licence is Type Rated in respect of its radio systems, subject to the limitations of sub-paragraph 11.3.

12 Compass Compensation and Adjustment

The Paragraph 15 type rating of CAP 562 Leaflet H-30 permits the issue of Certificates of Release to Service by the holder in respect of the compensation and adjustment of direct and remote reading compasses on any aircraft.

13 Part-66 Category A Aircraft Maintenance Licence

- 13.1 A Part-66 Category A Aircraft Maintenance Licence (AML) may be issued to a person who has demonstrated a competence to complete minor scheduled line maintenance and simple defect rectification. The licence does not entitle the holder to exercise any certification privileges in respect of aircraft unless and until the holder is issued with a corresponding Certification Authorisation. Such authorisations will be issued by a Part-145 maintenance organisation appropriately approved by the Competent Authority of a European Union Member State (EU Competent Authority) or EASA. This means that the Part-66 Aircraft Maintenance Licence issued by the UK CAA can readily be used as the basis for a certification authorisation throughout European Union Member States.

NOTES: 1) It should be noted that a Part-66 licence may not provide for full equivalence in another Member State to certify for work relating to any National legislation which sits outside of Part-145. Additional language requirements may also apply.

2) The holder of an unrestricted Category B1 licence is also qualified as a Category A licence holder in the same sub-category, e.g. Aeroplanes Turbine, and may be issued with Category A certification authorisation.

13.2 These Category A privileges will be limited to the performance and certification of specific simple maintenance tasks, either individually or in combination, as defined in Part 145 AMC 145.A.30 (g) and will require a combination of theoretical and practical training to be undertaken on each aircraft type to qualify for the task authorisation. Such authorisation, issued by an Approved Part-145 Maintenance Organisation will specify the limitations of the privileges that may be applicable. Licence holders will therefore be required to act in accordance with the authorisation procedures of the company concerned.

14 Part-66 Category B1 Aircraft Maintenance Licence

14.1 A Part-66 Category B1 Aircraft Maintenance Licence (AML) may be issued to a person who has met the qualification and experience requirements to complete maintenance, including aircraft structure, powerplant and mechanical and electrical systems. Replacement of avionic line replaceable units, requiring simple tests to prove their serviceability, shall also be included in the privileges. The Category B1 licence is primarily intended to be used for the purposes of qualification of line maintenance staff for authorisation. The licence, in its own right, does not entitle the holder to exercise any certifying privileges in respect of aircraft and will be used in conjunction with a Part-145 or Part-M subpart F certification authorisation.

NOTE: Notwithstanding paragraph 14.1 above, certain limited certification privileges based on a Type Rated Part-66 Licence may be exercised in accordance with Part M.A.801(b)2. (See also CAP 562 Leaflet H-30, paragraph 1.2 Note 2.)

14.2 Such authorisations will be issued by a Part-145 or Part-M subpart F maintenance organisation appropriately approved by the competent Authority of a European Union member state or EASA. This means that the Part-66 Aircraft Maintenance Licence issued by the UK CAA can readily be used as the basis for a certification authorisation throughout the European Union member states. Part 145.A.30 (h) also requires it to be used as a prerequisite for authorisation of staff acting as inspectors or supervisors within base maintenance. Licence holders will therefore act in accordance with the authorisation procedures of the company concerned.

NOTE: It should be noted that a Part-66 licence may not provide for full equivalence in another EU Member State to certify for work relating to any National legislation which sits outside of Part-145. Additional language requirements may also apply.

14.3 Category B1 licences apply to aircraft (aeroplanes and helicopters) and are issued in licence sub-categories which are:

B1.1 Aeroplanes Turbine

B1.2 Aeroplanes Piston

B1.3 Helicopters Turbine

B1.4 Helicopters Piston

NOTE: An unrestricted B1 sub-category entitles the holder to be granted Category A certification authorisations in the same sub-category, e.g. Aeroplanes Turbine.

14.4 Category B1 certification authorisations allow the holder to issue Certificates of Release to Service under Part 145 or Part-M subpart F for line maintenance on aircraft which are endorsed as individual types on the licence and the corresponding authorisation. Category B1 licences to the full Part-66 standard include scope to allow the issue of a certification authorisation covering work on a combination of the following disciplines:

- airframe and their related systems;
- engines and their related systems (including Auxiliary Power Units);
- electrical power generation and distribution systems (power distribution in respect of airframe and/or engine systems) including lighting systems (this includes all electrical components in mechanical systems such as sensors, motors and control units);
- avionic line replaceable units (LRU).

In respect of avionic LRUs, the work is limited to cases where the serviceability of the system can be established by a simple self test facility (BITE) or by using simple test equipment and it is expected that, for reference purposes, a list of such components will be prepared for each aircraft type by the Part-145 or Part-M subpart F approved organisation. (Defect rectification on avionic systems which requires an element of decision making in its application other than a simple go/no go decision cannot be certified).

NOTE: The Category B1 licence holder is not entitled to certify for any overhaul work.

14.5 The certification authorisation can only be issued by a Part-145 or Part-M subpart F organisation when the licence holder has the appropriate basic sub-category listed and the aircraft type rating endorsed on the Part-66 Aircraft Maintenance Licence. The type training for a Category B1 type endorsement, conducted under a Part-147 approval, will represent the appropriate technologies as specified in Part-66. The certification authorisation will specify the privileges for the individual, giving due regard to the company scope of approval and any associated procedures agreed with the Competent Authority, and will specify any limitations to the authorisation accordingly.

NOTES: 1) As of 28 September 2008 a Certificate of Release to Service may be issued for maintenance on a non-large aircraft, not operating as commercial air transport, based on a Part-66 licence extended with the appropriate type rating in accordance with Part-M. This maintenance is limited to items not included in the list at Part-M Appendix VII.

2) A Part-66 licence issued on the basis of protected rights may contain technical restrictions equivalent to the limitations of any BCAR Section L licence or company authorisations previously held. These protected rights under Part-66 are a continuation of certifying privileges under an existing licence or certifying authorisation which allows current personnel to continue working and certifying without the need to re-qualify. Authorisations issued by a Part-145 organisation should therefore be similarly restricted in scope. It should be noted that conversion to the full Part-66 licence standard is optional.

14.6 Part-66 Category B1 licences issued by the UK CAA may also allow the certification, under the provisions of Articles 25, 26, 28, 29, 30 and 31 of the Air Navigation Order 2009 (as amended), for work outside of a CAA approved maintenance organisation on aircraft which are not operated for commercial air transport. Such privileges are limited to UK registered aircraft only. Certifications may only be made for those aircraft types which are endorsed individually or as Group Type Ratings on the licence. The privileges will reflect the current limitations for relevant BCAR Section L licence categories highlighted earlier in the appropriate paragraphs of this Leaflet unless specified otherwise.

15 Part-66 Category B2 Aircraft Maintenance Licence

15.1 A Part-66 Category B2 Aircraft Maintenance Licence (AML) may be issued to a person who has demonstrated a competence to complete maintenance on avionic and electrical systems. The Category B2 licence is primarily intended to be used for the purposes of qualification of avionic line maintenance staff for authorisation. The licence, in its own right, does not entitle the holder to exercise any certifying privileges in respect of aircraft and will be used in conjunction with a Part-145 or Part-M subpart F certification authorisation.

15.2 Such authorisations will be issued by a Part-145 or Part-M subpart F maintenance organisation appropriately approved by the competent Authority of a EU Member State. This means that the Part-66 Aircraft Maintenance Licence issued by the UK CAA can readily be used as the basis for a certification authorisation throughout the EU Member States. Part 145.A.30 (h) also requires it to be used as a prerequisite for authorisation of staff acting as inspectors or supervisors within base maintenance. Licence holders will therefore act in accordance with the authorisation procedures of the company concerned.

NOTES: 1) It should be noted that a Part-66 licence may not provide for full equivalence in another EU Member State to certify for work relating to any National legislation which sits outside of EASA requirements.

2) A Category B2 licence cannot be used for the purposes of a Category A certification authorisation unless the Category A licence is also held.

2) As of 28 September 2008 a Certificate of Release to Service may be issued for maintenance on a non-large aircraft, not operating as commercial air transport, based on a Part-66 licence extended with the appropriate type rating in accordance with Part-M. This maintenance is limited to items not included in the list at Part-M Appendix VII.

15.3 Category B2 certification authorisations allow the holder to issue Certificates of Release to Service under Part 145.A.50 for the line maintenance on aircraft which are endorsed as individual types on the licence and the corresponding authorisation. Category B2 licences to the full Part-66 standard include scope to allow the issue of a certification authorisation covering work on a combination of the following aircraft systems:

- instruments;
- automatic pilots (aeroplanes, helicopters and autoland systems);
- radio communication/navigation;
- radio radar;
- electrical power generation and distribution systems (power distribution in respect of avionic systems) including lighting systems.

Scope is not included for authorisation in respect of work on electrical power distribution systems or electrical/avionic components in mechanical systems.

NOTE: The Category B2 licence holder is not entitled to certify for any overhaul work.

15.4 The certification authorisation can only be issued by a Part-145 or Part-M subpart F organisation when the licence holder has the appropriate basic category B2 listed and the aircraft type rating endorsed on the Part-66 Aircraft Maintenance Licence. The type training for a Category B2 type endorsement, conducted under a Part-147 approval, will represent the appropriate technologies as specified in Part-66. The certification authorisation will specify the privileges for the individual, giving due regard to the company scope of approval and any associated procedures agreed with the EU Competent Authority, and will specify any limitations to the authorisation accordingly.

NOTE: A Part-66 licence issued on the basis of protected rights may contain technical restrictions equivalent to the limitations of any BCAR Section L licence or company authorisations previously held. These protected rights under Part-66 are a continuation of certifying privileges under an existing licence or certifying authorisation which allows current personnel to continue working and certifying without the need to re-qualify from scratch. Authorisations issued by a Part-145 organisation may therefore be similarly restricted in scope. It should be noted that conversion to the full Part-66 licence standard is optional at present.

- 15.5 Part-66 Category B2 licences issued by the UK CAA may also be issued with an endorsement, within an Annex to the licence, allowing the certification, under the provisions of Articles 25, 28, 29, 30 and 31 of the Air Navigation Order 2009 (as amended) (national privileges), for work outside of a CAA approved maintenance organisation on aircraft which are not operated for commercial air transport. Such privileges are limited to UK registered aircraft only. Certifications may only be made for those types which are endorsed individually or as BCAR Section L Group Type Ratings on the licence. The limitations will reflect the current limitations for relevant BCAR Section L licence categories highlighted earlier in the appropriate paragraphs to this Leaflet unless specified otherwise.

16 Part-66 Category B3 Aircraft Maintenance Licence

- 16.1 The Part-66 Category B3 licence affords similar privileges as the Category B1 but is restricted to 'piston-engine non-pressurised aeroplanes of 2000 kg MTOM and below'.
- 16.2 A Category B3 aircraft maintenance licence shall permit the holder to issue Certificates of Release to Service and to act as B3 support staff in the same manner as a Category B1. However the Category B3 is NOT type rated therefore any authorisation applies to all aircraft that meet the definition.
- 16.3 The holder of a Category B1.2 licence automatically qualifies as meeting the requirements for the Category B3. Any such B1.2 licence will be automatically extended to include the Category B3 at next submission to the competent authority.

17 Part-66 Category C Aircraft Maintenance Licence

- 17.1 A Part-66 Category C Aircraft Maintenance Licence (AML) may be issued to a person who has demonstrated a competence to release an aircraft following Base Maintenance. The privileges apply to the aircraft in its entirety in a Part-145 organisation. The licence, in its own right, does not entitle the holder to exercise any certifying privileges in respect of aircraft and will be used in conjunction with a Part-145 certification authorisation.
- 17.2 Such authorisations will be issued by a Part-145 maintenance organisation appropriately approved by the Competent Authority of an EU Member State. This means that the Part-66 Aircraft Maintenance Licence issued by the UK CAA can readily be used as the basis for a certification authorisation throughout the EU Member States. Licence holders will therefore act in accordance with the authorisation procedures of the company concerned.

NOTES: 1) It should be noted that a Part-66 licence may not provide for full equivalence in another EU Member State to certify for work relating to any National legislation which sits outside of Part-145. Additional language requirements may also apply.

2) Category C licences at present only apply to aircraft greater than 5700 kg Maximum Take-Off Mass (MTOM).

- 17.3 Category C certification authorisations allow the holder to issue Certificates of Release to Service under Part-145.A.50 following the completion of base maintenance on aircraft which are endorsed on the licence and the corresponding authorisation as individual types. Such persons are in essence certifying for the completion of the process associated with base maintenance and are supported by appropriately qualified and experienced category B1 and B2 staff, who will inspect and supervise the actual work. The scope of coverage therefore reflects the whole aircraft and is not limited to certification of solely mechanical or avionic systems.
- 17.4 It should be noted that a Category C licence holder cannot be authorised to act as Category B certifying staff, exercising line maintenance certification privileges, nor conducting base maintenance, in the role of an inspector or supervisor clearing individual tasks, unless the licence is also endorsed with the appropriate Category B1 and/or B2 licence.
- 17.5 The certification authorisation can only be issued by a Part-145 organisation when the licence holder has the basic Category C listed and the aircraft type rating endorsed on the Part-66 Aircraft Maintenance Licence. The type training for a Category C type endorsement, conducted under a Part-147 approval, will represent the appropriate mix of systems knowledge as specified in Part-66. The certification authorisation will specify the privileges for the individual, giving due regard to the company scope of approval and any associated procedures agreed with the EU Competent Authority.

NOTE: A person qualified to Category B1 or B2 level with type endorsements will also be eligible for a Category C type authorisation, providing the basic Category C licence is held.

18 Part-66 General

Holders of Part-66 AML with type endorsements may be required to undertake appropriate differences type training where the aircraft type to be authorised embodies significant variations in the equipment fitted or the aircraft systems configuration. The responsibility for determining the training to be undertaken will remain with the Part-145 maintenance organisation.

Commission Regulation 216/2008 Annex II refers to aircraft types which have not been adopted under Commission Regulation (EC) 2042/2003. Certification on these aircraft types will continue under National licensing requirements. The UK CAA will continue to issue National licences, (BCAR Section L), for this purpose for the time being.

It is anticipated however, that in the future these aircraft types will be endorsed into an annex to a Part-66 licence, thereby combining the two documents. The certification basis for the Annex II types will remain as National Requirements.

INTENTIONALLY LEFT BLANK

Leaflet H-30 Aircraft Maintenance Engineers Licences – Type Ratings

NOTE: It is proposed to replace the current BCAR Section L with a document that aligns with EASA regulation. However, this cannot take place until such time as 'Airships' is included in the Part-66 licence. The next amendment to Part-66 to include ELA aircraft, Balloons and Airships is expected late 2014 to mid 2015.

1 Introduction

1.1 When reading this document, the reader must take into account Commission Regulation (EC) No. 2042/2003. The Commission Regulation is a legal document, which applies to the UK aviation industry.

1.2 This Leaflet sets out the Type Ratings that may be endorsed upon a BCAR Section L for Aircraft Maintenance Engineers' Licence or a Part-66 Aircraft Maintenance Licence issued by the United Kingdom Civil Aviation Authority in respect of the certification of aircraft registered in the United Kingdom, including also their engines and systems.

NOTES: **1)** A licence can only be used to certify for non-commercial air transport. Aircraft which are operated for commercial air transport must be maintained by a Part-145 Approved Organisation and all staff who certify for maintenance within those organisations must be in possession of a valid certifying authorisation (see CAP 562 Leaflet C-20).

2) As of 28 September 2008 Certification of Maintenance on aircraft using a licence as authority is limited to items which are not listed at Part-M Appendix VII.

2 General

2.1 The requirements for the grant, extension and renewal of BCAR Section L Aircraft Maintenance Engineers' Licences are contained in the current Issue of BCAR Section L. For full understanding of the requirements, Section L must be read in conjunction with this Leaflet.

NOTE: As of November 2006, new BCAR Section L Licences shall not be issued except where required to certify (EC) Regulation 216/2008 Annex II aircraft.

2.2 The requirements for the grant, variation or renewal of Part-66 Aircraft Maintenance Licences are contained in Commission Regulation (EC) No. 2042/2003. For full understanding of the requirements, Part-66 within Commission Regulation (EC) No. 2042/2003 must be read in conjunction with Acceptable Means of Compliance (AMC) to Part-66 and Guidance Material to Part-66, this Leaflet and, where appropriate, Part-145. Part-66 Category B1 licences issued by the UK CAA may also allow the certification, under the provisions of Articles 25, 26, 28, 29, 30 and 31 of the Air Navigation Order 2009 (as amended), for work outside of a CAA approved maintenance organisation on aircraft which are not operated for commercial air transport. Such privileges are limited to UK registered aircraft only. Certifications may only be made for those aircraft types which are endorsed individually or as Group Type Ratings on the licence, otherwise, a Part-66 licence must be used in conjunction with a Part-145 certification authorisation (see Part-145 and CAP 562 Leaflet H-20).

- 2.3 The requirements of BCAR Section L and Part-66 recognise the standards prescribed by the International Civil Aviation Organisation (ICAO) for the grant and extension of licences.

3 Applicability

NOTE: The following paragraphs apply to BCAR Section L licences only.

- 3.1 Where a type of aircraft (or its engines or systems) is defined by one of the Group Type Ratings in paragraphs 5 to 9, 12, 13 or 15 of this Leaflet, an engineer may exercise the certification privileges in respect of that type, subject in particular to the provisions of CAP 562 Leaflet H-20 and provided that:
- he holds a valid UK CAA issued Type Rated Licence, and
 - an aircraft of the type is registered in the United Kingdom and holds a United Kingdom issued Certificate of Airworthiness.
- 3.2 Where a type of aircraft (or its engines or systems) is listed individually within paragraphs 5, 6, 7 and 10 of this Leaflet, the licence holder has certification privileges in respect of the individual types as listed on the licence, subject in particular to the provisions of CAP 562 Leaflet H-20.
- 3.3 Where a type of aircraft (or its engines or systems) is not defined by a Group Type Rating or is not listed by name, an application for the Type Rating of a licence in respect of that type of aircraft, engines or systems, will be considered provided that:
- an aircraft of the type is registered in the United Kingdom and holds a United Kingdom issued Certificate of Airworthiness; and
 - the aircraft does not exceed 5700 kg MTOM.

4 Categories 'A' 'B' 'C' 'D' Aeroplanes, Engines and Rotorcraft

4.1 Specific Type Ratings

- 4.1.1 Type Ratings may be granted for specific aircraft and/or engines defined by, or listed in, paragraphs 5, 6 or 7 of this Leaflet, except as indicated in sub-paragraphs 4.1.2, 4.1.3 and 4.1.4.
- 4.1.2 A Type Rating in Category 'B' – Aeroplanes, will not be granted in respect of an unpressurised aeroplane exceeding 5700 kg MTOM, an aeroplane in which the primary structure is of reinforced plastic/epoxy manufacture, or any pressurised aeroplane.
- 4.1.3 A Type Rating in Category 'D' – Engines, will not be granted in respect of a piston engine with a power rating exceeding 500 kW (670 bhp), or any jet- or propeller-turbine engine (not available for new licence issue).
- 4.1.4 A Type Rating in Category 'B' – Rotorcraft, will not be granted in respect of a turbine-engined rotorcraft exceeding 2730 kg MTOM.

4.2 Group Type Ratings

- 4.2.1 A Group Type Rating granted in relation to sub-paragraphs of paragraph 5, 6 or 7 of this Leaflet includes all the aeroplanes, engines, or rotorcraft defined by that sub-paragraph except as limited by sub-paragraphs 4.2.4 or 4.2.5.

- 4.2.2 Group Type Ratings for Categories 'A' and 'C' may be granted for a group of aeroplanes, engines or rotorcraft defined by sub-paragraphs 5.0, 5.1, 5.7, 5.7.1, 5.9.1, 6.0, 6.3, 7.1 or 7.3 only.
- 4.2.3 Licence holders with Group Type Ratings in Categories 'A', 'B', 'C' or 'D' for sub-paragraphs 5.2, 5.2.1, 5.3, 5.3.1, 5.4, 5.5, 5.5.1, 6.1, 6.2, 6.3.1 and 6.4 may continue to exercise the privileges of the licence for the types defined by these groups subject to any limitations endorsed on the licence.
- 4.2.4 Group Type Ratings for Category 'B' – Aeroplanes or rotorcraft, may be granted for sub-paragraphs 5.1, 5.7, 5.7.1, 7.1 and 7.3, excluding any rotorcraft exceeding 2730 kg MTOM.
- 4.2.5 Group Type Ratings for Category 'D' – Engines may be granted on existing Category D licences for sub-paragraphs 6.0 and 6.3, and includes rotorcraft and airship engines, but excludes engines with a power rating exceeding 500 kW (670 bhp).
- 4.2.6 Sub-paragraphs indicated thus * in this Leaflet are not obtainable as new endorsements on a licence.

5 Category 'A' and 'B' Aeroplanes

- 5.0 Composite Materials Aeroplanes Not Exceeding 5700 kg MTOM (not available in Category B).
- 5.1 Wooden and Wood and Metal Aeroplanes:
Aeroplanes where the primary structure is manufactured from wood or combinations of wood and metal.
- 5.2 *Unpressurised metal aeroplanes not exceeding 2730 kg MTOM.
- 5.2.1 *Unpressurised metal aeroplanes not exceeding 2730 kg MTOM with fixed landing gear only.
- 5.3 *Unpressurised metal aeroplanes not exceeding 5700 kg MTOM.
- 5.3.1 *Unpressurised metal aeroplanes not exceeding 5700 kg MTOM with fixed landing gear only.
- 5.4 *Unpressurised metal aeroplanes, but excluding aeroplanes defined in paragraph 14 of this Leaflet.
- 5.5 *Pressurised metal aeroplanes not exceeding 5700 kg MTOM and all unpressurised metal aeroplanes, but excluding aeroplanes defined in paragraph 14 of this Leaflet.
- 5.5.1 *Pressurised and unpressurised metal aeroplanes not exceeding 2730 kg MTOM.
- 5.6 Reserved.
- 5.7 Unpressurised metal aeroplanes not exceeding 5700 kg MTOM.
- 5.7.1 Unpressurised metal aeroplanes not exceeding 2730 kg MTOM.
- 5.8 Unpressurised metal aeroplanes exceeding 5700 kg MTOM.
- 5.9 Individual pressurised metal aeroplanes exceeding 2730 kg MTOM, but not exceeding 5700 kg MTOM.
- 5.9.1 Pressurised metal aeroplanes not exceeding 2730 kg MTOM.

6 Category 'C' and 'D' – Engines

- 6.0 Diesel engines in aeroplanes.
- 6.1 *Unsupercharged reciprocating piston engines, excluding Diesel engines, fitted with a fixed pitch propeller.
- 6.2 *Unsupercharged reciprocating piston engines, excluding Diesel engines, fitted with a fixed or variable pitch propeller.
- 6.3 Category 'C' Piston engines in Aeroplanes, excluding Diesel engines.
*Category 'D' Piston engines not exceeding 500 kW (670 bhp) in Aeroplanes/ Rotorcraft/ Airships, excluding Diesel engines.
- 6.3.1 *Piston engines, excluding Diesel engines, in Aeroplanes not exceeding 2730 kg MTOM.
- 6.4 Jet-turbine engines in Aeroplanes not exceeding 22.25 kN (5000 lbf) static thrust including where so endorsed the associated APU installations.
- 6.5 Individual types of propeller turbine engines in aeroplanes (including, where so endorsed, the associated APU installations):
Allison 250 ▲
Garret Airesearch TPE 331
Pratt & Whitney Canada PT6 ▲
Turbomeca Astazou
- NOTE:** For engines annotated ☉ or ▲ see CAP 562 Leaflet H-20, sub-paragraph 4.4.
- 6.6 *Jet turbine engines, in aeroplanes, exceeding 22.25 kN (5000 lbf) static thrust including where so endorsed the associated APU installation.

7 Categories 'A' and 'C' and 'B' – Rotorcraft

- 7.1 Piston-engined rotorcraft.
- 7.2 Reserved.
- 7.3 Turbine-engined rotorcraft not exceeding 2730 kg MTOM.
NOTE: This paragraph includes the Allison 250 and Turbomeca Arriel engines which are annotated ▲ for the purposes of CAP 562 Leaflet H-20, sub-paragraph 6.4.
- 7.4 Individual types of turbine-engined rotorcraft exceeding 2730 kg MTOM:
Aerospatiale SA 365 with Turbomeca Arriel ▲
Agusta 109E with P & W Canada 206 series ☉
Bell 212 with P & W Canada PT6T ▲
Bell 222 with Lycoming LTS 101 ▲
Bell 412 with Pratt & Whitney PT6
Eurocopter EC135 with Arrius (increased all up weight versions)
Eurocopter EC155 with Arriel
MBB BK 117 with Lycoming LTS 101 ▲
McDonnell Douglas 900 with P & W 206 series (increased all up weight versions)

McDonnell Douglas MD902 with P & W Canada 206 series ☉

Sikorsky S76 with Allison 250 ▲

Sikorsky S76 with P & W Canada PT6B ▲

Sikorsky S76 with Turbomeca Arriel ▲

Westland W30 with RR Gem

Westland S55 with BS Gnome ☉

NOTE: For an engine annotated ☉ or ▲ see CAP 562 Leaflet H-20, sub-paragraph 6.4.

8 Category 'X' Instruments

NOTE: As of 28 September 2006 a BCAR Section L licence cannot be used in support of certification of aircraft exceeding 5700 kg MTOM.

- a) A Rating granted in relation to any of the sub-paragraphs 8.1 to 8.4 inclusive, includes all of the instruments fitted to those aircraft in which are installed systems defined by or listed in that sub-paragraph excluding those aircraft listed in paragraph 10, and as limited by paragraph 3 of this Leaflet.
- b) A Rating granted in relation to sub-paragraph 8.8 relates to Instruments – Direct and remote reading compasses only, but excludes compasses on those aircraft listed in paragraph 10, and is limited by sub-paragraph 3.3 of this Leaflet.

NOTES: **1)** A Type Rated Licence which is valid for paragraphs 8.2, 8.3 or 8.4 also includes paragraph 8.1.

2) A Type Rated Licence which is rated for Category 'X' – Instruments now includes the INS, GPWS and compass systems, (excluding compass compensation and adjustment) whether or not these systems are separately endorsed on the licence.

3) Where a system is a combined flight director/ automatic pilot the rating does not include items of equipment associated solely with the automatic pilot.

- 8.1 General aircraft instrument systems but excluding instruments installed on any aircraft which has installed a Flight Director System.
- 8.2 Smiths Flight System
Sperry Zero Reader ZL1, ZL2 Flight Director System.
- 8.3 Flight Director Systems employing air driven gyroscopes (attitude).
- 8.4 Flight Director Systems employing electrically driven gyroscopes (attitudes) but excluding those systems defined in sub-paragraph 8.2.
- 8.5 Reserved.
- 8.6 Reserved.
- 8.7 Reserved.
- 8.8 'X' Instruments (compasses)
Compensation and adjustment of airborne compass and compass systems.

9 Category 'X' – Electrical

A rating granted in relation to any sub-paragraph of paragraph 9 of this Leaflet includes the generation system and the electrical installation in aircraft as defined by that sub-paragraph, as limited by paragraph 3 of this Leaflet.

NOTE: A Type Rated Licence which is valid for paragraphs 9.2 or 9.3 also includes paragraph 9.1.

- 9.1 Aircraft in which the main generation system output is DC (including alternators having a self-contained rectifier system) and in which secondary alternators having an individual power rating not exceeding 1.5 kVA may be fitted.
- 9.2 Aircraft in which the main generation system output is DC and which have installed 'frequency' wild alternators with an individual power rating exceeding 1.5 kVA for auxiliary services.
- 9.3 Aircraft in which the main generation system output is 'frequency wild' AC and DC power is supplied from transformer rectifier units.
- 9.4 Aircraft in which the main generation system output is 'constant frequency' AC from alternators driven by constant speed drive units, or variable speed constant frequency (VSCF) generator/converter systems, and DC power is supplied from transformer rectifier units.

10 Reserved

11 Reserved

12 Category 'R' – Radio

A rating granted in relation to any sub-paragraph of paragraph 12 of this Leaflet includes all the types of radio systems listed in that sub-paragraph, as limited by paragraph 3 of this Leaflet.

NOTE: A Type Rated Licence in Category 'R' – Radio includes Ground Proximity Warning Systems only when the licence is endorsed to that effect.

- 12.1 * Airborne Communication Systems.
- 12.2 Airborne Communication Systems, Airborne Navigation Systems.
- 12.2.1 Airborne Communication Systems and Airborne Navigation Systems installed in aircraft below 5700 kg MTOM, excluding HF communications systems, Passenger entertainment systems, Multiplex systems, CVR and Satellite communication systems.
- 12.3 Airborne radar systems.
- 12.3.1 Airborne radar systems installed in aircraft below 5700 kg MTOM, excluding weather radar and TCAS.

13 Category 'X' – Automatic Pilots

A rating granted in relation to any sub-paragraph of paragraph 13 of this Leaflet includes all the automatic pilot systems defined by that sub-paragraph when installed in aircraft not exceeding 5700 kg MTOM and as limited by paragraph 3 of this Leaflet.

- NOTES:**
- 1)** A Type Rated Licence which is valid for paragraph 13.2 also includes paragraph 13.1.
A Type Rated Licence which is valid for paragraph 13.3 also includes paragraphs 13.1 and 13.2.
A Type Rated Licence which is valid for paragraph 13.5 also includes paragraph 13.4.
 - 2)** For the purpose of licensing, automatic stabilisers are deemed to be automatic pilots.
 - 3)** Automatic pilots include related systems such as yaw dampers and/or roll dampers, mach trim systems and automatic throttle systems.

- 13.1 Non-Radio-Coupled Automatic Pilots (Aeroplanes)
- 13.2 Radio-Coupled Automatic Pilots (Aeroplanes) excluding ILS Coupled (LOC and GS) Automatic Pilots
- 13.3 ILS Coupled (LOC and GS) Automatic Pilots (Aeroplanes)
- 13.4 Non-Radio-Coupled Automatic Pilots (Rotorcraft)
- 13.5 Radio-Coupled Automatic Pilots (Rotorcraft)

14 Reserved

15 Compass compensation and adjustment

Compensation and adjustment of airborne compass and compass systems.

16 Part-66 Category B1, B2 and C Type Ratings

The requirements for the grant, variation or renewal of Aircraft Maintenance Licences are contained in Commission Regulation (EC) No. 2042/2003. It is possible to obtain aircraft type ratings in accordance with the provisions of this requirement.

The aircraft types are listed in Appendix 1 to Part-66 (AMC) and will be granted only where the requirements of Part-66 have been met.

17 Aircraft Type Lists

Aircraft type list Commission Regulation 2042/2003 Appendix 1 AMC Part-66
Refer to www.caa.co.uk
Aircraft type definitions Commission Regulation 216/2008 Annex II
Refer to www.caa.co.uk

INTENTIONALLY LEFT BLANK

Leaflet H-40 Personnel Authorisation Systems for Sailplanes and Balloon Certifying Staff in Part M Subpart F Organisations

1 General

1.1 This Leaflet permits persons to be granted, by the holder of a Part M Subpart F approval issued by the CAA, Authorisations to issue Certificates of Release to Service when the CAA has agreed the conditions of such Authorisations. This Leaflet provides guidance to assist organisations in determining the conditions, which may be agreed by the CAA.

NOTES: 1) Compliance with this Leaflet does not provide a basis for the grant of personnel certification privileges outside of a Part-M Subpart F organisation.

2) The introduction of specific requirements for sailplanes and balloons into Part 66 would put in place European legislative provisions that render the Authorisation concept defined here obsolete. Authorisations systems agreed under this Leaflet may not therefore be used once any new legislation comes into effect.

Approved organisations wishing to issue certifying staff Authorisations shall develop suitable procedures to determine the competence of staff to hold such authorisations, and to manage and control the process within their organisation. These procedures shall clearly define the limits to which Authorisations can be granted. The proposed procedure shall be submitted initially through the responsible CAA Regional Office for approval and when approved shall be contained within an organisation's Maintenance Organisation Manual.

1.2 The CAA has chosen not to define, in detail, acceptable boundaries in respect of defect diagnosis and the types of test equipment that are compatible with the Authorisation concept. Such definitions would inevitably produce a set of unnecessarily restrictive requirements.

1.3 The following shall be observed when developing suitable procedures:

1.3.1 Age

An applicant shall be not less than 18 years of age.

1.3.2 Experience

An applicant for an Authorisation shall have had the following minimum experience in the inspection, servicing and maintenance of sailplanes or balloons, as appropriate:

- a) For the issue of Authorisation privileges for a sailplane or balloon in its entirety, at least:
 - i) four years of relevant maintenance experience; or
 - ii) two years if the applicant has satisfactorily completed an approved training course.
- b) For the issue of a restricted Authorisation, a period of time agreed by the CAA that will enable a level of competency equivalent to that required by a) to be obtained, provided that this is not less than two years.

1.3.3 **Knowledge**

It shall be established by the organisation that applicants have an adequate knowledge of a relevant sample of the type(s) of sailplanes or balloons gained through a formalised training course including documented evidence of practical experience. Formalised training courses may be replaced by demonstration of knowledge, by documented evidence of experience and by an assessment performed by a Part M Subpart F organisation in accordance with procedures agreed by the CAA.

This assessment shall include:

- a) relevant parts of initial and continuing airworthiness regulations;
- b) relevant parts of operational requirements and procedures, if applicable;
- c) the organisation's maintenance organisation manual;
- d) knowledge of a relevant sample of the type(s) of sailplanes/balloons/airships gained through training and/or work experience;
- e) maintenance practices and techniques.

Records shall be maintained including:

- results of assessments;
- records of syllabi;
- names and position of assessors.

1.3.4 **Continued validity**

The organisation shall ensure that all certifying staff are involved in at least six months of actual relevant sailplane or balloon component maintenance experience in any consecutive two year period. For the purpose of this supplement 'involved in actual relevant sailplane or balloon maintenance' means that the person has worked in a sailplane or balloon maintenance environment and has exercised the privileges of the certification authorisation and/or has actually carried out maintenance on at least some of the sailplane/balloon type systems specified in the particular certification authorisation.

Leaflet H-50 Implementation of the Railways and Transport Safety Act 2003 – Aviation: Alcohol and Drugs

1 Introduction

- 1.1 The information contained in this Leaflet has been developed in conjunction with the Department for Transport, the Home Office and the Police, and is consistent with the criteria contained in the Police Protocol. It is anticipated that this will facilitate a consistent approach by relevant parties.
- 1.2 The aim of this Leaflet is to inform Licensed Aircraft Maintenance Engineers of this new legislation and how it affects them in the performance of their duties.

2 Legislative Background

- 2.1 The effect of intoxication, through alcohol or drugs, on aviation personnel has significant safety implications. The Air Navigation Order (ANO), which is the main aviation safety regulatory legislation, provides that no member of an aircraft's crew, a licensed aircraft maintenance engineer or an air traffic control officer shall be under the influence of alcohol or drugs to such an extent as to impair his/her capacity to carry out their duties. The ANO, however, does not set a blood alcohol limit nor does it require a person who is suspected of an alcohol or drugs offence to be subjected to a test.
- 2.2 In 1996, the Government issued a Consultation Paper on alcohol and drug testing for aircraft crew and other safety critical civil aviation personnel, which proposed the introduction of a blood/alcohol limit for certain aviation personnel, together with corresponding Police powers of enforcement. Responses to the consultation were broadly supportive of the Government's approach. Part 5 of the Railways and Transport Safety Act 2003 www.legislation.hmso.gov.uk/acts/acts2003/20030020.htm represents the first suitable legislative opportunity to take forward these proposals and now brings aviation into line with other transport modes in seeking to tackle alcohol or drug misuse among key personnel. The Police testing and enforcement powers broadly mirror those currently applied on our roads and railways and are based on an officer's reasonable suspicion that an offence either has been, or is in the process of being, committed.
- 2.3 The blood/alcohol limit for aviation personnel is lower than that in shipping or on our roads or railways, but for pilots reflects the Joint Aviation Requirement on Commercial Air Transportation (JAR-OPS) - adopted by the Joint Aviation Authorities (JAA) in 1996 - which requires that crew members of commercial aircraft should not commence a flight duty period with a blood/alcohol level in excess of 20mg of alcohol per 100ml of blood. The adoption of this limit will go towards the harmonisation of standards across most of Europe.
- 2.4 Enforcement of the provisions of the Act is the responsibility of the Police and the Crown Prosecution Service. There is no provision for random testing.

3 Implementation

Part 5 of the Act was brought into force on 30 March 2004.

4 Summary of Part 5 of The Railways and Transport Safety Act 2003 and Commentary on Enforcement

This Part extends to the flight and cabin crew of an aircraft, air traffic controllers and licensed aircraft maintenance engineers in the United Kingdom. It also applies to the crew of an aircraft registered in the United Kingdom wherever it may be in the world. An Explanatory Note may be found at:
www.legislation.hmso.gov.uk/acts/en/03en20-b.htm.

5 Offences – Being Unfit for Duty (Section 92)

Section 92 makes it an offence to perform an aviation function or an ancillary activity whilst impaired through alcohol or drugs.

6 Offences – Prescribed Limit (Section 93)

6.1 This Section makes it an offence to perform or prepare to perform certain aviation-related functions with more than a prescribed level of alcohol in the body.

6.2 The prescribed blood/alcohol alcohol limits are 20 milligrammes of alcohol per 100 millilitres of blood for those activities carried out by aircrew and air traffic controllers, and 80 milligrams per 100 millilitres for licensed aircraft maintenance engineers. The different limits reflect the fact that although licensed aircraft maintenance engineers perform a safety critical role in aviation, they do not necessarily require the same speed of reaction as aircrew or air traffic controllers may need in an emergency situation.

The equivalent limits in respect of breath and of urine are also set out in this section.

6.3 Detailed limits are:

a) When:

- acting as a pilot, cabin crew, flight engineer, flight navigator or flight radio-telephony operator of an aircraft during flight;
- attending the flight deck of an aircraft during flight to give or supervise training, to administer a test, to observe a period of practice or to monitor or record the gaining of experience; or
- acting as an air traffic controller in pursuance of a licence granted under or by virtue of an enactment (other than a licence granted to a student):

the prescribed limit of alcohol is:

- i) In the case of breath: 9 microgrammes of alcohol in 100 millilitres.
- ii) In the case of blood: 20 milligrammes of alcohol in 100 millilitres.
- iii) In the case of urine: 27 milligrammes of alcohol in 100 millilitres.

b) When acting as a licensed aircraft maintenance engineer the prescribed limit of alcohol in respect of the above is:

- i) In the case of breath: 35 microgrammes of alcohol in 100 millilitres.
- ii) In the case of blood: 80 milligrammes of alcohol in 100 millilitres.
- iii) In the case of urine: 107 milligrammes of alcohol in 100 millilitres.

7 Aviation Functions (Section 94)

- 7.1 This section applies the offences of being either over the limit or unfit, to people preparing to carry out an aviation function or otherwise holding themselves ready to carry out one of those functions by virtue of being on duty or standby.
- 7.2 An activity shall be treated as an ancillary function if it is undertaken by a person commencing a period of duty in respect of the function, and as a requirement of, for the purpose of or in connection with the performance of the function during the period of duty. For example, the pre-flight briefing of the flight and cabin crew and any post-flight activity such as filing reports is considered to be an 'ancillary' function.

8 Testing Under the Act

8.1 Preliminary test (i.e. a breathalyser test)

The Act provides that the power to require a person to co-operate with a preliminary test shall apply where:

- a) a constable in uniform reasonably suspects that the person is over the prescribed limit,
- b) a constable in uniform reasonably suspects that the person has been over the prescribed limit and still has alcohol or a drug in his body or is still under the influence of a drug,
- c) an aircraft is involved in an accident and a constable reasonably suspects that the person was undertaking an aviation function, or an activity ancillary to an aviation function, in relation to the aircraft at the time of the accident, or
- d) an aircraft is involved in an accident and a constable reasonably suspects that the person has undertaken an aviation function, or an activity ancillary to an aviation function, in relation to the aircraft.

8.2 A person who, without reasonable excuse, fails to provide a specimen when required to do so in pursuance of this section is guilty of an offence.

8.3 A person commits an offence under the Act if he/she performs an aviation function, or an activity that is ancillary to an aviation function, at a time when his/her ability to perform the function is impaired because of alcohol or drugs. This means that a person can be tested at any time after commencing duty, including standby.

8.4 The Police will determine when to test. As noted above this will in essence be when there are reasonable grounds for suspicion that someone is over the prescribed limit, or when an accident has occurred.

8.5 The Police are empowered to breathalyse and to perform subsequent tests (i.e. blood and urine tests). Police officers have been advised to exercise their powers under the Act as discreetly as circumstances allow and, if possible, in private, particularly where passenger aircraft are concerned. Overtly or insensitively exercising these powers in certain circumstances could have detrimental affect on passenger perception and confidence, and could have commercial implications and liabilities.

The preliminary drug test is dependent on factors not yet finalised.

8.6 Testing following an accident

An accident for these purposes is defined as an unintended event with adverse physical effect. It is unlikely that every accident involving an aircraft will warrant Police exercising any or all of their power under this Act.

9 Reasonable Grounds for Suspicion

- 9.1 Reasonable grounds for suspicion depend upon the circumstances in each case. There must be an objective basis for that suspicion based on facts, information and/or intelligence that are relevant to the likelihood of an offence. Reasonable suspicion cannot be based on generalisations or stereotypical images of certain groups or categories of people as more likely to be involved in criminal activity.
- 9.2 Reasonable suspicion can sometimes exist without specific information or intelligence and on the basis for some level of generalisation stemming from the behaviour of a person. Reasonable suspicion should normally be linked to accurate and current intelligence or information. For example, evidence of impairment from witnesses or from the result of a primary test of an employee by an employer could be sufficient.

10 Procedure in the Event of a Positive Breathalyser Test

- 10.1 If, as a result of an initial Police breath test, an officer has reasonable cause to suspect that a person has more than the prescribed proportion of alcohol in their body, then they can expect to be arrested and taken to a Police station. There, they will be asked to provide a further specimen of breath, blood or urine for laboratory analysis. In practice, this will usually be a specimen of blood, taken by a Police doctor. Failure to provide a specimen without reasonable cause is an offence. Where a sample of blood or urine is taken, he/she will be entitled to request a part of the sample for themselves. He/she will be supplied with a booklet of analysts where they can have their specimen privately analysed if they wish.
- 10.2 Once a blood sample has been taken he/she will probably be released from the Police station on a condition to return at a later date, by which time the Police part of the sample will have been analysed. If the sample is under the limit he/she will probably be told not to attend. If, when he/she attends, the results of the analysis of the sample shows that he/she was over the limit, he/she will be charged with the offence and be given a date to attend court.
- 10.3 After giving a specimen, the Police may detain the individual at the Police station until it appears to the officer that there is no likelihood of them carrying out, or attempting to carry out, an aviation function of the kind for which they have provided a sample, whilst still over the prescribed limit or otherwise impaired through alcohol or drugs.

11 Advice to Engineers

This Leaflet should be read in conjunction with CAP 562 Leaflet H-60, that contains further information on the Licensed Aircraft Maintenance Engineer's responsibilities when medically unfit or under the influence of alcohol or drugs.

12 Penalties and Enforcement Powers (Sections 95, 97 and 98)

12.1 Section 95: Penalty

The penalties set out in section 95 are set at the same level as those currently applying to aircrew and air traffic controllers under Article 241 of the ANO 2009 (as amended). This section will bring the penalty for licensed maintenance engineers under the influence of alcohol or drugs into line with them.

12.2 **Arrest without a warrant (Section 97)**

A constable may arrest a person without a warrant if the constable reasonably suspects that the person is committing an offence under Section 92 (being unfit for duty), or has committed an offence under that Section and is still under the influence of alcohol or drugs.

12.3 **Right of entry (Section 98)**

12.3.1 A Police constable in uniform may board an aircraft if he/she reasonably suspects that he/she may wish to exercise a power by virtue of Section 96 (power to administer tests, etc.) or under Section 97 (arrest without a warrant) in respect of a person who is or may be on the aircraft.

12.3.2 A Police constable in uniform may enter any place if he/she reasonably suspects that he/she may wish to exercise a power by virtue of Section 96 (power to administer tests, etc.) or under Section 97 (arrest without a warrant) in respect of a person who is or may be in that place.

12.3.3 For the purpose of boarding an aircraft or entering a place under this Section, a Police constable may use reasonable force or may be accompanied by one or more persons, e.g. airline personnel, additional Police constables, etc. Officers not used to working on airports or in aircraft and not trained to consider the relevant aspects of health and safety may wish to be accompanied by an agent of the airport or the operator as appropriate.

13 **Disclosure of Information**

13.1 In exercising their powers under this Act, the Police may acquire information that gives cause for serious concern that a person performing a safety critical aviation function is unsuited to hold that position of trust. This acquisition may occur even before their sample of blood or urine has been analysed or they have been charged, for example, where such a person has provided a positive preliminary test.

13.2 Such information may be passed to that person's employer or professional body on grounds of public safety or for the prevention or detection of crime. This will only be carried out with the authority of an officer of Assistant Chief of Police rank.

13.2.1 Any disclosure should provide only that information required to determine whether the offender should continue in their present role pending trial.

13.2.2 If authority to disclose is refused, Police should provide for the analysis of samples to be fast-tracked by the Forensic Science Service and for the offender to be charged, if appropriate, at the earliest opportunity.

13.3 In reality it is likely that if an individual is tested positive whilst on a duty, this will have an immediate impact on their ability to perform their function and will quickly come to the attention of the employer.

14 **CAA Protocol in Suspected Alcohol or Drug Misuse**

In cases where a licensed engineer may be misusing alcohol or drugs, a decision will be made whether there is alcohol or drug dependency that could be a risk to flight safety. If so, the licence may be suspended, or where the licence has been issued by another state, a recommendation to suspend will be sent to the issuing authority. If that is so, he/she will then be invited to take part in a treatment and rehabilitation schedule. If that is successful, the suspension will be lifted. For non-UK licence

holders a recommendation will be sent to the issuing authority that a rehabilitation schedule was completed.

Leaflet H-60 Licensed Aircraft Maintenance Engineers – Personal Responsibility When Medically Unfit or Under the Influence of Drink or Drugs

1 Introduction

- 1.1 The International Civil Aviation Organisation (ICAO) has introduced an amendment to Annex 1 to the Convention on International Civil Aviation which has the effect of extending certain standards and recommended practices to all licence holders. The changes resulting from the amendment are concerned with medical fitness and the use or misuse of intoxicating liquor, narcotics or drugs.
- 1.2 These changes are implemented in the Air Navigation Order 2009 (as amended). Article 33(8) prohibits the exercise of the privileges of an aircraft maintenance engineer's licence when the holder knows or suspects that their physical or medical condition renders them unfit to exercise such privileges. Articles 92, 93 and 94 of the Railways and Transport Safety Act 2003 prohibit a person from acting as a licensed aircraft maintenance engineer if their ability to perform the function is impaired because of drink and drugs.
- 1.3 The Commission Regulation (EC) 2042/2003 (The Continuing Airworthiness Regulation) entered into force on 29 November 2003 and introduced new requirements applicable to licensed aircraft engineers in the U.K.

Annex III Part 66.B.500 to the Continuing Airworthiness Regulation requires a competent authority to suspend, limit or revoke an aircraft maintenance licence in all cases where it has clear evidence that the license holder has carried out maintenance or issued a certificate of release to service when adversely affected by alcohol or drugs.

2 General

- 2.1 An aircraft maintenance engineer's licence authorises the holder, subject to any conditions that may be specified on the licence, to issue various certificates relating to aircraft maintenance. The process of issuing these certificates (Certificates of Maintenance Review, Certificates of Release to Service and Certificates of Fitness for Flight under the 'A' Conditions Flight Release Certificate) and similar certificates for those aircraft detailed within Annex II of Commission Regulation (EC) 216/2008 require clear decisions to be made that directly affect the airworthiness of the aircraft to which they relate. It follows that the quality of these decisions is directly influenced by the physical and mental state of the certifier at the time of certification, and whether or not they are subject to the adverse effects of drink and/or drugs.
- 2.2 The corporate management of all approved maintenance organisations are required to review this Leaflet and implement suitable policies and procedures to make all maintenance staff aware of them. The requirements of Article 33 of the Air Navigation Order 2009 (as amended) and Articles 92, 93 and 94 of the Railways and Transport Safety Act 2003, in addition to an understanding of the requirements placed upon the UK CAA within Part 66.B.500, fall on those who certify the completion of maintenance. The guidance material contained in this Leaflet is equally applicable to all non-licensed personnel engaged in aircraft maintenance tasks and in principle should be adopted throughout the aviation industry as a code of practice. Organisations shall also take note of items in paragraph 3 which require their participation in the areas concerned.

- 2.3 All persons to whom this Leaflet applies should be aware of the guidance material contained herein. It is the responsibility of the individual concerned to ensure that they do not report for duty or certify if they are genuinely unfit. Such persons should also be aware of an organisation's own internal policies and monitoring procedures to verify the above.

3 Guidance

- 3.1 **Fitness** In most professions there is a duty of care by the individual to assess their own fitness to carry out professional duties. This has been a legal requirement for some time for doctors, flight crew members and air traffic controllers. Licensed aircraft maintenance engineers are also now required by law to take a similar professional attitude.

Cases of subtle physical or mental illness may not always be apparent to the individual but as engineers often work as a member of a team any sub-standard performance or unusual behaviour should be quickly noticed by colleagues or supervisors who should notify management so that appropriate support and counselling action can be taken. In particular, a decrease in mental fitness in many cases may be related to stress from within the working environment or to the personal circumstances of the individual. Instances of aggressive behaviour, vagueness and slippage of personal standards (cleanliness, appearance etc.) may be indicative of more serious mental issues. Such issues may bring into question the ability of the individual to be trusted or to maintain the necessary levels of concentration to take appropriate decisions on airworthiness matters.

- 3.2 **Fatigue** Tiredness and fatigue can adversely affect performance. Excessive hours of duty and shift working, particularly with multiple shift periods or additional overtime, can lead to problems. Whilst the safety management aspects of these matters are being addressed through the UK Operators Technical Group individuals should be fully aware of the dangers of impaired performance due to these factors and of their personal responsibilities.

- 3.3 **Stress** Everyone is subject to various stresses in their life and work. Stress can often be stimulating and beneficial but prolonged exposure to chronic stress (high levels or differing stress factors) can produce strain and cause performance to suffer allowing mistakes to occur.

Stress factors can be varied, physical – e.g. heat, cold, humidity, noise, vibration; they can be due to ill-health or worries about possible ill-health; from problems outside the workplace – e.g. bereavements, domestic upsets, financial or legal difficulties. A stress problem can manifest itself by signs of irritability, forgetfulness, sickness absence, mistakes, or alcohol or drug abuse. Management have a duty to identify individuals who may be suffering from stress and to minimise workplace stresses. Individual cases can be helped by sympathetic and skilful counselling which allows a return to effective work and licensed duties.

- 3.4 **Eyesight** A reasonable standard of eyesight is needed for any aircraft engineer to perform their duties to an acceptable degree. Many maintenance tasks require a combination of both distance and near vision. In particular, such consideration must be made where there is a need for the close visual inspection of structures or work related to small or miniature components. The use of glasses or contact lenses to correct any vision problems is perfectly acceptable and indeed they must be worn as prescribed. Frequent checks should be made to ensure the continued adequacy of any glasses or contact lenses. In addition, colour discrimination may be necessary for

an individual to drive in areas where aircraft manoeuvre or where colour coding is used, e.g. in aircraft wiring. Organisations should identify any specific eyesight requirement and put in place suitable procedures to address these issues.

- 3.5 **Hearing** The ability to hear an average conversational voice in a quiet room at a distance of 2 metres (6 feet) from the examiner is recommended as a routine test. Failure of this test would require an audiogram to be carried out to provide an objective assessment. If necessary, a hearing aid may be worn but consideration should be given to the practicalities of wearing the aid during routine tasks demanded of the individual.

It is important to remind employers of individuals working in areas of high ambient noise of the requirement of the Control of Noise at Work Regulations 2005 which require employers to carry out assessments of noise levels within their premises and take appropriate action where necessary.

- 3.6 **Drug and Alcohol Abuse** Drinking problems or the use of illicit or non-prescribed drugs are unacceptable where aircraft maintenance safety is concerned and once identified will lead to suspension of the licence or company authorisation and possibly further licensing action being considered. The introduction of the Railways and Transportation Safety Act 2003 set a blood alcohol limit of 80 mg/100 ml for personnel involved in aircraft maintenance. CAP 562 Leaflet H-50 describes the implications of this act and should be referred to for further guidance.

- 3.7 **Medication** Any form of medication, whether prescribed by a doctor or purchased over the counter and particularly if being taken for the first time, may have serious consequences in the aviation maintenance environment unless three basic questions can be answered satisfactorily:

- a) Must I take medicines at all?
- b) Have I given this particular medication a personal trial for at least 24 hours before going on duty, to ensure that it will not have adverse effects on my ability to work and make sound decisions?
- c) Do I really feel fit for work?

Confirming the absence of adverse effects may need expert advice and General Practitioners, Company Medical Officers and the Medical Division of the Civil Aviation Authority are all available to assist in this matter. Common types of medication in use and their effects are further described in Appendix 1.

- 3.8 **Alcohol** Alcohol has similar effects to tranquillisers and sleeping tablets and may remain circulating in the blood for a considerable time, especially if taken with food. It should be borne in mind that a person may not be fit to go on duty even eight hours after drinking large amounts of alcohol. Individuals should therefore anticipate such effects upon their next duty period. Special note should be taken of the fact that combinations of alcohol and sleeping tablets, or anti-histamines, can form a highly dangerous or even lethal combination.

- 3.9 **Anaesthetics** It should be remembered that following local, general, dental and other anaesthetics, a period of time should elapse before returning to duty. This period will vary depending upon individual circumstances, but may even extend to 24 or 48 hours. Any doubts should be resolved by seeking appropriate medical advice.

4 Summary

- 4.1 The effects of illness, injury or medication on work performance are the direct concern of the individual. Where there is doubt about the ability of an individual to make sound technical decisions, the implications of Article 33 of the Air Navigation Order 2009 (as amended), and Articles 92, 93 and 94 of the Railways and Transport Safety Act 2003, and Part 66.B.500 must be taken into account. While this Leaflet gives some guidance on the issues to be considered it cannot be comprehensive. If individual licence holders or their managers have any doubt they should consult the medical sources mentioned for advice. If there is difficulty in obtaining this advice, the local CAA regional office or the CAA Licensing and Training Standards Department should be contacted in the first instance and they in turn may seek guidance from the CAA Medical Department. The contact details of the CAA regional offices are provided in Leaflet A-10 of this CAP.

Appendix 1

- 1 The following are some of the types of medicine in common use which may impair work performance. This list is not exhaustive and care should be taken in ensuring the likely effects of any prescribed drug are adequately known before taking it.
- a) Sleeping Tablets – These dull the senses, cause mental confusion and slow reaction times. The duration of effect is variable from person to person and may be unduly prolonged. Individuals should have expert medical advice before using them;
 - b) Anti-depressants – These can depress the alerting system and have been a contributory cause of mistakes leading to fatal accidents. A person should stop work when starting anti-depressants and only return when it is clear that there are no untoward side-effects. It is recommended that individuals seek medical advice from their General Practitioner or appropriate medical specialist before returning to work;
 - c) Antibiotics – These may have short-term or delayed effects which affect work performance. It is recommended that individuals seek medical advice from their General Practitioner or appropriate medical specialist before returning to work whilst taking antibiotics;
 - d) Anti-histamine – Such drugs are widely used in cold cures and in the treatment of hay fever, asthma and allergic skin conditions. Many easily obtainable nasal spray and drop preparations contain anti-histamines. Most of this group of medicines tend to make the taker feel drowsy. Their effect, combined with that of the condition, will often prevent the basic three questions (paragraph 3.7 of the Leaflet) from being answered satisfactorily. Admittedly very mild states of hay fever etc., may be adequately controlled by small doses of anti-allergic drugs, but a trial period to establish the absence of side effects is essential before going on duty. When individuals are affected by allergic conditions which require more than the absolute minimum of treatment and in all cases of asthma, one of the above mentioned sources of advice should be consulted;
 - e) ‘Pep’ pills (e.g. containing Caffeine or Amphetamine-like substances) used to maintain wakefulness are often habit forming. Susceptibility to each drug varies from one individual to another, but all of them can create dangerous over-confidence. Over-dosage may cause headaches, dizziness and mental disturbances. The use of ‘pep’ pills whilst working cannot be permitted. If coffee is insufficient, you are not fit for work;
 - f) Drugs for the relief of high blood pressure are proving to be very effective in controlling this condition. The prescribing practitioner should be able to advise on any side effects to be considered;
 - g) Drugs when prescribed for Anti-malaria in normally recommended doses do not usually have any adverse effects. However, the drug should be taken in good time so that the question in paragraph 3.7 b) of the Leaflet can be answered;

NOTE: Although the above are common groups of drugs, which may have adverse effects on performance, it should be pointed out that many forms of medication, which although not usually expected to affect efficiency may do so if the person concerned is unduly sensitive to a particular drug. Therefore no drugs, medicines, or combinations, should be taken before or during duty unless the taker is completely familiar with the effects on him or her of the medication and the drugs or medicines have specifically been prescribed for the individual alone. Again the sources of advice mentioned earlier in this Leaflet should be consulted in cases of doubt.

INTENTIONALLY LEFT BLANK

Chapter 5 Time Limits / Maintenance Checks

Leaflet 5-10 Maintenance Schedules and Programmes – A Guide to Compilation and Development

1 Introduction

2 Schedules and Programmes

- 2.1 What are Maintenance Schedules and Maintenance Programmes?
- 2.2 How to Compile a Schedule or Programme
- 2.3 How to Develop a Schedule
- 2.4 Application for and Approval of Schedules and Programmes

3 New Schedules - Initial Task Compilation

- 3.1 Maintenance Review Boards (MRB)
- 3.2 Maintenance Steering Group (MSG) Analyses
- 3.3 Maintenance Planning Document (MPD)
- 3.4 Types of Task
 - 3.4.1 Mandatory
 - 3.4.2 Zonal Inspection
 - 3.4.3 Lubrication
 - 3.4.4 Inspection Levels
- 3.5 Task Frequency
- 3.6 Engine Tasks
 - 3.6.1 Turbine Engines
 - 3.6.2 Piston Engines

4 Development of Schedules and Programmes

- 4.1 Reliability Programmes
- 4.2 Annual Review
- 4.3 Utilisation
- 4.4 Task Escalation

5 Applicability

- 5.1 Registrations
- 5.2 Mixed Age/Modification Fleets
- 5.3 Adding Aircraft to the Schedule
- 5.3 Bridging Checks

6 Other Considerations

- 6.1 Task Cards/Work Packaging
- 6.2 Repairs
- 6.3 Regulatory Requirements
- 6.4 Special Operations (AWO, RVSM etc.)
- 6.5 Task Variations

1 Introduction

In the early days of aviation, owners and engineers concerned with in-flight failures and component reliability developed Maintenance Schedules to help prevent costly occurrences. As aviation grew and scheduled air transport arrived, safety, reliability and economics became important in order to attract passengers. It became apparent that to achieve a controlled balance between safety and economics Regulatory Authorities needed to ensure minimum standards were maintained and a level playing field existed for fair competition between operators.

What to maintain, when to maintain and how to maintain, is the key to the content of Maintenance Schedules and a system was developed for Operators, Manufacturers and Regulators to share experience and knowledge on these very issues for new aircraft being developed.

Today Commercial Air Transport operators are required to operate to a Maintenance Programme. This is a 'real time system' which consists of a Schedule and a whole group of review and management procedures to ensure that it remains realistic and effective.

In the UK, the Air Navigation Order 2009 (as amended) Article 19 requires all aircraft with a Certificate of Airworthiness to be maintained to a Schedule 'Approved' by the Civil Aviation Authority (CAA). For commercial air transport, operating to EASA requirements, then Regulation 2042/2003 Annex 1 (Part M.A.302) requires that aircraft are maintained in accordance with an 'Approved' Maintenance Programme. For aircraft operating on a Permit to Fly, BCAR (A3-7) states that 'maintenance arrangements must be agreed with the CAA' - which tacitly means a schedule is required. BCAR A8-20 for ex-military aircraft also states that a Maintenance Schedule is required.

This document is intended to give guidance for the compilation of a Maintenance Schedule or Programme that will satisfy the CAA for approval. Further help and guidance can be provided by the manufacturer of the product in question.

2 Schedules and Programmes

2.1 What are Maintenance Schedules and Maintenance Programmes?

2.1.1 Maintenance Schedules

A Maintenance Schedule contains details of what is to be maintained on an aircraft and how often. The details are those as published by the Original Equipment Manufacturer (OEM) who may also be the Type Certificate Holder (TCH) of that product. As the aircraft will consist of an airframe, engine, propeller and other equipment, there will be several sources of basic information. Not only will there be details of 'What and When' but also 'How' the parts are to be maintained; more detail on the types of task that are usually described can be found in paragraph 3.4 of this Leaflet.

For aircraft below 2730 kg MTOM the CAA and EASA permit the use of a generic 'Light Aircraft Maintenance Schedule' (LAMS). Light aircraft Owners have a choice, in that they can follow the Manufacturer's recommended schedule, as found in the aircraft maintenance manual, or they can use LAMS. Most opt to use LAMS, as historically they had to get an alternative schedule approved, which was perceived as too onerous. However, the LAMS system requires that the Manufacturer's recommendations are considered as well, so users of LAMS have to employ both sets of data.

Owners and operators should be aware that properly maintained records not only assist in maintaining the safety of an aircraft but also help retain the resale value of an aircraft.

To assist owners/operators the Authority encourages the use of CAP 543 (Time Limited Task, Additional Inspections and Component Change Record) to be kept in conjunction with LAMS to control the overhaul life of engines, propellers and any other piece of equipment that may be installed.

2.1.2 **Maintenance Programmes**

In its simplest form a Maintenance Programme is an approved schedule with a host of procedures that are designed to continually review its applicability and effectiveness for the aircraft it is approved for. The two principal procedures required are Management interest and a Reliability Programme.

Part M, Appendix 1 to AMC M.A.302 gives a comprehensive list of what should be in a Maintenance Programme and a programme will not be approved unless compliance with that list can be demonstrated. To assist operators with showing compliance, the CAA have produced a form AD981C (free on the CAA web site) that should be submitted with any new Schedule. (Form AD981D has been customised for owners who wish to use LAMS as the basis of their maintenance programme.)

NOTE: For brevity throughout this document the term 'Schedule' will be used to mean either a schedule or programme.

2.2 **How to Compile a Schedule or Programme**

As previously stated, the first place for information is the OEM/TCH documentation that is relevant to the aircraft being operated. As data will be obtained from several manuals, there will be a collection of tasks to be accomplished at varying intervals. These intervals can be based either on flying hours, flight cycles or calendar time and sometimes there are combinations of these. It is quite often inconvenient to take each task as it comes and accomplish it; it is usually expedient to parcel the tasks into packages of work that can be carried out when it is convenient to do so, but at a frequency not exceeding the approval intervals.

The general rule that can be applied for compiling work packages is that tasks can quite often be done earlier than when recommended. They can only be done later with agreement of the CAA and only in exceptional circumstances. So for tasks that have more than one frequency in terms of flying hours and calendar time, then the event that occurs first is normally the governing one.

For Large Transport Aircraft the tasks can be found in Maintenance Planning Documents provided by the TCH, these are described further in part 3 of this Leaflet.

Smaller aircraft usually have the TCH recommended maintenance in the Maintenance Manual (Chapter 5).

The frequency of maintenance tasks is affected by the way the aircraft is to be operated. When the TCH recommendations are first compiled they will have in mind a 'typical' flight profile for the aircraft type; any deviation from this may need an adjustment on the basic recommendations. For example, an aircraft may be designed and its typical operation could be considered to be 'One flying hour to each flight cycle'. Someone may have a version that will fly six hours for every cycle and another may be doing six cycles every hour. It can be seen that in these cases a schedule based solely on flying hours may mean the first aircraft is maintained too often and the other not enough, so, with the help of the TCH, usually a schedule can be developed for any particular type of operation.

The area of operation is another important consideration, for example operating over salt water may require special tasks, such as engine compressor washes and other maintenance, to be done on a more frequent basis. Similarly, operation in sandy areas or off rough strips may affect the tasks required.

The age of an aircraft may affect the number and frequency of tasks, particularly if it has ageing structural inspections and significant repairs.

Significant parts of the aircraft such as make and type of engines, propellers and/or APU should be detailed as quite often operators have a choice of equipment and adding the same type with a different engine to a common schedule will mean careful identification of tasks applicable to each aircraft.

Finally, the modification state of equipment on board has to be considered as it may be unique to the aircraft on any particular schedule.

2.3 **How to Develop a Schedule**

Once established an owner or operator may wish to change the frequency of some tasks away from where the OEM has set them. This can be done with the aid of an amendment to the Schedule, which is submitted to the CAA for their agreement and subsequent approval.

Doing tasks less frequently requires suitable justification in order that it may be approved. Proof that safety will not be compromised must be provided. Maintenance Programmes supported by a reliability programme will have an advantage here as they will readily be able to show how often a task has been performed without deterioration of the item/system.

Again for those with a reliability programme, Part-M gives provision for some 'self development' of the Approved Maintenance Programme (AMP) within parameters and to procedures agreed with the CAA.

More information on schedule/programme development is contained in part 4 of this Leaflet.

2.4 **Application for and Approval of Schedules and Programmes**

For light aircraft, copies of LAMS are available on the CAA website (CAP 411 and 412 refer), no application is required to use this programme.

Application forms (AD981M) for any other type of programme can be found on the SRG website.

3 New Schedules - Initial Task Compilation

3.1 **Maintenance Review Boards (MRB)**

A Maintenance Review Board is formed during the Type Certification process of an aircraft the MTOM of which is greater than 5700 kg. It consists of members of interested National Authorities chaired by the Authority of the state of design/manufacture.

Reporting to the Board is an Industry Steering Committee (ISC) which is a group containing representatives from various working groups who are looking at various aspects of the aircraft's design from a maintenance perspective. The ISC and the working groups will contain members from Authorities, the OEMs and the Operators

Each working group will consist of specialists in that particular discipline (e.g. structures, powerplant, avionics etc.) from interested Authorities, the Design organisation and Operators, usually those who are already customers and have a

vested interest in the meeting outcome. For a particularly advanced design, if the lead Authority believes that the customers do not have sufficient knowledge to contribute then they may invite specialists from operators that do.

Before commencing work the Board will put together a 'Policy and Procedures Handbook', which will describe how the whole review process will work. The final outcome from the ISC will be Maintenance Programme Proposals that is approved by the chairman of the MRB.

If an aircraft type which has been subject to the MRB process is modified by an STC, the systems, powerplant and structure must be reviewed and consideration given to forming an MRB to determine the maintenance requirements.

3.2 **Maintenance Steering Group (MSG) Analyses**

This is basically a process driven by a set of logic diagrams, that are followed by the MRB working groups in order to determine types of and frequency of tasks, depending on component and system failure modes and visibility of those failures to the users.

For more information on MSG analysis contact the Air Transport Association of America on www.airlines.org/home/default.aspx as the owner of this analysis process.

3.3 **Maintenance Planning Document (MPD)**

All the working groups will detail the tasks they have identified during the MSG 3 analysis procedure in an MRB document, which for EASA aircraft is approved by EASA. These tasks, along with other tasks (such as Airworthiness Limitations Items (ALIs)) considered applicable by the OEM/TCH are all published in the MPD and hence this is the stock document an operator of a new type needs in order to start compiling his schedule.

3.4 **Types of Task**

3.4.1 **Mandatory**

3.4.1.1 **Certification Maintenance Requirements (CMR)**

CMRs arise from the aircraft Certification process. CS 25.1309, for example, requires an aircraft System Safety Assessment (SSA) to ensure that failures are categorised on their consequential severity and within defined bounds of probability.

A CMR is a task required to reveal hidden or dormant failures and to ensure that a system meets the SSA target (e.g. <math><1</math> failure in

Major aircraft manufacturers predominantly refer to two types of CMR task:

a) One Star CMR. (CMR*)

Such tasks and intervals are mandatory and cannot be changed or deleted without the approval of the state of certification Authority.

b) Two Star CMR. (CMR**)

Changes to task intervals must be supported by an approved procedure and monitoring programme. Tasks may not be changed or deleted without the agreement of the state of registration Authority.

NOTE: It is important to read carefully the introduction to the TC Holder's data that is being used for the production of a maintenance Schedule/

Programme. Some manufacturers will use a different terminology, for example some TCHs have the opposite definition for one/two star tasks to other TCHs.

CMRs should be clearly identified as such in a Schedule submitted to the Authority for approval.

Any subsequent applications for approval to vary these tasks must be supported by the TCH. Again, care should be taken in understanding the Manufacturer's certification philosophy as some do allow short-term variations of these tasks.

3.4.1.2 **Airworthiness Limitation Items (ALI)**

ALI are structural items that the Certification process has defined as critical from a fatigue point of view during the Damage Tolerance assessment. Again, the inspection frequency of such items is Mandatory and they should be treated in the same way as a CMR*.

These lives are published in a supplement of the MRB report and may not be found in an MPD.

3.4.1.3 **Critical Design Configuration Control Limitation (CDCCL)**

CDCCLs will be listed in a uniquely referenced section within the ALIs. They are design features that have been identified as being critical to the integrity of the Fuel System and must be maintained in order to ensure that unsafe conditions do not develop throughout the service life of the aircraft and must be retained during modification, repair or maintenance.

3.4.1.4 **Other Items**

There are significant parts of aircraft that also have Mandatory lives that are not determined from the Certification process but arise due to their significance and use. Such items might include the rotating assembly within an engine, transmission parts of helicopters and landing gear parts. Details of these items do not have to be in a Schedule/Programme but information on how they are controlled should be.

3.4.2 **Zonal Inspections**

The inspection level for the Zonal tasks in each programme must be clearly defined, since interpretation of the MSG rule may differ between aircraft types and their respective Zonal programmes. The MRB report should provide clearly defined criteria and in most cases this is repeated in the MPD.

General visual or surveillance tasks from the MSG analysis may be appropriate for the Zonal Inspection programme.

The principal of Zonal inspections is to group tasks within an area together, in order to minimise the number of times an area is disturbed. Systems, installations and structure within a zone will all be inspected for security and general condition.

3.4.3 **Lubrication**

During the working group phase of the certification process the MSG analysis has lubrication as the first consideration when looking at reducing a risk of failure of a component or system. It is a relatively quick and cost effective method of preventative maintenance.

Lubrication servicing requirements may either be in the ATA chapters of the schedule with the daily and weekly check or in a specific lubrication section defining the intervals determined by the MRB.

Rescheduling of the lubrication frequency may be necessary if a check cycle is changed or the operating pattern is changed, so that degradation does not result.

Deterioration may take some time to be evident so the effectiveness of a lubrication programme must be monitored.

3.4.4 **Inspection Levels**

There are no defined standards of Inspection level; different manufacturers will have applied their own standards and these need to be understood and published for the schedule/programme user's benefit. Examples of types of Inspection are:

General Visual Inspection - A visual examination of an interior or exterior area, installation or assembly to detect obvious damage, failure or irregularity. Typically this level of inspection is made within touching distance unless otherwise specified. A mirror may be necessary in order to see all exposed surfaces and only available lighting, such as daylight or hangar lighting, may be necessary. Stands, ladders or platforms may be required to obtain adequate access.

Detailed Inspection - An intensive examination of a specific item, installation or assembly to detect damage, failure or irregularity. Available lighting may be supplemented with a direct source at an appropriate intensity. Inspection aids such as mirrors and/or magnifiers may be required. Cleaning of areas may be necessary to carry out inspection.

Special Detailed Inspection - An intensive examination of a specific item, installation, or assembly that may require specialised inspection techniques such as Non-destructive testing or boroscope inspection. In this case intensive cleaning may be required prior to inspection.

Functional Check - A quantitative check to determine if one or more functions of an item performs within specified limits.

3.5 **Task Frequency**

Tasks identified as necessary during the certification programme will have a time interval allocated that is based on the most appropriate parameter to maintain the condition of the item to which the task refers. The three types of frequency are: Flying hours, Flight cycles and Calendar time; sometimes there will be two limits with the operator normally having to comply with whichever comes first in their particular operation.

In cases of structural inspections, the threshold inspection and repeat frequency can vary depending on the type of operation being used. Structural inspections are always based on flight cycle limits as their reliability is directly related to cyclic fatigue.

When reviewing the effectiveness of a Maintenance Programme, or carrying out an annual review of a schedule, it is the frequency of all the tasks that is being considered. Reliability monitoring is the continual monitoring of task frequency; it is permissible to amend these frequencies away from those recommended by the manufacturer by making application to the CAA. As the operation of an aircraft is usually unique to an Operator a conscientious owner/operator will develop their schedule to maximise reliability and minimise costs.

3.6 **Engine Tasks**

Turbine powered engines, by implication, are more complex than Piston ones and the way their lives and reliability are managed is significantly different, so they will be treated separately below.

3.6.1 Turbine Engines

Turbine engine reliability is based on an approved Condition Monitored Maintenance Programme for both on-wing and off-wing tasks. BCAR A6-2 was developed by the CAA to provide guidance as to what should be contained in an 'Engine Maintenance Programme' (EMP). An EMP document becomes part of the aircraft Maintenance Programme.

By implication Auxiliary Power Units, being Turbine powered, are treated in a similar manner.

Engine health management is complicated and requires some expert control. On-wing Health monitoring may include regular oil analysis (SOAP), magnetic plug inspections and boroscope inspection. Modules may have separate lives, generally hot sections being shorter than cold, and Rotating Parts have finite cyclic lives. Removed engines need agreed worksopes and good strip reports all to remain in compliance with the EMP.

3.6.2 Piston Engines

Piston engines work on a 'manufacturer's recommended' overhaul life. The Authority views this 'recommended' life as the life. Some aircraft not used for commercial air transport may have the life of their engine extended beyond that recommended by the manufacturer by closely following the requirements of CAP 747 - Mandatory Requirements for Airworthiness, Generic Requirement (GR) No. 24.

4 Development of Schedules and Programmes

4.1 Reliability Programmes

Part M (M.A.302 (d)) requires that any maintenance Programme based on MSG logic or containing Condition Monitoring tasks should contain a Reliability Programme. There is some guidance in Appendix I to AMC M.A.302 on what constitutes a Reliability Programme. Typically, on a monthly basis an operator will look at Tech log entries, component failures (in particular - cause of failure), delays, Ground or Air safety reports (MORs) and findings from task cards and look for trends or areas of hurt that can be addressed by taking some kind of preventative maintenance action.

Operators whose aircraft are not designated as 'Large' by EASA definition are exempt from this requirement. It has also been found that for fleets of six or fewer aircraft insufficient data is produced to maintain an accurate programme and hence alternative procedures need to be established, whereby events rather than trends are monitored.

4.2 Annual Review

This is a requirement for operators of small aircraft and/or small fleets of aircraft. At least once in a year an owner or operator should sit down with their maintainer and discuss the performance of the aircraft over the preceding period of time. As already stated a good programme will make an aircraft more reliable, cheaper to run and more available so it is really a 'no brainer' to get together and make it right.

4.3 Utilisation

The utilisation of an aircraft is inextricably linked to the effectiveness of a Maintenance Programme. When optimised for a certain utilisation, tasks will lose their effectiveness if the relationship between Flying hours and Cycles varies by a significant amount. The MRB will set task intervals to meet, what they have considered to be a 'typical' flight profile for their product. For example the Boeing 747

might reasonably have been considered to have a profile of about 7 flight hours to one cycle. An operator then chose to use the aircraft on thirty minute sectors. By using the original MRB derived data the operator would suffer failures due to the flight hour tasks not being done soon enough to protect the cyclic dependent parts and systems.

Operators are required to state their expected annual utilisation in the front of the programme. Part of the annual review of effectiveness is to determine that this figure remains within plus or minus 25% of that figure. Significant deviations should be discussed with the TCH to see how tasks may need to be changed.

Quite often manufacturers will produce a 'low utilisation' programme for operators doing very low hours, for example an executive jet operation. This can be a cost effective solution for such an operator.

Finally, Supplemental Structural Inspection Programmes (SSIP) can have different inspection frequencies dependent on the type of operation. Details of these will be found in the introduction of the SSIP document itself.

4.4 **Task Escalation**

Following a period in operation it may be noticed that a particular inspection is carried out routinely and no faults are ever detected. Providing data supporting this can be presented to the CAA, it is possible for the task frequency to be reduced, such that the task is carried out less frequently. This gives an immediate cost saving with no loss of safety or reliability.

This is carried out on a grander scale by the manufacturers, as less frequent tasks mean lower maintenance costs for their product, which they perceive makes it more saleable. They achieve this by holding Industry Steering Committee meetings, where a group of operators and regulators meet with the manufacturer to review the results of scheduled inspections pooled by as many operators as they can get interested. This is basically a way of validating their original predictions for task requirements, which would have been understandably quite conservative.

In order to escalate the tasks, they will revisit the failure rates that type design required that they achieve, and apply operational experience to determine that they can be still be met with less frequent inspections.

5 **Applicability**

An aircraft must be maintained to an Approved Maintenance Schedule. It can only be maintained to **one** Approved Maintenance Schedule at any time. More than one aircraft, however, can be maintained to the same Schedule, providing they all bear similarities that are covered entirely by that Schedule. The introductory part of the Schedule will therefore contain details of the aircraft to which it applies.

To move an aircraft from one programme to another will involve making an amendment requiring the CAA approval to remove it from one Schedule and add it to another, and requires the operator to propose to the CAA a 'B' amendment for each of the affected Schedules. In this case the operator will need to consider the differences between the two Schedules and the need for a 'Bridging Check' to cater for such differences.

5.1 **Registrations**

Aircraft maintained to any Schedule are listed by registration in that document and on a CAA database. If the registration of an aircraft is changed but it remains on the same programme, or new aircraft is added, an amendment will be required to be submitted for CAA approval highlighting the fact.

5.2 **Mixed Age/Modification Fleets**

For a programme with a number of aircraft of the same type on it, the varying ages and modification standards should be catered for, by highlighting affectivity of tasks that apply. For example, should two aircraft out of the fleet have an STC applied that does not feature on the others, then any task relevant to the STC should be included but clearly denoted in the programme which two aircraft it applies to.

It follows that any aircraft being added to a programme is to be assessed by the operator for its modification standard and equipment fit to ensure the programme adequately addresses the needs of the individual aircraft build/change standard. Should any further tasks need to be added, then an amendment should be submitted addressing these needs.

5.3 **Adding Aircraft to the Schedule**

When adding an aircraft to a Schedule an amendment must be submitted to the CAA. As stated above the commonality of the aircraft and the Schedule must be established, in terms of Modification standard, Equipment fit, Structural life inspections etc.

5.4 **Bridging Checks**

A Bridging Check is a set of tasks required to transfer an aircraft from one Schedule to another. As previously discussed, every Operation is unique and hence an aircraft may have been maintained to the same tasks at a different frequency or to different maintenance standards in its previous operation. The Bridging Check is carried out to bring the tasks into line with the new frequencies and standards to ensure standards are met and no task is overrun.

6 **Other Considerations**

6.1 **Task Cards/Work Packaging**

Task management will differ from Schedule to Schedule. In LAMS tasks are grouped by inspection frequency, that is all the 50 hour repeat tasks appear consecutively, followed by the 100 or 150 hour tasks. For a large transport aircraft Schedule, the tasks will probably be grouped in ATA order. This means that consecutive tasks in the Schedule have different inspection frequencies.

In order to save costs operators will want to have the minimum number of maintenance checks done on their aircraft, so they will select items with the same or close frequency and 'package' them into workpacks to be done together.

LAMS comes in a format whereby the tasks are laid out in a way that can be used as a set of worksheets. For the compiler of a workpack, the tasks are usually broken down onto separate 'cards' which can be certified individually as the tasks are accomplished.

Traditionally a large transport aircraft Schedule would contain defined periods of A and B line checks and C and D base checks. Nowadays these tasks are not designated by letter but frequency only, these are termed 'Equalised' Programmes, now the old base tasks can be accomplished along with some of the lesser line tasks in order to make more efficient use down time (overnight stops) and manpower.

The downside of equalised programmes is the complex packaging of the tasks and the added responsibility on the continuing airworthiness management organisation to ensure repeat inspections are controlled properly.

6.2 **Repairs**

Since 1980, large transport aircraft (and latterly some LAMS weight aircraft) have been designed with 'Damage Tolerant' Structures. This means that the designers have calculated with the expected lifetime loads experienced by the aircraft, when significant structural parts will begin to fail from fatigue. In this way they can determine suitable inspection frequencies and techniques to detect fatigue cracks long before the part will fail.

During the aircraft life it will suffer from accidental damage, requiring some repair work to the structure. In most cases the repair will return the damaged part to its 'as was' standard, and routine inspections of that piece of structure will continue as before. In some cases, Damage Tolerance analysis of the repair will require an interim inspection of it before the regular inspection period falls due. This new inspection requirement is now part of the Maintenance Schedule which should be amended to include these inspections.

6.3 **Regulatory Requirements**

The requirements regarding scheduled maintenance are set out in Part-M.A.302 and its associated AMC and JAR OPS, as appropriate to the aircraft, the ANO and CAP 747 Generic Requirements.

6.4 **Special Operations (AWO, RVSM etc.)**

Issues such as All Weather Operations, Reduced Vertical Separation Minima etc. are operational issues, not used by everyone. They do, however, have specific maintenance requirements in order to maintain their accuracy. As such, any of these maintenance requirements must be included in the Maintenance Schedule.

6.5 **Variations**

All maintenance must be carried out at, or before, its specified frequency. In some unforeseen circumstances, the task frequency can be extended by an amount approved by the CAA and detailed in the Schedule by the operator of the aircraft. Typically the frequency can be extended by 10%.

Should the unforeseen circumstances mean that the aircraft cannot meet its maintenance slot even with such a variation, then the operator can approach the CAA with a request for a further extension. His reason will have to be good and the timescale supported by the TCH. If accepted, the extension will be approved as a one off change.

INTENTIONALLY LEFT BLANK

Leaflet 5-20 Standard Maintenance Practices – Introduction

1 Introduction

- 1.1 Standard Maintenance Practices (SMPs) contained within this part are produced by the Airworthiness Evaluation and Surveillance Department in consultation, where necessary, with other Sections of the CAA. They are intended to give guidance and information to originators of maintenance schedules submitted for Approval and the holders of Approved Maintenance Schedules, in respect of the minimum maintenance requirements acceptable to the CAA for the subjects addressed.
- 1.2 Holders of Approved Maintenance Schedules should review and update their schedules, using the normal 'B' amendment procedure, to comply with applicable SMPs.

INTENTIONALLY LEFT BLANK

Leaflet 5-30 Standard Clauses for Insertion in Maintenance Schedule Introductory Pages

The purpose of this Standard Maintenance Practice is to ensure that the introductory pages of Maintenance Schedules are reasonably consistent and, where applicable, include the following items. Minor variation in the wording is acceptable providing that the intention remains clear.

1 Annual Utilisation and Maintenance Review

- 1.1 In the preparation of this Maintenance Schedule Reference to meet the requirements of the Air Navigation Order (ANO) and British Civil Airworthiness Requirements (BCAR), the recommendations made by the constructors and manufacturers have been evaluated and, where appropriate, have been incorporated. It is agreed that it is a duty of the Operator or his contracted Maintenance Organisation that subsequent maintenance recommendations, including airworthiness information promulgated in Service Bulletins, Service Letters, etc., issued by the constructors and manufacturers, should be evaluated and, where appropriate, should be incorporated in this Schedule by approved amendment procedures.
- 1.2 The periods/frequencies of the maintenance tasks in this Schedule are generally based on an anticipated annual utilisation of flying hours and large variations in the annual utilisation of individual aircraft could invalidate the effectiveness of certain tasks. If the annual utilisation varies by more than 25% from that anticipated, the Operator accepts that he, or his contracted maintenance organisation, must review the maintenance tasks and periods with a view to making any necessary adjustments.
- 1.3 In addition to variations in utilisation, the data contained in this Schedule will be reviewed at least annually by the Operator, or his contracted Maintenance Organisation, to ensure that the detailed requirements continue to be valid in the light of operating experience.

2 Maintenance Schedule Applicability

This Maintenance Schedule is applicable only to the following aircraft:

Registration	Type	Serial No.

NOTE: Any changes in aircraft applicability must have prior approval by the CAA.

3 Flying Times

All periods in this Schedule quoted in 'hours flying' are to be calculated and recorded on a 'Take-Off to Touch-Down' basis.

4 Maintenance Schedule Approved as Alternative to CAA/LAMS/FW or CAA/LAMS/H

Maintenance Schedules for aircraft not exceeding 2730 kg MTWA are additionally required to include the Certification requirements contained in CAP 520 Light Aircraft Maintenance.

5 Certification of Maintenance

Attention is drawn to the necessity of ensuring that the appropriate Certification of Maintenance is completed. The requirements are specified in the CAA Approval Document and Endorsements relating to this Schedule.

6 Permitted Variations to Maintenance Periods

The periods prescribed by this Schedule may be varied subject to the conditions and limits contained in Appendix A to this SMP.

7 Airworthiness Directives and Manufacturer's Service Information

- 7.1 European Commission Regulation (EC) No. 2042/2003 Annex I requires Operators to institute a system for the assessment of continuing airworthiness information. This information will originate from the Responsible Authority of the State of Manufacture in the form of Airworthiness Directives (or documents of comparable intent) and from the manufacturer in the form of Service Bulletins, Letters, Information Leaflets, etc. resulting from In-Service experience.
- 7.2 Compliance with the mandatory requirements of the Responsible Authority of the country of origin must be achieved unless this requirement is varied by the CAA.
- 7.3 Continuing Airworthiness and other Service Information must be continuously evaluated by the Operator or the contracted Maintenance Organisation and, where necessary, appropriate action must be taken to amend the Maintenance Schedule.

8 Fatigue Lives and Mandatory Life Limitations

- 8.1 Structural 'fatigue' lives published by the manufacturer or by the CAA are mandatory for aircraft on the UK register (see also BCAR Section A and B). In the case of foreign products the CAA may vary the lives published by the manufacturer or itself publish a life, normally as a CAA Additional Airworthiness Directive.
- 8.2 All other life limitations classified as mandatory by the manufacturer must also be observed unless varied by the CAA.

9 Maintenance Practices and Procedures

The practices and procedures necessary to accomplish the requirements of this Schedule, or work resulting from its application, should be, as a minimum, to the standards recommended in:

- a) relevant Maintenance, Overhaul and Repair Manuals and where applicable
- b) Civil Aircraft Airworthiness Information and Procedures.

10 All Vital Points and Control Systems

- 10.1 Whenever inspections are made or work is undertaken on vital points in flying or engine control systems, a detailed investigation must be made on completion of the task to ensure that all tools, rags or any other loose articles which could impede the free movement and safe operation of the system(s) have been removed and that the system(s) and installation in the work area are clean and unobstructed.
- 10.2 If, as a result of the application of this Schedule, any part of either the main or any associated system is dismantled, adjusted, repaired or renewed, that part of the system(s) which has been disturbed shall be subjected to a duplicate inspection, with free movement, range, direction and tension checks and shall be certified in accordance with British Civil Airworthiness Requirements, Section A Chapter A6–2 or Section B Chapter B6–2 (A5–3).

11 Fuel System Contamination Checks

The following check must be made to establish that fuel systems are free from contamination:

Fuel system water drain checks are to be carried out at periods not exceeding 24 hours elapsed time and in accordance with Company instruction.

NOTE: The operator must be satisfied with the quality of all fuel taken on board his aircraft, particularly in respect of water contamination and monitor the supplier's quality performance.

12 Portable Valise Type Liferrafts

At the appropriate Overhaul Period ten percent of all liferafts installed in fleets using system bottle and release mechanism are to be inflated and tested. Ensure that deployment and inflation is satisfactory.

13 Area or Zonal Inspection

Where the term 'AREA' or 'ZONAL' is used in this Schedule, this is to be interpreted to mean that a general visual inspection is made for general condition, security and leaks in the structure, systems and components and their installation in the specified zone or area. The inspection must be of sufficient depth to establish that any significant deterioration is identified and rectified to ensure that the general quality/condition of the zone/area is satisfactory until the next higher inspection becomes due.

14 Inspection Standards

- 14.1 Unless otherwise stated, all inspection requirements are to be applied without removing an item from the aircraft or dismantling the item, group or sub-assembly unless dismantling is considered essential in order to ensure airworthiness. Where dismantling is required by this Schedule, this is stated against the item concerned.
- 14.2 All significant terms and abbreviations used within this Schedule to define each maintenance task are defined in accordance with the Type Certificate holder's definitions, current JAR, CAA BCAR definitions or, in the absence of formal definitions, those quoted in World Airlines Technical Operations Glossary.
- 14.3 The inspection standards applied to individual task inspections must meet the requirements of the Type Certificate holder's recommended standards and practices. In the absence of specific manufacturers guidance, refer to this CAP 562 (Civil Aircraft Airworthiness Information and Procedures) or FAA AC 43-13-1A Aircraft Inspection and Repair or other approved data, as appropriate.

15 Condition Monitored Maintenance/Reliability Programme

The method of data collection, analysis, corrective actions and reporting specified for the implementation of this programme is prescribed in the current Document 'CMM/Reliability Programme', which constitutes part of this Approved Maintenance Schedule.

Appendix A

PERMITTED VARIATIONS TO MAINTENANCE PERIODS

- 1 The Operator or their contracted Maintenance Organisation, may vary the periods prescribed by this Schedule provided that such variations are within the limits of subparagraphs a) to e) of this Appendix A.
- 2 Variations shall be permitted only when the periods prescribed by this Schedule (or documents in support of this Schedule) cannot be complied with due to circumstances which could not reasonably have been foreseen by the Operator or by the contracted Maintenance Organisation.
- 3 The decision to vary any of the prescribed periods shall be taken only by the Chief Inspector/Quality Manager or person of equivalent status on behalf of the Operator or the contracted Maintenance Organisation. Particulars of every variation so made shall be entered in the appropriate Log Book(s).

a) Items Controlled by Flying Hours

Period Involved	Maximum Variation of the Prescribed Period
i) 5000 flying hours or less	10%
ii) More than 5000 flying hours	500 flying hours

b) Items Controlled by Calendar Time

Period Involved	Maximum Variation of the Prescribed Period
i) 1 year or less	10% or 1 month, whichever is the lesser
ii) More than 1 year but not 2 months exceeding 3 years	
iii) More than 3 years	3 months

c) Items Controlled by Landing/Cycles

Period Involved	Maximum Variation of the Prescribed Period
i) 500 landings/cycles or less	10% or 25 landings/cycles, whichever is the lesser
ii) More than 500 landings/cycles	10% or 500 landings/cycles, whichever is the lesser

- d) **Items Controlled by More Than One Limit.** For items controlled by more than one limit, e.g. items controlled by flying hours and calendar time or flying hours and landings/cycles, the more restricted limit shall be applied.

- e) **Items Already Subject to CAA Trial Extension Programme.** For an item already subject to an agreed CAA trial extension programme, the trial period may be varied by a maximum of 50 flying hours only provided that such a variation is not specifically excluded by the agreed trial extension programme.

NOTE The variations permitted above do not apply to:

- a) Those components for which an ultimate (scrap) or retirement life has been prescribed (e.g. primary structure of components with limited fatigue lives and high energy rotating parts or which containment is not provided). Details concerning all items of this nature are included in the manufacturer's documents or manuals.
- b) Those periods included in the Maintenance Schedule which have been classified as mandatory by the CAA (see CAP 747 - Mandatory Requirements for Airworthiness).
- c) The Annual Inspection periods for Schedules submitted as alternatives to Schedules Reference CAA/LAMS/FW or CAA/LAMS/H.

Leaflet 5-40 Maintenance of Aircraft not Operated for Commercial Air Transport

1 Introduction

- 1.1 The purpose of this Standard Maintenance Practice is to identify the maintenance requirements for aircraft that are not operated for the purpose of commercial air transport. The maintenance of the aircraft including its engines, propellers and equipment (as applicable) shall be in accordance with the Type Certificate holder’s inspection standards, recommended maintenance programme or schedule and the requirements of this SMP where the manufacturer’s schedules may not encompass the additional maintenance items covered by this SMP.
- 1.2 It is the responsibility of the operator to ensure that this document is completed and submitted to the CAA Regional Office for approval.
- 1.3 The contents of this document shall not be amended without the approval of the Civil Aviation Authority except where changes only affect Appendix B.

2 Maintenance Programme Reference

Manufacturer’s manual reference	Airframe	Engine	Propeller
.....
Revision Status

NOTE: See also Appendix A for equipment etc.

2.1 Maintenance Schedule Applicability

Aircraft type	Aircraft registration(s)	Aircraft serial number(s)
.....
.....

3 Compliance Statement

The contents of this schedule and its associated appendices address the manufacturer’s minimum maintenance requirements for the aircraft listed above.

Organisation/ Person Signature Date
Operator

CAA Use Only

CAA Schedule Approval Reference. MS/..... CAA Stamp

4 Annual Utilisation and Maintenance Review

4.1 In order to meet the requirements of the Air Navigation Order (ANO), British Civil Airworthiness Requirements (BCAR) and Joint Aviation Requirements (JAR) where appropriate, the recommendations made by the manufacturers as amended, have been evaluated and where appropriate are included. It is the duty of the operator or his contracted maintenance organisation to ensure that subsequent maintenance recommendations, including airworthiness information promulgated in Airworthiness Directives, Service Bulletins, Service Letters, Maintenance Manuals, and other regulatory material as issued by the State of Manufacture or the United Kingdom CAA, are evaluated for applicability to this approved schedule.

4.2 **Anticipated annual utilisation (flying hours)/ (flight cycles).**

If the annual utilisation varies by more than 25% from that anticipated, the operator accepts that he, or his contracted maintenance organisation, must review the maintenance tasks and periods with a view to making any necessary adjustments.

NOTE: If the manufacturer produces a special utilisation (e.g. low utilisation) or a schedule based on a specific annual utilisation then this must be used. If this does not align with the anticipated annual utilisation stated above, then the operator accepts that he, or his contracted maintenance organisation, must review the maintenance tasks and periods with a view to making any necessary adjustments.

5 Pre-Flight Inspections

These checks are to be carried out in accordance with the aircraft flight or operations manual, or as specified in the manufacturer's maintenance schedule.

6 Tyre Maintenance

Tyre reliability is dependant on regular checks being carried out. The pre-flight inspection should include a check of the tyres for condition and correct inflation.

NOTE: For large transport aircraft with multi wheel installations see CAP 562 - CAAIP Leaflet B-180 Appendix 32-2.

7 Avionic Installations

7.1 In the absence of the aircraft manufacturer's maintenance requirements for Radio Navigation and Communication equipment, and Radar equipment, an appropriate programme of maintenance shall be included.

7.2 Compass systems will require check swings at periods not exceeding;

- i) for aircraft of 5700 kg MTWA or below, 2 years.
- ii) for aircraft above 5700 kg MTWA, 3 years.

Where the aircraft system uses an inertial reference system which can be used to cross check compass error in flight, this requirement may be varied subject to approval by the CAA.

8 CVR/FDR

Where required by the ANO as amended, or JAR–OPS as appropriate.

- 8.1 Maintain in accordance with the equipment manufacturer's recommendations. In the absence of any specific recommendation the CAA should be contacted for guidance related to the specific installation.
- 8.2 The Operator shall in all cases comply with the requirements of the ANO 2009 (as amended), Article 153(b) by providing a data record for retention purposes every 12 months.

9 Battery Capacity Check

Routine capacity checks should be carried out in accordance with manufacturer's instructions and periods where specified; or the following periods shall apply.

Lead acid Battery – 3 months.
Ni-Cad Battery – 4 months.

10 Safety Equipment

Where the aircraft is required to carry safety equipment this should be checked for serviceability at regular intervals. Overhaul and retirement periods are those specified by the equipment manufacturer.

11 Modifications to Aircraft

- 11.1 Where equipment has been fitted to the aircraft after original manufacture, e.g. autopilots, flight directors etc., the Supplementary Maintenance Appendix A, is required to be amended to take into account the equipment manufacturer's requirements.
- 11.2 Where the aircraft structure has been modified from the original design standard, this must be taken into account when assessing the maintenance requirements.

12 Fatigue Lives and Mandatory Life Limitations (Including Engines)

All fatigue lives and mandatory life limits published by the manufacturer or by the CAA shall be complied with. In the case of foreign products, the CAA may vary the lives published by the manufacturer or itself publish a life, normally as a CAA Additional Airworthiness Directive.

13 Corrosion of Aircraft Structures

Where the manufacturer makes no specific reference to corrosion control programmes, this should be taken into account when inspecting for condition. The assessment may require adjustment of maintenance programme periods. The application of corrosion inhibitors during maintenance may significantly improve the durability of the airframe.

14 Supplementary Maintenance Appendix

The attached Supplementary Maintenance Appendix A, should contain the equipment manufacturer's maintenance requirements, a list of reference material including equipment manuals, service bulletins (SB), STCs, modifications etc. and any life limitations.

The attached Supplementary Maintenance Appendix B, should contain Maintenance Tasks arising from SBs, SLs, and other service information as required by the operator.

15 Certification of Maintenance

15.1 The certificate of release to service for checks carried out in accordance with the manufacturer's programme, should cross refer to the CAA Maintenance Schedule Approval reference number.

15.2 An annual review of the maintenance shall be completed. The review shall as a minimum, include the following items:

1. Confirmation of mandatory modification, ADs and inspection status.
2. Audit of aircraft records.
3. Conformity with CAA approved maintenance schedule.
4. Conformity with CAA approved aircraft radio installation (AC968NR).
5. Review of outstanding deferred defects.
6. Evaluate the effectiveness of the maintenance schedule in addressing the maintenance needs of the aircraft.
7. Review of aircraft and equipment life limits.

15.3 On successful completion of the annual review the following statement shall be made in the Aircraft Log Book.

Annual review carried out in accordance with:

CAA APPROVED MAINTENANCE SCHEDULE REF: _____

Signed: _____ Approved Organisation Ref: _____

This certification shall be made in accordance with the requirements of the AD271, Schedule Approval Document.

16 Permitted Variations to Maintenance Periods

The periods prescribed by the manufacturer may be varied subject to the conditions and limits contained in Appendix C to this SMP.

17 Inspection Standards

17.1 Unless otherwise stated, all inspection requirements are to be applied without removing an item from the aircraft or dismantling the item, group or sub-assembly

unless dismantling is considered essential in order to ensure airworthiness. Where dismantling is required by this Schedule, this is stated against the item concerned.

- 17.2 All significant terms and abbreviations used within this Programme to define each maintenance task are defined in accordance with the Type Certificate holder's definitions, current JAR, CAA BCAR definitions or, in the absence of formal definitions, those quoted in World Airlines Technical Operations Glossary.
- 17.3 The inspection standards applied to individual task inspections must meet the requirements of the Type Certificate holder's recommended standards and practices. In the absence of specific manufacturers guidance, refer to CAA CAP 562 Civil Aircraft Airworthiness Information and Procedures or FAA AC 43-13-1A Aircraft Inspection and Repair or other approved data, as appropriate.

**Supplementary Appendix A
 (Equipment Manufacturer's Maintenance Requirements, Life Limits not covered by the Manufacturer's Maintenance Programme as set out in SMP19 paragraph 2)**

DATE ENTERED	SYSTEM	DETAIL	REFERENCE INFORMATION

Signature of person submitting page

CAA Approval and Date

**Supplementary Appendix B
(Additional Maintenance Required by the Operator in the form of SBs, SLs and other Service Information)**

DATE ENTERED	SYSTEM	DETAIL	REFERENCE INFORMATION

Signature of person submitting page

.....

Supplementary Appendix C

Permitted Variations to Maintenance Periods

- 1 The operator or their contracted Maintenance Organisation, may vary the periods prescribed by this Schedule provided that such variations are not included in the manufacturer's programme within the limits of sub-paragraphs 3 a) to d) of this Appendix C.
- 2 Variations shall be permitted only when the periods prescribed by the manufacturer cannot be complied with due to circumstances which could not reasonably have been foreseen by the Operator or by the contracted Maintenance Organisation.
- 3 The decision to vary any of the prescribed periods with the exception of the Annual Maintenance Review shall be taken only by the Chief Inspector/Quality Manager or person of equivalent status acceptable as a signatory for the prescribed check, on behalf of the Operator or the contracted Maintenance Organisation. Particulars of every variation so made shall be entered in the appropriate Log Book(s).

a) Items Controlled by Flying Hours

Period Involved	Maximum Variation of the Prescribed Period
------------------------	---

- | | |
|----------------------------------|------------------|
| (i) 5000 flying hours or less | 10% |
| (ii) More than 5000 flying hours | 500 flying hours |

b) Items Controlled by Calendar Time

Period Involved	Maximum Variation of the Prescribed Period
------------------------	---

- | | |
|---|---|
| (i) 1 year or less | 10% or 1 month, whichever is the lesser |
| (ii) More than 1 year but not exceeding 3 years | 2 months |
| (iii) More than 3 years | 3 months |

c) Items Controlled by Landing/Cycles

Period Involved	Maximum Variation of the Prescribed Period
------------------------	---

- | | |
|------------------------------------|--|
| (i) 500 landings/cycles or less | 10% or 25 landings/cycles, whichever is the lesser |
| (ii) More than 500 landings/cycles | 10% or 50 landings/cycles, whichever is the lesser |

- d) **Items Controlled by More Than One Limit.** For items controlled by more than one limit, e.g. items controlled by flying hours and calendar time or flying hours and landings/cycles, the more restricted limit shall be applied.

NOTES: 1) CAP 747 - Mandatory Requirements for Airworthiness may override these conditions .

- 2) The variations permitted do not apply to:

Those components for which an ultimate (scrap) or retirement life has been prescribed (e.g. primary structure or components with limited fatigue lives and high energy rotating parts of which containment is not provided). Details concerning all items of this nature are included in the manufacturer's documents or manuals.

INTENTIONALLY LEFT BLANK

Leaflet 5-50 Approval of Maintenance Schedules For Aircraft Above 2730 kg MTWA not Operated for Commercial Air Transport

PURPOSE: This Leaflet is intended to provide guidance material for the compilation of a maintenance schedule for aircraft within the above group.

REFERENCES: CAA Standard Maintenance Practice No. 19.

1 Introduction

- 1.1 The CAA is changing the current Certificate of Airworthiness (C of A) renewal process which has historically required CAA technical staff involvement at the renewal interval. One aspect of this change is that CAA Approved Maintenance Schedules are required for aircraft within this scheme. A principal benefit will be the flexibility of renewing C of As without disrupting the aircraft operation and minimising CAA technical staff effort.
- 1.2 Where the aircraft maintenance schedule is approved by the CAA a recommendation to renew the C of A can be made to CAA by an organisation approved under BCAR A8-3 Supplement No.2. As of 1st April 1995, all aircraft within this group will be required to be maintained to a CAA Approved Maintenance Schedule.
- 1.3 In order to ensure that the Approval process is as simple as possible the procedures assume the use of the manufacturers schedule (as amended), and Standard Maintenance Practice No. 19 (including Appendices A, B and C).

2 Maintenance Schedule Approval Procedure

- 2.1 A copy of Standard Maintenance Practice No. 19 is available in CAP 562 - CAAIP Chapter 5 as Leaflet 5-40 and may be copied for use.
- 2.2 The SMP is formatted with space for details to be added. It can however, be produced and formatted on a word processor providing the intent is not changed. This document will identify the manufacturer's schedule reference and revision status. It must also contain information regarding the aircraft type, serial no., and the registration mark. The CAA will record the aircraft registrations and schedule references. Anticipated annual utilisation is to be stated to enable the operator/contracted maintenance organisation to assess the maintenance periods against the manufacturer's predicted utilisation.
- 2.3 The SMP 19 contains three Appendices:

Appendix A Which should be completed to address supplementary maintenance requirements. This should list, Equipment Manufacturer's Maintenance Requirements, and Life Limits not covered by the Airframe Manufacturer's maintenance programme.

Appendix B Which should be completed to address Maintenance Tasks arising from SBs, SLs and other service information as required by the Operator.

Appendix C Which gives guidance on permitted variations to Maintenance periods.

- 2.4 When SMP 19 has been completed two copies should be submitted to the CAA Airworthiness Evaluation and Surveillance Department Regional Office with a copy of the manufacturer's schedule. The Regional Office will assess the submission and will advise if the manufacturer's schedule is acceptable. Approval of this submission will be signified by the issue of Form AD271, and the allocation of a CAA Approval Reference.
- 2.5 The operator must instigate a formal method of amendment. Any proposed changes to the AD271 or SMP19 shall be submitted to the CAA Airworthiness Evaluation and Surveillance Department Regional Office for approval. Amendments to the manufacturer's programme must be incorporated and advised to the CAA Regional Office, without the need for individual CAA approval.

NOTE: Amendments may be in the form of Service Bulletins issued by the manufacturer prior to full revision of the maintenance programme.

3 Alternative to Manufacturer's Schedule

- 3.1 It is not the CAA's intention to promote the use of an Alternative to the Manufacturers schedule. However, if the operator or his contracted maintenance organisation wishes to use an alternative schedule, than a detailed submission should be made to the CAA setting out the justification for such an alternative and this should be accompanied by suitable substantiation for the revised scheduled maintenance tasks. A fee may be charged for this process.
- 3.2 The schedule with the completed SMP 19 should be sent to the CAA Airworthiness Evaluation and Surveillance Department Regional Office. Once the schedule has been reviewed any comments raised will be communicated to the applicant for corrective action to be taken. When all outstanding items have been addressed, approval will be signified by issue of AD271, and the allocation of a CAA Approval Reference.

4 Alignment Check

Where the aircraft is transferred from one schedule to another, an alignment or bridging check will be required. The extent of the check should be decided by the operator/contracted maintenance organisation following a review of the maintenance carried out to date, but will as a minimum, need to ensure that the requirements of the new schedule have been met.

5 Maintenance Certification

The organisation contracted to carry out maintenance of the aircraft will enter the details of the maintenance carried out in the appropriate Aircraft Log Books and indicate the reference number of the schedule used. This reference number will be shown on the Approval Document AD271. At the time of C of A renewal an annual check in the form of a Maintenance Review is to be carried out. A statement to this effect must be made in the Aircraft Log Book. (Details of this annual check can be found in SMP 19.)

Leaflet 5-60 Condition Monitored Maintenance

1 Introduction

1.1 This Leaflet gives general information on the concepts and practices of aircraft maintenance control by the use of Condition Monitored Maintenance, and is derived directly from Civil Aviation Publication CAP 418. Definitions of the terms and abbreviations used in this Leaflet are given in paragraph 5.

NOTE: Defined terms are given an initial capital letter in the text.

1.2 Confidence in continued airworthiness has long been based on the traditional method of maintaining safety margins by the prescription of fixed component lives and by aircraft 'strip-down' policies. The call for changes to the basic philosophy of aircraft maintenance has been greatly influenced by the present day economic state of the industry as well as by changes in aircraft design philosophy allied to progress in engineering technology. These changes have in turn, resulted in the necessity for the management and control of expensive engineering activities to take a new and more effective form.

1.3 It is from this background that a maintenance process known as Condition Monitoring has evolved. Condition Monitoring is not a separate activity but a complete process which cannot be separated from the complete maintenance programme. It is not just an identification of a single maintenance action but is a basic maintenance philosophy.

1.4 Maximum use can be made of the Condition Monitoring process (which includes a statistical reliability element, see paragraph 3.3), when it is applied to aircraft meeting the following criteria:

a) Modern, multi-engined, Transport Category aircraft which incorporate in their design safeguards against the complete loss of the function which a system is intended to perform.

NOTE: These safeguards are provided by the provision of either Active Redundancy or Standby Redundancy. In simple terms the safeguards take the form of more than one means of accomplishing a given function. Systems (or functions within systems) beyond those necessary for immediate requirements are installed. These are so designed that with an Active Redundancy philosophy all the redundant items are operating simultaneously and, in simple terms, sharing the load to meet the demand. Thus in the event of failure of one of the redundant items, the demand will continue to be met by the remaining serviceable redundant items; this process continues up to the extent of the Redundancy provided. The extent of the Redundancy provided, within practical limits, is related to the consequences of complete loss of the system function. (The term 'multiplicity of system function' is sometimes used in this context). With a Standby Redundancy philosophy only one redundant system is functioning at a time. If a function loss occurs, it is necessary to select (or activate) the functions provided by the 'standby' system(s). The principle is the same as for Active Redundancy and the term 'system redundancy' is sometimes used in this context.

b) Aircraft for which the initial scheduled maintenance programme has been specified by a Maintenance Review Board and to which a Maintenance Steering Group Logic Analysis¹ has been applied.

1. Should fuller details of the current Maintenance Steering Group process, or the process used in respect of a specific aircraft be required, these would have to be obtained from the regulatory authority responsible for the initial certification of that aircraft, or responsible for any subsequent Maintenance Review Board revisions employing a logic process.

NOTE: For an aircraft type introduced into service by Maintenance Review Board and Maintenance Steering Group procedures and where Condition Monitoring tasks are prescribed, a Condition Monitored Maintenance Programme (the Programme) will have to be established, even for a single aircraft.

- 1.5 Items which are not directly controlled by Condition Monitoring may be maintained by the traditional Hard Time or On-Condition processes, but the statistical reliability element of Condition Monitoring may, nevertheless, be applied for the purpose of monitoring their performance (but not be prescribed in the Maintenance Schedule as a primary maintenance process).

NOTE: For a statistical reliability element of a programme to be effectively used, a fleet minimum of five aircraft is normally necessary, but this can vary dependent upon the aircraft type and utilisation.

2 Primary Maintenance

- 2.1 The CAA recognises three primary maintenance processes. They are Hard Time, On-Condition and Condition Monitoring. In general terms, Hard Time and On-Condition both involve actions directly concerned with preventing failure, whereas Condition Monitoring does not. However, the Condition Monitoring process is such that any need for subsequent preventative actions would be generated from the process.

2.2 The Processes

2.2.1 Hard Time

This is a preventative process in which known deterioration of an Item is limited to an acceptable level by the maintenance actions which are carried out at periods related to time in service (e.g. calendar time, number of cycles, number of landings). The prescribed actions normally include Servicing and such other actions as Overhaul, Partial Overhaul, Replacement, in accordance with instructions in the relevant manuals so that the Item concerned is either replaced or restored to such a condition that it can be released for service for a further specified period.

2.2.2 On-Condition

This also is a preventative process but one in which the Item is inspected or tested, at specified periods, to an appropriate standard in order to determine whether it can continue in service (such an inspection or test may reveal a need for Servicing actions). The fundamental purpose of On-Condition is to remove an Item before its failure in service. It is not a philosophy of 'fit until failure' or 'fit and forget it'.

2.2.3 Condition Monitoring

This is not a preventative process, having neither Hard Time nor On-Condition elements, but one in which information on Items gained from operational experience is collected, analysed and interpreted on a continuing basis as a means of implementing corrective procedures.

- 2.3 Where a Maintenance Steering Group Logic Analysis has not been applied to a particular aircraft to establish and allocate the primary maintenance processes for each Item, the considerations of a), b) and c) will be applied separately to all Items to determine the acceptability of the primary maintenance process.

a) Hard Time

- i) Where the failure of the Item has a direct adverse effect on airworthiness and where evidence indicates that the Item is subject to wear or deterioration.

- ii) Where there is a Hidden Function which cannot be checked with the Item in-situ.
 - iii) Where wear or deterioration exists to such an extent as to make a time limit economically desirable.
 - iv) Where component condition or 'life' progression sampling is practised.
 - v) Where limitations are prescribed in a Manufacturer's Warranty.
- b) **On-Condition.** Where an inspection or test of an Item to a prescribed standard (frequently in-situ) will determine the extent of deterioration, and hence the 'condition', i.e. any reduction in failure resistance.
- c) **Condition Monitoring.** Where a failure of an Item does not have a direct adverse effect on operating safety, and where a) and b) are not prescribed and no adverse age reliability relationship has been identified as the result of analysis of the data arising from a formalised monitoring procedure or programme.

3 Condition Monitored Maintenance

3.1 Introduction

Condition Monitored Maintenance, as a programme, is the formalised application of the maintenance processes Hard Time, On-Condition and Condition Monitoring to specific Items as prescribed in the Approved Maintenance Schedule. The controlling activity of Condition Monitored Maintenance is Condition Monitoring irrespective of whether Condition Monitoring is prescribed as a primary maintenance process in the Approved Maintenance Schedule or not. Condition Monitoring is repetitive and continuous, the key factor in its use being the introduction of aircraft embodying failure tolerant designs, which allow for replacement of some traditional failure preventative maintenance techniques by non-preventative techniques. Condition Monitoring is not a relaxation of maintenance standards or of airworthiness control; it is, in fact, more demanding of both management and engineering capabilities than the traditional preventative maintenance approaches. Each Condition Monitored Maintenance Programme is required to be approved by the CAA.

3.2 Maintenance Activities

3.2.1 There are three types of maintenance activity:

- a) Maintenance applied at specified periods of time regardless of condition at that time. The maintenance activity may be a periodic overhaul, a bearing change, re-work, repaint, calibration, lubrication, etc. These result from Hard Time requirements;
- b) Periodic examinations, mostly at specified periods of time, but sometimes on an opportunity basis (e.g. when an Item is removed for access) to determine not only the extent of deterioration but also that the deterioration is within specified limits. These result from On-Condition requirements;
- c) Actions applied in response to the analysis of condition clues produced by monitoring in-flight, hangar, workshop and other types of condition information sources. These result from Condition Monitoring requirements.

3.2.2 Condition Monitoring uses data on failures as items of 'condition' information which are evaluated to establish a necessity for the production or variation of Hard Time and On-Condition requirements, or for other corrective actions to be prescribed. Failure rates and effects are analysed to establish the need for corrective actions. Condition

Monitoring can be used in its own right to identify the effects of deterioration, in order that steps may be taken to maintain the level of reliability inherent in the design of the Item. Although Condition Monitoring accepts that failures will occur, it is necessary to be selective in its application. The acceptance of failures may be governed by the relative unimportance of the function, or by the fact that the function is safeguarded by system Redundancy.

- 3.2.3 Maintenance of a particular Item could well be some combination of the three primary maintenance processes (Hard Time, On-Condition and Condition Monitoring). There is no hierarchy of the three processes; they are applied to the various Items according to need and feasibility. Maintenance Schedules which are based on the Maintenance Steering Group principles will have Hard Time, On-Condition, or Condition Monitoring specified as the primary maintenance process for specific systems and sub-systems as well as for individual Maintenance Significant Items. Condition Monitoring can, therefore, be the primary maintenance process prescribed for an Item, in which case it has also to be used for controlling the availability of those functions which are not directly controlled by a prescribed On-Condition or Hard Time process; this control is provided by the statistical reliability element of Condition Monitored Maintenance. Items for which Hard Time and On-Condition are prescribed may, however, have the statistical reliability element of Condition Monitored Maintenance applied, not as a primary maintenance process, but as a form of Quality Surveillance.

3.3 **Statistical Reliability Element**

- 3.3.1 The assessment of defect/removal/failure rate trend, of age bands at which Items fail, or the probability of survival to a given life are, in most cases, used to measure the effect of suitability of the primary maintenance processes applied to Items. The assessment is made by examination of rates of occurrence of events such as in-flight defects, incidents, delays, use of Redundancy capability, engine unscheduled shut-downs, air turn-backs, etc. which are reported in accordance with the procedure associated with the reliability element of Condition Monitored Maintenance.
- 3.3.2 A statistical reliability programme, as an element of Condition Monitoring, is, in practical terms, the continuous monitoring, recording and analysing of the functioning and condition of aircraft components and systems. The results are then measured or compared against established normal behaviour levels so that the need for corrective action may be assessed and, where necessary, taken.

3.4 **The Condition Monitored Maintenance Programme**

- 3.4.1 A maintenance programme which provides for the application of Hard Time, On-Condition and Condition Monitoring is known as a Condition Monitored Maintenance Programme. A Programme has two basic functions. Firstly, by means of the statistical reliability element, to provide a summary of aircraft fleet reliability and thus reflect the effectiveness of the way in which maintenance is being done. Secondly, to provide significant and timely technical information by which improvement of reliability may be achieved through changes to the Programme or to the practices for implementing it.
- 3.4.2 A properly managed Programme will contribute not only to continuing airworthiness, but also to improvement of fleet reliability, to better long-term planning, and to reduced overall costs.
- 3.4.3 The fundamental factors of a successful Programme are the manner in which it is organised and the continuous monitoring of it by responsible personnel. Because of differences in the size and structure of the various airlines, the organisational side of any Programme is individual to each operator. Hence, it is necessary to detail the organisation and responsibilities in the Programme control documentation.

3.5 **Programme Control Committee**

- 3.5.1 Every Programme is required to have a controlling body (usually known as the Reliability Control Committee) which is responsible for the implementation, decision making and day-to-day running of the Programme. It is essential that the Reliability Control Committee should ensure that the Programme establishes not only close co-operation between all relevant departments and personnel within the Operator's own Organisation, but also liaison with other appropriate Organisations. Lines of communication are to be defined and fully understood by all concerned. The Programme objectives and a typical Organisation and Data Flow Chart are shown in Appendix A.
- 3.5.2 The Reliability Control Committee is responsible for, and will have full authority to take, the necessary actions to implement the objectives and processes defined in the Programme. It is normal for the Quality Manager or the Engineering Manager to head the Committee and to be responsible to the CAA for the operation of the Programme.
- 3.5.3 The formation of the Committee and the titles of members will vary between Operators. The structure and detailed terms of reference of the Committee and its individual members will be fully set out in the documentation for each Programme. The Committee will usually comprise the Quality or Engineering Manager, the Reliability Engineer or Co-ordinator, the Chief Development Engineer, and the Chief Production Engineer.
- 3.5.4 The Committee should meet frequently to review the progress of the Programme and to discuss and, where necessary, resolve current problems. The Committee should also ascertain that appropriate action is being taken, not only in respect of normal running of the Programme, but also in respect of corrective actions.
- 3.5.5 Formal review meetings are held with the CAA at agreed intervals to assess the effectiveness of the Programme. An additional function of the formal review meeting is to consider the policy of, and any proposed changes to, the Programme.

3.6 **Data Collection**

- 3.6.1 Data (or more realistically, collected information) will vary in type according to the needs of each Programme. For example, those parts of the Programme based on data in respect of systems and sub-systems will utilise inputs from reports by pilots, reports on engine unscheduled shut-downs and also, perhaps, reports on mechanical delays and cancellations. Those parts of the Programme based on data in respect of components will generally rely upon inputs from reports on component unscheduled removals and on workshop reports. Some of the larger Programmes embrace both 'systems' and 'component' based data inputs in the fullest of detail.
- 3.6.2 The principle behind the data collection process is that the information to be collected has to be adequate to ensure that any adverse defect rate, trend, or apparent reduction in failure resistance, is quickly identified for specialised attention. Some aircraft systems will function acceptably after specific component or sub-system failures; reports on such failures in such systems will, nevertheless, act as a source of data which may be used as the basis of action either to prevent the recurrence of such failures, or to control the failure rates.
- 3.6.3 Typical sources of data are reports on delays, in-flight defects, authorised operations with known defects (i.e. equipment inoperative at a level compatible with the Minimum Equipment List), flight incidents and accidents, air turn-backs; the findings of line, hangar and workshop investigations. Other typical sources include reports resulting from On-Condition tasks and in-flight monitoring (Airborne Integrated Data Systems); Service Bulletins; other Operators' experience, etc. The choice of a source

of data, and the processes for data collection, sifting and presentation (either as individual events or as rates of occurrence) should be such as to permit adequate condition assessment to be made relative both to the individual event and to any trend.

3.6.4 **Pilot Reports**

- a) Pilot Reports, more usually known as 'Pireps', are reports of occurrences and malfunctions entered in the aircraft Technical Log by the flight crew for each flight. Pireps are one of the most significant sources of information, since they are a result of operational monitoring by the crew and are thus a direct indication of aircraft reliability as experienced by the flight crew.
- b) It is usual for the Technical Log entries to be routed to the Reliability Section (or Engineer/Co-ordinator) at the end of each day, or at some other agreed interval, whereupon each entry is extracted and recorded as a count against the appropriate system. Pireps are thus monitored on a continuous basis, and at the end of the prescribed reporting period are calculated to a set base as a reliability statistic for comparison with the established Alert Levels (see paragraph 3.8) e.g. Pirep Rate per 1,000 hr, Number of Pireps per 100 departures, etc.
- c) Engine performance monitoring can also be covered by the Pirep process in a Programme. Flight crew monitoring of engine operating conditions is, in many Programmes, a source of data in the same way as reports on system malfunctions.

3.6.5 **Engine Unscheduled Shut-downs**

- a) These are flight crew reports of engine shut-downs and usually include details of the indications and symptoms prior to shut-down. When analysed, these reports provide an overall measure of propulsion system reliability, particularly when coupled with the investigations and records of engine unscheduled removals.
- b) As with Pireps, reports on engine unscheduled shut-downs are calculated to a set base and produced as a reliability statistic at the end of each reporting period. The causes of shutdowns are investigated on a continuing basis, and the findings are routed via the Reliability Section to the Powerplant Development Engineer.

3.6.6 **Aircraft Mechanical Delays and Cancellations**

- a) These are normally daily reports, made by the Operator's line maintenance staff, of delays and cancellations resulting from mechanical defects. Normally each report gives the cause of delay and clearly identifies the system or component in which the defect occurred. The details of any corrective action taken and the period of the delay are also included.
- b) The reports are monitored by the Reliability Section and are classified (usually in Air Transport Association of America, Specification 100 (ATA 100) Chapter sequence), recorded and passed to the appropriate engineering staffs for analysis. At prescribed periods, recorded delays and cancellations for each system are plotted, usually as events per 100 departures.

3.6.7 **Component Unscheduled Removals and Confirmed Failures**

At the end of the prescribed reporting period the unscheduled removals and/or confirmed failure rates for each component are calculated to a base of 1,000 hours flying, or, where relevant, to some other base related to component running hours, cycles, landings, etc.

NOTE: Reports on engine unscheduled removals, as with reports on engine performance monitoring, are also a source of data and are reported as part of the Programme.

- a) **Component Unscheduled Removals.** Every component un-scheduled removal is reported to the section which monitors reliability (the 'Reliability Section') and will normally include the following information:
- i) Identification of component.
 - ii) Precise reason for removal.
 - iii) Aircraft registration and component location.
 - iv) Date and airframe hours/running hours/landings, etc. at removal.
 - v) Component hours since new/repair/overhaul/calibration.

Completed reports are routed daily to the Reliability Section for recording and for continuous monitoring for significant trends and arisings. Components exhibiting abnormal behaviour patterns are brought to the attention of the engineering staff responsible, so that detailed investigations may be made and corrective action may be taken.

b) Component Confirmed Failures

- i) With the exception of self-evident cases, each unscheduled removal report is followed up by a workshop report in which the reported malfunction or defect is confirmed or denied. The report is routed to the Reliability Section. Workshop reports may be compiled from an Operator's own 'in-house' findings and/or from details supplied by component repair/overhaul contractors.
- ii) Where an unscheduled removal is justified the workshop reports will normally include details of the cause of the malfunction or defect, the corrective action taken and, where relevant, a list of replacement items. Many Programmes utilise the same type of report to highlight structural and general aircraft defects found during routine maintenance checks.

3.6.8 Miscellaneous Reports

Dependent upon the formation of individual Programmes, a variety of additional reports may be produced on a routine or non-routine basis. Such reports could range from formal minutes of reliability meetings to reports on the sample stripping of components, and also include special reports which have been requested during the investigation of any Item which has been highlighted by the Programme displays and reports.

3.7 Statistical Reliability Measurement

To assist in the assessment of reliability, Alert Levels are established for the Items which are to be controlled by the Programme. The most commonly used data and units of measurement (Pireps per 1,000 hours, Component Removals/Failures per 1,000 hours, Delays/Cancellations per 100 departures, etc.) have been mentioned in paragraph 3.6. Too much importance should not be placed upon the choice of units of measurement, provided that they are constant throughout the time the Programme runs and are appropriate to the type and frequency of the event. The choice of units of measurement will depend on the type of operation, the preference of the Operator and those required by the equipment manufacturer.

3.8 Reliability Alert Levels

- 3.8.1 A reliability alert level (or equivalent title, e.g. Performance Standard, Control Level, Reliability Index, Upper Limit) hereinafter referred to as an 'Alert Level', is purely an 'indicator' which when exceeded indicates that there has been an apparent deterioration in the normal behaviour pattern of the Item with which it is associated. When an Alert Level is exceeded the appropriate action has to be taken. It is

important to realise that Alert Levels are not minimum acceptable airworthiness levels. When Alert Levels are based on a representative period of safe operation (during which failures may well have occurred) they may be considered as a form of protection against erosion of the design aims of the aircraft in terms of system function availability. In the case of a system designed to a multiple Redundancy philosophy it has been a common misunderstanding that, as Redundancy exists, an increase in failure rate can always be tolerated without corrective action being taken.

3.8.2 Alert Levels can range from 0.00 failure rate per 1,000 hours both for important components and, where failures in service have been extremely rare, to perhaps as many as 70 Pireps per 1,000 hours on a systems basis for ATA 100 Chapter 25 – Equipment/Furnishings, or for 20 removals of passenger entertainment units in a like period.

3.8.3 **Establishing Alert Levels**

- a) Alert Levels should, where possible, be based on the number of events which have occurred during a representative period of safe operation of the aircraft fleet. They should be updated periodically to reflect operating experience, product improvement, changes in procedures, etc.
- b) When establishing Alert Levels based on operating experience, the normal period of operation taken is between 2 and 3 years dependent on fleet size and utilisation. The Alert Levels will usually be so calculated as to be appropriate to events recorded in one-monthly or three-monthly periods of operation. Large fleets will generate sufficient significant information much sooner than small fleets.
- c) Where there is insufficient operating experience, or when a programme for a new aircraft type is being established, the following approaches may be used:
 - i) For a new aircraft type during the first 2 years of operation, all malfunctions should be considered significant and should be investigated, and although Alert Levels may not be in use, Programme data will still be accumulated for future use;
 - ii) For an established aircraft type with a new Operator, the experience of other Operators may be utilised until the new Operator has himself accumulated a sufficient period of his own experience. Alternatively, experience gained from operation of a similar aircraft model may be used;
 - iii) A recent concept to be applied in setting Alert Levels for the latest aircraft designs, is to use computed values based on the degree of system and component in-service expected reliability assumed in the design of the aircraft. These computed values are normally quoted in terms of Mean Time Between Unscheduled Removal (MTBUR) or Mean Time Between Failure (MTBF) for both individual components and complete systems. Although these levels tend to be theoretical, they are, of course, based on a considerable amount of testing and environmental engineering and design analysis. Being purely initial predictions they should be replaced when sufficient in-service experience has been accumulated.
- d) There are several recognised methods of calculating Alert Levels, any one of which may be used provided that the method chosen is fully defined in the Operator's Programme documentation.
- e) Typical acceptable procedures for establishing Alert Levels are described briefly in paragraphs i) to iii), and some detailed examples of the methods of calculation are shown in Appendix B. It will be seen that the resultant Alert Levels can vary

according to the method of calculation, but this need not necessarily be considered to be of significance.

- i) **Pilot Reports (Pireps).** For the following example calculations, a minimum of twelve-months' operating data has to be available, and the resultant Alert Level per 1,000 hours is:

Calculation 1. The three-monthly running average Pirep rate per 1,000 hours for each system (or sub-system), as in the Table of Example 1, is averaged over the sample operating period and is known as the Mean; the Mean is multiplied by 1.30 to produce the Level Alert for the given system. This is sometimes known as the '1.3 Mean' or '1.3 \bar{x} ' method.

Calculation 2. The Mean, as in Calculation 1, plus 3 Standard Deviations of the Mean (as illustrated in Appendix B – Example 1).

Calculation 3. The Mean, as in Calculation 1, plus the Standard Deviation of the 'Mean of the Means', plus 3 Standard Deviations of the Mean (as illustrated in Appendix B – Example 2).

- ii) **Component Unscheduled Removals.** For the following example calculations, a minimum period of seven quarters' (21 months') operating data has to be available, and the resultant Alert Level rate for the current quarter may be set in accordance with any one of the following:

Calculation 4. The Mean of the individual quarterly Component Unscheduled Removal rates for the period of seven quarters, plus 2 Standard Deviations of the Mean.

Calculation 5. The maximum acceptable number of 'Expected Component Unscheduled Removals' in a given quarter, as calculated using a statistical process in association with the Poisson Distribution of Cumulative Probabilities (as illustrated in Appendix B – Example 3).

Calculation 6. The Number of 'predicted Component Unscheduled Removals (or failures)' in a given quarter, as determined by the Weibull or other suitable statistical method.

- iii) **Component Confirmed Failures.** The period of operating experience has to be as in ii) and the resultant Alert Level rate for the current quarter is the 'corrected' Mean of the individual quarterly Component Confirmed Failure rates for the period, plus 1 Standard Deviation of the Mean (as illustrated in Appendix B – Example 4).

3.9 Re-calculation of Alert Levels

- a) Both the method used for establishing an Alert Level, and the associated qualifying period, apply also when the level is re-calculated to reflect current operating experience. However, if, during the period between re-calculation of Alert Levels, a significant change in the reliability of an Item is experienced which may be related to the introduction of a known action (e.g. modification, changes in maintenance or operating procedures) then the Alert Level applicable to the Item would be re-assessed and revised on the data subsequent to the change.
- b) All changes in Alert Levels are normally required to be approved by the CAA and the procedures, periods and conditions for re-calculation are required to be defined in each Programme.

3.10 Programme Information Displays and Reports

3.10.1 General

As soon as possible after the end of each defined reporting period of a Programme, the Operator is required to produce graphical and/or tabular displays. These displays have to reflect the fleet operating experience for the period under review. The compilation and production of these displays from the day-to-day records has to be such that the essential information for each Item is in accordance with the requirements of the Programme.

3.10.2 The main purpose of displaying the information is to provide the Operator and the CAA with an indication of aircraft fleet reliability in such a manner that the necessity for corrective actions may be assessed. The format, frequency of preparation and the distribution of displays and reports are fully detailed in the Programme documentation. Typical data displays are described in paragraphs 3.10.3 to 3.10.9 and some examples are illustrated in Appendix C.

3.10.3 Fleet Reliability Summary

This display (see Appendix C, Figure C1), which is related to all aircraft of the same type in the fleet, is usually produced in tabular form, and should contain the following minimum information for the defined reporting period:

- a) Number of aircraft in fleet;
- b) Number of aircraft in service;
- c) Number of operating days (less checks);
- d) Total number of flying hours;
- e) Average daily utilisation per aircraft;
- f) Average flight duration;
- g) Total number of landings;
- h) Total number of delays/cancellations;
- i) Technical Incidents.

3.10.4 Aircraft Mechanical Delays/Cancellations

The purpose of this type of display is to indicate the aircraft systems which have caused delay to or cancellation of flights as a result of mechanical malfunctions. It is normal for each display to show the delays/cancellations as a total for all systems (to represent fleet overall reliability, as in Appendix C, Figure C2) as well as separately for the individual systems. The displays for the separate systems will usually show the delay/cancellation rate for the defined reporting period, the three-monthly moving average rate and, where appropriate, the Alert Level, and will present the information for a minimum period of 12 months.

3.10.5 Engine Unscheduled Shut-downs

This display (see Appendix C, Figure C3) is the prime indication of engine in-service reliability and also, to a large degree, of total powerplant reliability. Because of the high level of reliability of engines and the consequently relatively low numbers of unscheduled shut-downs per fleet, both the actual number of shut-downs and the shut-down rate per 1,000 hours for the defined reporting period as a three monthly running average, shown as a graphical display, will provide useful information in addition to that of Appendix C, Figure C3. To be of most use, where dealing with small

numbers of unscheduled shut-downs, it is usual to present both types of information in such a way as to show the trend over a two-to-three-year period.

3.10.6 **Engine Unscheduled Removals**

This display is the supporting primary indication of engine reliability and is usually presented in a similar manner to unscheduled shut-downs. Many Operators show scheduled and unscheduled engine removals and unscheduled shut-downs on the same display; this is purely a matter of preference (see Appendix C, Figure C3).

3.10.7 **Pilot Reports (Pireps)**

Pireps are presented by system or sub-system (normally identified in accordance with the classifications in ATA 100) in graphical and/or tabular form as a count, or rate, per 1,000 flight hours or 100 departures for the defined reporting period, for comparison with the Alert Level (see Appendix C, Figure C5). Occasionally some Programmes include a Pirep presentation of Fleet Pilot Reports (see Appendix C, Figure C4). This presentation shows the total number of Pireps for all systems and sub-systems and thus gives an overall picture of the total Pireps for the fleet of one aircraft type.

3.10.8 **Component Unscheduled Removals and Confirmed Failures**

- a) There are various methods of displaying component information (both graphically and tabular). The display may be on the basis of each individual component which has been prematurely removed (see Appendix C, Figure C6), or on the basis of the total number of affected components per system (see Appendix C, Figure C7). Experience has shown that a tabular presentation of unscheduled removals and confirmed failures on an individual component basis, preferably giving both numbers and rates per 1,000 hours, of the defined reporting period is the most useful.
- b) The format of any display of component information should be such that:
 - i) Both unscheduled removals and confirmed failure rates may be compared with the Alert Levels so as to identify when the Levels are likely to be exceeded.
 - ii) Current and past periods of operation may be compared.

3.10.9 **Workshop Reports**

A summary of the results of defect investigations, based on the Workshop Reports (see Appendix C, Figure C8) is normally produced by component type for assessment by the Reliability Committee.

3.11 **Problem Identification**

Having collected the information, and having presented it in a timely manner it should now be possible to identify any problems and to assess the necessity for corrective actions. The information, having been sifted and categorised (normally in ATA 100 Chapter order) as individual events and/or rates of occurrence, can be analysed using engineering and/or statistical methods. The analysis can be made at various stages in the handling of the data to differing degrees. Initially, reports on flight defects, delay causes, engine unscheduled shut-downs, workshop and hangar findings, other operators' experience, etc. should be analysed individually to see if any immediate action is desirable. This initial individual analysis will highlight any need for immediate short term actions, e.g. the preparation of Mandatory Occurrence Reports, safety reports, fleet campaigns, with the long term corrective actions following after the later, collective, stages of analysis.

3.12 **Corrective Action**

- 3.12.1 The effectiveness of corrective action will normally be monitored by the very process which revealed the need for it – the Condition Monitoring process.
- 3.12.2 Corrective actions taken to improve the reliability of systems and components, and ultimately that of the fleet, will vary considerably and may typically include one or more of the following:
- a) Changes in operational procedures or improvements in fault-finding techniques;
 - b) Changes to the scope and frequency of maintenance processes which may involve Servicing and inspection, system Tests or Checks, Overhaul, Partial Overhaul or bench testing or the introduction or variation of time limits, etc;
 - c) Modification action;
 - d) Non-routine inspections or adjustment;
 - e) Change of materials, fuels and lubricants;
 - f) Use of different repair agencies;
 - g) Use of different sources of spares;
 - h) Variations of storage conditions;
 - i) Improvements in standards of staff training and technical literature;
 - j) Amendments to the policy/procedures of the Programme.

3.13 **Threshold Sampling**

- 3.13.1 Threshold sampling is the process whereby a maintenance limitation prescribed in the Maintenance Schedule (e.g. Hard Time) is varied in the light of experience gained from any source (e.g. scheduled and unscheduled maintenance, unscheduled removals). The prescribed maintenance limitation is the 'threshold upper limit', and, dependent upon the experience gained, can be either substantiated or varied. Maintenance activities (e.g. time for removal, extent of restoration) are normally related to actual experience of the Item in service (known as 'the experience age band'). When it is considered that the prescribed maintenance activity may be varied, threshold sampling may be used as a means of establishing confidence in the proposal. If when the threshold upper limit is reached, the condition of the Item is such that a variation is justified, then a new threshold upper limit may be set.
- 3.13.2 In setting the number of samples and any other qualifying conditions, both engineering assessment of the design and service experience are taken into account. Evidence derived from other activities (e.g. unscheduled removals or removals scheduled for other purposes) will supplement scheduled sampling and the removal itself may, if representative, be substituted for a scheduled sampling removal.
- 3.13.3 When the optimum period for a particular workshop activity has been determined, threshold sampling will be discontinued and a Hard Time limitation for workshop activity (e.g. Overhaul) will be prescribed.
- 3.13.4 A typical example of the use of threshold sampling is the control of the 'release for service' periods of certain gas-turbine engines, where some of the units on the engines are subject to individual Hard Time limitations (e.g. turbine disc lives, refurbishing intervals). These individual limitations are, in most cases, established and varied by the process described in paragraphs 3.13.1 to 3.13.3. The outcome is that the engine release period for installation in the aircraft is then fixed by the expiration of the lowest unit Hard Time limitation.

3.14 **Quality Management**

3.14.1 With the major issues of airworthiness and the economical allocation of vast sums of money being involved, it is essential that Quality Control should be applied as an overall control of the Maintenance Programme. Each Programme will describe the managerial responsibilities and procedures for continuous monitoring of the Programme at progressive and fixed periods. Reviews, to assess the effectiveness of the Programme, will also be prescribed.

3.14.2 There are various methods, both engineering and statistical, by which the effectiveness of the Programme may be evaluated, and these include:

- a) an assessment of the Programme Document (see paragraph 4) and any subsequent amendment (e.g. with a view to possible extra activities);
- b) surveillance of the Programme activities by the Quality Management Departments;
- c) review by the Programme Control Committee to confirm that corrective action taken are correctly related to the performance trends and to the reports produced;

NOTE: Generally there would be two levels of committee activity, functional and managerial; the functional activity covering the practicality of corrective actions, and the managerial activity covering the overall Quality management of the Programme.

- d) Assessment of reports on incidents and accidents, as these could be potential criticisms of the effectiveness of the Programme.

3.15 **Review of the Programme**

It is normal for each Operator to review the effectiveness of his Programme, in conjunction with the CAA, at annual intervals. At this review consideration will be given to any proposed major changes in the Programme structure and policy so as to obtain the optimum benefits from the operation of the Programme.

4 The Programme Document

4.1 **Approval**

Approval of the Programme (as identified by the 'Document') will depend on the results of an assessment as to whether or not the stated objectives can be achieved. The approval of the Document then becomes a recognition of the potential ability of the Organisation to achieve the stated objectives of the Programme.

NOTE: The Quality Department of the Organisation, together with the CAA, monitors both the performance of the Programme in practice as well as its continuing effectiveness in achieving the stated objectives.

4.2 **Essential Qualities of the Programme**

Condition Monitored Maintenance Programmes can vary from the very simple to the very complex, and thus it is impractical to describe their content in detail. However, the Document has to be such that the considerations in a) to i) are adequately covered.

- a) It generates a precise, specific and logical Quality assessment by the Operator of the ability of the Organisation to achieve the stated objectives.
- b) It enables the CAA initially to accept, and, with subsequent continued monitoring, to have confidence in, the ability of the Organisation to such an extent that the CAA can renew Certificates of Airworthiness, approve changes to the maintenance schedules, etc. in accordance with evidence showing that the objectives of the Programme are being achieved.

- c) It ensures that the Operator provides himself with Quality management of his Organisation.
- d) It provides the Operator with a basis for the discharge of his moral and legal obligations in respect of the operation of aircraft.
- e) It enables the CAA (as the Airworthiness Authority) to discharge its duties and legal obligations in respect of the maintenance aspects of airworthiness, and, where applicable, to delegate certain tasks to the Operator.
- f) The manner of presentation has to be acceptable to the CAA.
- g) With a) to f) in mind, it states the objectives of the Programme as precisely as is possible, e.g. 'maintenance of designated components by reliability management in place of routine overhaul', 'Condition Monitoring as a primary maintenance process'.
- h) The depth of description of the details of the Programme is such that:
 - i) The details can be understood by a technically qualified person.
 - ii) Those factors which require formal CAA acceptance of any changes are clearly indicated.
 - iii) All significant non-self-evident terms are defined.
- i) In respect of individuals or departments within the Organisation:
 - i) The responsibility for the management of the Document, and
 - ii) The procedures for revision of the Document, are clearly stated.

4.3 **Compliance with BCAR**

- a) The Document is required to contain at least the information prescribed in BCAR Section A, Chapter A6–2, Appendix No. 1.
- b) The Document may either be physically contained within the Approved Maintenance Schedule, or be identified in the Approved Maintenance Schedule by reference and issue number, in such a manner that the Approved Maintenance Schedule could be deemed to contain it by specific statement and cross-reference.

4.4 **Assessment of Programme Document**

The following questions (not necessarily definitive) may assist in making a preliminary assessment of the adequacy of the Programme Document:

- a) Is the Document to be physically contained within the Approved Maintenance Schedule? If it is to be a separate document, is it satisfactorily linked with, and identified within the Approved Maintenance Schedule?
- b) Are the objectives of the Programme clearly defined? e.g. 'Maintenance of designated Items by reliability management in place of routine overhaul', 'Confidence assessment of overhaul periods', 'Condition monitoring as a primary maintenance process', 'Airworthiness/economic Quality management of maintenance'.
- c) Does the Approved Maintenance Schedule clearly state to which Items the Programme is applicable?
- d) Is there a glossary of terms associated with the Programme?
- e) What types of data are to be collected? How? By whom? When? How is this information to be sifted, grouped, transmitted and displayed?

- f) What reports/displays are provided? By whom? To whom? When? How soon following data collection? How are delays in publishing controlled?
- g) How is all information and data analysed and interpreted to identify aircraft actual and potential condition? By whom? When?
- h) Is there provision within the Organisation for implementation of corrective actions and is this identified within the Document? How are implementation time periods, effects and time for effect manifestation provided for?
- i) Is there a requirement that the Approved Maintenance Schedule be amended, and is the method of doing so included in the Programme, e.g. variation of time limitations, additional checks?
- j) Is there a requirement that Maintenance Manuals be amended, and is the method of doing so included in the Programme, e.g. maintenance practices, tools and equipment, materials?
- k) Is there a requirement that the Operations Manual/Crew Manual be amended, and is the method of doing so included in the Programme, e.g. crew drills, check lists, defect reporting?
- l) What provision is made for corrective action follow-up and for checks on compliance with original intention, e.g. those which are not working out in practice, spares provisioning, timetables for the incorporation of modifications?
- m) Who is responsible for the management of the Document?
- n) Is there a diagram of the relationship between the departments and groups concerned with the Programme and does it show the flow of Condition Monitoring data, its handling and the prescribed reaction to it?
- o) Are all of the departments involved in the Programme included and are there any responsibilities not allocated?
- p) What Quality management processes are contained within the Programme in respect of:
 - i) Responsibility for the Document itself and the procedure for its amendment?
 - ii) Monitoring of the performance of the Programme by statistical reliability and other methods?
 - iii) Committee consideration of Programme implementation and monitoring of performance?
 - iv) Consideration of reports on incidents and accidents and other events which can effect airworthiness?
 - v) Programme management and discipline?

5 Defined Terms and Abbreviations

5.1 Introduction

Those terms and abbreviations in the text which have a specific meaning are defined in this paragraph 5.

5.2 Terms and Abbreviations

5.2.1 Analysis

The MSG Logic Analysis.

5.2.2 **ATA 100**

Air Transport Association of America, Specification 100.

5.2.3 **Check**

An examination to determine the functional capability or physical integrity of an Item.

5.2.4 **Condition Monitoring**

A primary maintenance process under which data on the whole population of specified items in service is analysed to indicate whether some allocation of technical resources is required. Not a preventive maintenance process, condition monitored maintenance allows failures to occur, and relies upon analysis of operating experience information to indicate the need for appropriate action.

NOTE: Failure modes of condition monitored items do not have a direct adverse effect on operating safety.

5.2.5 **Document**

The Condition Monitored Maintenance Programme document.

5.2.6 **Failure Mode**

The way in which the failure of an Item occurs.

5.2.7 **Hard Time Limit**

A maximum interval for performing maintenance tasks. This interval can apply to Overhaul of an Item, and also to removal following the expiration of life of an Item.

5.2.8 **Hidden Function**

An Item is considered to have a 'hidden function' if either of the following is applicable:

- a) The Item has a function which is normally active whenever the system is in use, but there is no indication to the flight crew when that function ceases.
- b) The Item has a function which is normally inactive, but there is no prior indication to the flight crew that the function will not be available when required.

5.2.9 **Item**

Any level of hardware assembly (i.e. part, sub-system, system, accessory, component, unit, material, portion of structure, etc.).

5.2.10 **Maintenance Significant Items**

Maintenance items that are judged to be relatively the most important from a safety, reliability or economic stand-point.

5.2.11 **Minimum Equipment List**

An approved list of Items which may be inoperative for flight under specified conditions.

5.2.12 **On-Condition/On-Condition Maintenance**

A primary maintenance process having repetitive inspections or tests to determine the condition of units, systems, or portions of structure with regard to continued serviceability (corrective action is taken when required by Item condition).

5.2.13 **Overhaul**

The restoration of an Item in accordance with the instructions defined in the relevant manual.

5.2.14 Partial Overhaul

The overhaul of a sub-assembly of an Item with a time controlled overhaul to permit the longer-lived Item to achieve its authorised overhaul life.

5.2.15 Pireps

Pilot Reports.

5.2.16 Programme

Condition Monitored Maintenance Programme.

5.2.17 Quality

The totality of features and characteristics of a product or service that bear on its ability to satisfy a given need.

5.2.18 Quality Control

A system of programming and co-ordinating the efforts of the various groups in an organisation to maintain or improve quality, at an economical level which allows for customer satisfaction.

5.2.19 Quality Surveillance

Supervision by the customer, his representative, or an independent organisation of a contractor's quality control organisation and methods.

5.2.20 Redundancy

The existence of more than one means of accomplishing a given function. Each means of accomplishing the function need not necessarily be identical.

5.2.21 Redundancy, Active

That redundancy wherein all redundant Items are operating simultaneously rather than being activated when needed.

5.2.22 Redundancy, Standby

That redundancy wherein the alternative means of performing the function is inoperative until needed and is activated upon failure of the primary means of performing the function.

5.2.23 Replace

The action whereby an item is removed and another item is installed in its place for any reason.

5.2.24 Scheduled Maintenance

That maintenance performed at defined intervals to retain an item in a serviceable condition by systematic inspection, detection, replacement of wearout items, adjustment, calibration, cleaning, etc. Also known as 'Preventative Maintenance' and 'Routine Maintenance'.

5.2.25 Servicing

The replenishment of consumables needed to keep an Item or aircraft in operating condition.

5.2.26 Test

An examination of an item in order to ensure that the Item meets specified requirements.

APPENDIX A

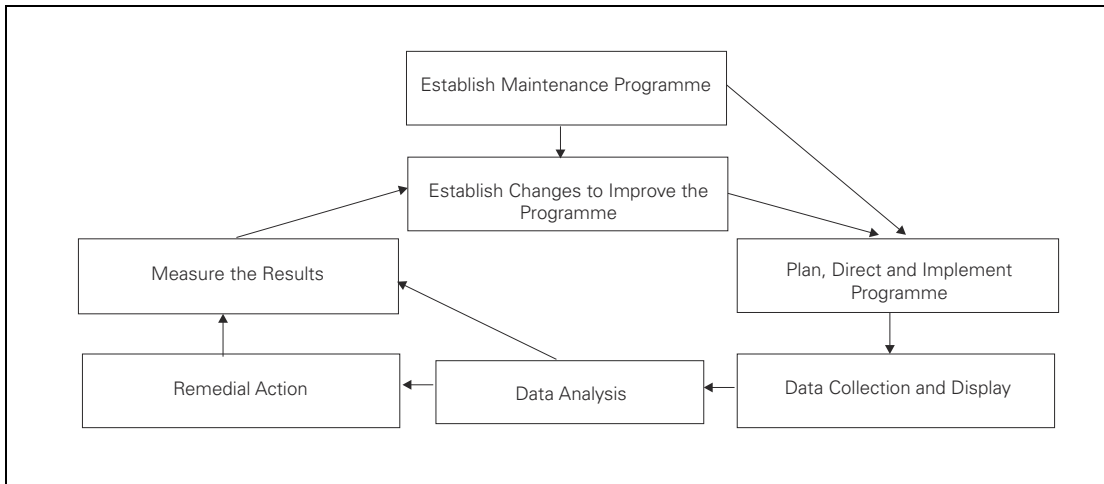

Figure A1 Programme Objectives

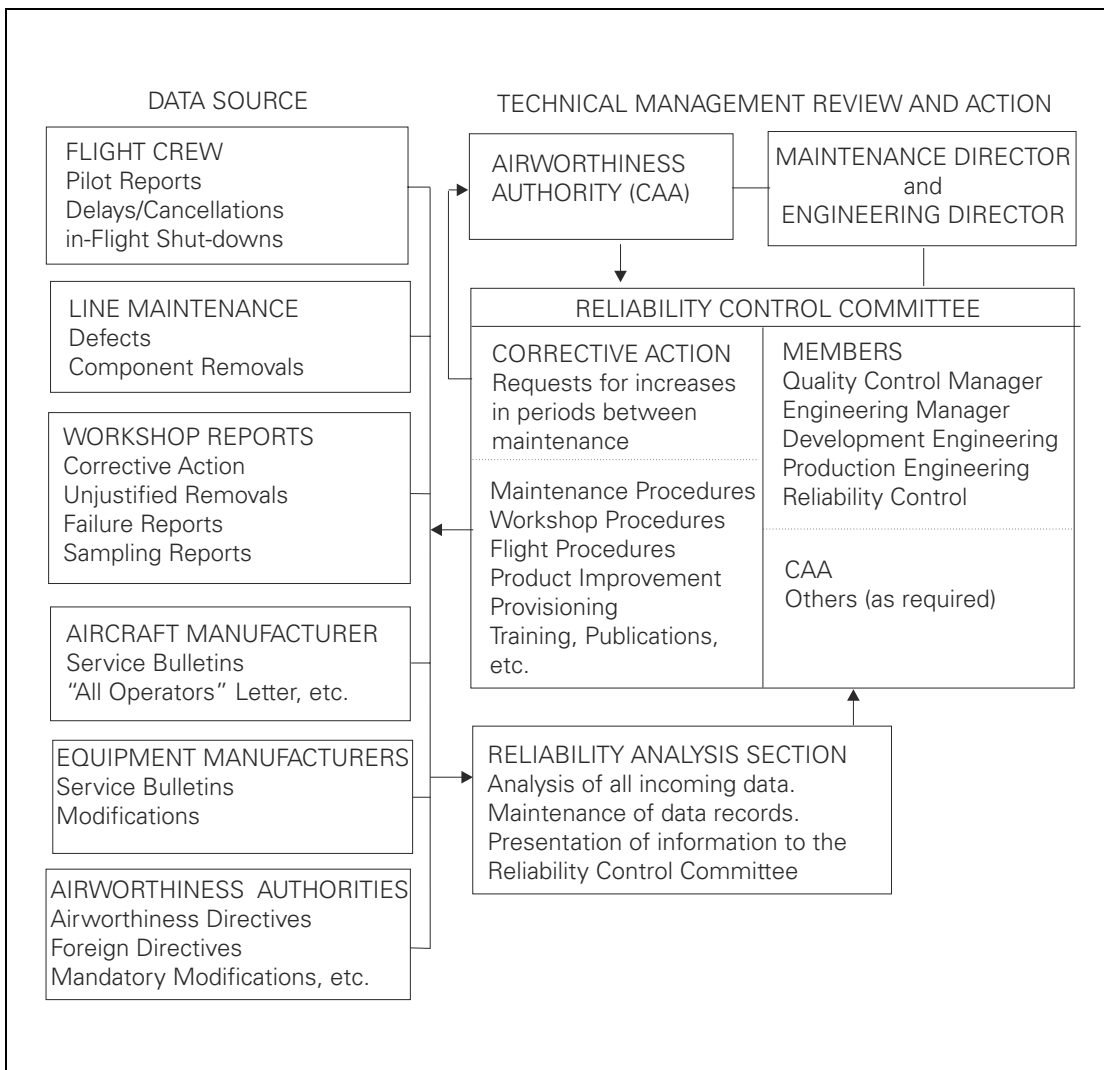

Figure A2 Typical Organisation and Data Flow Chart

APPENDIX B – Alert Level Calculations

Example 1 – Pilot Reports (Pireps) by Aircraft System per 1,000 Flight Hours

Method: Alert Level per 1,000 flight hours = Mean of the 3 monthly Running Average 'Pirep' Rates per 1,000 flight hours (for past 12 months) plus 3 Standard Deviations.

Table 1 System: Aircraft Fuel System (ATA 100, Chapter 28)

Month	Pireps (monthly)	Pireps (3 months cumulative totals)	Flight Hours (monthly)	Flight Hours (3 months cumulative totals)	Pirep Rate per 1,000 hr (3 months running average) (x)
Nov	42	–	2,400	–	–
Dec	31	–	2,320	–	–
Jan	58	131	2,350	7,070	18
Feb	46	135	2,300	6,970	19
Mar	58	162	2,560	7,210	22
Apr	26	130	2,600	7,460	17
May	42	126	2,750	7,910	16
Jun	65	133	3,100	8,450	16
Jul	78	185	2,880	8,730	21
Aug	74	217	2,700	8,680	25
Sep	58	210	3,000	8,580	24
Oct	54	186	2,650	8,350	22
Nov	35	147	2,610	8,260	18
Dec	46	135	2,330	7,590	18

N(months)=12
 Σ = Totals

(x)		(x - \bar{x})	(x - \bar{x}) ²
18		-2	4
19		-1	1
22		2	4
17	MEAN(\bar{x}) = $\frac{\Sigma x}{N}$	-3	9
16		-4	16
16		-4	16
21	= $\frac{236}{12}$	1	1
25		5	25
24		4	16
22	= 19.67 (rounded to 20)	2	4
18		-2	4
18		-2	4
$\Sigma x = 236$			$\Sigma(x - \bar{x})^2 = 104$

STANDARD DEVIATION (SD) = $\sqrt{\frac{\Sigma(x - \bar{x})^2}{N}} = \sqrt{\frac{104}{12}} = \sqrt{8.67} = 2.94$

3 SD = 8.82 (rounded to 9)

ALERT LEVEL = Mean + 3 SD = 20 + 9 = 29

Example 2 – Pilot Reports (Pireps) by Aircraft System per 1,000 Flight Hours

Method : Alert Level per 1,000 flight hours = The Mean (as in Example 1), plus the Standard Deviation of the 'Mean of the Means', plus 3 Standard Deviations of the Mean.

Table 2 Aircraft Fuel System (ATA 100, Chapter 28)

Pirep Rate per 1,000 hr - 3 months running Av. (x)	Mean of x (X)	Difference of X from \bar{X} (D)	(D ²)
18			
19	18.5	1.3	1.69
22	20.5	0.7	0.49
17	19.5	0.3	0.09
16	16.5	3.3	10.69
16	16.0	3.8	14.44
21	18.5	1.3	1.69
25	23.0	3.2	10.24
24	24.5	4.7	22.09
22	23.0	3.2	10.24
18	20.0	0.2	0.04
18	18.0	1.7	2.89
	218.0 = ΣX	23.7 = ΣD	74.79 = $\Sigma(D^2)$

N (months) now = 11 and thus \bar{X} (the mean of the means) will = $\frac{\Sigma X}{N} = \frac{218}{11} = 19.8$

Σ = Totals

STANDARD DEVIATION OF MEAN OF MEANS

$$= \sqrt{\frac{\Sigma(D^2)}{N} - \left(\frac{\Sigma D}{N}\right)^2} = \sqrt{\frac{74.79}{11} - \left(\frac{23.7}{11}\right)^2} = \sqrt{6.80 - 4.64} = 1.47$$

Therefore ALERT LEVEL = MEAN (\bar{x}) + STANDARD DEVIATION OF MEAN OF MEANS (\bar{X}) + 3 SD
 = 19.67 (as in Example 1) + 1.47 + 8.82 (as in Example 1)
 = 29.96 (rounded to 30)

Example 3 – Component Unscheduled Removals by Individual Components in a Three-Monthly Period

Method : Alert Level = 95% cumulative probability of the Poisson Distribution based on past 21 months experience¹ to provide an Alert Level for use as a three-monthly period of comparison.

a) Component: Auto-pilot Pitch Amplifier

number of components per aircraft,	$n = 1$
number of unscheduled removals in past 21 months,	$N = 62$
fleet utilisation hours in past 21 months,	$H = 36840$
number of component running hours in past 21 months	$T = (n \times H) = 36840$
fleet utilisation hours in current 3 months	$h = 5895$
number of component running hours in current 3 months,	$t = (n \times h) = 5895$
number of unscheduled removals in current 3 months	$x = 12$

$$\text{Mean unscheduled removal rate } \lambda = \frac{N}{T} = 0.00168$$

$$\begin{aligned} \text{Expected number of unscheduled removals} \\ \text{in current month} &= \lambda t \\ &= 0.00168 \times 5895 \\ &= 9.9 \text{ (rounded to 10)} \end{aligned}$$

Referring to Figure B1 by entering the graph at $\lambda t = 10$ the intersection with 0.95 (95% probability) gives the maximum acceptable number of unscheduled component removals (A value) for the 3 month period as 15.

By comparing the current value of $x = 12$ one can see that an 'alert' situation does not exist for this component.

b) Component: Temperature Control Value

$$n = 3, N = 31, H = 36840, t = 3 \times 36840 = 110520, h = 5895, \\ t = 3 \times 5895 = 17685, x = 9$$

$$\lambda = \frac{31}{110520} = 0.00028, \lambda t = 0.00028 \times 17685 = 5.01 \text{ (rounded to 5)}$$

from graph, acceptable a value = 8. Current value of $x = 9$, therefore Alert Level is exceeded.

1. For large fleets the past twelve months experience may be used with a one-monthly period of comparison.

Probability of Exact Value of A, or Smaller

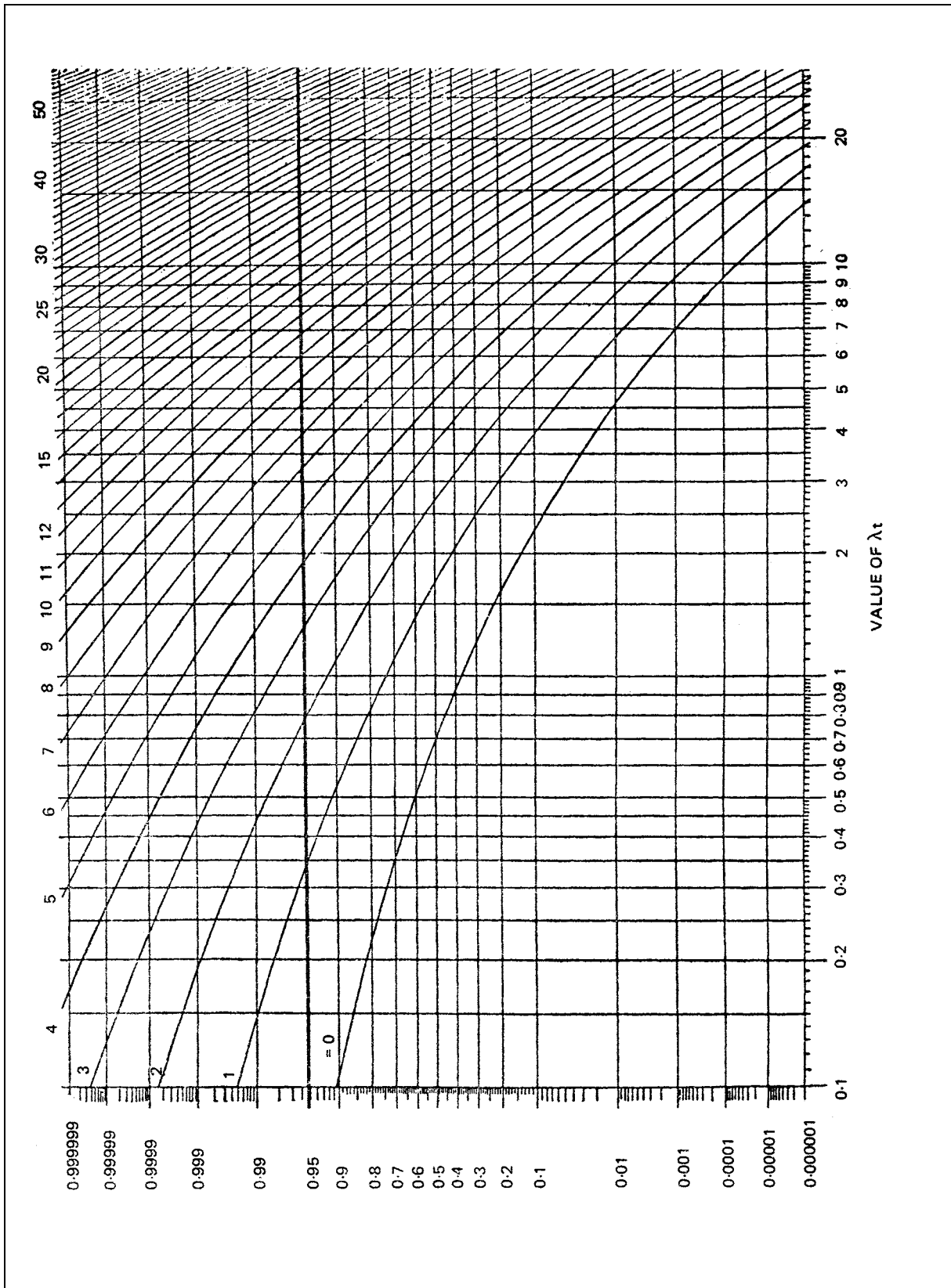

Figure B1 Poisson Cumulative Probabilities

Example 4 – Component Confirmed Failures by Individual Components in a Three-Monthly Period

Method: Alert Level = The 'corrected' Mean of the Quarterly Failure Rates plus 1 Standard Deviation of this mean, based on past seven calendar quarters of confirmed component failure rates per 1,000 hours to provide an Alert Level for use as a quarterly period of comparison.

Component: Main Generator

Table 3 Component Main Generator

Calendar Quarter	Quarterly Failure Rate (u)	Corrected Rate (C)	(C ²)
2/74	0.21	0.63 ¹	0.397
3/74	0.38	0.38	0.144
4/74	0.42	0.42	0.176
1/75	0.84	0.84	0.706
2/75	0.59	0.59	0.348
3/75	0.57	0.57	0.325
4/75	1.38	0.63 ¹	0.397
	4 · 39Σ(u)	4 · 06Σ(C)	2 · 493Σ(C ²)

1

N(months)=7

Σ = Totals

$$\text{QUARTERLY MEAN FAILURE RATE} = \frac{\Sigma(u)}{N} = \frac{4 \cdot 39}{7} = 0 \cdot 63$$

$$\text{CORRECTED MEAN FAILURE RATE } \bar{C} = \frac{\Sigma C}{N} = \frac{4 \cdot 06}{7} = \underline{0 \cdot 58}$$

$$\begin{aligned} \text{STANDARD DEVIATION, SD} &= \sqrt{\frac{\Sigma(C^2) - \frac{(\Sigma(C))^2}{N}}{N - 1}} \\ &= \sqrt{\frac{2 \cdot 493 - \frac{(4 \cdot 06)^2}{7}}{6}} \\ &= \sqrt{\frac{2 \cdot 493 - 2.355}{6}} \\ &= \underline{0 \cdot 15} \end{aligned}$$

$$\text{ALERT LEVEL} = \bar{C} + 1SD = 0 \cdot 58 + 0 \cdot 15 = \underline{0 \cdot 73}$$

1. Where an individual Quarterly Failure Rate falls outside plus or minus 50% of the uncorrected Quarterly Mean Failure Rate (0.63 in this case), then this Mean is to be used as a Corrected Rate in place of the uncorrected Quarterly Failure Rate.

AIRCRAFT TYPE:	1976		1977												ACCUM TOTALS	
			JAN	FEB	MAR	APR	MAY	JUN	JUL	AUG	SEP	OCT	NOV	DEC		
NUMBER OF AIRCRAFT IN FLEET	6		6	6	6	6	6	6	6	6	6	6	6	6	6	6
NUMBER OF AIRCRAFT IN SERVICE	6		5	5	5	6	6	6	6	6	6	6	6	6	6	6
NO OF OPERATING DAYS (less checks)	1634		153	144	152	160	186	174								969
FLYING HOURS	13400:39		907	801	1068	1374	1571	1798								7519
(hr:min)	39:38		5	4	8	3	0:5	1								21:5
Non Revenue -	97:24		-	24	25	32	12:5	1								94:5
Training -	13537:41		912	828	1102	1409	1584	1800								7635
TOTAL																
DAILY UTILIZATION (average/aircraft) (hr:min)	8:17		5:57	5:45	7:15	8:48	8:31	10:20								7:52
AVERAGE FLIGHT DURATION (hr:min)	2:32		2:52	2:43	2:42	2:36	2:23	2:23								2:36
LANDINGS	5277		316	293	395	528	658	752								2942
Revenue -	45		5	2	2	5	2	3								19
Non Revenue -	275		3	55	100	104	34	4								300
Training -	5597		324	350	497	637	694	759								3261
TOTAL																
TECHNICAL DELAYS -	5277		316	293	395	528	658	752								2942
Number of Movements -	134		8	6	9	17	13	16								69
REVENUE (more than	310:32		38	13	9	27	22	33								142
15 mins)	2:54		2:53	2:04	2:27	3:22	1:97	2:12								2:35
Average Delay (%)			-	-	-	-	-	-								-
TECHNICAL CANCELLATIONS			-	-	-	-	-	-								-
TECHNICAL INCIDENTS	7		Nil	Nil	Nil	Nil	Nil	Nil								Nil
Interrupted Flights -	Nil		Nil	Nil	Nil	Nil	Nil	Nil								Nil
Engine Shut Downs -	Nil		Nil	Nil	Nil	Nil	Nil	Nil								Nil
Fire Warnings -	Nil		Nil	Nil	Nil	Nil	Nil	Nil								Nil
Fire Warnings (false) -	Nil		Nil	Nil	Nil	Nil	Nil	Nil								Nil
Fuel Dumpings -	Nil		Nil	Nil	Nil	Nil	Nil	Nil								Nil
REMARKS																

Figure C1 Fleet Reliability Summary

APPENDIX C - Typical Data Displays

AIRCRAFT TYPE:		1976												1977											
		Average																							
%		JAN	FEB	MAR	APR	MAY	JUNE	JULY	AUG	SEPT	OCT	NOV	DEC	JAN	FEB	MAR	APR	MAY	JUNE	JULY	AUG	SEPT	OCT	NOV	DEC
5																									
4																									
3	3:80																								
2	2:65																								
1	1:98																								
BASE	NO. OF MOVEMENTS	NO. OF TECH. DELAYS			TOTAL DELAY TIME (hr:min)			AVERAGE DELAY (%)			REMARKS														
		JAN	FEB	MAR	JAN	FEB	MAR	JAN	FEB	MAR															
Gatwick	171	159	174	17	4	4*	9:50	7:20	11:35	5:26	2:34	2:29	*1 Overseas												
Manchester	44	46	17	3	3	0	0:30	2:51	-	2:27	6:52	-													
Berlin	127	59	111	3	-	2	13:19	-	4:21	2:36	-	1:80													
TOTALS	342	264	302	13	7	6	23:39	10:11	15:56	3:80	2:65	1:98													

Figure C2 Aircraft Mechanical Delays/Cancellations

AIRCRAFT TYPE: ENGINE TYPE:	1976	1977												ACCUM TOTALS 1977	PREVIOUS 12 MONTHS TOTALS		
		JAN	FEB	MAR	APR	MAY	JUNE	JUL	AUG	SEPT	OCT	NOV	DEC				
		Total Engine Hours	40613	2735	2486	3306	4227	4752	5400								
Total Unscheduled Removals Rate per 1,000 Eng. Hours	4 0.10	- -	- -	- -	- -	0.21	0.18									2 0.08	4 0.08
REASON Failure Suspect Failure External Causes	4 - -	- - -	- - -	- - -	- - -	1 - -	1 - -									2 - -	4 - -
INVEST'N RESULTS Basic Engine Failure Non Basic Engine Failure Substantiated	2 - 1	- - -	- - -	- - -	- - -	- - -	- - -									1 - 1	2 - 2
FOLLOW UP ACTION Rectification H.S.I. ¹ Overhaul	3 - -	- - -	- - -	- - -	- - -	1 - -	- - 1									1 - 1	3 - 1
SCHEDULED REMOVAL Total Scheduled Removals H.S.I. ¹ Time Expired Time Expired - Overhaul - H.S.I. ¹ Approved Life Overhaul Approved Life	4 1 3 5500 10500	2 2 - 5500 10500	2 - 2 ² 5500 10500	1 - 1 5500 10500	1 - - 5500 10500	1 - - 5500 10500	- - - 5500 10500									6 2 3 5500 10500	7 2 5 5500 10500
UNSCHEDULED ENGINE SHUT-DOWN Total Number Rate per 1,000 Hours Accumulative Rate	Nil Nil Nil	Nil Nil Nil	Nil Nil Nil	Nil Nil Nil	Nil Nil Nil	Nil Nil Nil	Nil Nil Nil	Nil Nil Nil	Nil Nil Nil	Nil Nil Nil	Nil Nil Nil	Nil Nil Nil	Nil Nil Nil	Nil Nil Nil	Nil Nil Nil	Nil Nil Nil	Nil Nil Nil

1. Hot Section Inspection
2. 1 removed for disc mod

Figure C3 Engine Removals and Unscheduled Shut-Downs

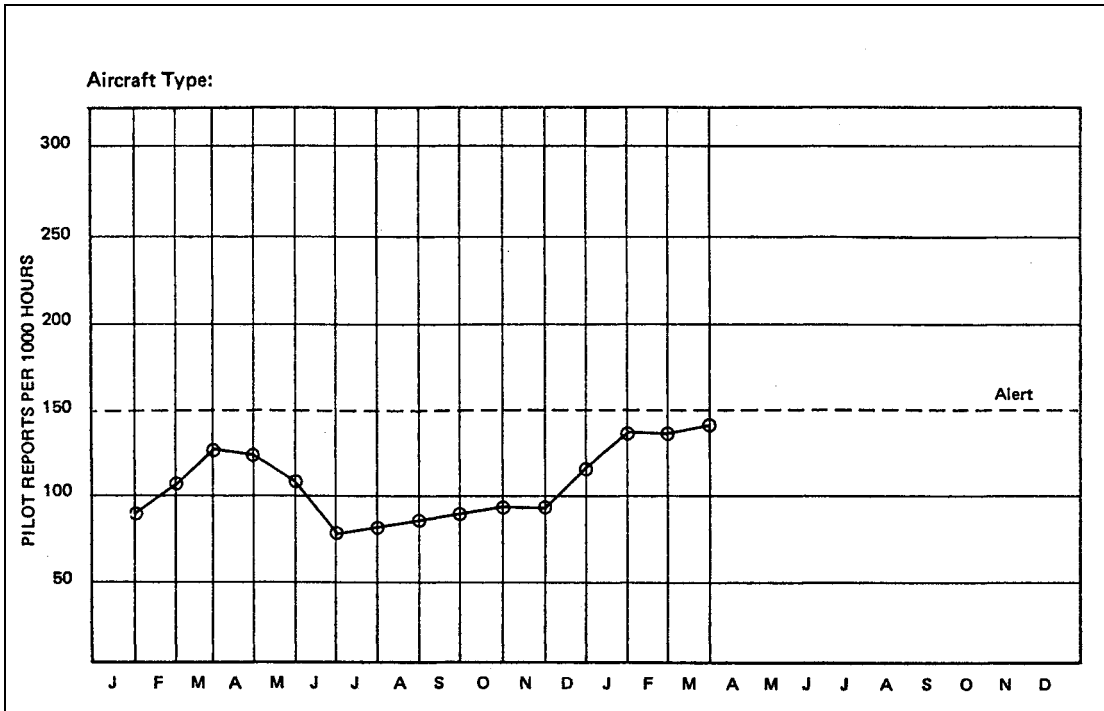

Figure C4 Fleet Pilot Reports

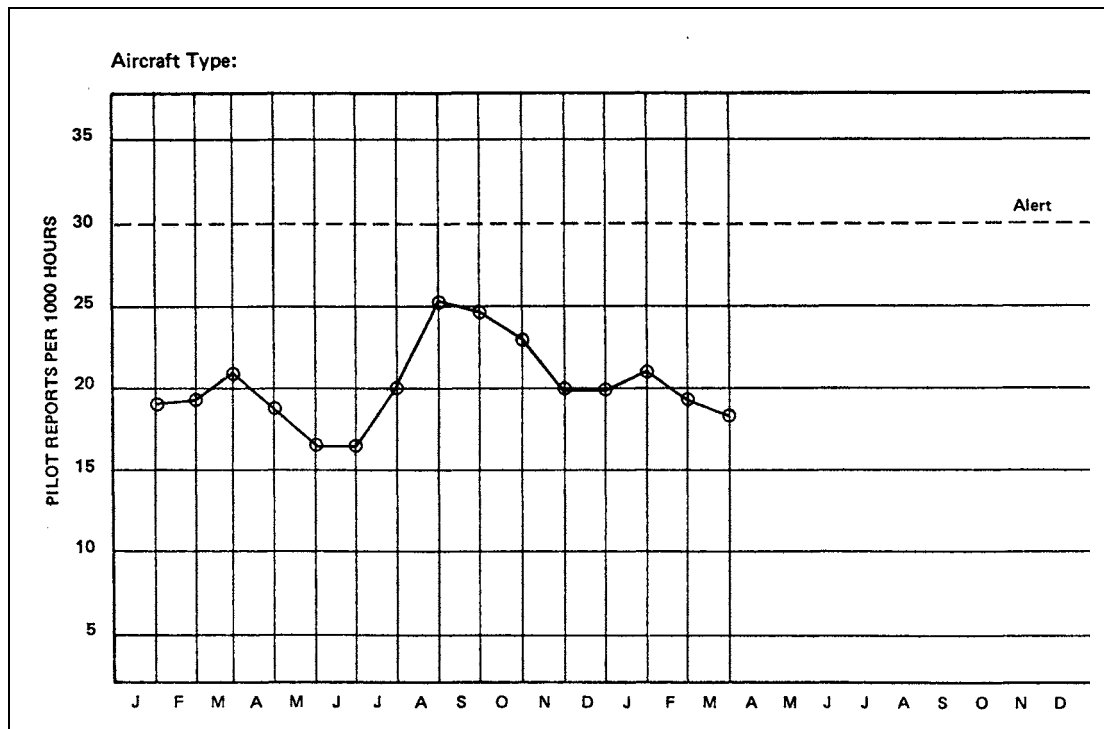

Figure C5 Pilot Reports ATA 21 - Air Conditioning System

AIRCRAFT TYPE: Air Conditioning/Pressurisation (ATA 100 Chapter 21)														
SCH. REF.	PART NUMBER	NO PER A/O	COMPONENT	FLYING HOURS		13408		2495		ALERT LEVEL		ACCUMULATIVE COMPONENT CONFIRMED FAILURES SINCE 1.1.74		
				PERIOD		A*	B*	C*	1ST QTR 1976	A*	B*	C*	A*	B*
30/4	131046-1	1	Manual Pressure Controller			-	-	2	0.80	-	-	2	0.06	16000
30/5	102518-3-1	1	Auto Cabin Pressure Controller			4	0.29	-	-	-	0.60	9	0.28	3555
30/6	10-3280-5-1	2	Cabin Outflow Valve			9	0.26	1	-	1	0.50	9	0.14	7110
51/1	178040-2-1	4	Heat Exchanger			3	0.05	-	-	-	0.15	5	0.04	25601
51/2	204050-10-1	2	Air Cycle Machine			2	0.07	-	-	-	0.30	4	0.06	16000
51/5	129150-2-1	2	35° Thermostat Pack Anti-icing			1	0.03	-	-	-	0.30	1	0.015	64020
51/6	321674-3-1	2	Valve - Pack Shut-Off			5	0.11	2	-	-	0.30	5	0.08	12800
52/2	541248-2-1	2	Actuator - Ram Air			1	0.03	-	-	-	0.30	2	0.03	32000
52/7	207562-1	2	Fan Cooling Pack			2	0.07	-	-	-	0.30	8	0.13	8000
58/3	18801-5	1	Detector - Air Flow Sensor			-	-	-	-	-	-	1	0.03	32000
61/1	321402-1-1	2	Valve/Actuator -Control Mix			-	-	-	-	-	0.30	5	0.08	12809
61/2	548376-5	1	Controller - Air Temp			1	0.07	1	0.20	-	0.60	2	0.06	16000
61/9	67321-10-190	3	Temperature Sensor			-	-	-	-	-	0.15	1	0.01	96061
62/2	163BL501	2	Indicator - Pack Temp.			-	-	-	-	-	0.30	1	0.015	64020
30/7	132322-2-1	1	Fan Venturi			2	0.14	1	0.40	-	0.60	4	0.13	8000
61/3	548392-1-1	2	Cabin Temp. Sensor			1	0.03	-	-	-	0.30	1	0.015	64020
42/1	32-2684-002	1	Cargo Outflow Valve			-	-	1	0.40	-	0.60	2	0.06	16000
58/8	123266-2-1/ } 123544.1.1	2	Hot Air Check Valve			-	-	1	0.20	-	0.30	1	0.015	6402
23/1	500702-4620	2	Gasper Fan			-	-	-	-	-	0.60	4	0.06	16000
51/3	178050-2-1	2	Water Separator			-	-	-	-	-	0.60	2	0.03	32001
51/4	10-60506-4	2	35° Valve Pack Anti-Icing Cont			-	-	-	-	-	0.30	-	-	-

1. MTBF - Mean Time Between Failures

*A - No. of unscheduled removals
*B - Failure Rate per 1,000 hours
*C - Non-confirmed Defects
*X - Failure Rate above Alert Level

Figure C6 Component Unscheduled Removals and Confirmed Failures

AIRCRAFT TYPE:		JANUARY 1971			1970 FIRST HALF			1970 LAST HALF		
ATA 100 CHAPTER	ALERT LEVEL	UR ¹	URR ²	FR ³	UR ¹	URR ²	FR ³	UR ¹	URR ²	FR ³
21 - Air Conditioning	.35	2	.53	.33	14	.34	.32	15	.36	.31
22 - Auto-pilot	.80	4	1.33	.33	16	.98	.29	19	.98	.32
23 - Communications	.92	2	.67	.48	10	.57	.48	8	.56	.37
24 - Electric Power	.20	2	.08	.02	8	.06	.02	9	.07	.03
27 - Flight Controls	.30	1	.20	.09	7	.12	.10	6	.10	.08
28 - Fuel	.23	0	.00	.00	2	.64	<u>.30</u>	1	.09	.06
29 - Hydraulic	.38	1	.42	<u>.40</u>	2	.26	.18	4	.46	.22
30 - Ice & Rain Protection	.15	0	.00	.00	2	.14	.08	2	.14	.08
31 - Instruments	.65	4	.63	.34	20	.61	.31	16	.57	.20
32 - Landing Gear	.33	1	.04	.02	7	.05	.03	9	.09	.04
34 - Navigation	.73	3	.66	.21	20	.69	.24	24	.71	.29
35 - Oxygen	.30	2	.66	<u>.32</u>	11	.65	<u>.31</u>	9	.64	.30
36 - Pneumatic	.20	0	.00	.00	2	.01	.01	4	.02	.02
38 - Water/Waste	.24	1	.09	.06	6	.16	.15	7	.17	.16
49 - APU	.48	1	.33	.32	7	.34	.34	4	.26	.29
73 - Engine Fuel & Control	.39	0	.00	.02	4	.10	.06	2	.06	.05
75 - Engine Air	.28	1	.17	.16	5	.16	.14	3	.12	.12
77 - Engine Indicating	.30	5	.42	.17	26	.46	.18	22	.44	.17
79 - Oil	.22	0	.00	.00	2	.04	.02	3	.06	.04
80 - Starting	.50	1	.17	.11	6	.18	.12	3	.09	.10

Figure C7 Component Unscheduled Removals and Confirmed Failures

1. UR - Unscheduled Removal
2. URR - Unscheduled Removal Rate
3. FR - Confirmed Failure Rate (3 months cum. av.)

AIRCRAFT TYPE:					
SERIAL NO.	AIRCRAFT & POSITION	HRS RUN	DEFECT	RESULTS OF WORKSHOP INVESTIGATION AND ACTION TAKEN	
1170109	G-	848 TSR ¹ 9375 TSN ²	Losing altitude in turns	Test wing levelling not operative; recalibrated.	
0290329	G-	11110 TSR 16771 TSN	Rolls rapidly to right when heading hold engaged.	Various internal outputs were drifting and distorted. Replaced tacho, roll CT and resolver, servo amp and valve amplifier.	
0920575	G-	99 TSR 4014 TSN	Altitude hold sloppy in turns.	Roll computer out of calibration limits. Mod D to Lateral Path Coupler embodied to improve interface between Sxxxx equipment and Cxxxx receiver.	
1280330	G-	36 TSR 7664 TSN	A/C will not maintain heading - ends up with 30° bank.	No fault found but extensive investigation revealed A3A1A2B output 1.5V - should be zero volts.	
CONCLUSIONS			REMEDIAL ACTION		
All channel assemblies are now sent to Manufacturer for investigation. Histories are reviewed and any channels which previous 'NFF' ³ findings are being extensively tested to isolate components which may be drifting out of tolerance. This should result in improved MTBF ⁴ , but will probably show more confirmed failures for a while.					
REPORT REF. NO.		PART NO.		ITEM	
22-10-14/20 Sheet 1 of 1		1Q75-22-2H		2588812-901	
				Roll channel assy.	

Figure C8 Workshop Report

1. Time since repaired
2. Time since new
3. 'No fault found'
4. Mean Time Between Failures

Leaflet 5-70 Aircraft, Engine and Propeller Log Books

1 Introduction

The Air Navigation Order (ANO), prescribes that a separate log book must be kept for each aircraft registered in the United Kingdom, for each engine and for each variable-pitch propeller fitted to such aircraft. The ANO also prescribes the information which must be recorded, the timescales within which the record must be made and the person responsible for keeping the log books. Also included in the ANO are the requirements for the retention of records, and details concerning acts in connection with log books which constitute offences under the Order.

2 Purpose

It is intended that a log book should constitute a history of the aircraft, engine or propeller to which it refers in terms of, as appropriate:

- Manufacturer;
- Date of Manufacture;
- Manufacturers No./Serial No.;
- Aircraft Registration;
- Type;
- Aircraft/engine to which fitted;
- Operator;
- Flying hours/cycles, etc;
- Maintenance;
- Continued compliance with mandatory requirements.

3 Source and Format of Log Books

3.1 For aircraft not exceeding 2730 kg MTWA, the CAA requires that all log books shall be CAA approved. CAA publications CAP 398, 399 and 400 meet this requirement for aircraft, engines and propellers respectively in this category and are intended to comprise a self-contained record of the item to which they refer.

3.2 For aircraft exceeding 2730 kg MTWA, the log book can take any form acceptable to the CAA. CAA publications CAP 388, 391 and 408 are suitable log books for propellers, engines and aircraft respectively in this category.

3.3 Alternative Form of Log Book

To enable acceptance of an alternative technical record system the following features should be taken into account:

- a) Compliance with the requirements of the ANO must be shown;
- b) The record must be kept in indelible hard copy form or in the form of a computer memory acceptably safeguarded against erasure and available when required as a printed-out hard copy;

- c) Any computer system used must be capable of a total quarantine of the record for a particular aircraft, engine or variable-pitch propeller on command and must be capable of a subsequent print-out of data in a form acceptable to the CAA;
- d) Safeguards against erasure of any computer memory must include adequate defences against fraud, malpractice, incompetence and accidents such as power failure. Any erase function must be unavailable once data is committed to the memory;

NOTE: The requirements of Article 231 of the ANO 2009 (as amended) apply to all forms of technical record and must be satisfied.

- e) Any recording system offered for acceptance must be capable of maintaining the required timescale for updating;
- f) On any occasion requiring the transfer of responsibility for the upkeep of a technical record system the form taken by the system must lend itself to removal without loss of content;
- g) In a computer system the information comprising the log book in the terms of the requirements should, when printed out, be in a coherent format and legible to the user without a need for in-depth knowledge of computer language. In addition, to enable the efficient conduct of investigations the required data should, when printed out, preferably be discrete from other data stored in excess of the requirements.

NOTE: Any extension of the log book in the form of files, appendices, subsidiary records held elsewhere such as by Non-Destructive Testing (NDT) specialists or Test Houses are deemed in a legal sense to be part of the subject log book and must be treated accordingly, including the retention of a clear cross-references association with the basic log book.

4 Timescale Limitations for the Upkeep of Records

- 4.1 Apart from those entries shown in paragraph 4.2, each entry should be made as soon as is practicable after the occurrence to which it relates, but in no event more than seven days after the expiry of any Certificate of Maintenance Review (CMR) in force at the time of the subject occurrence. (See BCAR Section A, Chapter A6–2 for information on CMR.)
- 4.2 In engine and variable-pitch propeller log books, where the operator has chosen to record total aggregated flying time accrued since the last issue of a Certificate of Release to Service (CRS), each entry related to flight time must be made on the occasion of any work which will require the issue of the next CRS. (See BCAR Section A, Chapter A6–2 for information on CRS.)
- 4.3 There are aircraft which do not necessarily require a CMR or a CRS by virtue of their Certificate of Airworthiness (C of A) Category and MTWA (see paragraph 5.1.5). The operators of such aircraft should however, bear in mind that the validity of any C of A depends on continued compliance with any applicable Approved Maintenance Schedule and with all applicable mandatory requirements. It follows that a regular review of maintenance and adherence to proper standards are essential even when certifications to that effect are not legally required.

5 Information to be Recorded

5.1 Information which must be Recorded

The following is, in part, quoted from the ANO.

5.1.1 Aircraft Log Book

The following entries shall be included in the aircraft log book:

- a) the name of the manufacturer, the type of the aircraft, the number assigned to it by the manufacturer and the date of the manufacture of the aircraft,
- b) the nationality and registration marks of the aircraft,
- c) the name and address of the operator of the aircraft,
- d) the date of each flight and the duration of the period between take-off and landing, or, if more than one flight was made on that day, the number of flights and the total duration of the periods between take-off and landings on that day,
- e) particulars of all maintenance work carried out on the aircraft or its equipment,
- f) particulars of any defects occurring in the aircraft or in any equipment required to be carried therein by or under the ANO, and of the action taken to rectify such defects including a reference to the relevant entries in the technical log required by the ANO, and
- g) particulars of any overhauls, repairs, replacements and modifications relating to the aircraft or its equipment.

NOTE: Entries are not required to be made under sub-paragraphs e), f) and g) in respect of any engine or variable-pitch propeller (see respectively paragraphs 5.1.2 and 5.1.3).

5.1.2 Engine Log Book

The following entries shall be included in the engine log book:

- a) the name of the manufacturer, the type of the engine, the number assigned to it by the manufacturer and the date of the manufacture of the engine;
- b) the nationality and registration marks of each aircraft in which the engine is fitted;
- c) the name and address of the operator of each such aircraft;
- d) either,
 - i) the date of each flight and the duration of the period between take-off and landing or, if more than one flight was made on that day, the number of flights and the total duration of the periods between take-offs and landings on that day; or
 - ii) the aggregate duration of periods between take-off and landing for all flights made by that aircraft since the immediately preceding occasion that any maintenance, overhaul, repair, replacement, modification or inspection was undertaken on the engine;
- e) particulars of all maintenance work done on the engine;
- f) particulars of any defects occurring in the engine, and of the rectification of such defects, including a reference to the relevant entries in the technical log required by the ANO; and
- g) particulars of all overhauls, repairs, replacements and modifications relating to the engine or any of its accessories.

5.1.3 Variable-Pitch Propeller Log Book

The following entries shall be included in the variable-pitch propeller log book:

- a) the name of the manufacturer, the type of the propeller, the number assigned to it by the manufacturer and the date of the manufacture of the propeller;
- b) the nationality and registration marks of each aircraft, and the type and number of each engine, to which the propeller is fitted;
- c) the name and address of the operator of each such aircraft;
- d) either;
 - i) the date of each flight and the duration of the period between take-off and landing or, if more than one flight was made on that day, the number of flights and the total duration of the periods between take-offs and landings on that day; or
 - ii) the aggregate duration of periods between take-off and landing for all flights made by that aircraft since the immediately preceding occasion that any maintenance, overhaul, repair, replacement, modification or inspection was undertaken on the propeller;
- e) particulars of all maintenance work done on the propeller;
- f) particulars of any defects occurring in the propeller, and of the rectification of such defects, including a reference to the relevant entries in the technical log required by the ANO; and
- g) particulars of any overhauls, repairs, replacements and modifications relating to the propeller.

5.1.4 A clear record of continued compliance with all applicable mandatory requirements is required.

5.1.5 Each record of work done should, when required, be covered by a CRS unless the certification has been made elsewhere, in which case it must be cross-referred to in the log book (BCAR Section A, Chapter A6–7 and Section B, Chapter B6–7 refers). Currently a CRS is required for all types of work except on aircraft in the Special Category not exceeding 2730 kg MTWA, and aircraft in the Special or Private categories of similar weight, when the work done comes within the provisions of the Air Navigation Regulation which specifies work which can be carried out personally by the owner or operator if he is a licensed pilot. In all such cases the work done should be recorded and signed for in the log book by the person carrying out the work. There may be cases when the CAA will direct that a CRS is to be issued under exceptional circumstances. In such cases the C of A will be endorsed to that effect.

5.1.6 Whenever a Certificate of Fitness for Flight is issued in accordance with BCAR Section A, Chapter A3–8 and Section B, Chapter B3–8, the aircraft log book should be endorsed with the reason for its issue including the condition being invoked (i.e. the specific 'A' Condition), and a copy included in the log book.

5.1.7 Duplicate inspections certified in accordance with BCAR Section A, Chapter A6–2 must be recorded in the appropriate log book except that, if made elsewhere such as in the Technical Log, they may be cross-referred to in the log book.

5.1.8 For aircraft exceeding 2730 kg MTWA, it is required that a separate Modification Record Book be maintained. A suitable book is available from the CAA (CAP 395).

5.2 Information Recording Practice

5.2.1 General

a) Maintenance and Inspection (including routine inspections)

- i) When maintaining the record of compliance with mandatory requirements, all sources of such requirements must be complied with. The primary source is the regulatory authority of the country of design certification of the aircraft, engine, propeller or items of equipment, in addition to which there may be CAA Additional Directives imposed.
- ii) When a mandatory requirement is of a repetitive nature it is important to highlight this fact so that it will not be confused with once-only requirements.
- iii) Inspections of an optional nature, if adopted, should be recorded. It is recommended that such inspections, when strongly recommended by the manufacturers, should either be adopted or the justification for non-adoption be recorded.
- iv) When a mandatory requirement can be complied with via a choice or combination of options, the method of compliance must be recorded, and where compliance is by a series of progressive actions the extent of compliance must be kept accurately on record.
- v) When raising log books for imported aircraft, engines or propellers, a copy of the C of A for Export should be attached. After C of A renewal, the cut-off point used in the review of the technical record should be highlighted. Usually, in log books this is achieved by ruling off the affected page, recording totals for each column and continuing on a fresh page. In order to facilitate any maintenance review required by the ANO, it is essential that the record is kept in a form and location readily accessible to the person carrying responsibility for the review.
- vi) When considering adjustable-pitch propellers in relation to the requirements for log books it would be sensible to deem such a propeller to be of variable pitch, resulting in a need for a log book. The alternative approach would be to treat it as any other major part with no log book, i.e. all information to be included in the Aircraft Log Book.

b) Overhauls

Details of any overhauls should be included in the relevant log book except that where the details are contained in another document such as an Approved Certificate or equivalent foreign certification acceptable to the CAA, it is only necessary to make a cross-reference in the log book to identify the document. Such documents should be retained as part of the record.

c) Replacements

- i) Details of any replacements should be included in the relevant log book. Where any component is the subject of a life control system, it must be possible to readily establish the status of such components relative to the life control system.
- ii) Various methods are available to prove component status but two are perhaps more common, i.e. component listings and component cards. These cards must include the date and aircraft hours or other parameter(s) at which the item was fitted and the remaining life available on the item. Note that lives can be expressed in a number of parameters apart from hours flown, and the record must be made in terms of whatever parameter is specified by the

manufacturer. Particular care must be exercised where a component is the subject of a mandatory requirement to ensure that the component fitted is always in compliance with the requirement.

- iii) Where component life control is by on-condition monitoring then the performance control parameter(s) should be recorded (where possible in a way that shows any deterioration progressively) and the record kept must be compatible with the statistical system in use. In all cases the record of component changes, or the history of rectification of a system defect should show the precise identity of items removed and fitted and all known detail of life available and expended, in addition to the reason for the work.
- iv) When a major component such as an engine, wing flap, etc. is changed, a record of all parts or accessories transferred from the removed item to the fitted item should be made, showing when necessary, remaining life available. Any serviceable items being re-used without re-living should follow a similar procedure. The information recorded should include the origin and prior location of the item. It is thus clearly vital that parts recovered from out-of-use aircraft or major assemblies for possible future re-use must at the time of recovery only be considered acceptable if their history of use is genuinely known and on record and their condition established by a person or organisation approved for the purpose.

d) Repairs

- i) A summary of any repair must be recorded including the reason for the work, with reference to supporting documentation, and must be accompanied by a CRS made by a person appropriately authorised in relation to the scope of the repair.
- ii) The log book record must include proof of origin of all materials and parts used unless the organisation concerned is CAA Approved and operates a system under the Approval for the control of procurement and use of materials or parts.
- iii) Any record of repair involving welding should include the welder's Approval number, in addition to a CRS which must be issued by the person taking responsibility for the work.

e) Modifications

- i) All modifications must be recorded in the appropriate log book and when required, in the Modification Record Book, quoting the title and the authorisation. The latter can take the form of an Airworthiness Approval Note (AAN) number issued by the CAA, a CAA Form AD 261 reference number issued by the CAA, an Alert Service Bulletin, Service Bulletin or other document issued by an organisation taking design responsibility for the modification under a CAA Approval or by a foreign authority acceptable to the CAA. All supporting documents such as drawings, Supplemental Type Certificate, etc. should be listed or, if kept separately, cross-referred to.
- ii) When the modification is satisfying a mandatory requirement the record should highlight this fact and should be cross-referred to in the separately maintained record of compliance with mandatory requirements, showing clearly the extent of compliance.

NOTE: Further information on modification procedure is contained in BCAR Section A, Chapter A2-5.

5.2.2 Aircraft Log Books

- a) The identity of the engine and where appropriate, any propellers should be included. In the case of fixed-pitch propellers for which no log book is required, the Aircraft Log Book is likely to be the only location of such information.
- b) It is usual to make provision for a range of rigging information with datums and tolerances, the completion of which would normally be the responsibility of the manufacturer or the person who initially issues the log book.

5.2.3 Engine Log Books

- a) The installed location of the engine and the identity of the aircraft to which it is fitted should be shown. The Engine Inspection and Test Certificate should be fixed into the log book. This certificate should carry the data set out in BCAR Section A, Chapter A4–2 and include the date and reference of the CAA Approval Letter, or the latest issue of the Engine Type Certificate Data Sheet, the category of release (i.e. Experimental Flight, Transport Category – Passenger etc.), reference to inspection and test records and a list of parts subject to individual life control (overhaul, ultimate etc.).
- b) For engines of modular manufacture, a log must be maintained for each module and the log must be treated as part of an engine's technical record for as long as it is installed on the particular engine. The module record should include full identity details, history of use, a record of flight times and cycles and maintenance and rectification work carried out. All life-limited components must be identified with their limiting parameters shown, e.g. the maximum permitted number of thermal cycles and proportion of life remaining. The log for that module which carries whole-engine identity and the Data Plate should in addition carry a record of module changes with identities as well as all the information normally required in an Engine Log Book. Each module record should have attached the manufacturers or overhaulers document approximating to the Engine Inspection and Test Certificate issued for a whole engine.

5.2.4 Variable-Pitch Propellers

The basic pitch setting should be recorded whenever it has been set, altered or verified. The identity of individual blades should be included initially and then maintained, since the log book associates with the hub.

6 The Upkeep of Log Books

- 6.1 Permanent legibility is the keynote. Handwritten entries must be made in ink or indelible pencil. Any document kept in or with the log book should be either securely attached or kept in an attached pocket but should not prevent reference to the page to which it is attached.
- 6.2 Initiation of a continuation log book is the responsibility of the user and he should transfer sufficient data for continuity and should number the log books consecutively.
- 6.3 Each completed column of figures should be totalled and carried forward.
- 6.4 Any error should be corrected but remain legible. The corrections should be signed. In a machine system errors discovered after the data has been inserted into the memory should be corrected by a new entry not an erasure and the correct entry annotated as a correction with an authorisation code.
- 6.5 All record keepers must remain aware of those actions which constitute offences under the ANO.

7 Transfer of Responsibilities for Upkeep of a Log Book System

- 7.1 After a log book or records system changes hands, it remains the responsibility of the previous operator or keeper to retain the existing record intact except that if the new operator or keeper demands custody of the existing records, it is a requirement that the previous keeper complies with the demand, at which time full responsibility for the record is also transferred. A new operator should ensure that the records reflect the new situation and any change of ownership if applicable.
- 7.2 Where an alternative form of Technical Records system was being utilised, continuation by a new owner, operator, or maintenance organisation, or the introduction of any other system may not be made without the prior approval of the CAA.
- 7.3 All log books and associated records must be retained until two years after the aircraft engine or propeller is destroyed or permanently withdrawn from use, whoever may be the custodian of the records.

Chapter 8 Weighing

Leaflet 8-10 Weight and Balance of Aircraft

1 Introduction

1.1 **General.** The purpose of this Leaflet is to provide guidance on the weighing of aircraft to determine the Basic Weight and corresponding centre-of-gravity (c.g.). The need for accuracy when weighing aircraft is extremely important. Incorrect data could cause subsequent overloading of the aircraft resulting in an increase of structural loads and a reduction in performance. Subject headings are as follows:

Paragraph	Subject	Page
1	Introduction	1
2	Requirements	2
3	The Principles of Aircraft Weight and Balance	4
4	Weighing Equipment	8
5	Determination of Basic Weight and Centre-of-Gravity	10
6	Change in Basic Weight	21
7	Loading of Aircraft	24
Appendix	Typical Weight and Centre-of-Gravity Schedule	27

1.2 **Definitions.** The following is a list of definitions of the terms used in this Leaflet:

- a) **Basic Equipment** – is the unconsumable fluids (e.g. coolant and hydraulic fluid) and equipment which is common to all roles for which the operator intends to use the aircraft.
- b) **Basic Weight** – is the weight of the aircraft and all its Basic Equipment, plus that of the declared quantity of unusable fuel and unusable oil. In the case of turbine-engined aircraft and aircraft, the Maximum Total Weight Authorised (MTWA) of which does not exceed 5700 kg (12 500 lb), it may also include the weight of usable oil.
- c) **Variable Load** – is the weight of the crew and of items such as crew baggage, removable units, and other equipment, the carriage of which depends upon the role for which the operator intends to use the aircraft for a particular flight.
- d) **Disposable Load** – is the weight of all persons (e.g. passengers) and items of load, including fuel and other consumable fluids carried in the aircraft, other than the Basic Equipment and Variable Load.
- e) **Maximum Total Weight Authorised (MTWA)** – is the Maximum Total Weight Authorised for the aircraft and its contents, at which the aircraft may take off anywhere in the world, in the most favourable circumstances in accordance with the Certificate of Airworthiness or Flight Manual.
- f) **Reaction** – is the load at each separate weighing point.

2 Requirements

- 2.1 The requirements relating to the weighing of aircraft and the establishment of a Weight and Balance Schedule are prescribed in British Civil Airworthiness Requirements (BCAR) Section A, Chapters A5–4, A6–4 and A7–10. An interpretation of those parts of the Chapters which are pertinent to this Leaflet are given below.
- 2.2 Aircraft must be weighed to determine the Basic Weight and the corresponding c.g. position when all the manufacturing processes have been completed. Aircraft exceeding 5700 kg (12 500 lb) MTWA must be re-weighed within 2 years after the date of manufacture and, after this, a check weighing must be carried out at intervals not exceeding 5 years and at such times as the CAA may require. Aircraft not exceeding 5700 kg (12 500 lb) MTWA must be re-weighed as required by the CAA.
- 2.3 In making decisions on weighing, the CAA considers the history of the aircraft, its flying performance, and the probable effect on the weight after a major overhaul, or embodiment of a modification, repair or replacement.
- 2.4 Certain types of aircraft may be weighed on a sampling basis (i.e. a representative aircraft, as weighed, would be acceptable for others of the same standard) by agreement with the CAA.
- 2.5 An alternative arrangement to the periodical check weighing of individual aircraft is for the operator to establish a fleet mean weight (i.e. Basic Weight) and fleet mean centre-of-gravity position. The initial fleet mean weight is based on the mean of the weights of all the aircraft of the same type in the fleet which is revised annually by sample weighing (see BCAR, Section A, Chapter A6–4).
- 2.6 When an aircraft is weighed, the equipment and other items of load such as fluid in the tanks must be recorded. This recorded load should not differ significantly from the Basic Equipment List associated with the Weight and Centre-of-Gravity Schedule (see paragraph 2.9). In circumstances where there is a significant difference between the Basic Weight of the aircraft and the operating weight (i.e. Basic Weight plus the Variable Load) not accountable to structural changes brought about by modifications/repairs, the CAA may require that the actual weights of the Variable Load items be ascertained.
- 2.7 All records of the weighing, including the calculations involved, must be available to the CAA. The records are retained by the aircraft manufacturer, overhauler or operator, and when the aircraft is weighed again, the previous weighing records must not be destroyed but retained with the aircraft records. Operators must maintain records of all known weight and c.g. changes which occur after the aircraft has been weighed.
- 2.8 **Weight and Balance Report**
- 2.8.1 Before the CAA can issue a Certificate of Airworthiness for a prototype, variant (prototype modified) or series aircraft exceeding 5700 kg (12 500 lb) MTWA, a Weight and Balance Report must be prepared by a CAA Approved Organisation.
- 2.8.2 The Weight and Balance Report is intended to record the essential loading data to enable a particular aircraft to be correctly loaded, and to include sufficient information for an operator to produce written loading instructions in accordance with the provisions of the Air Navigation Order (ANO). The Weight and Balance Report applies to the aircraft in the condition in which it is to be delivered from the manufacturer to the operator.
- 2.8.3 The Weight and Balance Report must include the following items:

- a) Reference number and date.
- b) Designation, manufacturer's number, nationality and registration marks of the aircraft.
- c) A copy of the Weighing Record.
- d) A copy of the Weight and Centre-of-Gravity Schedule (see paragraph 2.9) including the Basic Equipment List if this is separate from Part A of the Schedule.
- e) A diagram and a description of the datum points which are used for weighing and loading, and an explanation of the relationship of these points to the fuselage frame numbering systems and, where applicable, to the Standard Mean Chord (SMC).

NOTE: SMC is also referred to as the Mean Aerodynamic Chord (MAC).

- f) Information on the lever arms appropriate to items of Disposable Load. This will include the lever arms of fuel, oil and other consumable fluids or substances in the various tanks (including agricultural material in hoppers), which, if necessary, should be shown by means of diagrams or graphs, lever arms of all passengers in seats appropriate to the various seating layout, mean lever arms of the various baggage holds or compartments.
- g) Details of any significant effect on the aircraft c.g., of any change in configuration, such as retraction of the landing gear.

2.9 **Weight and Centre-of-Gravity Schedule**

- 2.9.1 A Weight and Centre-of-Gravity Schedule details the Basic Weight and c.g. position of the aircraft, the weight and lever arms of the various items of load including, fuel oil and other fluids.

The Schedule is normally divided into Part A – Basic Weight, Part B – Variable Load and Part C – Loading Information (Disposable Load).

- a) A Weight and Centre-of-Gravity Schedule shall be provided for each aircraft, the MTWA of which exceeds 2730 kg (6000 lb).
- b) For aircraft not exceeding 2730 kg (6000 lb) MTWA, either a Weight and Centre-of-Gravity Schedule shall be provided or alternatively, a Load and Distribution Schedule which complies with BCAR, Section A, Chapter A7–10 and Section B, Chapter B7–10.
- c) For new aircraft exceeding 2730 kg (6000 lb) MTWA, but not exceeding 5700 kg (12 500 lb) MTWA, the information contained in Parts B and C of the Schedule may be given as part of the Weight and Balance Report.

- 2.9.2 A Weight and Centre-of-Gravity Schedule must provide the following. Each Schedule must be identified by the aircraft designation, the nationality and registration marks, or if these are not known, by the manufacturer's serial number. The date of issue must be on the Schedule and it must be signed by an authorised representative of a CAA Approved Organisation or a person suitably qualified and acceptable to the CAA, and if applicable, a statement shall be included indicating that the Schedule supersedes all earlier issues. It is also necessary to refer to the date or reference number (or both) of the Weight and Balance Report, or other acceptable information upon which the Schedule is based.

- 2.9.3 Operators must also issue a revised Weight and Centre-of-Gravity Schedule when it is known that the weight and c.g. has changed in excess of the maximum figure agreed by the CAA as applicable to a particular aircraft type. If the aircraft has not been re-weighed, the revised Weight and Centre-of-Gravity Schedule must state that it has

been calculated on the basis of the last Weight and Balance Report and the known weight and c.g. changes. A record of the calculations involved should be retained for future reference.

- 2.9.4 A copy of the Schedule is to be retained by the operator with a further copy sent to the CAA Safety Regulation Group which shall include any related list of Basic Equipment. Furthermore, for aircraft not exceeding 5700 kg (12 500 lb) MTWA, a copy of the Weight and Centre-of-Gravity Schedule must be included in the Flight Manual. If a Flight Manual is not a requirement, the Schedule must be displayed or retained in a stowage which is identified in the aircraft. A similar arrangement is often used for larger types of aircraft.
- 2.9.5 A typical Weight and Centre-of-Gravity Schedule for an aircraft not exceeding 2730 kg (6000 lb) MTWA is shown in the Appendix to this Leaflet.

3 The Principles of Aircraft Weight and Balance

3.1 Principles of Balance

- 3.1.1 The theoretical principle of the weight and balance of aircraft is basically very simple and can be compared with that of the familiar scale (as depicted in Figure 1) which, when in balance, will rest horizontally on the fulcrum in perfect equilibrium provided that the two pans suspended from the beam are of equal weight and distance from the fulcrum.
- 3.1.2 In aeronautical terms the fulcrum can be equated to the aircraft c.g., and the weights, with the loads imposed thereof on the structure.
- 3.1.3 Because of the design tolerances built into aircraft, the Weight and Balance is not as critical as that of the scales in Figure 1. It is however important that they remain within those tolerances for reasons of safety, performance and economy.
- 3.1.4 From Figure 1 it can be understood that the influence of weight, in relation to balance, is directly dependent upon the distance of the weight from the fulcrum.

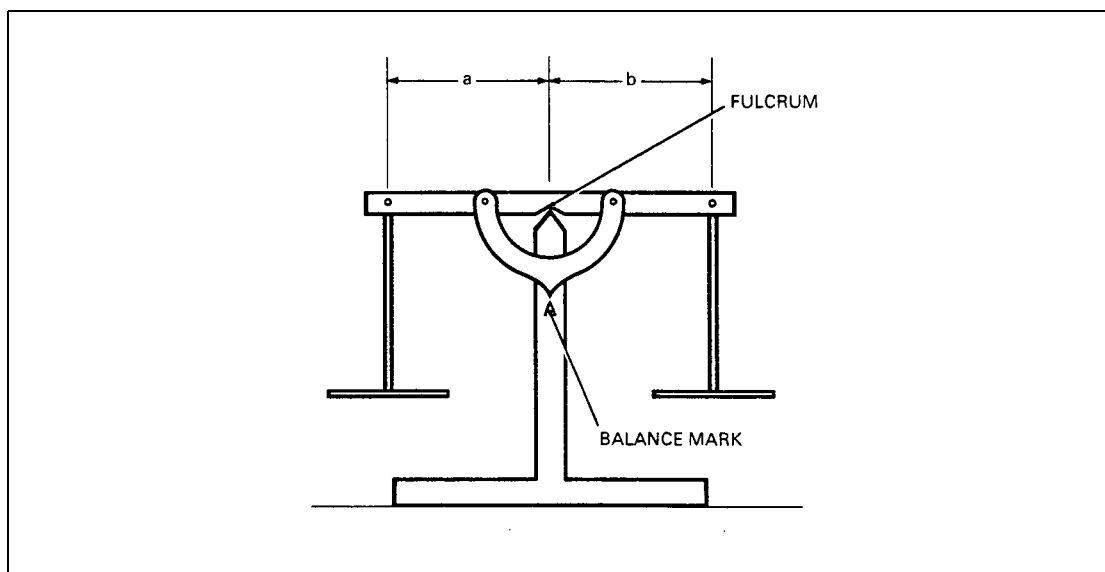

Figure 1 Simple Scale

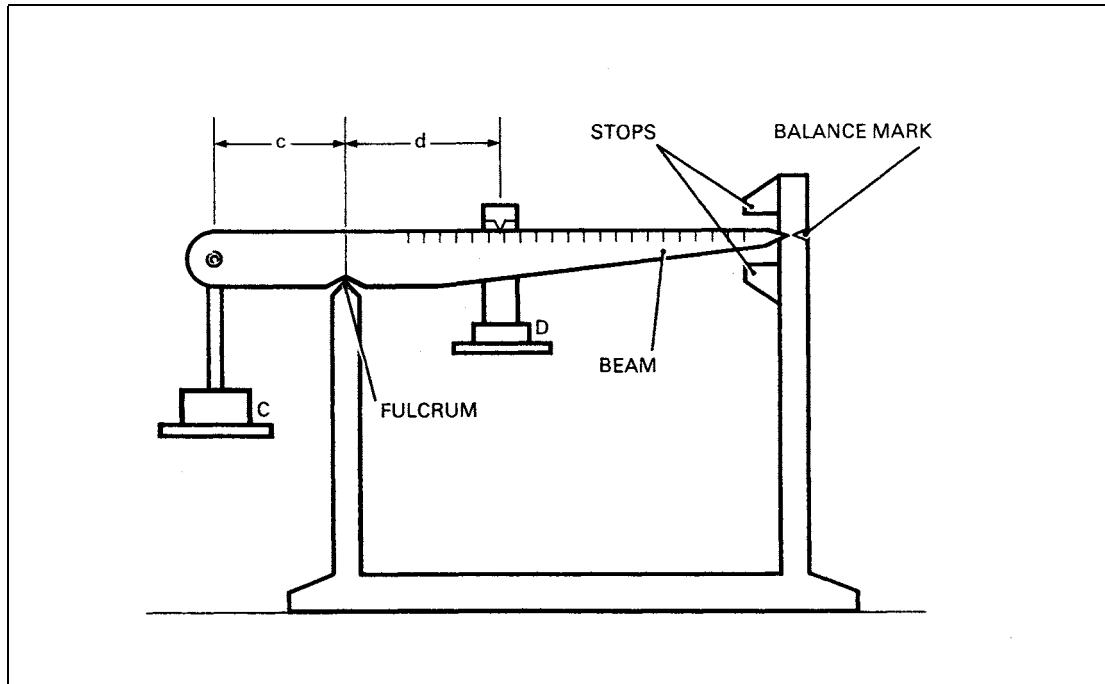

Figure 2 Steelyard

- 3.1.5 Unlike the scales in Figure 1, aircraft (apart from some helicopters), cannot practically be suspended in such a way as to determine the relative weight, balance and c.g. However, it can be achieved mathematically.
- 3.1.6 The steelyard shown in Figure 2 has a known weight 'D' and a known weight 'C' set at a specific distance 'c'. Under normal circumstances to determine the distance required to balance 'C', the known weight 'D' is moved along the beam until the weight of 'D' and its accompanying lever arm are equal to the weight of 'C' therefore aligning the beam with the balance mark. Once achieved the distance 'd' can then be read from the graduated scale.
- 3.1.7 Mathematically the distance can be found as follows:

$$d = \frac{Cc}{D}$$

Where C = 50 lb

c = 10 inches

D = 20 lb

$$\frac{Cc}{D} = \frac{50 \times 10}{20}$$

d = 25 in

3.2 Moments

3.2.1 The distance from the fulcrum is called the 'arm' and this distance, multiplied by the weight, is the turning effect or 'moment' about the fulcrum. The c.g. of the balanced system is the position at which the weight resting on the fulcrum may be taken to act, and will lie in a plane drawn vertically through the fulcrum. The conventional signs which are applied to arms and moments in relation to their direction from the c.g. datum are as follows:

- a) **Horizontal** (–) forward and (+) aft of the datum.
- b) **Vertical** (–) below and (+) above the datum.
- c) **Transverse** (–) right and (+) left of the datum.

3.2.2 In a similar way to the balancing of weights, the horizontal c.g. of a system of weights can be found by calculating the moment of each weight from a selected position (e.g. reference datum) and dividing the total moment by the total weight.

NOTE: In aeronautical terms all arms forward of the reference datum are designated negative (–) and all arms aft of the datum are designated positive (+).

3.2.3 Illustrated in Figure 3 is a constant cross-section beam 80 in long and weighing 8 lb, upon which have been placed 5 loads weighing 2 lb, 6 lb, 1 lb, 4 lb and 3 lb respectively, which are 5 in, 20 in, 30 in, 60 in, 70 in, from the left-hand end of the beam, which in this example is the c.g. reference datum. It should be noted however, that although any plane normal (i.e. perpendicular) to the beam's horizontal axis could have been selected as the reference datum, the position chosen is one of convenience, and therefore all moment arms in this example are positive (+). As the beam is of a constant cross-section, the c.g. of the loaded beam in Figure 3 can be found as follows by:

- a) calculating the moment of each load, i.e. multiplying the weight by arm (distance from the reference datum),
- b) calculating the total weight by adding together the weight of each load,
- c) adding together the moment of each load, and
- d) dividing the total moment by the total weight.

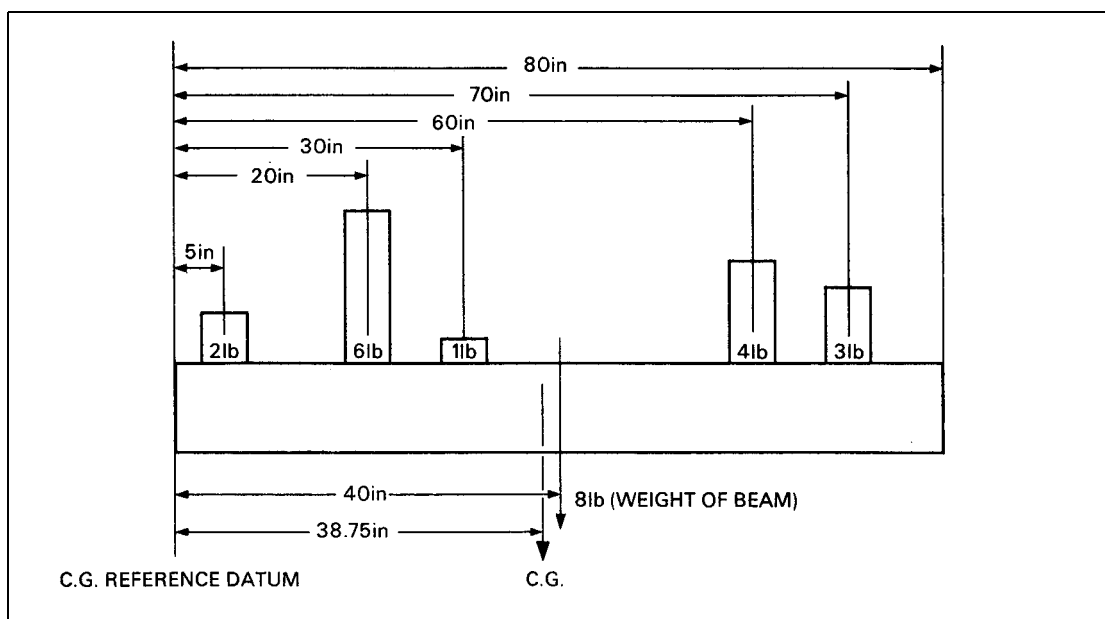

Figure 3 Centre-of-Gravity of Beam

Item	Weight (lb)	Arm (in)	Moment (lb in)
Beam	8	40	320
1st load	2	5	10
2nd load	6	20	120
3rd load	1	30	30
4th load	4	60	240
5th load	3	70	210
TOTALS	<u>24</u>		<u>930</u>

$$\therefore \frac{930 \text{ lb in}}{24 \text{ lb}} = 38.75 \text{ in}$$

\therefore the c.g. of the loaded beam is 38.75 in from the reference datum.

- NOTES:**
- 1) The arm of the beam is taken as half its length.
 - 2) The units of weight, arm and moment used in this and subsequent paragraphs are the pound (lb), inch (in) and pound inch (lb in) respectively. Other units, such as the kilo-gramme (kg) and metre (m) may be used where this is more convenient for the operator but, whichever units are used, it is essential that the same units are used throughout the calculations.

3.3 Aircraft Weight and Centre-of-Gravity

- 3.3.1 The weight and c.g. of an aircraft is calculated in the same way as for the loaded beam in Figure 3. The Basic Weight and c.g. of the aircraft corresponds to the weight and c.g. of the beam, and, the Variable and Disposable Loads correspond to the beam loads. Before each flight the total weight and moment of these items must be determined, and the c.g. of the aircraft calculated to ensure the aircraft remains within the approved limits. If for example, the c.g. was too far forward, it would result in a nose-heavy condition which could be potentially dangerous (particularly during take-off and landing), cause a general reduction in the performance of the aeroplane, and effect an increase in fuel consumption as a result of the drag caused by excessive balancing of the elevator trim. Where rotorcraft are concerned, a c.g. too far forward could result in excessive strain on the main rotor shaft and a general lack of control. The c.g. too far aft results in a tail-heavy condition which, with the tendency of the aeroplane to stall, makes landing more difficult, may result in a reduction in performance, and cause an increase in fuel consumption. In the case of rotorcraft it will reduce the forward speed and also the range of effective control.
- 3.3.2 The operational limitations for the fore and aft positions of the c.g. are defined in the aircraft Flight Manual or other document associated with the Certificate of Airworthiness, such as the Owner's Manual. Where no such document exists, the limitations are specified in the Certificate of Airworthiness.

- 3.3.3 Fortunately it is not necessary for an aircraft to be perfectly balanced to achieve stable flight, i.e. to an exact c.g. position. The permissible variation is called the Centre-of-Gravity Range. This is specified by the manufacturer for each aircraft type and is determined by the need to comply with various airworthiness design requirements.

4 Weighing Equipment

4.1 General

The main types of weighing equipment for use in the weighing of aircraft are weighbridge scales, hydrostatic weighing units and electrical and electronic weighing equipment based on the strain gauge principle. Since considerable errors can arise if small loads are checked with equipment designed for heavy loads, whereby scales may be calibrated in increments too coarse for accurate calculation, the capacity of the weighing equipment should be compatible with the load.

NOTE: All weighing apparatus should be checked, adjusted and certified by a competent authority at periods not exceeding 1 year and, in addition, the zero indication should be checked for accuracy before any weighing is commenced.

4.2 Weighbridge Scales

This equipment consists of a separate weighing platform for each wheel or bogey on the aircraft, the weight at each reaction point being recorded directly on the balance arm. On some equipment a dial indicator is also provided. Large aircraft are normally weighed in a hangar, using either portable weighbridge scales or weighbridges set permanently into the floor at appropriate positions with their platforms level with the floor. The aircraft may then be rolled directly onto the platforms without the need for special equipment.

NOTES:

- 1) Care should be taken when moving portable weighbridge scales to prevent them becoming out of balance.
- 2) It is advisable to set the approximate load on each balance arm before releasing it. Failure to do this could cause damage to the knife edge.

4.3 Hydrostatic Weighing Units

- 4.3.1 The operation of these units is based on the hydraulic principle that the fluid pressure in a cylinder in which a piston is working, depends on the area of the piston and the load applied to it. The units are interposed between the lifting jacks and the aircraft jacking points, the weight at each position being recorded on a pressure indicator. The indicator may record directly in units of weight or may be a multi-rotational type where the readings are converted to weight by means of a conversion table peculiar to each particular unit.

- 4.3.2 It is important that the lifting jacks are exactly vertical and the units correctly positioned, otherwise side loads may be imposed on the weighing units and may affect the accuracy of the readings.

4.4 Electrical Weighing Equipment

Equipment of this type incorporates three or more weighing cells, each of which contains a metallic element of known electrical resistance. Aircraft load is measured with the variation in resistance with elastic strain by means of a galvanometer, the scale of which is calibrated in units of weight. As with the hydrostatic weighing units, the weighing cells are interposed between the lifting jacks and the aircraft jacking points and similarly care is necessary to ensure that no side loads are imposed upon them. (See paragraph 4.3.2.)

4.5 Electronic Weighing Equipment

4.5.1 This type of weighing equipment combines elastic strain load cells as described in paragraph 4.4 into weighbridge-type platforms which are placed either as a single unit or combination of units beneath the wheels of the aircraft undercarriage.

4.5.2 Each platform, is electrically connected to an instrumentation unit, which digitally displays the selected platform load. The number of platforms required to weigh an aircraft by this method is determined by the size of the aircraft. For example, a very large transport aircraft may require as many as 18 or more platforms to accommodate the wheel multiples of the undercarriage. The number of units that can be used is, however, limited by the terminal facility of the instrumentation unit.

4.5.3 As there is generally a requirement for aircraft weighing equipment to be portable, the platforms are normally manufactured of high strength lightweight materials, with the load cells interposed between the platform table, and the base unit. Where a platform is unevenly loaded (because of structural movement or undercarriage positioning), a greater load imposed on one side of the platform will be automatically compensated for by the lesser load on the other side.

NOTE: The displayed load (or reaction) on the instrumentation unit for each platform, is a dedicated computation of all load cell inputs from that particular platform.

4.5.4 The positioning of aircraft onto electronic weighbridge platforms may be accomplished by one of the following methods:

- a) by towing the aircraft directly onto platforms permanently set into the hangar floor (sometimes in specific appropriate positions),
- b) by supporting the aircraft on jacks and, where facilities allow, lowering the hangar floor, positioning the platforms below the extended undercarriage and then raising the hangar floor until all the weight of the aircraft is supported by the platforms, or
- c) by towing the aircraft up purpose-made ramps (approximately 6%) onto the platforms.

4.5.5 The function of the instrumentation unit is to:

- a) Compute and display the loads imposed upon each platform.
- b) Provide a facility for the fine calibration of the platforms to a zero datum.
- c) Record and print out the indicated data.

NOTE: Some instrumentation units (subject to the necessary inputs) also have the capability to compute both the total weight and the relative c.g. of the aircraft.

5 Determination of Basic Weight and Centre-of-Gravity

5.1 General

Modern aircraft may be weighed using any of the equipment described in paragraph 4. Arms from the c.g. datum are predetermined distances and therefore physical measurement is seldom required. However, when weighing certain types of aircraft on their wheels, it may be necessary to take measurements due to the possibility of landing gear compression or deflection altering the length of the lever arm. Furthermore, before weighing is commenced, reference should be made to the manufacturer's recommended weighing procedures.

NOTE: It is important for large fixed-wing transport aircraft to be level in both the longitudinal and lateral planes when being weighed. However, for light fixed-wing aeroplanes the emphasis is normally on the longitudinal plane.

5.2 Preparation for Weighing

- 5.2.1 The aircraft should be in the condition described in the Weight and Centre-of-Gravity Schedule, fluids such as engine oil, or fuel being partially or completely drained in accordance with the manufacturer's requirements, and equipment positioned at its normal operational location.
- 5.2.2 It is important to carry out the weighing of aircraft inside a closed hangar, and where possible, it is recommended that the aircraft is positioned in the hangar several hours before weighing so that it can assume an even temperature and be free from moisture. If weighing in the open is unavoidable, it should be carried out on a firm level site when wind force is at a minimum with the aircraft completely dry (i.e. not affected by frost or dew) and several readings should be taken at each reaction point to obtain a reliable average figure. Also particular care should be exercised if plumb bobs are to be used for taking measurements.
- 5.2.3 In order to obtain consistent results from different weighings, it is essential that an aircraft is placed in the 'rigging' position (i.e. with the longitudinal axis parallel to the floor). Jigged positions are normally built into an aircraft structure for levelling purposes and these may be used in conjunction with a spirit level or plumb bob and scale. Instructions supplied by the relevant aircraft manufacturer on levelling procedures and the positioning of equipment should be carefully followed and adhered to.
- 5.2.4 It should be noted, however, that some light aeroplanes with tail-wheel landing gear, have a negative load on the tail when in the rigging position as a result of the c.g. being forward of the main wheel centres. In such cases, and where it is not possible to use a jack at the nose of the aeroplane, a spring balance should be anchored securely to the ground and attached to the tail wheel axle to determine the extent of the negative reaction. Since this is a minus load, it should be deducted from the total weight, and must be treated as a minus quantity when calculating the c.g. position.

- NOTES:**
- 1) The weight of the spring balance, and any rope used to secure it to the aircraft, must be added to the spring balance reading.
 - 2) Two position weighings, i.e. datum horizontal and nose up or down, are sometimes used when necessary to determine the vertical c.g. position, but this is not normally carried out by operators.

5.3 Weighing on Weighbridge Scales or Platforms

- 5.3.1 This is normally carried out with the aircraft resting on its wheels, but is often necessary to jack the aircraft at either the nose or tail to level it longitudinally. In the circumstances where the normal aircraft attitude is almost level, the manufacturer may recommend that the tyres or oleo struts are partially deflated to obtain the corrected position. The weight of any equipment used for levelling must be deducted from the weight recorded at the particular scale. The example given in Figure 4 is a nosewheel aircraft on which, because of landing gear deflection, it is required to measure the distance between reaction points.
- 5.3.2 **Electronic Platform Weighing Equipment.** To achieve the degree of accuracy possible with this type of equipment, careful preparation is important and this will include:
- a) Checking and adjusting the platforms to a horizontal level in the longitudinal and lateral planes.

- b) Switching on the instrumentation unit prior to weighing to allow for temperature stabilisation of electronic circuits as specified by the relevant equipment manufacturer.
- c) Adjusting and setting each platform to zero datum point through the instrumentation unit.
- d) Correcting the aircraft's longitudinal level.
- e) Ensuring the hangar is free from destabilising draughts, e.g. hangar doors ajar, warm/cold air blowers, etc.

NOTE: After the aircraft has been weighed and removed from the platforms, a platform zero datum check at the instrumentation unit should be repeated.

- 5.3.3 With the main wheels located centrally on the weighbridge platforms and wheels checked, the wheel brakes should be released and the nose raised or lowered until the fuselage is longitudinally level. Plumb bobs should be suspended from the centrelines of the main wheel axles on the inner side of the wheels, and the two positions marked on the floor (see Figure 5). The midway point between these two marks represents the rear reaction point. A plumb bob suspended from the centrelines of the nose-jacking point will enable the distance between the front and rear reaction points to be measured (see Figures 4 and 5).

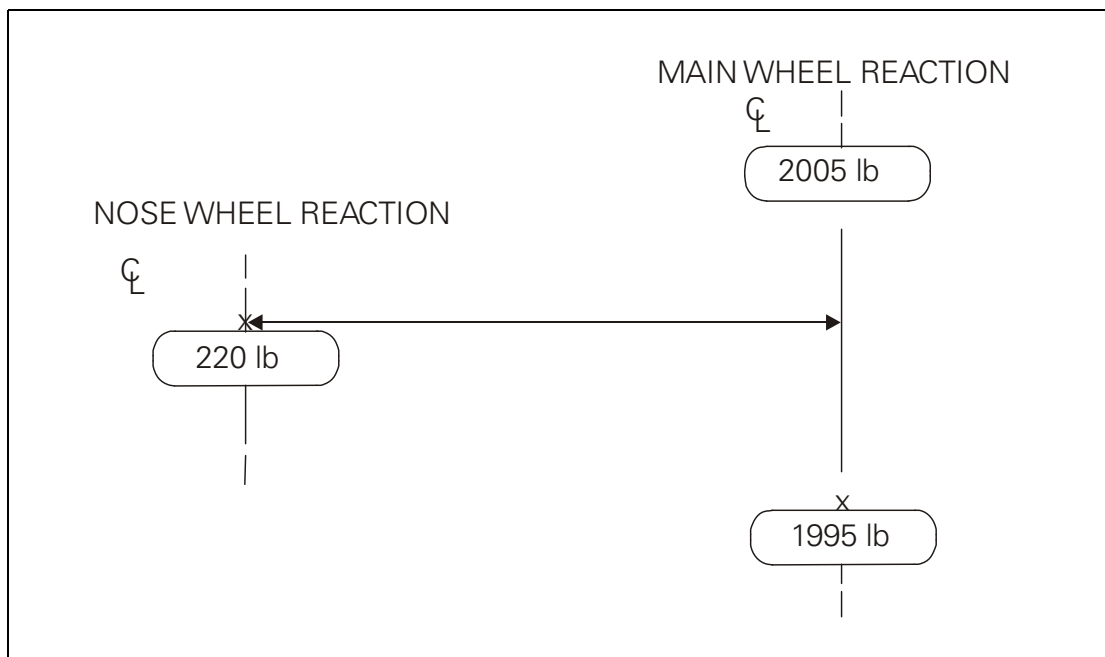

Figure 4 Light Aircraft

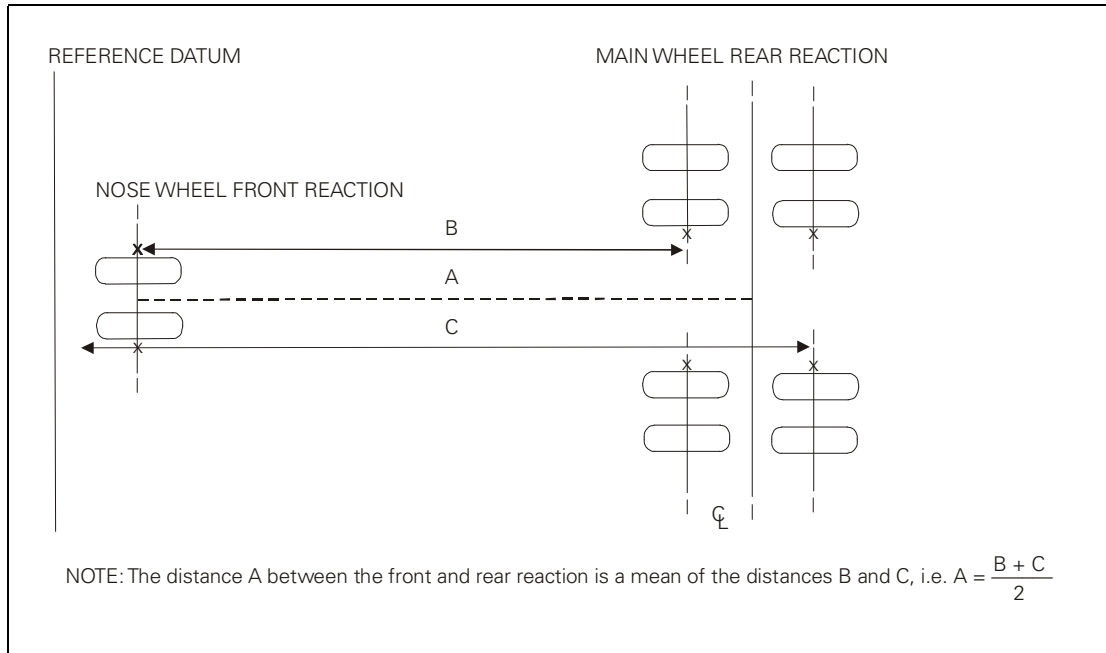

Figure 5 Heavy Aircraft

5.3.4 The c.g. can then be found by the following formula:

$$\frac{A \times W_1}{W_2}$$

- Where A = distance between front and rear reactions
- W₁ = weight at the nose or tail wheel
- W₂ = Basic Weight

For example:

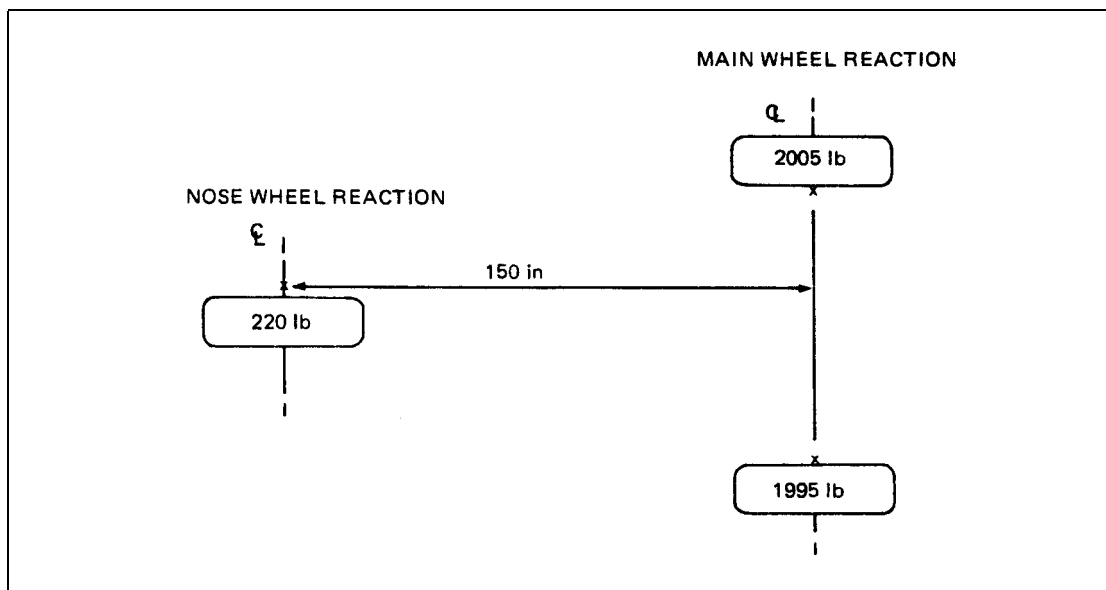

Figure 6 Centre-of-Gravity Relative to the Main Wheels

$$\begin{aligned}
 A &= 150 \text{ in} \\
 W_1 &= 220 \text{ lb} \\
 W_2 &= 4220 \text{ lb (i.e. } 220 + 1995 + 2005)
 \end{aligned}$$

$$\begin{aligned}
 \text{Thus: } \frac{A \times W_1}{W_2} &= \frac{150 \times 220}{4220 \text{ lb}} \\
 &= \frac{33\,000 \text{ lb in}}{4200 \text{ lb}} \\
 &= 7.82 \text{ in}
 \end{aligned}$$

∴ the c.g. is 7.82 in forward of main wheel centreline.

5.4 Reference Datums

5.4.1 Whenever a c.g. distance is reference to the main wheel centreline, it should always be corrected to relate to the reference datum, and its associated moment calculated. The purposes of this correction are twofold. Firstly, in terms of measurement, it relates the c.g. to the reference datum. Secondly, in terms of total moment (and Basic Weight), it establishes the necessary mathematical datum point for subsequent calculations with regard to the operation and maintenance of the aircraft.

5.4.2 Centre-of-Gravity correction to the reference datum is achieved by:

- a) suspending a plumb bob from the reference datum,
- b) measuring the distance, parallel to the aircraft's longitudinal centreline, from the reference datum to the main wheel reaction point centreline and,
- c) either adding or subtracting this measurement to or from the distance of the c.g. from the main wheel centreline.

Example 1:

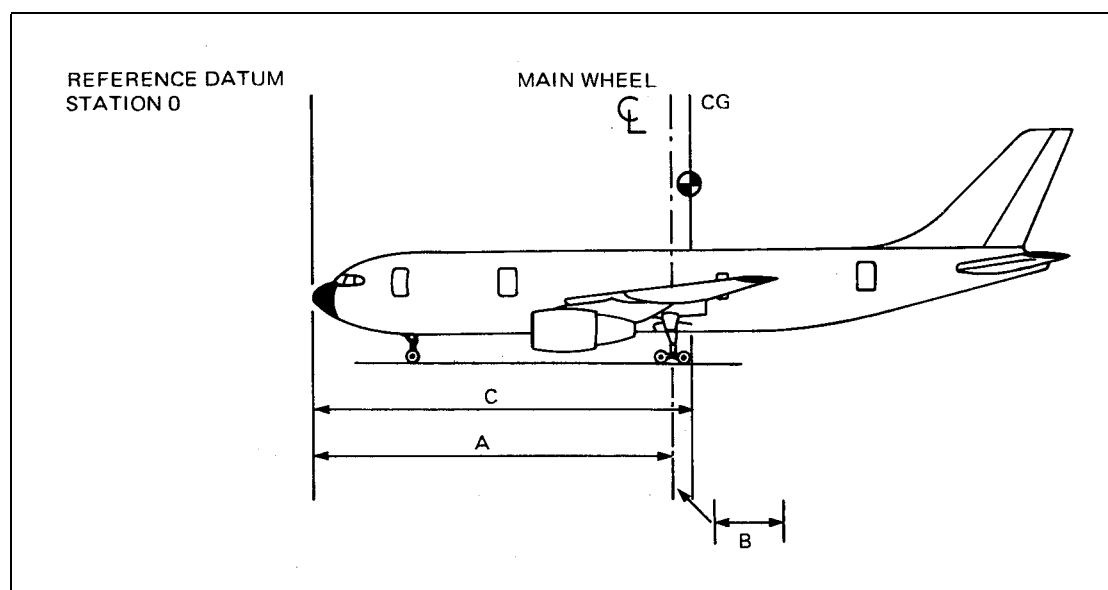

Figure 7 Centre-of-Gravity Correction to the Reference Datum

$$\begin{aligned} A &= 626 \text{ in forward of the main wheel reaction} \\ B &= 50 \text{ in aft of the main wheel reaction} \\ C &= A + B \end{aligned}$$

\therefore the c.g. is 676 in aft of the reference datum

Example 2:

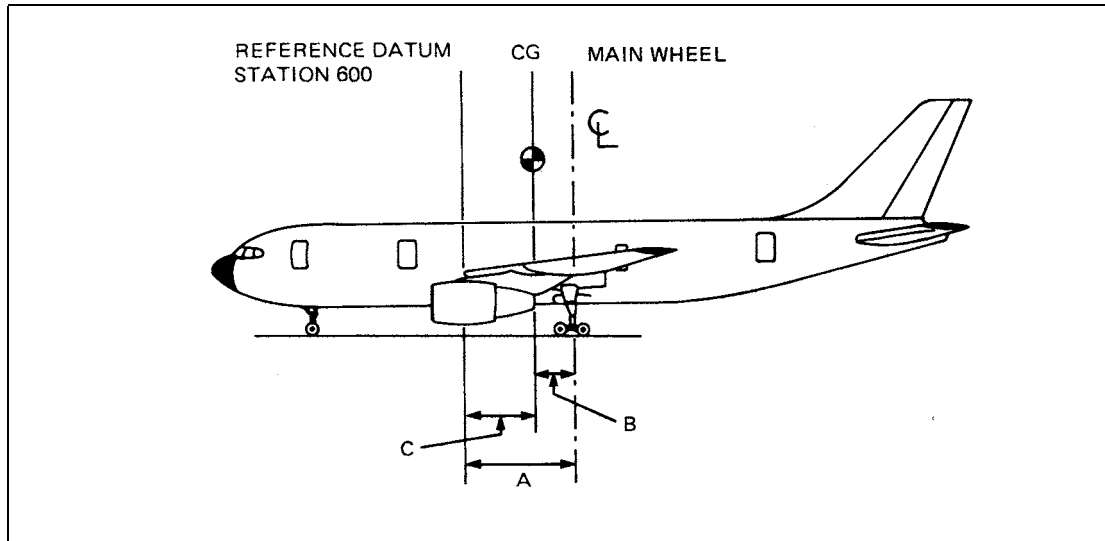

Figure 8 Centre-of-Gravity Correction to the Reference Datum

$$\begin{aligned} A &= 260 \text{ in forward of the main wheel reaction} \\ B &= 100 \text{ in forward of the main wheel reaction} \\ C &= A - B \end{aligned}$$

\therefore the c.g. is 160 in aft of the reference datum

5.4.3 Total moment can then be found by the following calculation:

Arm of the c.g. from the reference datum x Basic Weight.

For example, if a hypothetical Basic Weight of 84 000 lb is attached to the aircraft shown in Figure 7, the calculation would be as follows:

$$\begin{aligned} \text{Arm of the c.g. from reference datum} &= 676 \text{ in} \\ \text{Basic Weight} &= 84\,000 \text{ lb} \\ &= 84\,000 \times 676 \\ \text{Total Moment} &= 56\,784\,000 \text{ lb in} \end{aligned}$$

Accordingly the Weight and Centre-of-Gravity Schedule will state:

$$\begin{aligned} \text{Basic Weight} &: 84\,000 \text{ lb} \\ \text{Centre-of-Gravity} &: 676 \text{ in aft of the reference datum} \\ \text{Total Moment about the datum} &: 56\,784\,000 \text{ lb in}/100 \end{aligned}$$

NOTE: Once the c.g. and its related moment have been established, any subsequent changes to the aircraft in terms of loading, fuel uplift or modification, etc. can be re-calculated from the original Basic Weight and moment (see paragraph 6 for further details).

5.4.4 The most commonly used reference datum adopted by the majority of aircraft manufacturers is, at, or forward of, the nose of the aircraft (e.g. fuselage station zero), for the following reasons:

- a) All items of equipment whether basic or additional, will be preceded by a '+' sign (i.e. aft of the datum) thereby simplifying weight and balance computations.
- b) Offers an accessible point for the purposes of measurement and as such the moment of any item can be easily calculated by its weight and distance relative to its fuselage station.
- c) Provides a common location for future 'series' aircraft, of the type.

5.5 Tail-wheel Aircraft

5.5.1 Illustrated in Figure 9, is a typical tail-wheel aircraft positioned in a level attitude on weighbridge type platforms with a reference datum aft of the main wheel centreline.

NOTE: When it is not possible to suspend a plumb bob from the nose-jacking point, due, for example, to the jack or the trestle being in the way, a measuring point should be found by suspending the plumb bob at a predetermined distance from the jacking point, this distance being used to determine the distance between the reaction points.

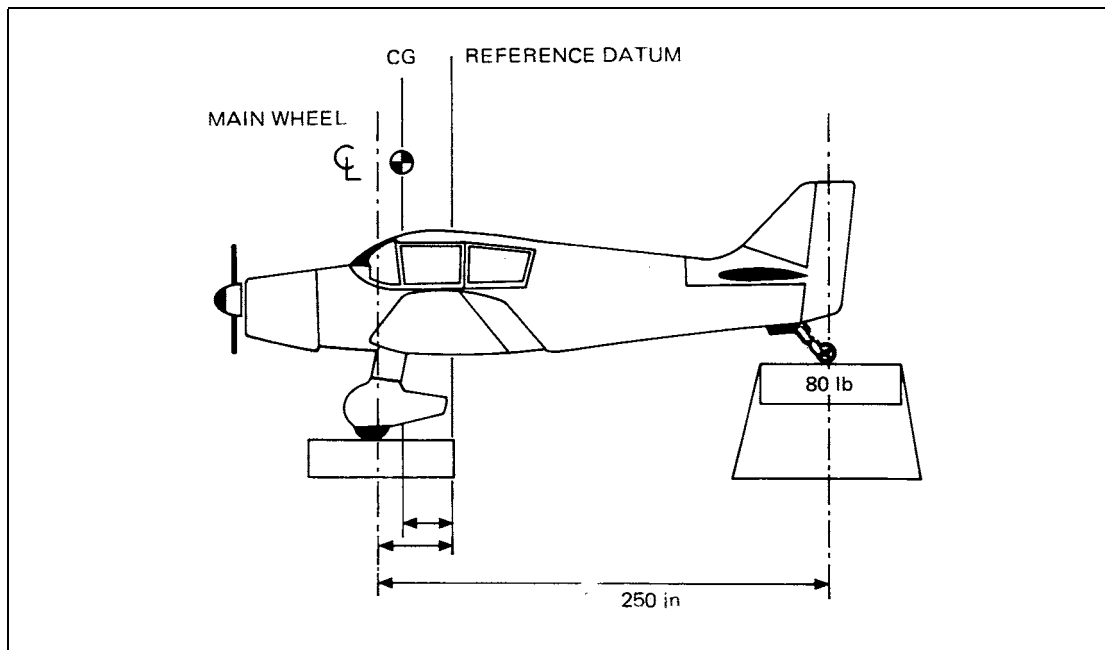

Figure 9 Tail-Wheel Aircraft

The weight at the right main wheel reaction	698 lb
The weight at the left main wheel reaction	702 lb
The weight at the tail wheel reaction	80 lb
TOTAL WEIGHT	<u>1480 lb</u>

- 5.5.2 To locate the c.g. of this type of aircraft the formula described in paragraph 5.2.4 can be adopted, i.e. tail-wheel distance A is multiplied by the tail-wheel weight, the result of which is divided by the basic weight as follows:

$$\text{c.g.} = \frac{A \times W_1}{W_2}$$

Where: A = 250 in

W_1 = 80 lb (weight at the tail wheel)

W_2 = 1480 lb

$$= \frac{250 \times 80}{1480 \text{ lb}}$$

$$= \frac{2000}{1480}$$

$$= 13.513 \text{ in}$$

∴ the c.g. is 13.513 in aft of the main wheel reaction, or alternatively 18.487 in forward of the reference datum (i.e. 32 in minus 13.513 in).

Or alternatively (see paragraph 5.6),

$$\text{c.g.} = \frac{\text{Total Moment (TM)}}{\text{Total Weight (TW)}}$$

	Weight (lb)		Arm (in)		Moment (lb in)
Right main wheel	698	x	(-) 32	=	(-) 22336
Left main wheel	702	x	(-) 32	=	(-) 22464
SUB TOTAL	1400				(-) 44800
Tail wheel	80	x	(+) 218	=	(+) 17440
				=	(-) 44800
					(+) 17440
TOTAL	1480				(-) 27360

$$\text{c.g.} = \frac{\text{TM}}{\text{TW}} = \frac{27360}{1480}$$

$$= (-) 18.487 \text{ in}$$

∴ the c.g. is 18.487 in forward of the reference datum.

5.6 An Alternative Method of Weight and Balance Calculation

- 5.6.1 There are various alternative methods to calculate the c.g. and moment of aircraft to that prescribed in the preceding paragraphs, once the basic weights and measurements have been established.
- 5.6.2 In the following example, the aircraft graphically described in Figure 10, is identical to that shown in Figure 6 except for the added reference datum. The method of calculation is the same as that used in paragraph 5.7, except that the subject aircraft has, as appropriate to this section, been weighed on platforms as opposed to aircraft jacks.

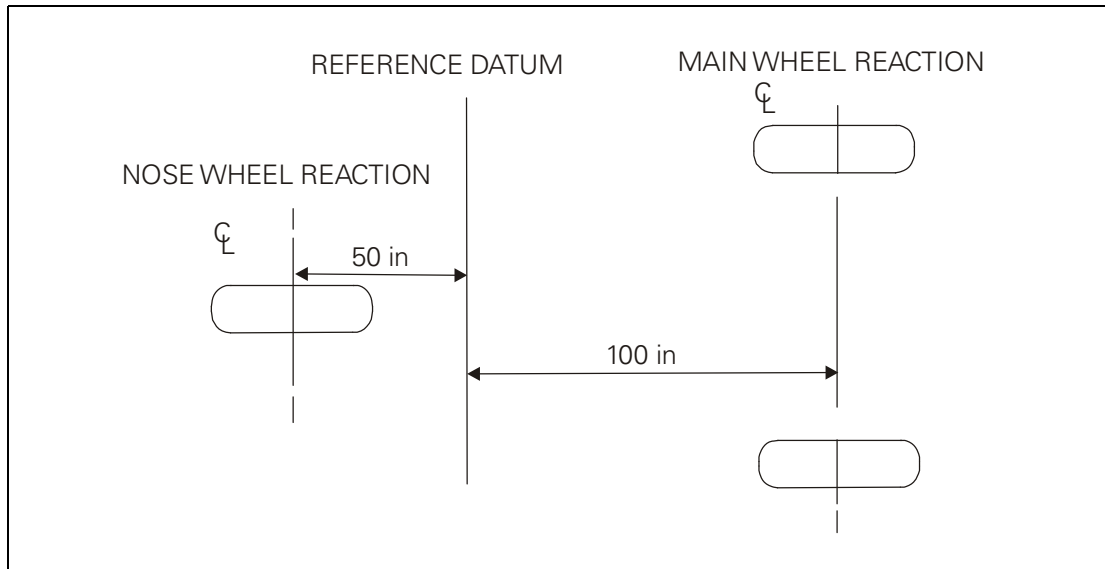

Figure 10 Centre-of-Gravity Relative to the Reference Datum

$$\text{c.g.} = \frac{\text{Total Moment (TM)}}{\text{Total Weight (TW)}}$$

	Weight (lb)		Arm (in)		Moment (lb in)
Left main wheel	1995	x	(+) 100	=	(+) 199 500
Right main wheel	2005	x	(+) 100	=	(+) 200 500
SUB TOTAL	4000				(+) 400 000
Nose wheel	220	x	(-) 50	=	(-) 11 000
TOTALS	4220				(+) 389 000

$$\frac{\text{TM}}{\text{TW}} = \frac{389\,000 \text{ lb in}}{4220 \text{ lb}}$$

= (+) 92.180 in aft of the reference datum.

Accordingly, the Weight and Centre-of-Gravity Schedule will state:

Basic Weight	:	4220 lb
Centre-of-Gravity	:	92.180 in aft of the reference datum
Total Moment about the datum	:	3890 lb in/100.

5.7 Weighing on Aircraft Jacks

5.7.1 It is important when weighing aircraft on jacks to strictly observe the procedures specified by the relevant aircraft manufacturer. Reference should also be made to Leaflet G-10 – Aircraft Handling. Suitable adapters should be fitted to the aeroplane jacking points and the weighing units of adequate capacity fitted to jacks. The jacks should then be positioned under each jacking point, and the zero indication of the weighing units verified. The attitude of the aeroplane should then be checked by means of levels or plumb bobs as appropriate. The aeroplane wheel brakes should then be released and the jack situated at the lowest jacking point raised until the aeroplane is level. The remaining jacks may then be raised to contact their respective jacking points. All jacks should then be raised slowly together (maintaining a level attitude) until the aircraft wheels are clear of the ground. When final adjustments have been made to level the aircraft, readings should be taken from each weighing unit, after which the aircraft may then slowly be lowered to the ground. To ensure that representative readings are obtained when using hydrostatic units or load cells, it is essential that a second weighing is carried out.

NOTE: When electrical weighing cells are being used it is often recommended that they should be switched on 30 minutes before commencing weighing operations, in order that the circuits have time to stabilise.

5.7.2 The weight and c.g. of the aeroplane can then be calculated as in the example given below, for an aircraft whose c.g. reference datum is quoted as fuselage station zero and on which the jacking points are situated at 50 and 180 in aft of the datum.

$$\text{c.g.} = \frac{\text{Total Moment (TM)}}{\text{Total Weight (TW)}}$$

		Weight (lb)		Arm (in)		Moment (lb in)
a)	Left jack reaction	1995	x	(+) 50	=	(+) 99750
b)	Right jack reaction	2005	x	(+) 50	=	(+) 100250
c)	Tail jack reaction	900	x	(+) 180	=	(+) 162000
TOTAL		4900				(+) 362000

$$\begin{aligned} \text{c.g.} &= \frac{\text{Total Moment (TM)}}{\text{Total Weight (TW)}} = \frac{362\,000 \text{ lb}}{4900 \text{ lb}} \\ &= 73.88 \text{ in} \end{aligned}$$

Accordingly, the Weight and Centre-of-Gravity Schedule will state:

Basic Weight	:	4900 lb
Centre-of-Gravity	:	73.88 in aft of the reference datum
Total Moment about the datum	:	3620 lb in/100.

5.8 Weighing Rotorcraft

- 5.8.1 Rotorcraft are normally weighed in a similar way to fixed-wing aircraft, four jacking points being located in the fuselage near the wheels. The c.g. datum is, however, normally located on the vertical line through the centroid of the main rotor and is marked on the side of the fuselage. Moments may therefore be either positive or negative and the permissible c.g. range extends either side of the datum.
- 5.8.2 The hydrostatic weighing of rotorcraft by the single point method can be used when permitted by the manufacturer. The process consists of suspending the craft from a single hydrostatic weighing unit at the rotor head. The c.g. is determined by measuring defined angles, and then entering the results into tables supplied by the manufacturer.
- 5.8.3 To ensure that the rotor blades are symmetrically located about the rotor axis, it is usually necessary to fit locks to the rotor head. The weight of these locks must be taken into account when calculating the c.g. position.
- 5.8.4 On some rotorcraft it may also be necessary to determine the vertical and transverse positions of the c.g., and the manufacturer's instructions regarding the method of calculation should be followed.

5.9 Standard Mean Chord

Since the c.g. is an aerodynamic consideration, its position is sometimes additionally specified as a percentage of the Standard Mean Chord (SMC) of the wing, measured aft from the leading edge (see paragraph 2.8.3 e)). The percentage SMC may be calculated as follows:

$$\frac{A - B}{C} \times 100$$

Where A = distance of the c.g. from the reference datum

B = distance of the SMC leading edge from the reference datum

C = the length of the SMC.

For example:

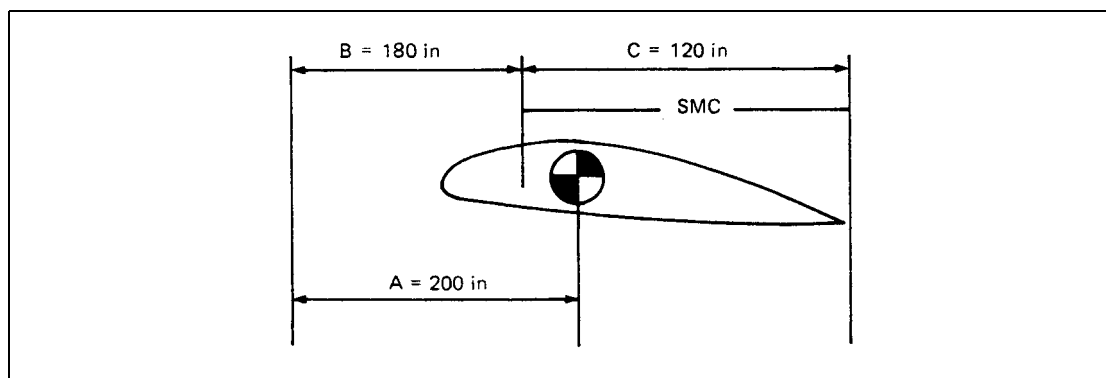

Figure 11 Standard Mean Chord

$$\begin{aligned} \therefore \frac{A - B}{C} \times 100 &= \frac{200 - 180}{120} \times 100 \\ &= \frac{20}{120} \times 100 \\ &= 16.6\% \end{aligned}$$

6 Change in Basic Weight

6.1 General

When an item of Basic Equipment is added, removed or repositioned in an aircraft, calculations must be made to determine the effect on both Basic Weight and c.g. This information should then be used to prepare a revised Weight and Centre-of-Gravity Schedule – Part A (see paragraph 2.9).

6.2 Modifications

Where the total weight and moment for additional equipment is not quoted in the appropriate Modification Leaflet, the equipment, and any parts used for attachment purposes, such as brackets, nuts, bolts, rivets, sealant, etc. must be accurately weighed. The position of the additional material must then be determined, and its moment calculated relative to the c.g. datum.

6.3 In order to find the new Basic Weight and moment of the aircraft, the weight and moment of the equipment added or removed must be considered in relation to the original Basic Weight as follows:

- a) When equipment has been added the weight must be added to the original Basic Weight; if the arm of the new equipment is positive (i.e. aft of the c.g. reference datum) then the moment must be added to the original moment, whereas if the arm is negative (i.e. forward of the c.g. reference datum) then the moment must be subtracted from the original moment.
- b) When equipment has been removed the weight must be deducted from the original weight; if the arm of the equipment was positive then the moment must be deducted from the original moment, whereas if the arm was negative then the moment must be added to the original moment.
- c) The new c.g. position is calculated by dividing the new total moment by the new basic weight.

NOTE: It may be found convenient to use mathematical signs to confirm the final action in the above calculations. For example, if equipment is added '+' and its arm is positive (+), since $+ \times + = +$, then its moment must be added to the original moment, but if equipment is removed '-' and its arm was positive (+), since $- \times + = -$, then its moment must be subtracted from the original moment.

6.4 Examples of Alterations to Basic Weight

6.4.1 The following examples are for an aeroplane whose:

- a) Basic Weight is 15 700lb,
- b) c.g. reference datum is at fuselage station 105, i.e. 105 in aft of fuselage station zero,
- c) c.g. is at station 130 i.e. + 25 in aft of the reference datum.

6.4.2 Example 1

A radar system is installed in the aeroplane which comprises:

- a) a radar set which weighs 32 lb and is located aft of the reference datum at fuselage station 125, with
- b) a controller which weighs 2 lb and is located at fuselage station 65, forward of the reference datum, and
- c) a scanner which weighs 25 lb and is located at fuselage station 12, forward of the reference datum.

			Weight (lb)	Arm (in)	Moment (lb in)
Original aircraft			15700	(+) 25	(+) 392500
Added items	(a)	+	32	(+) 20	(+) 640
	(b)	+	2	(-) 40	(-) 80
	(c)	+	25	(-) 93	(-) 2325
<hr/>					
Revised Basic Weight and moment		+	15759		(+) 390735

With the revised Basic Weight and moment the c.g. can be calculated as follows:

$$\begin{aligned}
 \text{c.g.} &= \frac{TM}{TW} \\
 &= \frac{390\,735}{15\,759} \\
 &= 24.79 \text{ in.}
 \end{aligned}$$

Accordingly, the Weight and Centre-of-Gravity Schedule will state:

Basic Weight	:	15 759 lb
Centre-of-Gravity	:	24.79 in aft of the reference datum
Total Moment about the datum	:	3096 lb in/100.

6.4.3 Example 2

The aeroplane's heating and air conditioning unit is removed from fuselage station 65 to fuselage station 180.

			Weight (lb)	Arm (in)	Moment (lb in)
Original aircraft			15700	(+) 25	(+) 392500
Item removed			- 120	(-) 40	(+) 4800
Item replaced			+ 120	(+) 75	(+) 9000
<hr/>					
Revised Basic Weight and moment			+ 15700		(+) 406300

With the Basic Weight unchanged and a revised moment the calculations are as follows:

$$\begin{aligned} \text{c.g.} &= \frac{\text{TM}}{\text{TW}} \\ &= \frac{406\,300}{15\,700} \\ &= 25.87 \text{ in.} \end{aligned}$$

Accordingly, the revised Weight and Centre-of-Gravity Schedule will state:

Basic Weight	:	15 700 lb
Centre-of-Gravity	:	25.87 in aft of the reference datum
Total Moment about the datum	:	4063 lb in/100.

7 Loading of Aircraft

7.1 General

In accordance with the Air Navigation Order, the Commander of an aircraft registered in the United Kingdom, must be satisfied before the aircraft takes off, that the load carried is of such weight and so distributed and secured, that it may safely be carried on the intended flight. To ensure this, the Variable and Disposable Loads must be added to the Basic Weight and c.g. of the aircraft and the total weight and c.g. determined. If the aircraft exceeds 5700 kg MTWA or has a seating capacity of 12 or more persons, the loading is based on assumed weights for persons and baggage, otherwise the actual weights must be used. For further information see Air Navigation Order (General) Regulations.

7.2 Small Aircraft

7.2.1 On small aircraft the calculations are fairly simple since the only item which alters appreciably during flight is the fuel quantity. Calculations should include all the variable and disposable items, at both maximum and minimum fuel states, to ensure that the c.g. will remain within the limits as fuel is used up.

NOTE: To minimise the calculations involved, some aircraft Operating Manuals include a graph of the c.g. limitations in the form of a weight/moment envelope.

7.2.2 On some aircraft the loadings which will give the maximum forward and aft c.g. positions are included in the weight and balance data. For example, on most four seat aircraft the maximum forward c.g. position is reached with the pilot only, no baggage and minimum fuel, and the maximum aft c.g. is normally obtained with pilot and two rear seat passengers, maximum baggage and maximum fuel. Provided these loadings are within limits it will not normally be necessary to calculate weights and moments before each flight. However, in the fully laden condition the maximum weight or aft c.g. limits may be exceeded, therefore, it may be necessary to offload passengers, baggage or fuel, depending upon requirements of a particular flight.

7.3 Large Passenger and Cargo Aircraft

7.3.1 With large aircraft the moment of items such as fuel, passengers and cargo are considerable and the procedures for determining a particular loading become complicated. In addition to the longitudinal c.g. calculation it is also usually necessary

to ensure that distribution of fuel and cargo is satisfactory in a transverse (lateral) direction. Most airlines employ a specialist section dealing with loading calculations, whose responsibility it is to produce a load sheet for each flight.

- 7.3.2 The main item of variable moment during flight is the fuel, and although correct management of the fuel system will minimise c.g. movement, some variations will remain due to the impracticability of locating all fuel near the c.g. on modern swept-wing aircraft. The critical points in the c.g. envelope are caused by fuel usage and variations in specific gravity, these variations are calculated and applied to the envelope to curtail its boundaries.
- 7.3.3 The c.g. limitations are further curtailed by fixed allowances for other variable items such as the following:
- a) Seating allowance, which is calculated to provide for out-of-balance seating loads resulting from empty seats or passenger weight variation.
 - b) Flight allowance, which is provided to allow for the normal movement of crew and passengers during flight.
 - c) Moment changes due to operation of the landing gear or flaps.
- 7.3.4 Weights and moments of passengers and cargo are then calculated, the cargo being arranged within the fuselage or holds in such a way that the total weight and moment of the loaded aircraft fall within the curtailed limitations. The heavier pieces of cargo or pallets are normally located close to the c.g. to restrict their effect, due attention being paid to floor loading limitations, strength and number of lashing points, etc.
- 7.3.5 On some aircraft it is also necessary to predetermine the order of loading fuel, cargo and passengers, in order to ensure that the structural limits are not exceeded, by excessive out-of-balance forces tending to tip the aircraft on its tail.
- 7.3.6 A Load Sheet, similar to the one shown, is prepared for each flight, the weights and moments with zero fuel and maximum fuel being entered in the c.g. envelope to ensure satisfactory balance and performance throughout all phases of flight, i.e. take-off, climb, cruise and landing.

Table 1 Typical Load Sheet

	Weight (lb)	Arm (in)	Moment (lb in/1000)	CG (% SMC¹)
Basic Weight	100 000	210	21 000.00	29.2
Variable Load				
Pilot	165	100	16.50	
Navigator	165	100	16.50	
Engineer	165	120	19.50	
Steward	165	300	49.50	
Crew baggage	100	110	11.00	
Passenger seats, 50 1st class	450	170	76.50	
100 tourist	600	280	168.00	
Drinking water	250	130	32.50	
Liferaft	300	410	123.00	
Emergency transmitter	30	120	3.60	
Service equipment (food, etc.).	200	400	80.00	
Operating Weight	102 590	211	21 596.60	30.0
Disposable Load				
Passengers 1st class (35)	5 775	160	924.00	
Tourist (83)	13 695	270	3 697.65	
Cargo No. 1 hold.	500	100	50.00	
No. 2 hold.	450	200	90.00	
No. 3 hold.	500	280	140.00	
No. 4 hold.	400	350	140.00	
Zero Fuel Weight.	123 910	215	26 638.55	33.3
Fuel Nos 2 and 4 tanks	10 000	150	1 500.00	
Nos 1 and 3 tanks	10 000	200	2 000.00	
Reserve tanks	5 000	240	1 200.00	
Take-off Weight	148 910	210	31 338.55	29.22

1. SMC is explained in paragraph 5.9. In this example % SMC is derived from the formula. $\frac{(c \cdot g \cdot arm - 175) \times 100}{120}$ (i.e. length of the SMC is 120 in and its leading edge is 175 in aft of fuselage station zero).

APPENDIX**Typical Weight and Centre-of-Gravity Schedule**

Reference	:	NAL/286
Produced by	:	Loose Aviation Ltd
Aircraft Designation	:	Flynow 2E
Nationality and Registration Marks	:	G-BZZZ
Manufacturer	:	FLY Co Ltd
Manufacturer's Serial	:	44
Maximum Total Weight Authorised (MTWA)	:	7300 lb
Centre-of-Gravity Limits	:	Refer to Flight Manual Reference Number 90/946

Part 'A' Basic Weight

The Basic Weight of the aircraft (as calculated from Weight and Balance Report/Weighing Record NAL/W/95¹ dated 31 August 1977) is : 5516 lb

The c.g. of the aircraft (in the same condition at this weight and with the landing gear extended) is : 127 in aft of datum

The total moment about the datum in this condition in lb/100 is : 7015

NOTE: The datum is at fuselage station 0 situated 114 in forward of the wing leading edge. This is the datum defined in the Flight Manual. All lever arms are distances in inches aft of datum.

The Basic Weight includes the weight of 5 gallons of unusable fuel and 1 gallon of unusable oil and the weight of the following items which comprise the list of Basic Equipment:

Item	Weight (lb)	Lever Arm (in)
2 Marzell propellers type BL-H3Z30	127 each	76
2 engine driven 100 ampere alternators	27 each	117
1 13 Ah Ni-Cd battery CB-7 etc.	31 etc.	153 etc.

Part 'B' Variable Load

The weight and lever arms of the Variable Load are shown below. The Variable Load depends upon the equipment carried for the particular role.

Item	Weight (lb)	Lever Arm (in)	Moment (lb in/100)
Pilot (one)		108	
De-icing fluid 1 ¹ / ₂ gal	12	140	17
Life-jackets (seven)	14	135	19
Row 1 passenger seats (two)	60	173	104
Row 2 passenger seats (two)	60	215	129
Row 3 passenger seats (two)	60	248	149
Table	8	256	20
One stretcher and attachments (in place of seat rows 2 and 3)	45	223	100
Medical stores	15	250	37

1. Delete as appropriate

Part 'C' Loading Information (Disposable Load)

The total moment change when the landing gear is retracted in lb in/100 is: -18. The appropriate lever arms are:

Item	Weight (lb)	Lever Arm (in)	Capacity (imp gal)
Fuel in tanks 1 and 2	1368 ¹	145	190
Engine oil	50 ¹	70	5.5
Forward baggage		21	
Rear baggage		261	
Passengers in Row 1 seats		171	
Passengers in Row 2 seats		213	
Passengers in Row 3 seats		246	
Patient in stretcher		223	

1. Densities – Petrol 7.2 lb/imp gal; kerosene 8.1 lb/imp gal; Oil 9.0 lb/imp gal.

NOTE: To obtain the total loaded weight of the aircraft, add to the Basic Weight and the weights of the Variable and Disposable Load items to be carried for the particular role.

This Schedule was prepared (date).....and supersedes all previous issues.

Signed Inspector/Engineer

on behalf of

Approval reference

NOTE: (Not part of the Example Schedule). In Part 'B' Variable Load of this Schedule, the actual weight of the pilot is required in accordance with the Air Navigation (General) Regulations for aircraft the (MTWA) of which does not exceed 5700 kg or with less than 12 persons seating capacity. Hence the pilot's weight and moment are omitted in the example.

INTENTIONALLY LEFT BLANK

Chapter 12 Servicing – Routine Maintenance

Leaflet 12-10 Cleanliness of Aircraft

1 Introduction

The degree of cleanliness achieved, both internally and externally, during the manufacture and maintenance of aircraft has a direct bearing on airworthiness. To ensure that engineers and inspectors are able to certify that aircraft are fit for flight, it is essential, particularly where closed structures are concerned, that the component history cards and aircraft build sheets used during manufacture and overhaul, should contain a clause requiring inspection to certify that each part has been inspected at the appropriate stage and that it is free from loose articles, dirt, swarf and other extraneous matter.

2 The Effects of Extraneous Matter

The presence of extraneous matter inside aircraft, components, systems, etc., can have serious consequences and special care is necessary to ensure thorough cleanliness at all times. In the following paragraphs some of the adverse effects are briefly outlined.

- 2.1 Extraneous matter in the form of dirt or grit in moving parts may cause excessive wear and other damage. Working clearances of many components are relatively minute and small particles of dirt may cause scoring or seizure of working surfaces and rapid deterioration of seals and glands. Where systems are concerned (e.g. hydraulic, fuel and pneumatic systems), scrupulous cleanliness is essential during assembly and maintenance operations; contamination inside a system will often present a difficult cleaning problem and many cases are on record of malfunctioning due to ingress of extraneous matter.
- 2.2 The presence of loose extraneous articles inside a structure is always a dangerous hazard. Such items as nuts, bolts, rivets, off-cuts of wire or sheet metal and hand tools have been found inside the more intricate and boxed-in type of structures. These can cause jamming or restriction of vital controls and have been known to result in serious aircraft incidents. Furthermore, loose items, especially of a heavy nature, which are trapped inside structures can, due to vibration, erode the protective treatment of the structure and cause damage to bag-type fuel tanks or the sealant of integral tanks. Heavy loose items trapped inside control surfaces can result in their becoming unbalanced.
- 2.3 In structures where there are electrical installations, small metal particles can cause damage to the insulation of wires and looms and these can produce short-circuits at terminal points. The ingress of such particles into switches, solenoids, actuators, etc., is a common cause of malfunctioning. Where inverters, generators, etc., are cooled by means of ducted air, special care is necessary with regard to cleanliness as the cooling air can collect dust and grit and deposit this inside the component; foreign matter can also block the cooling-air filters of avionic equipment, resulting in overheating and failure.

NOTE: Loose particles of ferrous metal, such as filings, in the vicinity of electromagnetic mechanisms are particularly dangerous and difficult to remove; such mechanisms

should, therefore, be adequately protected prior to filing and sawing ferrous parts in the vicinity.

- 2.4 Where pipes run in banks, loose extraneous parts may become wedged into the pipe clearances and might restrict the natural whip or flexing of the pipes under surge loads, resulting either in fracture or perforation through chafing.
- 2.5 Grit or small metal particles inside bays fitted with flexible tanks will damage the tank envelope and produce leaks and, in the case of integral tanks, metal particles embedded in the tank sealant might cause leaks and promote corrosion of the structure from electrolytic action.
- 2.6 The presence of extraneous fluids, due to spillage or leaks, may have serious deleterious effects. Certain fluids, such as ester-base engine oil, hydraulic oil, glycol, de-icing fluid, etc., will damage most protective treatments or materials not intended to be in contact with these fluids, and bonding compounds, electric cables, rubber mouldings, tyres, etc., will deteriorate rapidly if these are left in contact with such fluids; the spillage or leaks of some fluids may increase the fire hazard, especially if they occur in the vicinity of electrical equipment or engine installations. Serious contamination can also be caused by spillages of toilet fluids, mercury, gallium and other chemicals.
- NOTE:** Leaflet G-20 gives guidance on general fire precautions.
- 2.7 In remote areas of the structure where access and periodic cleaning are difficult, dirt or dust will tend to accumulate and could act as a wick for moisture which in time, may penetrate the protective treatment and promote corrosion.
- 2.8 Special precautions are required regarding oxygen installations. The presence of extraneous matter, especially of an oily or greasy nature, in contact with pressure oxygen is explosive. It is important, therefore, to follow the special instructions regarding cleanliness of oxygen systems given in the installation drawings or Maintenance Manual.

3 General Precautions

It will be difficult to ensure a high standard of cleanliness of aircraft, components, etc., unless a similar standard is maintained in hangars and workshops. Vigilance is necessary to ensure that conditions and workshop practices are such that extraneous matter will not enter or come into contact with any part of the aircraft, its systems or its components.

NOTE: It is recommended that placards and warning notices (preferably illustrated), pointing out the seriousness of extraneous matter in aircraft, should be placed in all departments.

- 3.1 In order to prevent small tools, torches, pencils, etc., from falling into the aircraft structure, personnel engaged on servicing operations should wear overalls fitted with closed pockets. Suitable footwear should also be provided, or vulnerable surfaces should be protected with mats, as even small scratches can destroy anti-corrosive treatment and lead to deterioration of a component.
- 3.1.1 An inventory should be made of all tools, spares or equipment taken to an aircraft for servicing purposes, and checked when the work has been completed. This action will reduce the possibility of such items being left in the structure.
- 3.2 Dirty floors, stagings, benches, test equipment or open tins of jointing compound, sealants, grease, paint, etc., (which may gather extraneous matter), should not be permitted. For instance, no matter how careful an engineer might be regarding the

final cleanliness of a component he may not be able to detect the presence of extraneous matter in jointing compound from a tin that has been left open; yet this may result in a serious attack of electrolytic corrosion or prevent the joint from closing completely. All tins and containers should be kept closed when not in use and any tins and containers which have been open for an unknown length of time should be discarded.

NOTE: This trouble can be avoided if the compound is obtained from squeeze tubes and applied directly to the joint.

- 3.3 Engines, accessories, instruments, ball bearings, etc., which are usually supplied, as appropriate, in special transport cases or packagings, should not be unpacked until required for use. Blanking plates on engines or components and blanks fitted to pipe connections or other openings, should only be removed for installation or functioning tests.
- 3.4 Parts that are not required for immediate installation should be kept in stores. For information on storage conditions for aeronautical supplies, see Leaflet D-40.
- 3.5 Whenever it is necessary to open or dismantle an accessory, component or system, the work should be done under controlled conditions where dust, grit, etc., (e.g. from cleaning operations), cannot enter the accessory, component or system. Stripping and cleaning sections should be adequately segregated from inspection and assembly areas.
- NOTE:** Care is necessary when using sawdust for cleaning hangar floors. Cases have arisen during maintenance work on fuel systems where the lighter particles of sawdust had entered the system and subsequently been found in the fuel filters. Investigation revealed that these particles emanated from the sawdust used for cleaning purposes.
- 3.6 Transparent plastics panels (acrylic sheet), widely used for cabin window glazing, are affected by certain organic fluids and in some cases their vapours. Some of these fluids are in common use during aircraft maintenance operations and cleaning procedures.
- 3.7 Engine runs should be carried out at some distance from maintenance installations or other aircraft, on hardstandings with clean, firm and well drained surfaces. This will minimise damage to external parts of the aircraft and help to prevent water, grit or debris from entering engine intakes, breathers and vents.

4 Aircraft in Service

When an aircraft is in service it should be cleaned periodically as part of the routine maintenance aligned with a Maintenance Programme, or may be separately controlled. The cleaning solvents recommended for use on a particular aircraft are usually detailed in the relevant Maintenance Manual but in any case no unauthorised solvents or detergents should be used. Chlorinated solvents such as trichlorethylene or carbon tetrachloride should not be used inside the aircraft due to the danger of toxic fumes given off by these liquids.

4.1 Normal Exterior Cleaning

Before commencing cleaning operations all panels and covers should be in place and apertures sealed off. Thick mud, grease or oil should be removed by, first, hand scraping using wood or soft plastic scrapers and then lint-free cloth soaked in solvent. Care should be taken to avoid damage to paint or other anti-corrosive treatment. Cleaning should then be carried out using a recommended solvent. These solvents are usually used diluted in hot water. Application to the aircraft surface is best made

with spraying equipment but care should be taken to ensure that the solution does not become atomised. After allowing the solution to penetrate, the dirty surface should be washed thoroughly with clean water until all traces of the solution are removed. Care should be exercised when using water hoses or pressure washers for rinsing as too high a pressure may cause damage or ingress of moisture. Undiluted solvents should never be allowed to come into contact with acrylic windows, etc., as crazing is likely to ensue. In all cases the recommended solvent manufacturer's instructions should be adhered to. Re-lubrication of mechanical parts may be necessary after washing, and application onto sealed bearings, etc., should be avoided.

4.1.1 **Exterior Cleaning of Heavily Contaminated Areas**

Certain areas of an aircraft may become heavily contaminated by exhaust gas deposits, the areas varying with different types of aircraft. This contamination, if not removed, could cause severe corrosion and require expensive repairs. Stronger cleaners recommended for the particular aircraft or part should be used with extreme care. Dilution may be required with either water or white spirit and application can be made with a non-atomising spray. In all cases, the solvent manufacturer's instructions must be strictly complied with. The solution, when applied, should be allowed to soak for a given period and care taken to avoid areas becoming dried out. After soaking, further application is usually required and agitation or scrubbing with a soft brush may be advantageous. Very thorough rinsing, preferably with clean warm water, is necessary. Painted surfaces as well as acrylic windows may become damaged if these stronger solutions are allowed to come into contact with them.

4.1.2 **Snow and Ice**

Chemical salts and other melting agents are often used on runways during the winter months. This slush will inevitably become splashed or sprayed onto the aircraft and could be detrimental. The contaminated areas should be washed down with clean water as soon as possible after exposure. The use of a wetting agent may prove helpful.

4.1.3 **Salt Air Operating Environments**

Aircraft operated in salt air marine environments will be more susceptible to associated detrimental effects caused by salt deposits and salt contaminant corrosion. Aircraft cleaning and protection programmes should be tailored accordingly for these operating environments and may include increased frequency of aircraft washing and lubrication procedures, engine compressor washing, etc.

4.1.4 **Acrylic Windows**

After aircraft washing, the windows should be washed with soap or a mild detergent in warm water. Polishing minor scratched surfaces may be accomplished with an approved plastics polish and finally finished with an anti-static polish or cloth.

4.1.5 **Radioactive Contamination**

This is usually confined to aircraft regularly flying above the stratosphere. Regular monitoring of high flying aircraft with a Geiger counter should be made. Normal regular cleaning will in most cases keep contamination within acceptable limits.

4.1.6 After cleaning of windows has been completed, the aircraft should be inspected for signs of damage, deterioration of protective treatment, cracks, corrosion, etc. A careful check should be made to ensure that all blanks and sealing fitted have been removed and that cleaning equipment such as rags, sponges, etc., are not left in the intakes, flying controls or other susceptible places. Vents and drain holes, etc., should be checked and cleared if necessary.

4.2 Interior Cleaning

The inside of the aircraft should be kept clean and special attention should be given to areas where spillages can occur. Dirt and grit are best removed by use of a vacuum cleaner but oil or grease stains should be removed with the aid of a cleaner recommended by the manufacturer. This should be applied in small quantities to prevent soaking the fabric or padding. Loose covers may be removed for washing but must be thoroughly dry before refitting in the aircraft. Where the materials have a non-permanent flame-proof protection they must be re-proofed after washing.

4.2.1 At the intervals prescribed in the appropriate Maintenance Schedule, the floor panels should be removed and an inspection of the underfloor skin and structure carried out. Corrosion and residues which result from spillages in the cabin, galleys or toilets should be removed, together with any extraneous material; if necessary, any corrosion-prevention treatment should be restored, and soaked or damaged insulation bags should be renewed. Debris may also be found in the compartments used for luggage and cargo.

4.2.2 Particular care is required when cleaning the cabins of pressurised aircraft since these tend to produce far more condensation than those of unpressurised aircraft. The moisture attracts dust and dirt and can quickly lead to corrosion of metal surfaces if the protective film is damaged. Dirt and grit could also lead to malfunction of the relief and vent valves used in the pressurising system and result in potentially dangerous cabin pressure conditions.

4.2.3 Plastic (polyester) foam may, under conditions where it is repeatedly moistened and dried, exude a mild acid capable of causing serious corrosion to aluminium alloys, particularly in poorly ventilated areas. Such plastic foam may have been used in the upholstery of seats and also in thermal/acoustic lining. If there is evidence of staining on such plastic it should be lifted to enable direct inspection of the adjacent seat frames or structure to be carried out. Appropriate action should be taken with the structure dependent upon the degree of attack, but, in any case, deterioration of the protective finish of the structure should be made good after thorough cleaning. Contaminated plastic foam should be renewed.

4.2.4 Carriage of Livestock

Very thorough internal cleaning is necessary after the carriage of livestock with particular attention being paid to the bilge areas. A disinfectant should be used recommended by the aircraft manufacturer. If any signs of vermin such as cockroaches, mice, etc., are found it may be necessary to contact the Health Authority to ascertain whether or not complete fumigation of the aircraft is necessary. Disinfestation is usually carried out by contractors who specialise in this work and complete ventilation of the aircraft is required afterwards for a period of several hours.

5 Parked Aircraft

All doors and windows should be closed, and covers and protective blanks should be fitted which are to stand for extended periods; this equipment often forms part of the aircraft flight kit, and is designed to protect air intakes, ducts, vents, pitot heads, etc., from ingress of extraneous matter.

5.1 Covers, blanks and other protective devices are usually interlinked by cords or fitted with warning streamers, to ensure that they are all removed when the aircraft is prepared for flight.

- 5.2 On turbine-engine aircraft, the air intake and jet pipe blanking covers should be fitted at all times when the aircraft is not in use, and only removed for maintenance purposes or engine runs when special engine running guards might be necessary.

NOTE: Dependent on the length of time out of service, the engine may require rotating or inhibiting in accordance with the instructions in the engine Maintenance Manual.

- 5.3 When aircraft are to be 'parked out' for long periods, special precautions in addition to those normally given in the Maintenance Manual will be required, and the manufacturer's advice should be sought.

6 Cleanliness of Airframe Structures and Components

The task of ensuring cleanliness should begin at the initial assembly stage, even though further work may be required before final assembly is completed.

NOTE: Boxes or special trays should always be used for small items, such as hand tools, AGS parts, etc., which are to be used on aircraft. Items left loose on the aircraft or adjacent trestles and stagings, may fall into the structure undetected and result in serious incidents when the aircraft is in service. Supervision should also ensure that refreshments (e.g. mineral-waters, tea, etc.) are not taken onto the aircraft as spillages of these are common causes of corrosion.

- 6.1 Components such as flying control surfaces, wings, tail units and boxed-in structures should be inspected progressively for cleanliness. When a structure is to be closed, either permanently or by a removable panel, inspection should verify that the compartment is entirely free of extraneous matter. The inside of structures or components should be inspected for cleanliness using the visual aids and methods outlined in Leaflet 51-50 which gives guidance on the internal inspection of structures.

NOTE: If any part of the aircraft or engine control system is inside a closed-in compartment, consideration should be given to the requirements for duplicate inspections detailed in BCAR Chapter A6-2.

- 6.2 Large modifications, skin repairs, spar changes, etc., involve the production of large quantities of swarf, redundant parts and sealant; as much debris as possible should be removed as it is produced but a proper cleaning programme should also be implemented. A thorough inspection should be carried out on the internal structure before it is sealed. When the work involves fuel compartments the low pressure filters and booster pump screens should be checked after filling the tanks and again after initial engine runs.
- 6.3 The method of cleaning will be governed to some extent by size and structural features, but where possible the smaller structures such as ailerons, flaps, etc., should be rotated in all directions and shaken to dislodge any items which might be trapped or retained inside. In instances where normal cleaning is not possible, full use should be made of powerful vacuum cleaners with suitable adaptors. The use of an air jet as a cleaning medium is not recommended, since in the main it merely succeeds in distributing the extraneous matter over a wider area, sometimes into freshly cleaned compartments and may drive unwanted particles into lap joints, bearings or electrical components. Compressed-air supplies frequently have a high moisture content and their use in inaccessible places could lead to corrosion.
- 6.4 The final inspection should be made when there is no likelihood of the compartment being reopened, except of course for assembly purposes and test flight adjustments etc. when it is certain that no further operations are necessary which might introduce extraneous matter into the compartment. Compartments which are re-opened should

be given further careful examination after the work which necessitated re-opening has been completed.

NOTE: Radiography is often used to examine boxed-in structures which have been progressively inspected for cleanliness, but there may be small openings through which rivets or other small items could have gained access during work on adjacent structures.

- 6.5 On completion of the work, the engineer, having satisfied himself that the structure or component is perfectly clean, should witness its closing and endorse this inspection stage on the related history card.
- 6.6 Most aircraft have provision in the lower surfaces of the fuselage, wings, control surfaces and cowlings for the drainage of accumulated fluids, normally water. Some of these can be fully effective only when the particular structure is correctly positioned, e.g. stabilisers set to 'Aircraft nose-down trim position'. Engineers should therefore ensure that such drainage features are clear and effective when the aircraft is parked and at all times during maintenance.

7 Cleanliness of Installations and Systems

Compartments into which engines, etc., are to be installed should be thoroughly cleaned immediately prior to the installation.

- 7.1 During the installation, all connections should be examined for cleanliness and freedom from obstruction immediately prior to fitting. Any items, such as nuts, bolts and washers, which are dropped should be recovered immediately and not left until the installation is complete, since by that time the incident may be forgotten.
- 7.2 On completing the installation and immediately prior to closing the compartment, a careful final examination should be made of the compartment and installation and of any associated cooling ducts, panels, controls, etc., to ensure complete freedom from loose articles and other matter.
- 7.3 Electrical multipin plugs and sockets, which are extensively used in engine installations, are particularly susceptible to trapping of fine swarf or dirt and this can easily lead to electrical faults of a type very difficult to trace. When not coupled up, all multipin plugs and sockets should be suitably protected.
- 7.4 On completion of engine installations, inspection should verify that engine bays are clean and free from loose articles. Care should also be taken to ensure that drains are clear so that no accumulations of fuel or oil can be trapped in cowlings. Where temporary covers or blanks are fitted to turbine engines, inspection should ensure that covers and blanks are of the correct type, are clean and have no loose parts which, if detached, could enter the air intakes.
- 7.5 The cleanliness of all systems such as hydraulic, pneumatic, fuel systems, etc., cannot be overemphasised. This applies not only to the systems installed or being installed in the aircraft, but also to any related ground equipment (see paragraph 9).
- NOTE:** Guidance on cleanliness procedures for systems is given in the following Leaflets:
20-50 Hose and Hose Assemblies,
20-60 Installation and Maintenance of Rigid Pipes,
32-20 Wheels Brakes.
- 7.5.1 Whenever an orifice or connection in a system has to be left open, protection against the entry of extraneous matter must be provided by means of blanks or specially-made covers.

- 7.5.2 The design of blanks and covers is very important. In many cases standard AGS blanks are used in the form of plugs or caps, but where a non-standard orifice are concerned, it is often necessary to make a special cover, in which case the design and choice of material must be carefully considered. Cotton and other textile materials should not be used because of danger of small particles of fluff entering the system. For the same reason, paper, wood or cork should be avoided, as small fragments of these materials may become detached and enter the system. Blanks should be so designed that it is impossible to connect up the system with a blank in position.
- 7.5.3 For short-term protection, especially in the case of a group of open connections such as a junction block, a polythene bag tied over the unit is often used. However, where plastics protective devices are concerned, it is important that they are not used on systems the fluids of which may have an adverse effect on the plastic material. The possibility of slivers of plastic being cut by engagement with a metallic coupling and gaining entry into a component should also be considered.
- 7.5.4 Wear of control cables is accelerated very considerably where dirt clings to surplus grease or protective films on the surface of control cables where they pass through fibre, tufnol or ferrobestos fairleads and over pulleys. It is therefore important that lubricants or sticky protective films to which dirt might adhere are removed from cables in positions where wear may take place. This should be done by wiping with a cloth and not by washing with solvents or detergents.

8 Cleanliness of Complete Aircraft

Prior to the final inspection of a new or overhauled aircraft, inspection should verify that all boxed-in compartments have been checked for internal cleanliness.

- 8.1 Special attention should be given to compartments which have been opened for the purpose of adjustments; all sections through which engine and flying controls pass; the cockpit and associated equipment; landing gear bays and the landing gear.
- 8.2 The cleanliness of warning notices, data plates, transparent covers of notices or indicators and instruments should also be checked.
- 8.3 On completion of the inspection, the engineer, having satisfied himself that the aircraft is clean, should endorse this inspection stage on the aircraft history sheet.

NOTE: It is good practice to carry out a final inspection for loose articles immediately following the first flight after manufacture or overhaul.

9 Ground Equipment

The cleanliness of ground equipment is important, particularly in respect of test rigs which are connected into an aircraft system.

- 9.1 The degree of filtration demanded in modern fuel and hydraulic systems is such that particles which are not visible to the naked eye are capable, if not filtered out, of causing malfunction of a component. It is therefore, most important that the filtering arrangements included in the test rig should be at least equal to those in the system itself. Before using a rig the connections should be thoroughly cleaned and when not in use the hoses should be blanked off and properly stowed.
- 9.2 Mobile dispensers used for fuel, oil, de-icing fluids, etc., must be kept clean and all covers and blanks should be fitted when the equipment is not in use.
- 9.3 Regular checks should be made for water contamination in fuel dispensers and in bulk storage.

Chapter 20 Standard Practices – Airframe

Leaflet 20-10 Torque Loading

1 Introduction

- 1.1 The purpose of this Leaflet is to provide guidance and advice on the torque loading of threaded fasteners to ensure efficient clamping of mating parts and prevent overstressing.
- 1.2 The subject headings are as follows:

Paragraph	Subject	Page
1	Introduction	1
2	General	1
3	Recommended Techniques	1
4	Torque Wrenches	3
5	Checking of Torque Wrenches	6

1.3 Related Leaflets:

51-110 Assembly and Maintenance of Critical Bolted Joints

2 General

- 2.1 The majority of nuts, bolts and set screws on an aircraft are subject to a standard torque value, depending on their material, finish, lubrication, thread type and size, but particular applications may necessitate a different torque loading and this will be specified in the Appropriate Maintenance Manual. The normal method of applying a torque loading to a fastener is by means of a torque wrench, but in some critical bolted joints the use of pre-load indicating (PLI) washers may be specified and these are discussed in Leaflet 51-110.
- 2.2 'Standard' torque loading values are those generally applied to steel fasteners used in tension applications on aircraft. Lower values are generally quoted for shear nuts or nuts used in shear applications. Lower torque values are also necessary for pipe union nuts (bearing in mind the actual thread size and not the pipe diameter). 'Special' torque loadings may be used for a variety of reasons, examples of which are the loadings applied to the bolts fitted to flexible engine mountings and those applied to non-standard fasteners such as cylinder holding-down nuts.

3 Recommended Techniques

- 3.1 Torque loading instructions in Aircraft Maintenance Manuals will be found to vary slightly between different aircraft and engines. Most manufacturers specify

lubricated torque values, i.e. the threads and all mating surfaces lightly lubricated with oil, sealant or anti-seize compound as appropriate, but some manufacturers specify dry torque values, i.e. parts clean and dry or as pre-lubricated during manufacture. Due to the varying effects of friction under different conditions of assembly, it is important that the torque applied to any particular fastener should be in accordance with the manufacturers instructions; the pre-load applied to a fastener at a specified lubricated torque would be considerably higher than if the same torque were applied dry.

3.2 Initial Assembly

In order to remove the roughness from threads and mating surfaces when assembling new components which require high torque loadings, the following procedure should be followed:

- a) Clean and where specified, lubricate threads and mating surfaces of nut, bolt and washer.
- b) Tighten nut to approximately half the specified torque value.
- c) Slacken nut then finally re-tighten to specified torque value.

NOTE: Where cadmium plated fasteners are used in locations subject to fluctuating loads, the manufacturer may recommend a different procedure.

- 3.3 Wherever possible, in a bolt-nut or screw-nut combination, the bolt or screw must be held stationary and the nut turned. When it is necessary to tighten a fastener from the bolt or screw side, the torque value must approach the high side of the specified range. Whenever torqued fasteners are to be secured by means of split pins or lock wire, the low side of the torque range must be used for tightening. If necessary, tighten the fastener so that the next slot aligns with the hole, provided the maximum torque value is not exceeded. If the maximum torque value is reached and the slot in the nut does not line up with the hole in the bolt, the nut and washer must be changed.

3.4 Sealants

When sealant is used in a joint, the torque loading of fasteners should be carried out within the application time of the sealant. After ten minutes, but within twice the application life of the sealant, the loading should be checked and re-applied as necessary.

3.5 Union Nuts

The component parts of a flared pipe coupling require bedding-in to ensure freedom from leaks and the following procedure should be adopted when tightening union nuts:

- a) Assemble the component parts of the joint and run-up the nut by hand.
- b) Tighten to specified torque value.
- c) Slacken the nut half a turn, then re-tighten to specified torque value.

- NOTES:**
- 1) Torque loading is not usually specified for flareless couplings. The procedure normally recommended is to tighten the nut using finger pressure until positive resistance is felt, then tighten a further one sixth to one third of a turn.
 - 2) Lubrication of components is usually by the type of fluid used in the system but connections in oxygen systems must be dry unless a special preparation is recommended.

3.6 **Stiffnuts**

In order to check the effectiveness of the friction element of a stiffnut, it is general practice to turn the nut onto its mating thread by hand. If it is possible to pass the thread through the friction element by hand, then the locking is unsatisfactory. However, certain manufacturers specify acceptable limits of 'in-built' or frictional torque for various thread types and sizes and in these instances, each stiffnut should be checked with a torque wrench before re-use.

3.7 **Torque Tables**

3.7.1 Tables of standard torque values for different thread types and sizes and for special applications, are normally found in the appropriate Maintenance Manual; separate tables often being included for ordinary nuts, stiffnuts, union nuts and studs. Manuals for older types of aircraft may be found to contain only special torque loading requirements and a single table applicable to non self-locking nuts; in these cases the frictional torque of a stiffnut must be added to the torque quoted for the type and size of thread.

3.7.2 Torque tables usually specify the upper and lower limits of torque for different types and sizes of fasteners, but if a single figure is quoted, it is generally accepted that this may be exceeded for the purpose of lining up a split pin hole, tab washer or locking plate. However, an upper torque limit should not be exceeded and nuts should never be slackened to line up these locking devices.

4 **Torque Wrenches**

4.1 There are basically two types of torque wrenches. One type contains a flexible beam which bends under load, the amount of bend being recorded on a dial which is graduated in units of torque. The second type contains a spring loaded ratchet device which may be preset before use and when this preset torque is reached, the wrench 'breaks' to prevent further tightening.

4.2 The torque applied to a nut is a function of the force applied to the wrench handle multiplied by the distance between the point of application of the force and the centre of the nut. This may be measured in appropriate units such as pounds inches (lb in), kilogramme centimetres (kg cm) or newton metres (Nm). The scale on the wrench is marked to show the torque applied to its driving tang, i.e. force applied to the handle multiplied by the distance between its driving tang and the centre of the hand grip.

4.3 If a torque wrench is used in conjunction with a socket type of spanner, the nut and tang centres will coincide and the torque applied to the nut may be read directly from the wrench scale. However, in some cases an extension spanner is used in conjunction with a torque wrench and the torque applied to the nut will be different from the torque shown on the wrench scale.

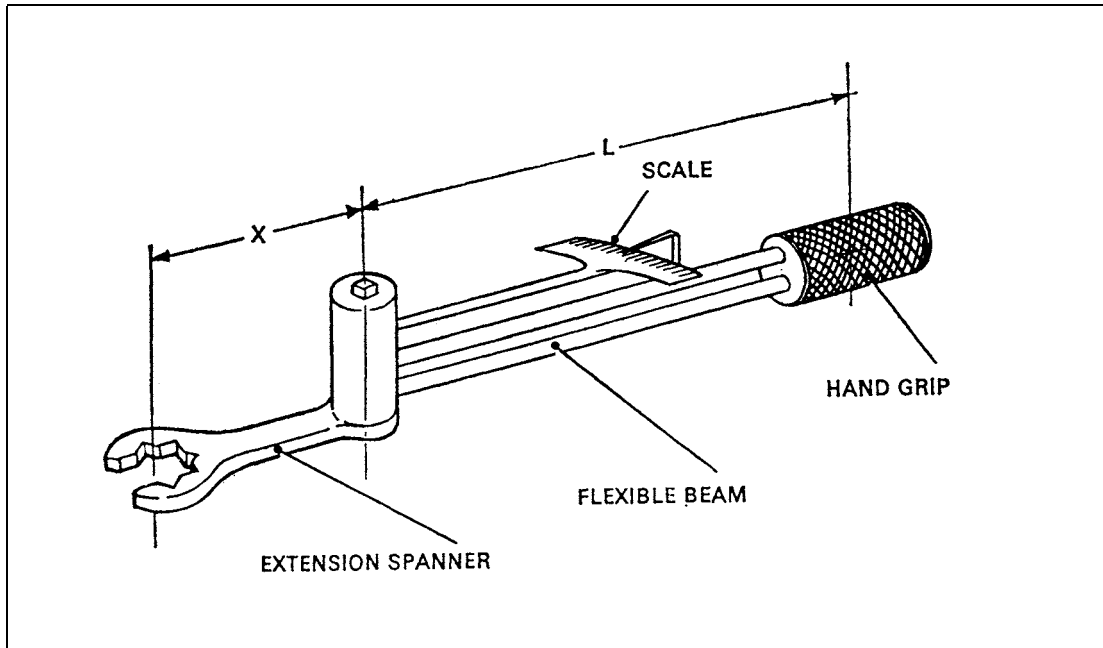

Figure 1 Typical Beam-type Torque Wrench

4.4 Extensions

- 4.4.1 Figure 1 shows a typical beam type torque wrench which has an extension spanner attached. If this combination is used to torque load a fastener then the following formula should be used to calculate the wrench scale reading which corresponds to the specified torque value:

$$\text{Scale Reading} = \text{specified torque} \times \frac{L}{L + X}$$

Where L = distance between the driving tang and the centre of the handle

X = length of extension spanner between centres.

- 4.4.2 A simple way of calculating the scale reading required without using the formula is set out in the following example, for which the specified torque loading is 300 lb in and the lengths of the wrench and spanner are 10 and 5 inches respectively.

- a) Force required on wrench handle to produce a torque of 300 lb in is, 300 lb in divided by the distance between nut and wrench handle,

$$\text{which is, } \frac{300 \text{ lb in}}{10 \text{ in} + 5 \text{ in}} = 20 \text{ lb}$$

- b) Scale reading when force on handle is 20 lb is, 20 lb x 10 in = 200 lb in.

Force must therefore be applied to the wrench handle until a reading of 200 lb in is shown on the wrench scale, and this will represent a 300 lb in torque load applied to the nut. With the 'break' type wrench, the adjustment must be preset at 200 lb in.

NOTE: For the purpose of conversion, 1 lb in = 1.15 kg cm or 0.113 Nm.

- 4.4.3 When using an extension spanner with a torque wrench, the spanner and wrench should be as nearly as possible in line. If it is necessary to diverge by more than 15° from a straight line (due for example to an intervening structure), then the direct distance (D) between the nut and wrench handle must be substituted for 'L + X' in the formula (paragraph 4.4.1) for calculating wrench scale reading. This is shown in Figure 2, and the scale reading in this instance will be equal to specified torque $\times \frac{L}{D}$

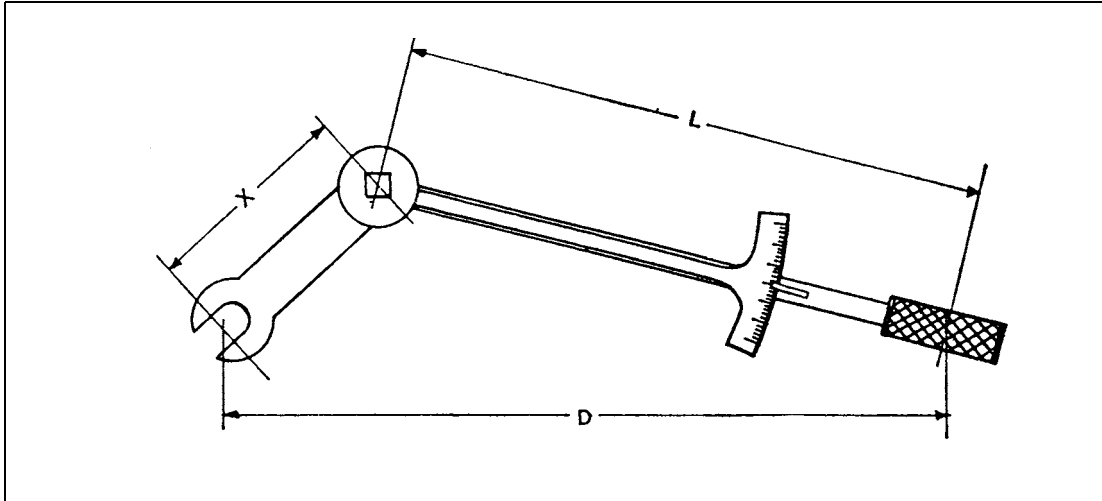

Figure 2 Alternative Method Of Use

- 4.4.4 Whenever a torque wrench is used, it must be confirmed that the specified torque and the wrench scale are in the same units; if not, then the specified torque should be converted, by calculation, to the units shown on the wrench scale, and any measurements taken in appropriate units.
- 4.4.5 When applying torque the wrench handle should be lightly gripped and force applied smoothly at 90° to the axis of the wrench.
- 4.5 **General Considerations**
- 4.5.1 Values of torque within the first quarter of the wrench scale may be difficult to read accurately, and some manufacturers specify that the torque wrench selected for a particular use should have a range such that the specified torque falls within the upper range of the scale.
- 4.5.2 When using a ratchet type wrench with a floating drive (i.e. a driving tang which is located in a socket in the wrench and is moved axially through the socket to reverse the direction of operation of the wrench), it is important to ensure that the wrench is used the right way round. If incorrectly used, severe overstressing of the fasteners could occur before the error is noticed.
- 4.6 **Over-Torqued Fasteners**

Fasteners which have been tightened beyond the maximum specified torque value must be removed, rendered unserviceable and scrapped. In the case of over-torqued bolt-nut or screw-nut fasteners, both bolt or screw and nut must be discarded.

NOTE: Over-torqued fasteners must not be backed off and retorqued to the correct value due to possible internal damage to the material structure and the increased likelihood of fatigue failure in service.

4.7 **Retorquing**

Where it is necessary to retorque a fastener assembly, the nut must be backed off part of a turn and re-tightened to the specified value. Unless the installation requires the torque to be applied to the bolt or screw in the first instance, the bolt or screw must be supported and not be allowed to turn during a retorquing operation.

5 Checking of Torque Wrenches

- 5.1 Beam-type torque wrenches should be checked before use to ensure that the scale reading is zero.
- 5.2 All torque wrenches should be checked for accuracy preferably before use or at intervals normally not exceeding 6 months. However, for those torque wrenches subject to greater use, checks for accuracy should be carried out at more frequent intervals. If a spring balance is attached to the centre of the wrench handle, and force applied tangentially to the arc of movement, the wrench scale reading should correspond to the spring balance reading multiplied by the wrench length. Checks should be made at several values within the wrench scale range.

Leaflet 20-20 Thread Inserts

1 Introduction

This Leaflet gives guidance on the design, fitting and removal of thread inserts, which are frequently used in threaded attachment holes of airframe and engine components.

2 General

Thread inserts are usually fitted in light alloy materials such as aluminium, magnesium, bronze and brass, to provide a large diameter thread and thus a stronger attachment point for bolts or studs. In addition, thread inserts are often specified for repair work, where the original thread has been damaged and fitment of an insert enables the original size bolts to be used without affecting interchangeability.

- 2.1 There are basically two types of inserts available. One is known as a wire thread insert and is made from specially formed wire wound into a helical coil, and the other is known as a thin wall insert and is made from a tube with threads formed on both the inside and the outside surfaces. Both types are manufactured in a variety of materials and finishes and may have either plain or self-locking threads.
- 2.2 Thread inserts should only be used when specified in the relevant manual, drawing or repair scheme and care should be taken to ensure that the correct insert is used. Inserts should be installed strictly in accordance with the manufacturer's instructions, since there may be slight variations between inserts conforming to the same specifications.
- 2.3 Because of the basic differences between wire thread and thin wall inserts, these are dealt with separately in paragraphs 3 and 4 respectively.

3 Wire Thread Inserts

A wire thread insert (Figure 1) is a precision formed wire of diamond section (usually of spring steel or stainless steel) wound into a helical coil, the cross-section of the wire forming a thread both inside and outside the coil. When correctly installed, the coil provides a thread which conforms to a particular British Standard or other specification with a good surface finish and the inherent flexibility to compensate to some degree for any errors of form in the engaging bolt or screw. The radial pressure attained in fitting the insert produces good self-locking characteristics. The possibility of thread failure from vibration, fatigue, corrosion or seizure is also reduced. Wire thread inserts have a tang at the inner end to facilitate fitting with a special tool; this tang may be removed after installation if required.

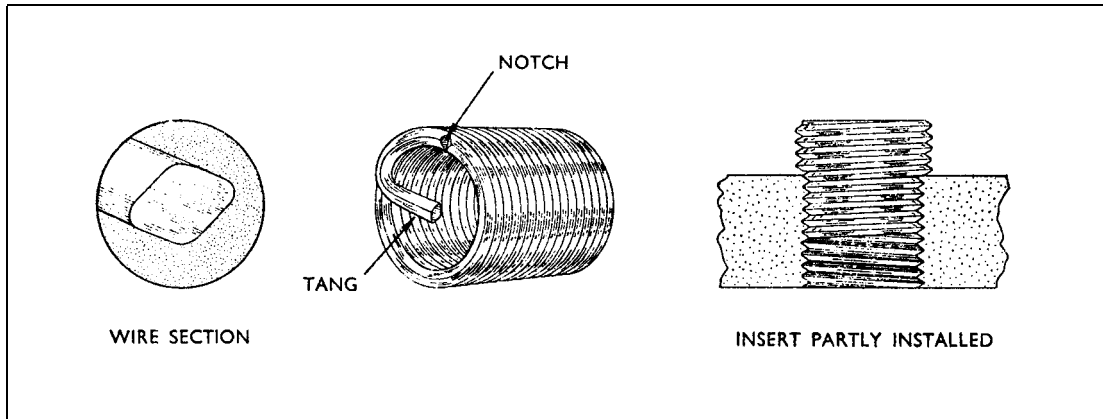

Figure 1 Typical Wire Thread Insert

3.1 Identification

Wire thread inserts manufactured in the UK generally conform to SBAC(AS) standards, those with BA, BSF and BSP threads being identified by having the tang painted yellow. This range of inserts is supplied in five standard lengths of approximately 1, 1½, 2, 2½ and 3 times the nominal thread diameter. Wire thread inserts manufactured to different standards are often identified in a different way, and reference should be made to the particular manufacturer's literature for details concerning identification.

- 3.1.1 In its free state an insert is shorter and has a larger diameter than when installed and since the Parts Lists refer to the installed dimensions, identification by measurement is not practical.

3.2 Installation

Since the internal and external threads on a thread insert have the same number of threads per inch and the internal thread is designed to be of standard size, then a special size tap is required to cut the threads into which the insert is fitted. These special taps and checking gauges are provided by the insert manufacturers. Installation procedures, which comprise drilling and tapping the hole, thread gauging, insertion of the insert and removal of the tang, are outlined in paragraphs 3.2.1 to 3.2.5.

3.2.1 Drilling

The hole for the insert should be drilled to the diameter and depth specified in tables supplied by the insert manufacturer, the depth being calculated from the fitted length of the insert, plus the thread runout, plus a half pitch gap at each end of the insert (see Figure 2). Care should be taken to ensure that the hole is drilled in the correct location and square to the surface, and that all swarf is removed before tapping. In some cases, particularly when the hole is near to the edge of the component, it may be necessary to check for cracks by a specified non-destructive testing method.

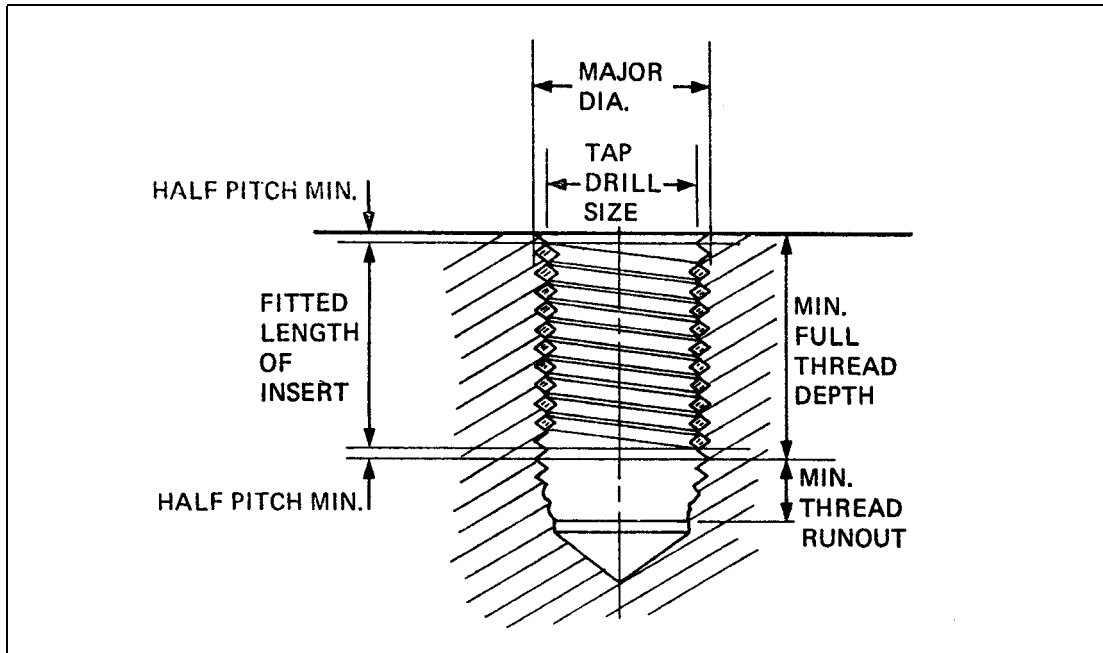

Figure 2 Wire Thread Insert Hole Data

3.2.2 Thread Tapping

The thread should be tapped with a special tap provided by the insert manufacturer, a straight-fluted tap being used for hand tapping and a spiral-fluted tap for machine tapping where this is possible. Normal workshop practices should be used for tapping, with special emphasis on cutting the thread coaxially with the hole. Lubricant should be used according to the type of metal being cut, e.g. a light mineral oil is generally recommended for tapping light alloys.

3.2.3 Thread Gauging

After the insert thread has been cut it should be cleaned of all swarf and foreign matter. The thread should then be checked with a special GO/NO GO plug gauge provided by the insert manufacturer to ensure that the thread is satisfactory. Any thread imperfections indicated by tightness of the GO gauge should be removed by further use of the original tap or, if this is ineffective, by use of a new tap.

3.2.4 Fitting the Insert

An insert should be screwed into the tapped hole by the use of either an inserting key or an inserting tool of the prewind type (see Figure 3), depending upon which is recommended for the particular insert. A different sized key or tool is provided for each size of insert.

- a) The inserting key should be used by sliding the insert onto it so that the tang is engaged in the driving slot at its forward end; the assembly should then be applied to the tapped hole, compressing the insert downwards with the thumb and forefinger of one hand while turning the key with the other hand; no downward pressure should be applied on the key. The insert will find into the thread and should be installed so that the outer end of the insert is at least half a pitch below the surface of the component.

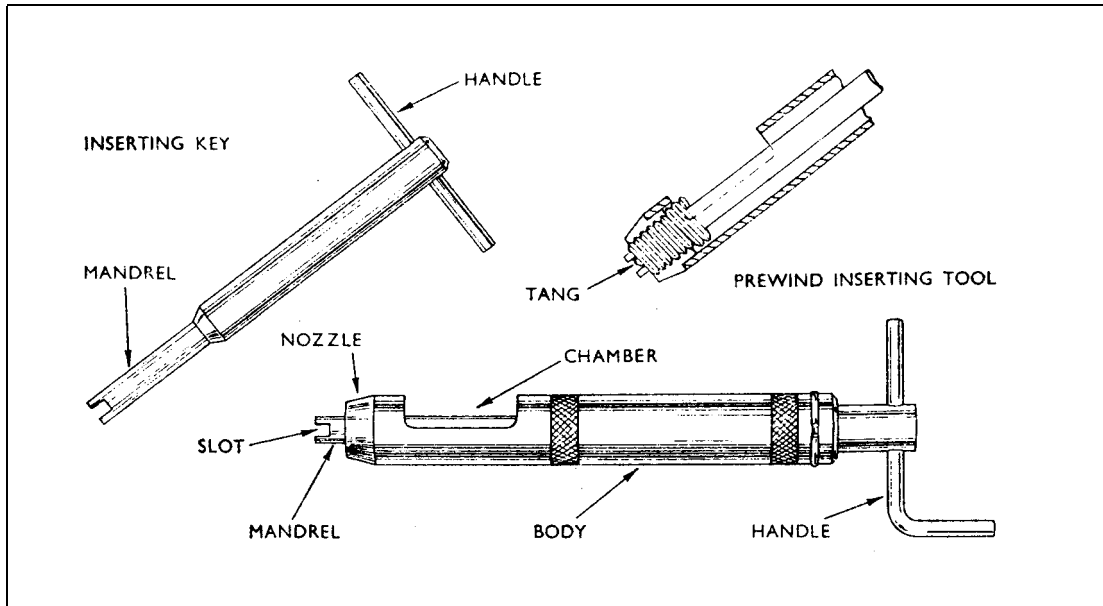

Figure 3 Inserting Key and Prewind Inserting Tool

- b) When a prewind tool is used the insert should be placed in the chamber with the tang towards the nozzle and the mandrel pushed forward through the insert to engage the tang in the slot. The mandrel should be rotated clockwise and pushed gently forward to engage the insert coil in the nozzle threads, rotation being continued until the insert is about to emerge from the outer end of the nozzle. The tool should then be placed squarely over the tapped hole and the handle rotated to transfer the insert from the tool into the tapped hole; no forward pressure should be used.
- c) Unless otherwise stated, inserts should be installed so that the outer coil is at least half a pitch below the component surface.
- d) Absolute cleanliness of the tapped hole and freedom from burrs is essential to prevent distortion of an insert. When jointing compound or anti-corrosive compounds are specified, they should be applied strictly according to the relevant instructions and surplus compound should be removed as specified after installing the insert.

3.2.5 Removal of the Tang

It is not always necessary to remove the tang of a wire thread insert, but removal may be specified in some cases for screw clearance or product appearance, both in blind holes and through holes. A tang in a through hole is removed by use of the inserting key used as a punch, with the tang outside the engaging slot, or by use of a special punch (Figure 4). A sharp blow with a hammer on the key or punch will fracture the wire at the notch where the tang joins the coil. To remove the tang from an insert fitted in a blind hole, long round-nosed pliers are required; the tang should be bent backwards and forwards through the insert bore until it fractures at the notch and can be removed.

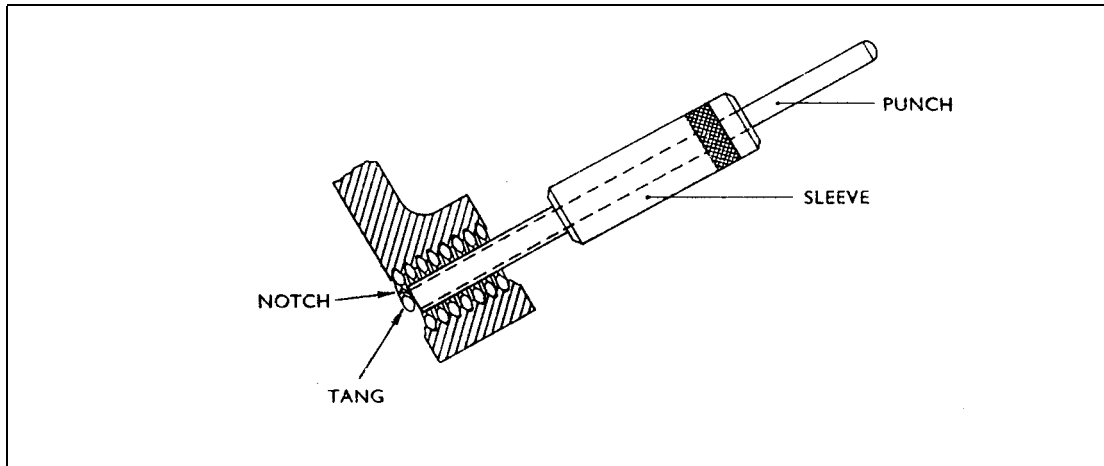

Figure 4 Tang Break-off Punch

3.3 Removal of Inserts

Under normal circumstances, particularly when fitting instructions have been carefully carried out, the removal of inserts should be unnecessary. However, if an insert has to be removed because of bad fitting, damage or wear, this can be done by bending the top coil inwards to form a rough tang and unscrewing the insert with the insertion tool or a pair of pliers. Some manufacturers recommend the use of a tapered left-hand tap of appropriate size, which grips the top coils internally and unwinds the insert when rotated. Other manufacturers provide a range of extractor tools which are fitted with hardened and tempered blades (Figure 5); the blade will bite into the inner surface of the insert, which can then be unscrewed. After removal of an insert, the threads in the hole should be carefully examined for damage before fitting a new insert.

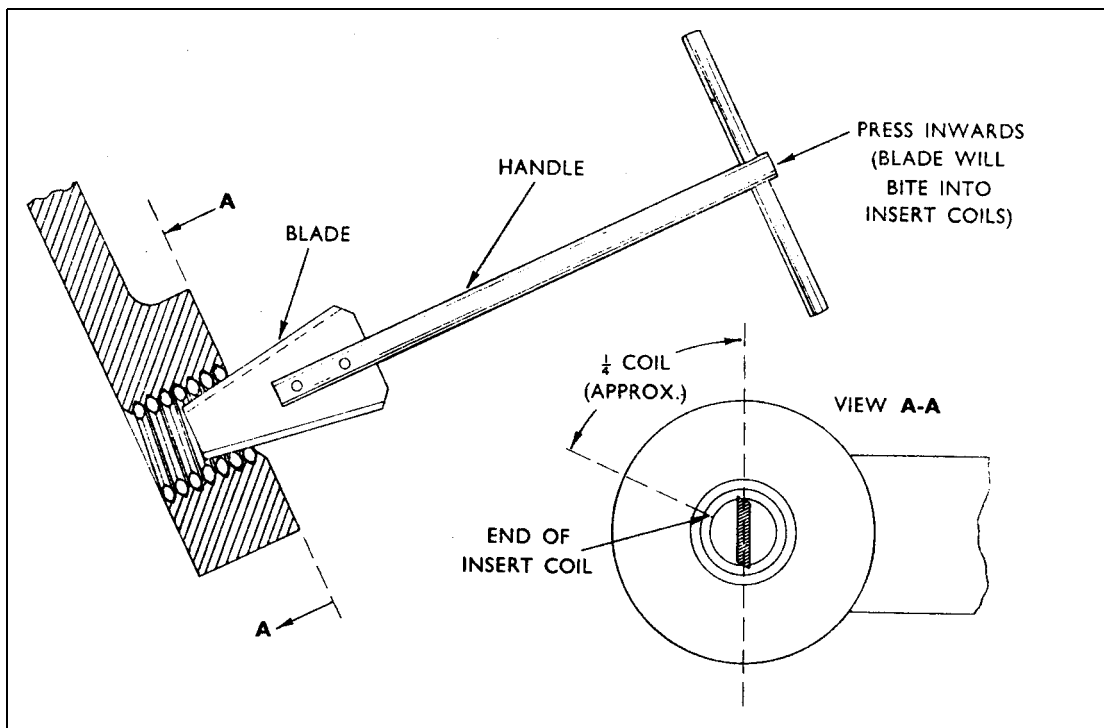

Figure 5 Typical Extractor Tool

4 Thin Wall Inserts

A thin wall insert (Figure 6), comprises a tube with threads formed on its internal and external surfaces. These inserts do not exert any outward radial pressure on the threaded holes into which they fit, and are locked in position by driving a number of pre-assembled keys into slots round the outer surface of the insert, by swaging a knurled outer portion into a counterbore, or by fitting a separate serrated locking ring after the insert is installed. Inserts are supplied in a variety of types, materials and finishes, and the internal thread may be non-locking, or self-locking by means of a deformed thread or nylon insert; inserts are identified and ordered by manufacturer's part numbers.

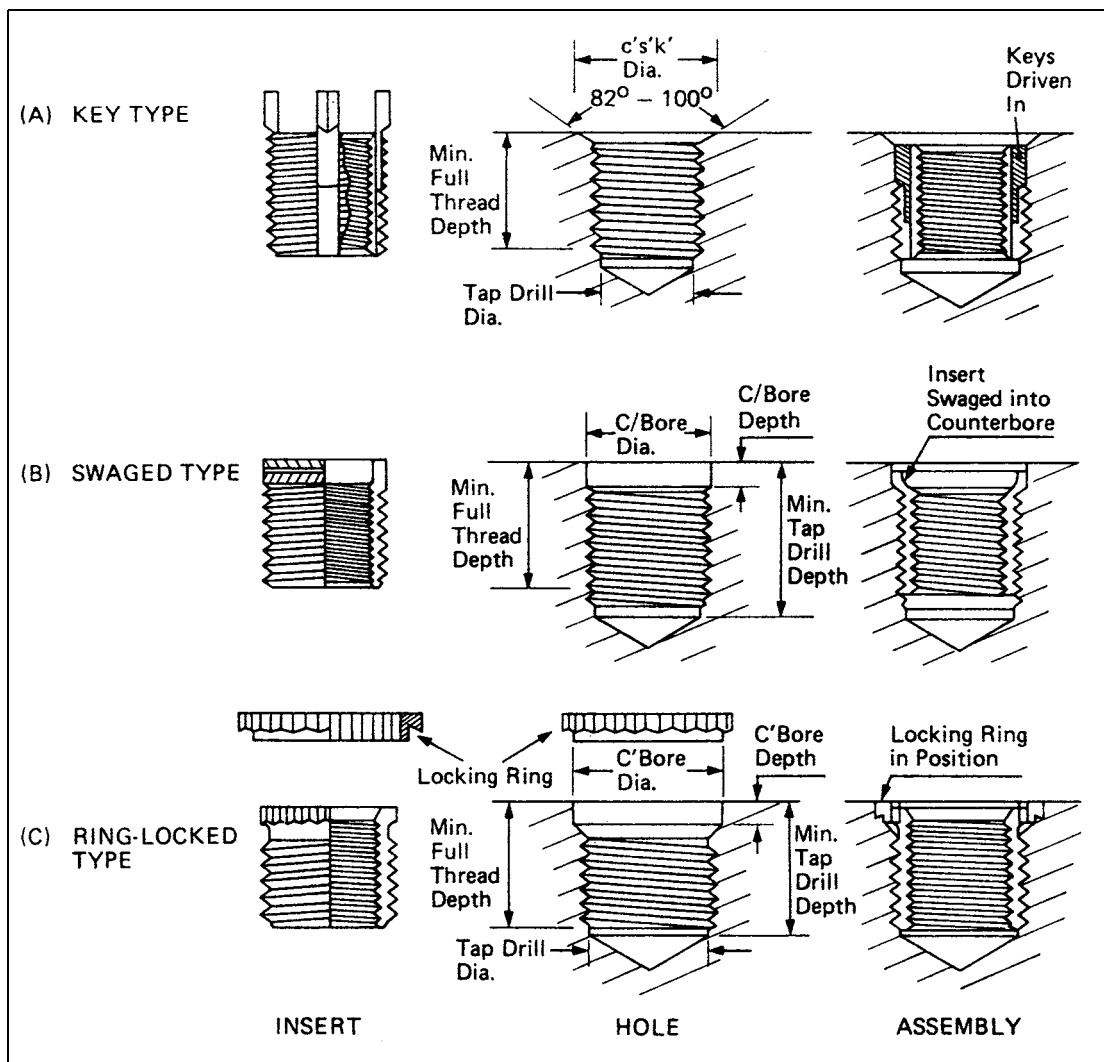

Figure 6 Thin Wall Inserts

4.1 Key-locked Inserts

4.1.1 Drilling and Tapping

Tables provided by the manufacturer give details of the drill diameters, hole depths and taps to be used to form the threaded holes for each size of insert; with key-locked inserts the outer edges of the holes should also be countersunk to a specified depth. When preparing the threaded holes, the general precautions outlined in paragraph 3.2.1 and 3.2.2 should be carefully followed.

4.1.2 Installation

The inserts may be screwed in by hand or by the use of an installation tool (Figure 7), until the keys butt against the component surface, this being the correct installed depth. The keys are then driven into place by hammer blows or a press, using the installation tool as a punch. When the keys are flush with the top of the insert, installation is complete.

4.1.3 Removal

Should it become necessary to remove a key-locked insert, this may be done as follows:

- a) Drill out the insert to a diameter equal to the distance between two opposing key slots and to the depth of the key heads.
- b) Deflect the keys inward with a punch and break them off.
- c) Remove the insert with a standard extractor.
- d) After removal of the insert, the threads on the part should be inspected for damage. If the threads are undamaged a replacement insert of the same size may be fitted, but care should be taken to ensure that the keys are located in different places from the original keys.

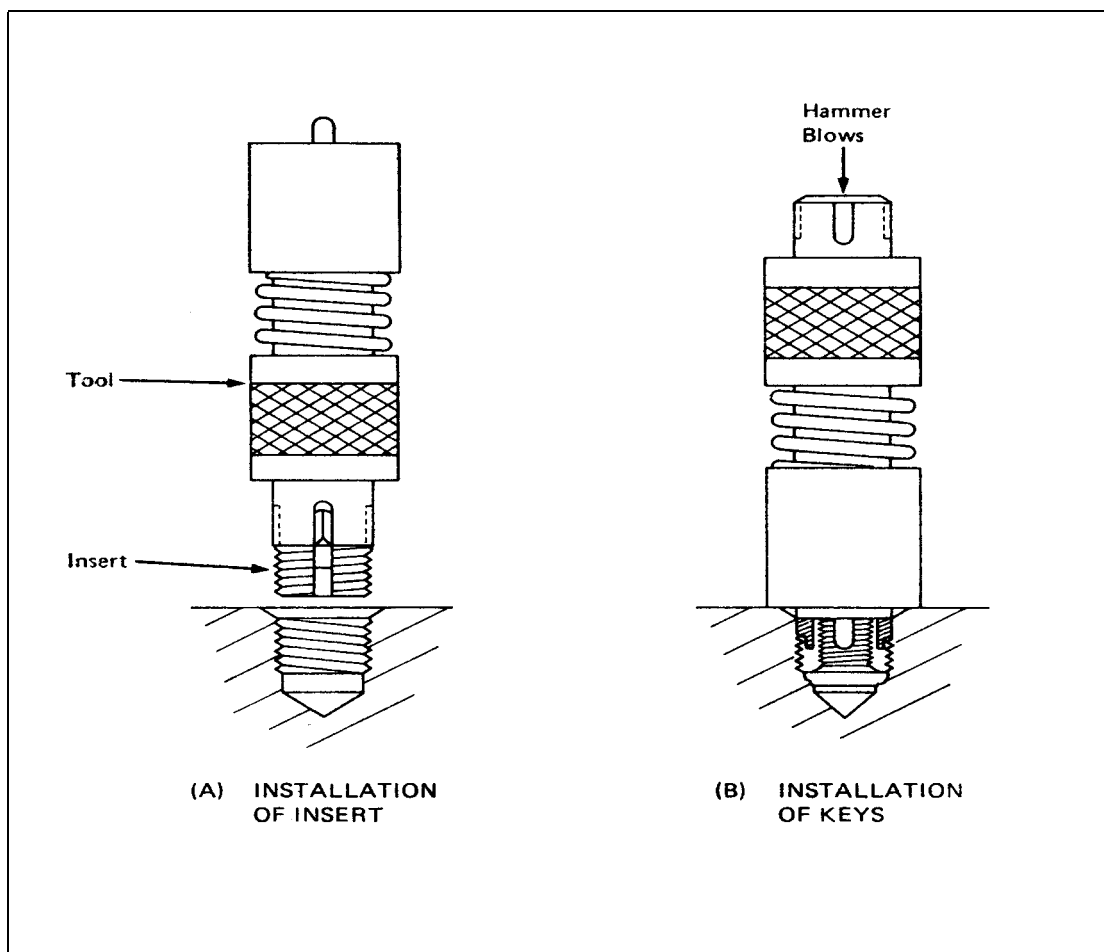

Figure 7 Installation Tool (Key-locked Inserts)

4.2 Swaged Inserts

4.2.1 Drilling and Tapping

The holes for these inserts must be drilled with a special drill and counterboring tool supplied by the insert manufacturer for each size of insert. Holes should be drilled so that the counterbore depth is as specified in the relevant tables for the insert concerned, and the precautions outlined in paragraph 3.2.1 should be observed. The hole should be tapped using a tap of the relevant size, to the drawing requirements. All swarf should then be removed and the thread inspected.

NOTE: The drill/counterboring tool has a drill portion of sufficient length to permit regrinding a number of times before the minimum drilling depth is reached. It is important to check the length of the drill portion when drilling blind holes, to prevent breaking through the lower surface.

4.2.2 Installation

A special insertion tool is used for installing these inserts (Figure 8). The insert internal thread is deformed in such a way as to permit the insertion of the hexagonal driver (unified threads), or has three axial grooves (metric threads), so that the insert can be rotated. The insert should be screwed into the threaded hole until it is the specified distance below the component surface. The insert is swaged by hammer blows on the end of the tool and installation is complete when the stop washer face contacts the component surface.

NOTE: Insertion tools for the larger sizes of inserts are power operated.

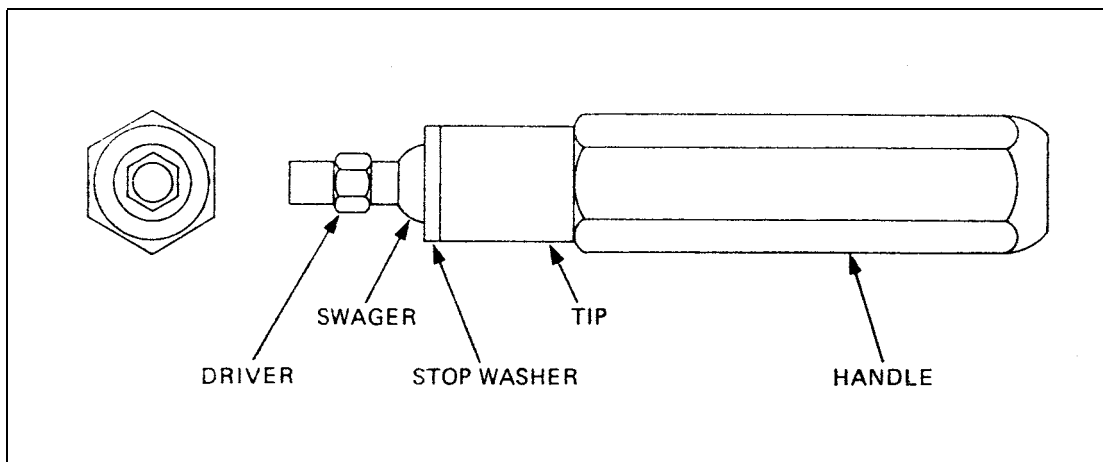

Figure 8 Typical Insertion Tool (Swaged Inserts)

4.2.3 Removal

Where necessary, swaged inserts may be removed in the following way:

- Using a drill of the relevant diameter, drill the insert to the depth specified in the manufacturer's tables to separate the swaged portion of the insert.
- Carefully remove the swaged portion with a scribe or similar tool.
- Using the installation tool, unscrew and remove the threaded part of the insert.
- The thread and counterbore should be checked for size and damage. If satisfactory, a replacement insert of the same size may be fitted.

4.3 Ring-locked Inserts

4.3.1 Drilling and Tapping

The holes for these inserts should be drilled and counterbored in a similar way to those for swaged inserts. Similar drilling/counterboring tools should be used and the dimensions of the holes should conform to those listed in the tables provided by the manufacturer; the precautions outlined in paragraph 3.2.1 should also be observed. The holes should be tapped using a tap of the specified size, to drawing requirements. All swarf should then be removed and the thread should be inspected.

4.3.2 Installation

A special tool is used to install these inserts (Figure 9), the bore having serrations which fit the serrations of one particular size of insert. The insert should be screwed into the prepared hole until its upper surface is 0.25 to 0.5 mm (0.010 to 0.020 in) below the component surface. The locking ring should then be placed over the insert, so that the inner serrations engage those of the insert. Installation is completed by fitting the drive tool (Figure 9) into the locking ring (ensuring that it is square to the component surface), and hammering the end of the tool so that the outer serrations on the locking ring bite into the material surrounding the counterbore. The installed locking ring should be flush with the surface of the component.

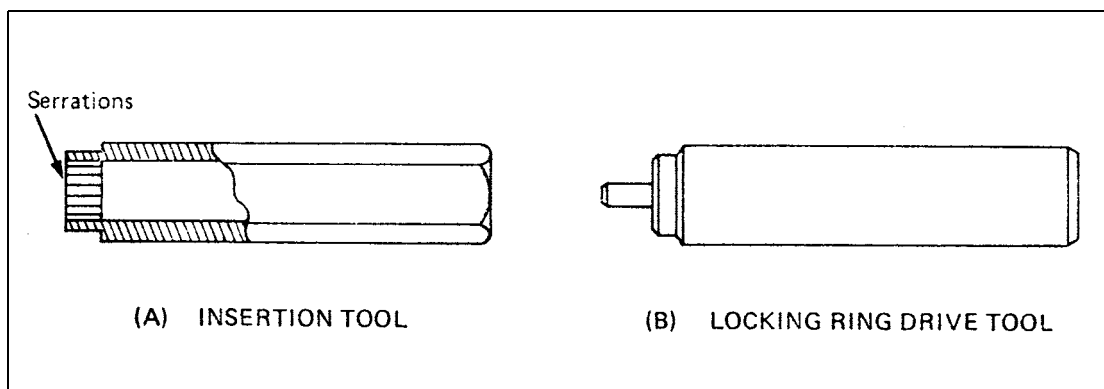

Figure 9 Tools For Ring-locked Inserts

4.3.3 Removal

When necessary, ring-locked inserts may be removed in the following way:

- Drill out the insert to the depth of the counterbore, using a drill of the diameter specified in the tables provided by the manufacturer.
- Remove the insert by use of a standard stud extractor or a left-hand threaded tap of suitable size.
- If necessary, use a punch to separate and remove the remaining portion of the locking ring.
- Provided the hole thread is not damaged, a replacement insert and locking ring of the same size may be fitted.

INTENTIONALLY LEFT BLANK

Leaflet 20-30 Cable – Splicing and Swaging

1 Introduction

- 1.1 This Leaflet provides guidance and advice on the recommended procedures for splicing and swaging the cable used in aircraft control systems. The methods by which completed cable assemblies may be identified are described in Leaflet E-10.
- 1.2 To obviate the need for the revision of this Leaflet when new issues of specifications referred to are published, the prefix or suffix indicating the issue number of the specification has been omitted.

2 Cable

- 2.1 The cable used in British aircraft control systems is preformed, and complies with British Standards (BS) Specifications W9, W11, W12 or W13, or with American Specification MIL-W-83420 (formerly MIL-W-1511 and MIL-L-5424). Preforming is a process in which each individual strand is formed into the shape it will take up in the completed cable. This makes the cable more flexible, easier to splice and more resistant to kinking. Preformed cable will not unravel; also, if a wire in a preformed cable should break, the broken wire will lie flat, and, therefore, be less likely to prevent the cable from passing round pulleys and through fairleads.
- 2.2 The manufacture of a cable is determined by the number of strands it contains and by the number of individual wires in each strand. For example, a cable designated 7 x 19, consists of 7 strands, each strand containing 19 wires. Wires are wound round a king wire in one or two layers. Strands are generally wound round a core strand in one layer, the direction of winding being stipulated in the relevant specification. The two most common forms of manufacture are illustrated in Figure 1 and the manufacture of the various sizes of cable is included in Tables 1 and 2.

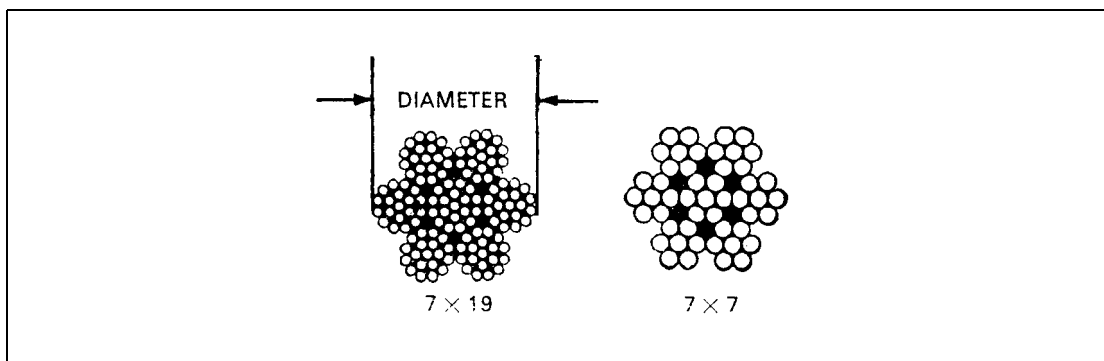

Figure 1 Steel Wire Cable

- 2.3 Preformed cable is manufactured from either galvanised carbon steel (BS W9 and W12 and American Standard MIL-W-83420, Composition A) or corrosion resisting steel (BS W11 and W13, and American Standard MIL-W-83420, Composition B) and is impregnated with friction preventive lubricant during manufacture. The American specification also provides for a range of nylon-covered cable. Non-preformed single strand cable may be found on some aircraft, but will normally only be used for relatively unimportant systems. Tables 1 and 2 list the more common sizes of cable according to the method of classification.

Table 1 Cable Classified By Breaking Load In Hundredweights

Minimum breaking load (cwtf)	Manufacture	Maximum diameter of cable (in)	
		BS W9	BS W11
3	4 x 7	0.065	0.065
5	7 x 7	0.08	0.08
10	7 x 14	0.12	0.12
15	7 x 19	0.15	0.15
20	7 x 19	0.16	0.16
25	7 x 19	0.18	0.18
30	7 x 19	–	0.21
35	7 x 19	0.21	–
40	7 x 19	–	0.24
45	7 x 19	0.24	–
55	7 x 19	–	0.27
60	7 x 19	0.27	–

Table 2 Cable Classified By Nominal Diameter

Nominal diameter of cable		Manufacture	Minimum breaking load ¹		
			Carbon steel	CR steel	
(in)	(mm)		MIL-W-83420 type A and BS W12 (lbf)	MIL-W-83420 type B (lbf)	BS W13 (kN)
1/16	1.6	7 x 7 ²	480	480	2.15
3/32	2.4	7 x 7 ³	920	920	4.10
1/8	3.2	7 x 19	2000	1760	7.85
5/32	4.0	7 x 19	2800	2400	10.70
3/16	4.8	7 x 19	4200	3700	16.50
7/32	5.6	7 x 19	5600	5000	22.25
1/4	6.4	7 x 19	7000	6400	28.40

1. The breaking loads listed are those quoted in the current issues of the specifications. 1 lbf = 4.448 N.

2. 1/16 in and 3/32 in cable to specification MIL-W-83420 may also be of 7 x 19 manufacture.

3. 2.4 mm cable to BS W13 may also be of 7 x 19 manufacture.

3 Handling of Cable

Cable may be permanently damaged, or its working life may be considerably curtailed, by careless handling and unwinding. Care is necessary to prevent the cable from forming itself into a loop, which, if pulled tight, could produce a kink. A kink is shown by the core strand leaving the centre of the rope and lying between the outer strands or protruding in the form of a small loop.

3.1 Cable should always be stored on suitably designed reels. The diameter of the reel barrel should be at least forty times the cable diameter. British Standards stipulate that reels should be made from a wood which will not corrode the cable and that interior surfaces should be lined with an inert waterproof material. Precautions should also be taken to protect the cable from grit and moisture and from damage in transit.

3.2 To remove cable from a reel, a spindle should be placed through the centre of the reel and supported in a suitable stand. Cable may then be removed by pulling the free end

in line with the reel, allowing the reel to rotate. Cable should not be unwound by paying off loose coils, or by pulling the cable away from a stationary reel laid on its side.

- 3.3 When a long length of cable has been cut from a reel and it is necessary to coil the cut piece, the coil diameter should be at least 50 times the cable diameter, with a minimum diameter of 150 mm (6 in). Care must be taken to prevent dust, grit and moisture, from coming into contact with the coiled cable.
- 3.4 The ends of stored cable are whipped to prevent fraying and if a length has been cut from the reel, the remaining free end should be whipped.
- 3.5 When a coil is being unwound, the coil should be rotated so that the cable is paid out in a straight line.

3.6 **Cutting Cable**

Cable should always be cut using mechanical methods. Cable cutters or heavy duty pliers should normally be used, alternatively, the cable may be laid on an anvil and cut with a sharp chisel and hammer blows. Cable should not be cut by flame. If a non-preformed cable is being cut, it should be whipped with waxed cord on both sides of the cut, prior to being cut. With a preformed cable it will normally only be necessary to bind the cable temporarily with masking tape.

4 **Swaging**

Swaging is an operation in which a metallic end fitting is secured to the end of a cable by plastic deformation of the hollow shank of the end fitting. The end of the cable is inserted into the hollow shank of the fitting and the shank is then squeezed in a swaging machine, so that it grips the cable. This is the most satisfactory method of attaching an end fitting to a cable and it can be expected to provide a cable assembly at least as strong as the cable itself. Most transport aircraft and a large number of light aircraft, use control cables manufactured in this way.

- 4.1 Manufacturers of cable assemblies normally swage with rotary machines. In these machines the shank of the end fitting is placed between suitable dies and is subjected to a series of forming blows, which reduce the shank diameter and lock the fitting to the cable.
- 4.2 Swaging may also be carried out on a portable swaging machine, which squeezes the shank of the end fitting between dies. The use of a portable swaging machine is discussed in paragraph 5.
- 4.3 A range of swaged end fittings is covered by BS specifications, but some older types of aircraft may be fitted with cable assemblies containing components complying with SBAC AS specifications which are not obsolete. When it is necessary to make up control cables for these aircraft, approval may be granted for the use of equivalent BS parts, but the complete cable control run may have to be changed.
- 4.4 BS specifications provide a range of fittings which prevent incorrect assembly of control cables. Turnbarrels and tension rods are designed to connect to screwed end and tapped end swaged fittings respectively. For each size of cable two alternative sizes of end fittings are available and each size is provided with either a left or right hand thread. Swaged fittings can thus be arranged to ensure that a control run cannot be incorrectly assembled.

5 Portable Swaging Machines

Although unserviceable cables are usually replaced by cables which have been manufactured, pre-stretched and proof loaded in accordance with an approved drawing which have been supplied by the aircraft manufacturer, occasions may arise when such a cable is not available and it is necessary to make up a cable assembly locally. Provided that the process is permitted and that the appropriate drawings or instructions are available, end fittings may be swaged onto a cable using a hand-operated machine such as the one illustrated in Figure 2.

NOTE: The proficiency of a person engaged in the manufacture of locally made cable assemblies, should be established by trial swagings on test cables, which should be tested to the satisfaction of the supervising inspector. The effectiveness of subsequent swaging operations should be checked periodically, by selecting a representative sample and subjecting it to a tensile test to destruction.

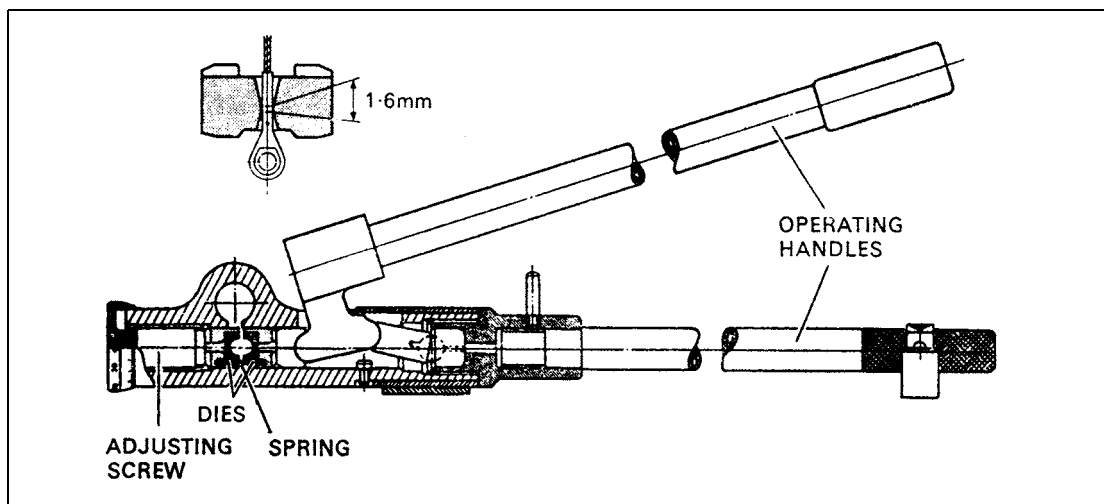

Figure 2 Portable Swaging Machine

5.1 A portable swaging machine is supplied with sets of dies for swaging various types of fittings to cables of appropriate size and with gauges for checking shank diameter after swaging. The swaging machine is normally mounted on a wooden block and should be used on a low bench so that adequate pressure can be applied to the lever. An adjusting screw in the head of the machine alters the amount of squeeze applied and a graduated scale permits accurate setting.

5.2 Swaging Procedure

The procedure outlined below is applicable when a machine of the type illustrated in Figure 2 is used. Where use of a different type of machine is authorised, the procedure is similar, except for the setting and operation of the machine, which in all cases should be in accordance with the manufacturer's instructions.

- a) Ensure that the new cable is the correct size, by using a suitable gauge, or by measuring the diameter as indicated in Figure 1.
- b) Cut the cable to the length specified on the drawing (see paragraph 3.6) and ensure that the ends are clean and square.

NOTE: Swaging elongates the end fitting and an allowance for this must be made when cutting the cable. The allowance to be made should be stated on the appropriate drawing or specification.

- c) Select the appropriate end fitting and clean it by immersing it in solvent; then shake and wipe dry.
- d) Assemble the end fitting to drawing requirements. With drilled-through fittings, the cable end must pass the inspection hole, but be clear of the locking wire hole. For fittings with a blind hole, the cable must bottom in the hole. Bottoming may be checked by marking the cable with paint, at a distance from the end equal to the depth of the hole and ensuring that the paint mark reaches the fitting when the cable is inserted. When the cable and the fitting are correctly assembled, they should both be lightly lubricated.
- e) Fit the dies for the particular end fitting in the swaging machine, open the handles of the machine and unscrew the adjuster until the end fitting can be placed in the dies. With the end fitting centred in the die recess, close the handles fully and screw in the adjuster until the dies grip the fitting. Open the handles and tighten the adjuster by the amount of squeeze required for the particular end fitting; normally this should be approximately 0.18 mm (0.007 in).
- f) Place the fitting in the position shown in the small sketch in Figure 2, so as to swage to within approximately 1.2 mm (0.050 in) from the inspection hole. Check that the cable is in the correct position (see d)) and operate the handles to squeeze the fitting.
- g) Release the handles and rotate the fitting through approximately 50°. Repeat the squeezing and rotating until the fitting has been moved one full turn.
- h) Withdraw the end fitting from the dies 1.6 mm (0.0625 in) and repeat the cycle of squeezing and turning.
- i) Continue operation until the whole shank is swaged. Check the diameter of the shank and if it has not been reduced to the size required by the appropriate drawing or specification, re-set the adjusting screw and repeat the swaging operation.
- j) When the shank of the end fitting has been reduced to the correct diameter, remove and inspect the fitting (see paragraph 5.3).
- k) Fit the identification device as prescribed in the drawing and mark it with the cable part number in the prescribed manner (in some cases the part number may be etched directly onto the end fitting). The identification may be in the form of a wired-on tag, as illustrated in Leaflet E-10, or a cylindrical sleeve lightly swaged onto the shank of the end fitting.
- l) Assemble any fittings, such as cable stops, on the cable and swage on the opposite end fitting.
- m) Dip the end fittings in lanolin, to prevent corrosion resulting from damaged plating and to exclude moisture.

5.3 Inspection of Swaged Fittings

On completion of the swaging operations, the following inspection should be carried out.

- a) Check that the correct combination of cable and fittings has been used.
- b) Re-check the diameter of the swaged shank, using a GO-NOT GO gauge or a micrometer. If the diameter of the fitting is too small, it has been over-swaged and as such the cable and the fitting must be rejected. Excessive work hardening of the fitting will cause it to crack and may also damage the cable.
- c) Check, by means of the inspection hole or paint mark, that the cable is correctly engaged in the end fitting (see paragraph 5.2 d)).

- d) Check that the swaging operation has not disturbed the lay of the cable, where the cable enters the end fitting.
- e) Ensure that the shank is smooth, parallel and in line with the head of the fitting and that the swaged shank length is correct.
- f) Proof load the completed cable assembly in accordance with the appropriate drawing (see also paragraph 8).
- g) Inspect the fittings for cracks using a lens of 10 x magnification, or carry out a crack detection test, using magnetic or dye processes, as appropriate.
- h) Check that the cable assembly is the correct length (see paragraph 8.7) and ensure that any required identification marking, including evidence of proof loading, has been carried out and that any specified protective treatment has been applied.

NOTE: The first swaged fitting in a production batch is usually sectioned after proof loading, so that the interior surface can be examined for cracks. If this check is satisfactory, the settings on the swaging machine should be noted and used for completion of the batch.

6 Swaged Splices

A number of proprietary methods are used to secure cable in the form of a loop, which may then be used to attach the cable to a terminal fitting or turnbuckle. The 'Talurit' swaged splice is approved for use on some British aircraft control cables and is also widely used on ground equipment. The process provides a cable assembly which, when used with cable to BS W9 and W11, has a strength equal to approximately 90% of the breaking strength of the cable. It may only be used to replace cables employing the same type of splice, or hand splices and must not be used where swaged end fittings were used previously.

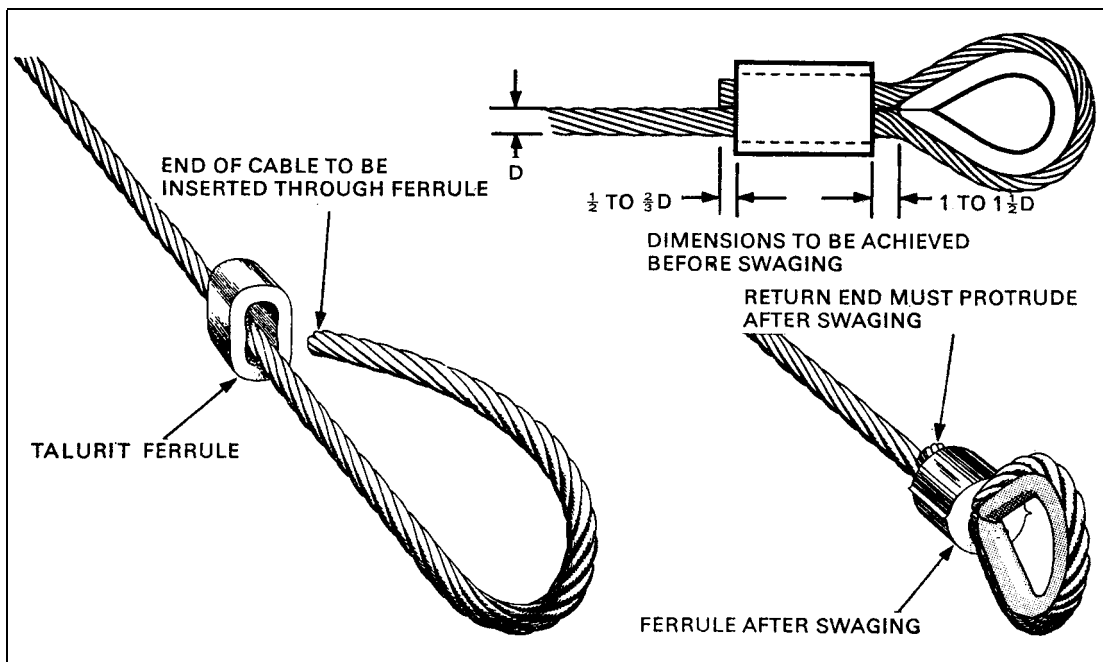

Figure 3 'Talurit' Swaged Splice

- 6.1 A typical 'Talurit' splice is illustrated in Figure 3. To make this type of splice, the end of the cable is threaded through a ferrule of the appropriate size, looped and passed

back through the ferrule. A thimble is fitted in the loop and the ferrule is squeezed between swages (dies) in a hand-operated or power-operated press. The metal of the ferrule is extruded between the two parallel lengths of cable and around the cable strands firmly locking the cable without disturbing its lay.

- 6.2 Ferrules are made in a variety of shapes, sizes and materials. Aluminium alloy ferrules are used with galvanised or tinned carbon steel cable and copper ferrules are used with corrosion resisting steel cable.
- 6.3 When making a splice, the proper ferrule should be selected by the code numbers indicated on the appropriate drawing and the associated swages should be fitted to the press. The loop and thimble should be adjusted after the swages have closed sufficiently to grip the ferrule. The cable must grip the thimble firmly and the dimensions indicated in Figure 3 must be obtained before swaging commences.
- 6.4 The press should be operated until the faces of the swages are touching, then the pressure should be released. Continuing to apply pressure after the faces have met, may cause damage to the press and swages. Only one pressing operation is normally required, but some long ferrules are designed for swaging in two separate operations, the swages in these cases being half the length of the ferrule.
- 6.5 After swaging, surplus metal is visible as a flash along each side of the ferrule, this may be removed with a file. If no flash has been formed, the sizes of the ferrule and swages should be re-checked and it should be ascertained that the press is operating correctly.
- 6.6 The inspection of the finished splice consists of ensuring that the ferrule is correctly formed and not cracked carrying out a proof test, as described in paragraph 8. In some instances a dimensional check is also specified, but, since the swages meet during the pressing operation, little variation in diameter will normally be obtained.

7 Manual Splicing

Although manual splicing may be permitted for some particular applications, it is seldom used on modern aircraft. It is less strong than either the swaged fitting or the swaged splice and considerable experience is required in order to consistently obtain splices of adequate strength by this method. Persons engaged on splicing should be given an initial competency test and representative samples of their work should be selected periodically, for tensile tests. Splices on cable manufactured to BS W9 or W11, should not fail at less than 80% of the breaking strength of the cable. There are several methods of splicing, the procedure in each case varying in detail. A recommended method is given in the following paragraphs, but other methods may be used, provided that the resulting splice is no less strong.

7.1 Splicing Procedure

The cable is normally spliced around a brass or steel thimble. The identification tag and where applicable, the turnbuckle eye-end, should be placed on the thimble and the centre of the thimble bound to the cable. The cable should be whipped with waxed thread on either side of the thimble, as shown in Figure 5.

NOTE: When cutting the cable to length, approximately 23 cm (9 in) should be allowed for each splice on cable up to 3.2 mm (1/8 in) diameter and 30 cm (12 in) should be allowed for each splice in cable between 4.0 mm (5/32 in) and 6.4 mm (3/4 in) diameter.

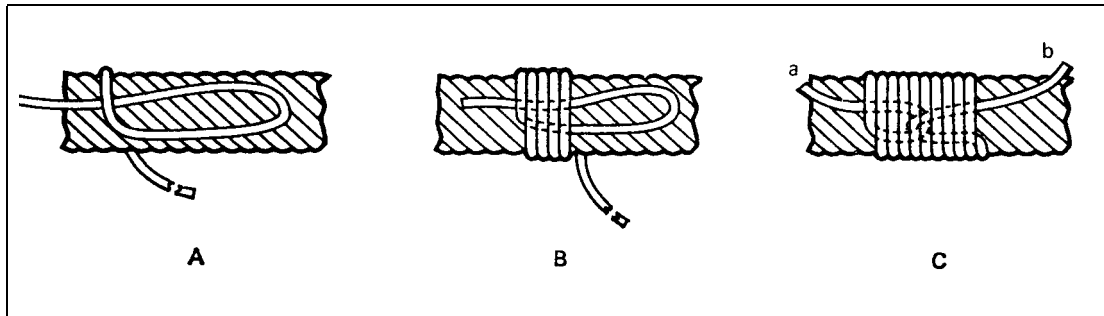

Figure 4 Method of Whipping

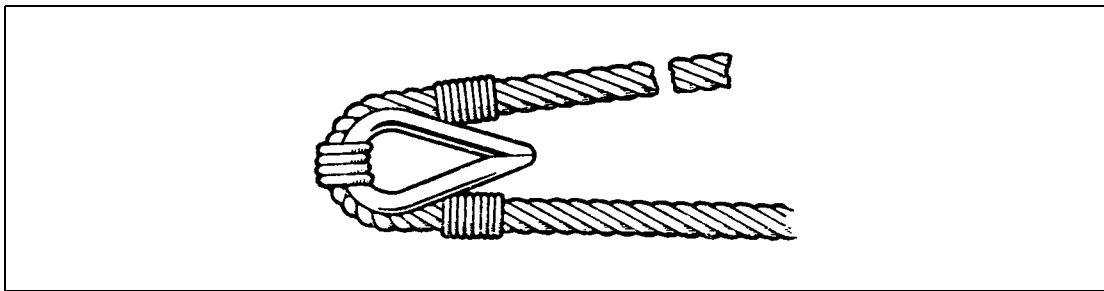

Figure 5 Whipping of Cable

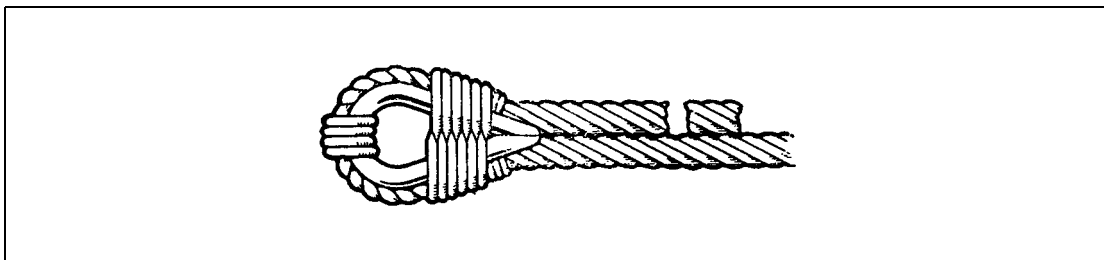

Figure 6 Figure of Eight Binding

- 7.1.1 The method of whipping with a waxed thread is illustrated in Figure 4. A loop is formed in the thread (sketch A) and binding commenced from the open end of the loop towards the closed end (sketch B). When a sufficient length has been whipped, end 'b' of the thread is passed through the loop and secured under the whipping by pulling end 'a' (sketch C); the loose ends are then cut off.
- 7.1.2 It is essential that the cable and thimble are securely held in a vice, using cable clamps or specially prepared vice blocks and bound with a figure of eight binding as illustrated in Figure 6. No attempt should be made to splice a cable without fully effective clamping devices.
- 7.1.3 The strands at the end of the cable should be separated and whipped or soldered to prevent unlaying of single wires. The cable is then ready for splicing.

NOTE: For descriptive purposes, the six outer strands of the free end of the cable will, in paragraphs 7.1.4 to 7.1.9, be called the 'free strands' and will be numbered 1 to 6, while the outer strands of the main cable will be lettered 'a' to 'f', as shown in Figures 7 and 8.

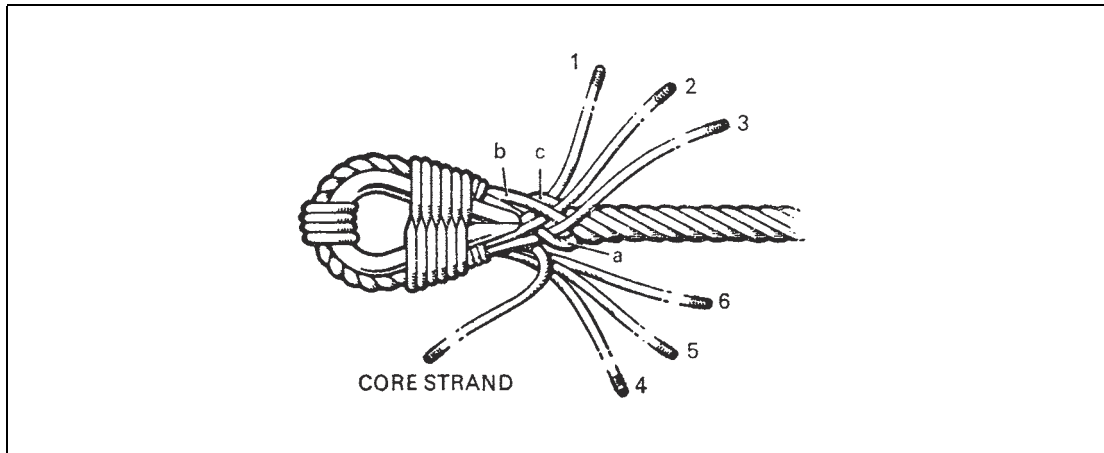

Figure 7 First Round of Tucks (Front)

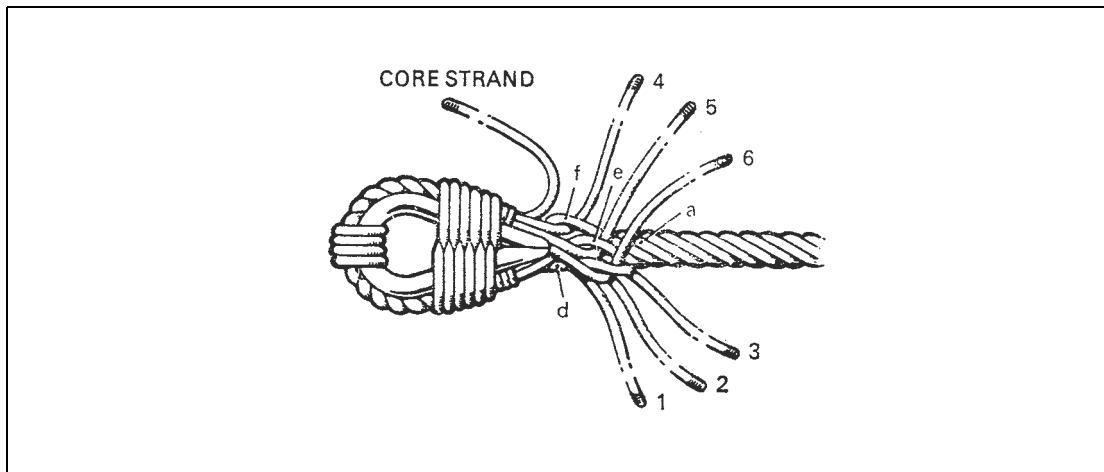

Figure 8 First Round of Tucks (Reverse)

- 7.1.4 The core strand should be positioned so that there are three free strands on either side and it should be bent back slightly (see Figure 7).
- 7.1.5 The first round of tucks should be completed as follows – 3 under a, 1 under b and c, 2 under b (see Figure 7); turn over and tuck 4 under f, 5 under e and 6 under d (see Figure 8). All free strands should be pulled tight and then bent back to lock them in position. Care should be taken to avoid disturbing the lay of the cable by excessive pulling.
- 7.1.6 The core strand should be taken forward and temporarily secured to the main cable with thread, then pulled under a suitable free strand into the centre of the splice. The six free strands should then, in turn, be tucked over a strand and under a strand, e.g. 3 over b and under c, 1 over d and under e. On completing the second round of tucks, the free strands should be pulled tight and locked back as before.
- 7.1.7 The third round of tucks should be completed in a similar manner to the second, taking care to bury the core strand in the centre of the splice.
- 7.1.8 The last full round of tucks, i.e. the fourth, should be the same as the second and third rounds.
- 7.1.9 The half round of tucks for finishing the splice should be completed by tucking alternate free strands over one and under two main cable strands. To finish and shape

the splice, it should be beaten with a hardwood or rawhide mallet on a hardwood block, while the cable is held taut. The splice should be rotated against the direction of tucking during the beating process. Excessive hammering must be avoided. Free strands should be cut off flush with the splice and the last one and a half tucks should be whipped with waxed cord. The central binding and figure of eight lashing should be removed.

- 7.1.10 If both ends of the cable are to be spliced, the cable length should be checked before commencing the second splice, so that the completed cable will be of the required length.

7.2 Inspection of Splice

- 7.2.1 The splice should be inspected for symmetry and appearance. The wires should be close together and no light should show between the strands or wires. A typical splice is shown in Figure 9.

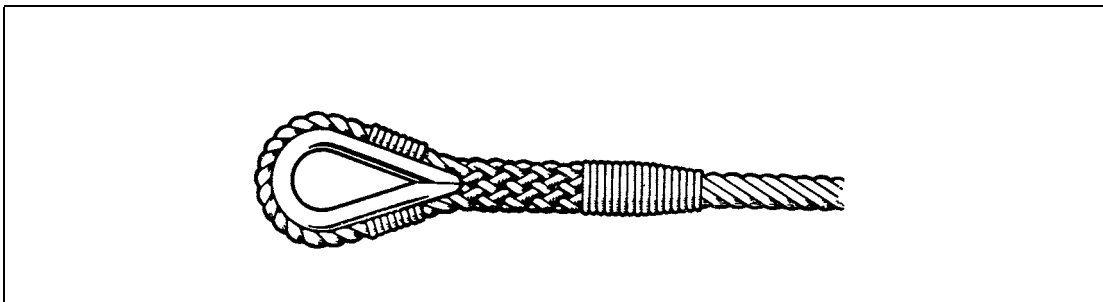

Figure 9 Typical Spliced Joint

- 7.2.2 The resistance of the splice to bending should be checked. A bad splice will not be resistant to bending and when it is bent, the strands and wires will slacken.
- 7.2.3 The tightness of the thimble in the loop should be checked. The lay of the strands in the cable should be maintained as far as the splice permits, as disturbance in the lay of the cable adjacent to the splice may result in considerable weakening of the cable.
- 7.2.4 The completed cable must be proof loaded in accordance with paragraph 8.

8 Proof Loading

- 8.1 All cables must be proof loaded after swaging or splicing, by subjecting the cable to a specified load. The purpose of proof loadings is both to ensure that the end fittings are satisfactorily installed, and to pre-stretch the cable, i.e. to bed-in the strands and wires. British practice is to load the cable to 50% of its declared minimum breaking strength. American practice is to load the cable to 60% of its declared minimum breaking strength. If no specific instructions are included in the drawing, then loading of the cable should be carried out in accordance with whichever of these practices is appropriate.
- 8.2 If end fittings have been fitted or splices have been made on pre-stretched cable, no appreciable elongation will result from proof loading. If the cable was not pre-stretched, it may be expected to elongate slightly and this should have been taken into consideration on the appropriate drawing.
- 8.3 A test rig suitable for proof loading cables is illustrated in Figure 10, but other similar methods would be acceptable. The cable should be contained within a trough or other protective structure, to safeguard the operator in the event of failure of the cable.

Adaptors should be used to attach the cable end fittings to the test rig and these should be at least as strong as the cable. Particular care should be taken not to damage the thimbles on spliced cables; packing or bushes should be used to spread the load.

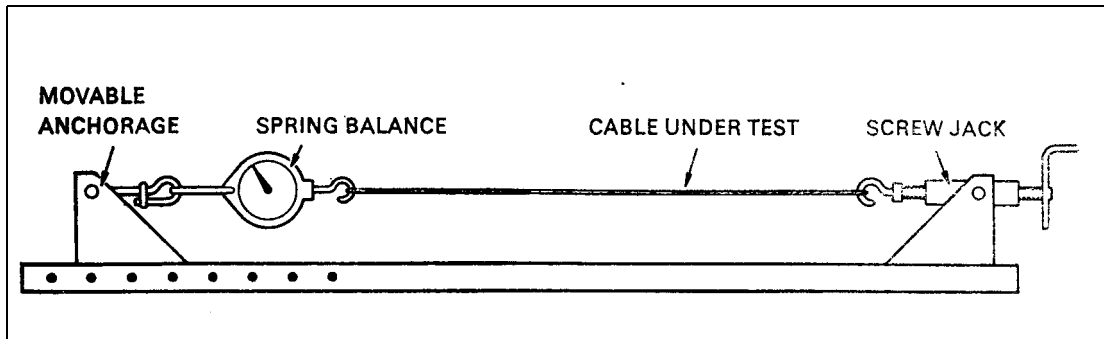

Figure 10 Test Rig for Proof Loading

- 8.4 Before proof loading a cable with swaged end fittings, the cable should be painted with a quick-drying paint at its point of entry into the fittings and allowed to dry. Cracking of the dried paint during proof loading will indicate slipping of the cable resulting from an unsatisfactory joint.

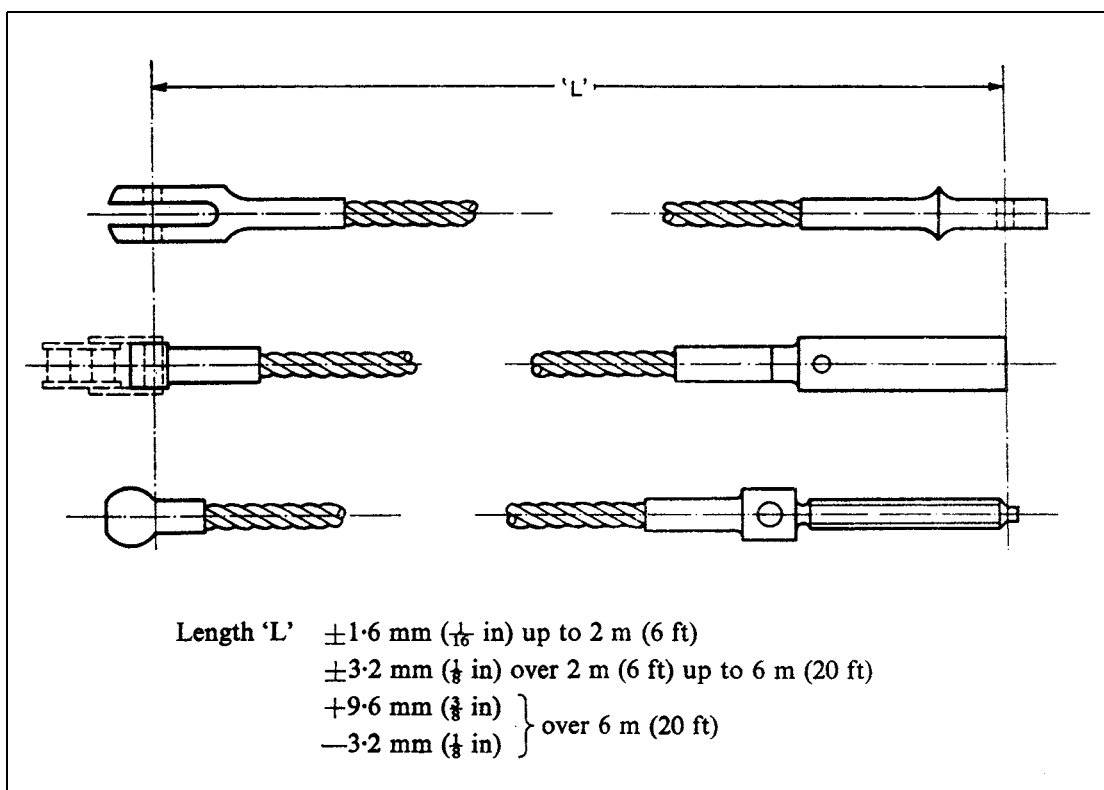

Figure 11 Length of Assemblies

- 8.5 The test should consist of slowly applying the specified load, maintaining this load for a minimum specified period (normally 30 seconds for swaged fittings, but up to 3 minutes for splices), then releasing it and carefully examining the cable for signs of pulling out of the end fittings, or stretching of the splice.

- 8.6 The end fittings should be checked for cracks using an electro-magnetic method (Leaflet F-50) or, if the fitting is of stainless steel, a penetrant dye process (Leaflet F-20).
- 8.7 The length of the completed cable assembly should be measured after proof loading. Prior to measurement, cables longer than 120 cm (4 ft) should be tensioned with a load of approximately 550 N (112 lbf), or 2% of the breaking load of the cable, whichever is the least. Figure 11 shows the datum points and tolerances for the measurement of cables fitted with swaged end fittings to British Standards. Cables with different types of end fittings, or loops, should be measured according to the appropriate drawings or specifications.

Leaflet 20-40 Control Chains, Chain Wheels and Pulleys

1 Introduction

- 1.1 The purpose of this Leaflet is to provide guidance and advice on the installation and maintenance of steel roller chains (including 'O' ring chains), chain wheels and pulleys used in aircraft control systems. The information can be used to support that published by the type certificate holder or equivalent. The details are written addressing UK-designed aircraft but the principles can be read across to other states of design.
- 1.2 Chains provide strong, flexible and positive connections and are generally used wherever it becomes necessary to change the direction of control runs in systems where considerable force is exerted, e.g. aileron and elevator controls. The change of direction is achieved by the use of chain wheels or pulleys. Chains may be found in, control column installations, aileron controls and elevator controls and in trim control systems.
- 1.3 Chains may be used solely in control runs or in conjunction with cable assemblies. In either case, the incorrect assembly of the chains should be rendered impossible by the use of non-reversible chains in conjunction with the appropriate types of wheels, guards and connectors.
- 1.4 Subject headings are as follows:

Paragraph	Subject	Page
1	Introduction	1
2	Specifications	1
3	Chain Assemblies	2
4	Installation of Chain Assemblies	4
5	Maintenance Inspection	6
6	Inspection of Chain Assemblies	7
7	Installation of Chain Wheels and Pulleys	8

2 Specifications

- 2.1 Chains used for aircraft purposes are generally of the simple roller type and comply with the requirements of British Standard BS 228: 1984, entitled Specification for Short Pitch Transmission Precision Roller Chains and Chain Wheels. A complete schedule of dimensions and breaking loads for chains is given in this Standard.
- NOTES: 1)** BS 228:1994 was equivalent to ISO 606:1994, and the official number given to the BSI adoption was 'BS 228:1994, ISO 606:1994'. This was withdrawn in 2006 and there is no official replacement.
- 2)** ISO replaced ISO 606:1994 with the current ISO 606:2004. BSI did not adopt the 2004 version, however, and there is no current BSI adoption of ISO 606.
- 2.2 Chain assemblies are produced to standards prepared by the Society of British Aircraft Constructors (SBAC). These standards provide a range of chains built up in

various combinations with standard fittings, e.g. end connectors with internal or external threads, bi-planer blocks for changing the plane of articulation of a chain through 90° (see Figure 4) and cable spools for connecting chains to cables having eye-splices. Such fittings are illustrated in Figures 1 and 4.

3 Chain Assemblies

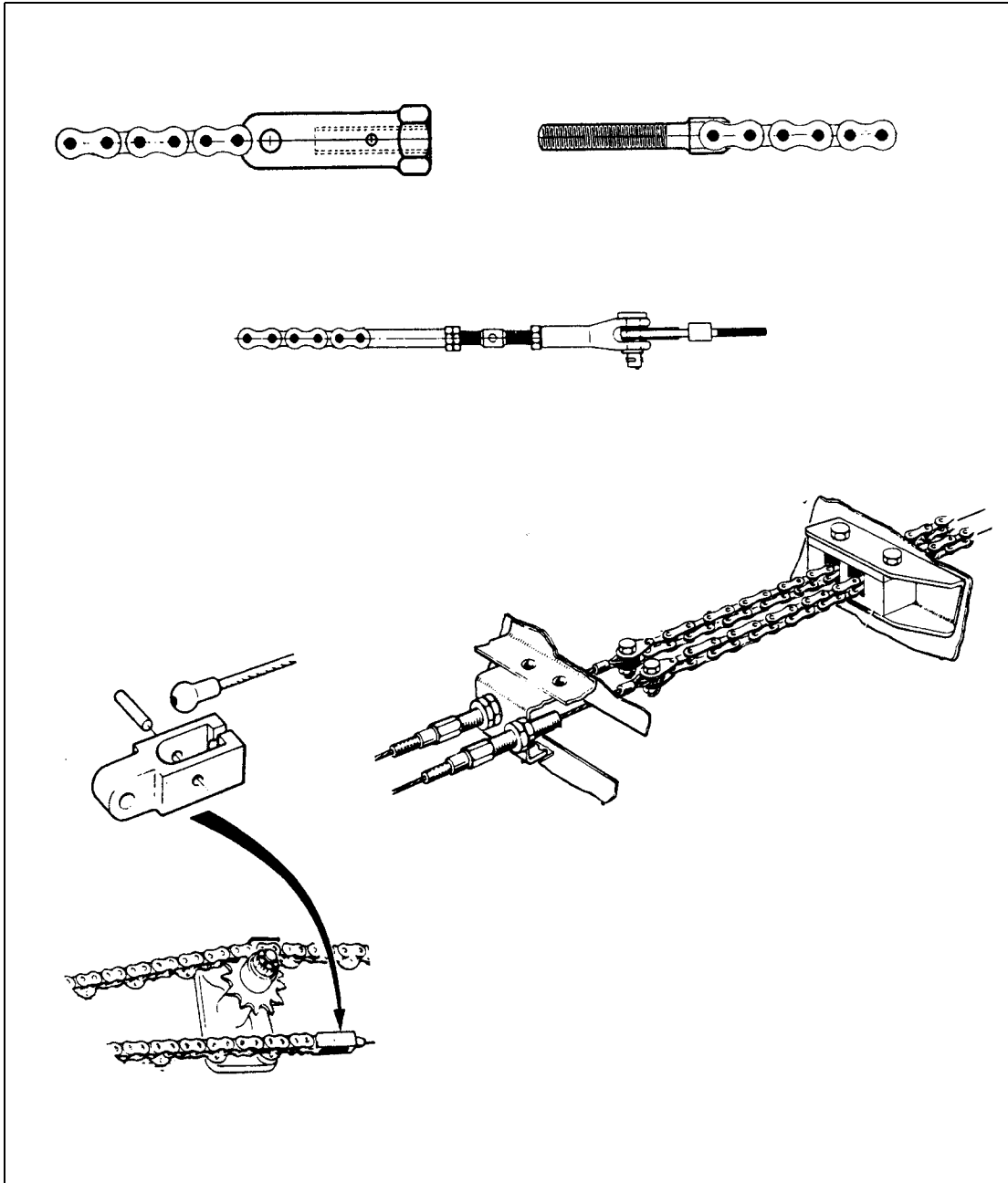

Figure 1 Standard Chain Fittings

- 3.1 A simple roller chain consists of outer and inner plates, rollers, bearing pins and bushes; the component parts are shown in Figure 2(a). The chain has three principal dimensions (known as gearing dimensions since they are related to the size of the wheels on which the chains run), these being pitch, width between inner plates and roller diameter. The positions at which these dimensions are measured are shown in Figure 2(b).

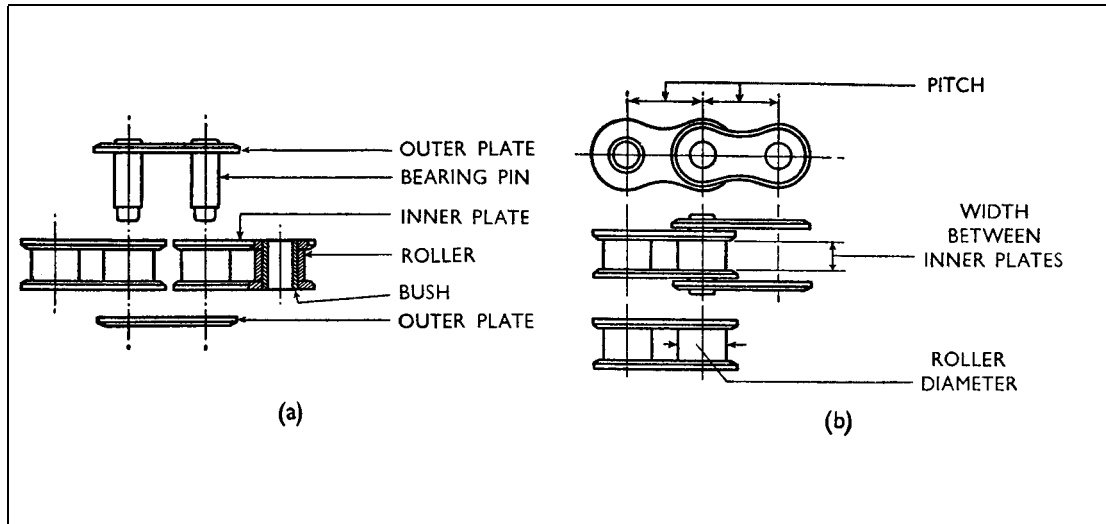

Figure 2 Chain Details

3.2 A typical assembly for $\frac{3}{8}$ in and $\frac{1}{2}$ in chains, using a standard end connector with an internal thread, is shown in Figure 3.

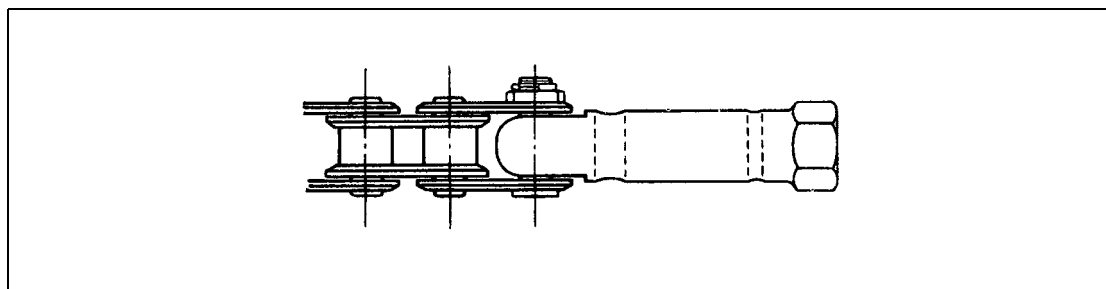

Figure 3 Typical Chain End Assembly

3.3 The pitch of the chain is the distance between the centres of the rollers and for aircraft purposes, four sizes of chain are standardised by the SBAC, as shown in Table 1. The proof load for a chain meeting BS 228/1506C should be one-third of the minimum breaking load. The relevant figures for simple chains are given in Table 1.

Table 1

Chain Pitch	BS No.	Minimum Breaking Load	Proof Load (lb)
8 mm	1	800 lb	267
0.375 in	2	1900 lb	634
0.50 in	4	1800 lb	600
0.50 in	6	3500 lb	1166

NOTE: Historic source reference: BS 228.

- 3.4 Chain assemblies for aircraft systems should be obtained as complete, proof-loaded units from approved chain assembly manufacturers and no attempt should be made to break and reassemble riveted links or riveted attachments. If it is necessary to disconnect the chain, this should be undertaken only at the bolted or screwed attachments. Split pins must not be re-used and this applies also to nuts and bolts which have been peened.

NOTE: The procedure specified by SBAC standards for securing nut and bolt joints for Class 1 application is to peen the bolt end for 8 mm pitch chain and to split pin the bolts of the remaining standard chains. In all cases the nut is actually a lock nut, since the hole in the loose outer plate is also tapped.

- 3.5 The use of cranked links for the attachment of the chain to end fittings, etc, is not permitted, thus, when a chain is required to terminate in a similar manner at each end, the length should be an odd number of pitches. For the same reason, an endless chain should have an even number of pitches.
- 3.6 The use of spring clip connecting links is prohibited and the attachment of chains to other parts of the system should be effected by positive methods such as pre-riveted or bolted joints.

3.7 **The 'O' Ring Chain**

3.7.1 **Description**

The 'O' ring chain is a development from the automotive industry that has extended chain life considerably over comparable traditional roller chains. Outwardly, 'O' ring chains are similar to a standard roller chain but with the addition of 'O' ring seals between the inner and outer plates. This development provides each link with its own sealed environment and therefore the ingress of dirt or other contaminants is effectively prohibited.

'O' ring chains may also be known as 'X' ring chains or by other names due to the design of the link seals, but for all intents and purposes they can be considered the same.

3.7.2 **Performances Differences from Standard Roller Chains**

An 'O' ring chain is initially inherently stiffer in operation than a standard roller chain. This should be considered for use in low power environments. Lubrication may still be required (sparingly) on the chain and sprocket interface although an 'O' ring chain can run dry at low speeds.

'O' ring chains are pre-stretched and do not exhibit any tangible signs of chain wear throughout their working lives. This trait also helps with sprocket life. Once fitted, removal is not generally considered for the life of the chain. Wear out is normally detectable but brown dust (rusting wear products) is caused by eventual lubrication failure. If this condition is detected on any part of the chain, the chain is considered to be non serviceable and should be changed immediately.

Traditional chain care procedures are not generally required with an 'O' ring chain.

4 **Installation of Chain Assemblies**

- 4.1 Figure 4 illustrates typical arrangements of chain assemblies. Figure 4(a) shows the simple transfer of straight-line to rotary motion, Figure 4(b) illustrates how a change of direction of straight-line motion is obtained, whilst Figure 4(c) shows a change of direction of motion in two planes by the use of a bi-planer block.

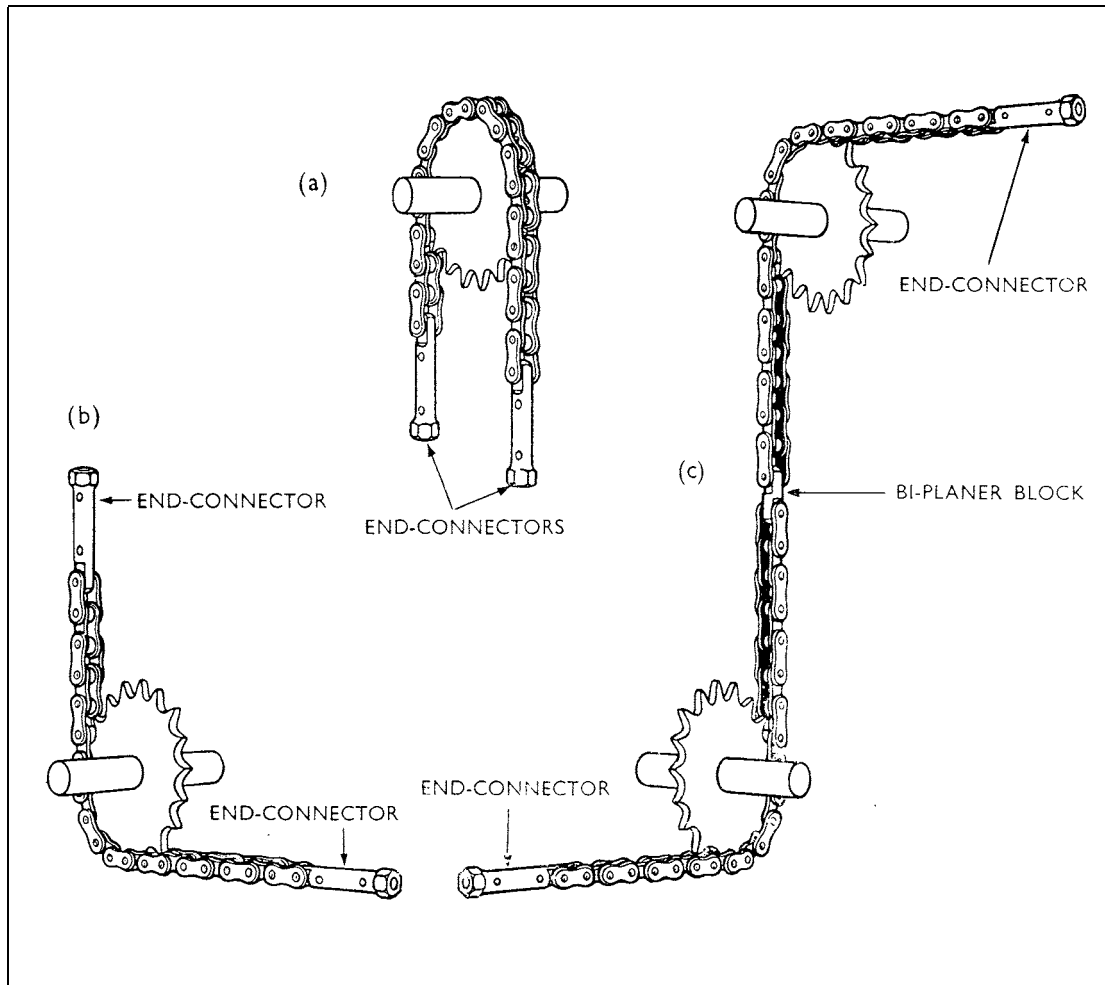

Figure 4 Typical Chain Assembly Arrangements

4.2 A range of non-interchangeable end fittings is available as a safeguard against the crossing of controls. However, these connectors do not always prevent the possibility of reversing the chain end to end on its wheel, neither do they prevent the possibility of the chain being assembled to gear on the wrong face where two wheels are operated by the same chain. Such contingencies can be overcome by the use of non-reversible chains.

4.3 **Non-reversible Chains**

4.3.1 Non-reversible chains are similar to standard chains except that every second outer plate is extended in one direction in order to break up the symmetry of the chain. The complete system of non-reversibility involves the use of five features, i.e. the non-reversible chain, the shroud on the wheel, correct positioning of the wheel on its shaft, the chain guard and non-interchangeable connectors. The shape of the special outer plates and the principle of non-reversible chains is shown in Figure 5.

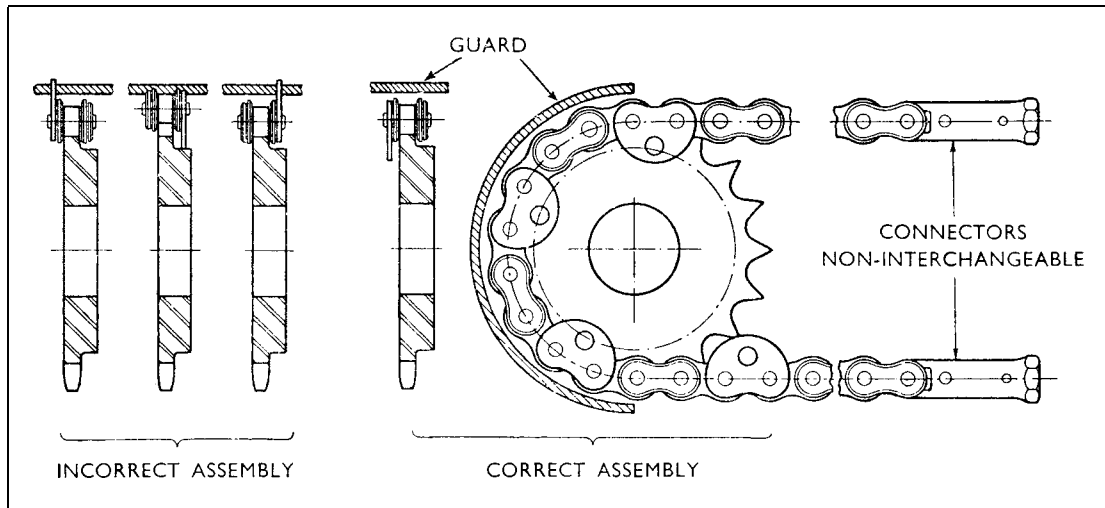

Figure 5 Non-reversible Chain Assembly

4.3.2 It will be seen from Figure 5 that by providing a shroud on one side of the wheel and by making use of the chain guard, the reversing of the chain end to end on its wheel is not possible. It should be borne in mind that in practice a special feature, such as an attachment collar, a key, or a flat on the shaft in conjunction with a specially shaped hole, is incorporated in the wheel mounting to ensure that it can be assembled on its shaft in one definite position only.

4.3.3 Figure 6 illustrates an instance where the use of jockeys is necessary or where contra-rotation of the wheels is required; it will be seen that the feature of non-reversibility does not affect the ability of the chain to gear on both sides.

4.4 Inspection after Assembly

4.4.1 After installation in the aircraft, the chain should be examined for freedom from twist, particularly in instances where the attachment is made to threaded rods by means of screwed end connectors, or where a twist may inadvertently be applied to the chain during the locking of the assembly. Care should be also taken to ensure that the chain is not pulled out of line by the chain wheel; the chain should engage smoothly and evenly with the wheel teeth and there should be no tendency for the chain to ride up the teeth.

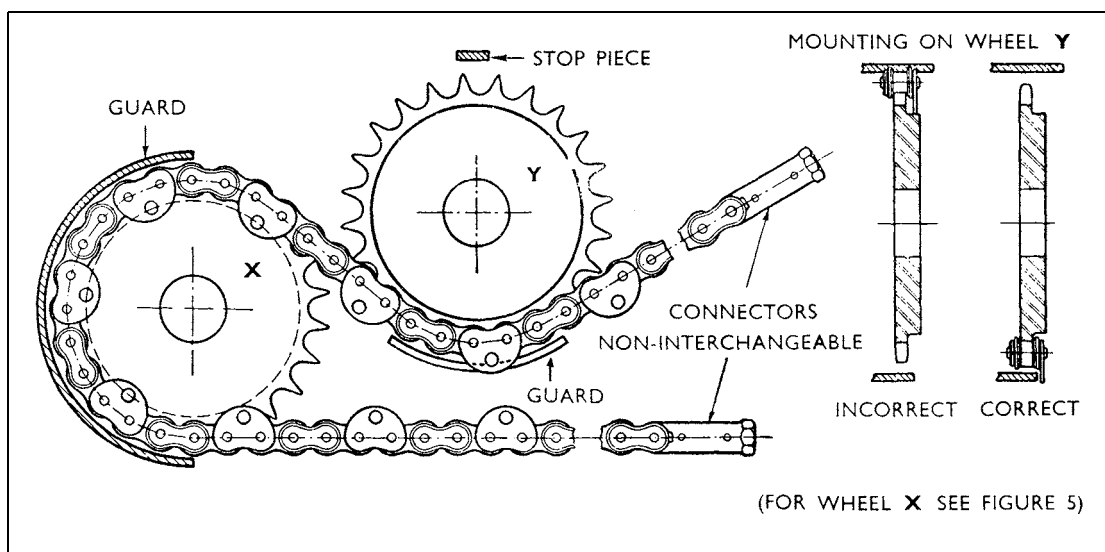

Figure 6 Non-reversible Chain With Jockey Pulley

- 4.4.2 The pre-tensioning of chains should not be excessive, as this will cause friction, but should be just sufficient to prevent any back-lash in the system.
- 4.4.3 The guarding should be checked to ensure that jamming could not occur and that the chain would not come off the wheel should it become slack.
- 4.4.4 The security of end connections should be checked, care being taken to ensure that the split pins in the chain connecting bolts are correctly locked.
- 4.4.5 The initial lubricant on new chains should not be removed and the chains should be further lubricated after assembly by brushing all over, particularly on link edges, with lubricant complying with specification DTD 417B (now obsolescent), unless otherwise specified.

A range of commercially available high performance aerosol chain lubricants is available. Check individual brands for compatibility with 'O' ring chains.

NOTE: Obsolescent indicates that the standard will no longer be updated but will be retained to provide for the servicing of existing equipment.

- 4.4.6 The wheel or pulley mountings should be examined to ensure that the wheels or pulleys are firmly secured to the shafts or spindles, that they are correctly located and are running freely.

5 Maintenance Inspection

- 5.1 Chain assemblies should be inspected for serviceability at the periods specified in the relevant Maintenance Schedule; guidance on the recommended methods of checking chains is given in the following paragraphs.
- 5.2 The continued smoothness of operation between the chain and the chain wheel or pulley should be checked. If the chain does not pass freely round the wheel or pulley, it should be removed and checked as detailed in paragraph 6.
- 5.3 The chain should be checked for wear; if it is worn so that the links are loose and can be lifted away from the wheel teeth, it should be removed and checked for excessive elongation as detailed in paragraph 6.3.
- 5.4 The chain should be checked for damage, cleanliness, adequacy of lubrication and freedom from corrosion. If the inspection shows the chain to be corroded or otherwise defective, it should be removed.
- 5.5 In instances where it becomes necessary to adjust the tension of the chain in systems incorporating turnbuckles or screwed end connectors, care should be taken to ensure that the chain itself is not twisted during the adjustment. The connectors should be held firmly while the locknuts are being slackened or tightened.

6 Inspection of Chain Assemblies

6.1 General

Chain assemblies should be removed from the aircraft for complete inspection at the periods specified in the appropriate Maintenance Schedule.

6.2 Removal

When it is necessary to disconnect the chains the assemblies must be removed at design breakdown points.

6.3 Checking Elongation

6.3.1 If elongation through wear is suspected, the following procedure should be adopted:

- a) The chains should be cleaned by immersion in clean paraffin and brushing with a stiff brush; after cleaning, the chains should be dried immediately by hot air to ensure that no paraffin remains, otherwise the chains will corrode. The chains should be measured when clean but before any oil is applied.
- b) The chains should be placed on a flat surface and stretched by the application of a tensile load. Table 2 indicates the load applicable to the various sizes of chains. The length should then be measured between the centres of the bearing pins, elongation being calculated by the formula given in sub-paragraph c).

Table 2

Chain Pitch	BS No.	Tensile Load (lb)
8 mm	1	12
0.375 in	2	16
0.50 in	4	28
0.50 in	6	28

- c) The percentage extension over the nominal length should be calculated by the following formula:

$$\text{Percentage extension} = \frac{M - (X \times P)}{X \times P} \times 100$$

where

M = Measured length under load in inches.

X = Number of pitches measured.

P = Pitch of chain in inches.

6.3.2 If the extension is in excess of 2% on any section of the chain the whole run of chain should be replaced. Should localised wear be likely to occur in a chain run, additional checks should be made on such sections and the percentage extension ascertained from the formula given in paragraph 6.3.1 c). If the extension in such sections is in excess of 2%, the chain should be rejected.

6.3.3 The chain should be checked for kinks and twists by suspending it freely and sighting along the length; if kinks or twists exist the chain should be rejected.

6.4 Checking Articulation

The chain should be checked for tight joints by articulating each link through approximately 180°. The most suitable method being to draw the chain over a finger. Tight joints may be caused by foreign matter on the bearing pins or between the inner and outer plates; this may be remedied by cleaning as described in paragraph 6.3.1 a). If cleaning is not successful, the end of the bearing pin may be very gently tapped with a light hammer, but if this does not clear the joint, the chain should be rejected. Tightness may also be caused through lack of clearance between the inner and outer plates due to damage; if this is so, the chain should be rejected.

6.5 **Checking for Deterioration**

The chain should be examined for damage, cracks and wear to plates and rollers and for evidence of corrosion and pitting.

NOTE: It is not permissible to break down or attempt to tighten a riveted link in a run of chain.

6.6 **Proof Loading**

It is not necessary to proof load a chain after removal for routine examination. However, if it is desired to replace a portion only of the assembly, proof loading of the complete assembly is necessary. The proof load (Table 1) should be evenly applied and unless this can be assured, it is considered preferable to fit a complete new assembly.

6.7 **Protection and Storage**

After the chain has been cleaned, inspected and found to be acceptable, it should be thoroughly soaked in an appropriate oil, time being allowed for the lubricant to penetrate to the bearing surfaces. If not required for immediate use, the chain should be laid on a flat surface, carefully coiled and wrapped in greaseproof paper, care being taken to ensure the exclusion of dirt and the prevention of distortion, during storage.

7 **Installation of Chain Wheels and Pulleys**

7.1 During installation, chain wheels and pulleys should be checked to ensure that they are attached in the manner and method specified by the relevant drawings. The correct positioning of chain wheels is of particular importance when non-reversible chains are used (see paragraph 4.3). During maintenance, chain wheels should be checked for security and wear on the teeth. Pulleys should be checked for damage and excessive wear on the walls and on the chain guide section. The continued efficiency of ball races should also be ascertained.

INTENTIONALLY LEFT BLANK

Leaflet 20-50 Hose and Hose Assemblies

1 Introduction

1.1 This Leaflet provides guidance and advice on the installation and maintenance of hose and hose assemblies in aircraft and should be read in conjunction with the relevant manuals for the aircraft concerned.

NOTE: In this Leaflet the term 'hose' is used to describe a flexible tube which may be used on its own in some locations and the term 'hose assembly' is used to describe the hose complete with end fittings. Some manufacturers use the terms 'flexible pipe' and 'flexible pipe assembly' to describe the same parts.

1.2 Factors which affect the service life and reliability of hose and hose assemblies include the conditions prevailing in the area in which they are installed, the care with which they are installed and maintained and the pressures, temperatures and externally applied loads to which they are subjected in service. The need for scrupulous cleanliness at all stages during the lives of the hoses and hose assemblies cannot be over-emphasised.

1.3 Paragraphs 2 to 9 of this Leaflet deal with rubber and synthetic material hose assemblies. Metallic hose assemblies differ considerably with regard to manufacture, installation and maintenance and are dealt with separately in paragraph 10.

1.4 Guidance on the installation of rigid pipes is given in Leaflet 20-60.

2 General

2.1 Hose assemblies for use in high-pressure fluid systems are usually supplied by the manufacturers complete with end fittings which, in most cases, cannot be dismantled or altered in any way. However, there are some types of hose assemblies on which the end fittings may be changed, if necessary and these are dealt with in paragraph 9.

2.2 Hose Assemblies

2.2.1 Modern high-pressure, metal-reinforced rubber or synthetic material hose assemblies are designed for the widest possible application in aircraft and engine manufacture. The tube or lining of the hose is manufactured from material such as synthetic rubber, which is specially compounded to withstand the deleterious effects of high pressures, high temperatures, oils, solvents, fuels and other fluids. The hose is considerably strengthened by the incorporation of high tensile steel wire braiding or spiral lay, which provides maximum resistance to bursting, together with minimum dimensional alterations when the hose assembly is subjected to high internal pressure. Hose assemblies are generally designed either for specific functions or for a limited range of functions only and it is essential to ensure that only the hose specified on the appropriate drawing or in the approved parts catalogue is fitted in any particular system and location.

2.2.2 One material which is widely used for the manufacture of hose for engine and hydraulic systems is polytetrafluoroethylene (PTFE). This material is chemically inert, is unaffected by the synthetic oils and fluids used in aircraft systems, operates satisfactorily at high fluid and ambient temperatures and normally has an unlimited shelf life. PTFE hose is, however, more susceptible to damage from careless handling than rubber hose and great care is required during removal, installation and inspection.

- 2.2.3 The operating conditions under which a hose assembly may have to function vary considerably. Fluids may have to be conveyed at very high pressures at altitude where the ambient temperature may be in the region of -55°C ; on the other hand high ambient temperatures in the region of jet engines may affect the same hose assembly. Hose assemblies required to function in designated fire zones or adjacent to fireproof bulkheads must possess fire-resistant properties and are usually fitted with a protective sleeve; these sleeves are usually made from woven asbestos, are covered with asbestos-impregnated synthetic or silicone rubber and may be secured to the hose assembly by clips.
- 2.2.4 In addition to the pressures and temperatures to which hose assemblies are subjected, vibration and in some cases appreciable angles of flexing, may have to be accommodated. It is, therefore, essential that the lives specified for these assemblies in the approved Maintenance Schedule should not be exceeded.

2.3 **Manufacture of High-pressure Hose Assemblies**

- 2.3.1 A typical high pressure hose assembly (Figure 1) consists of an inner tube or lining covered by one or two closely-woven wire braids, either moulded or sandwiched between the synthetic rubber of the tube, or woven on the surface of the tube. The whole may be enclosed by an outer cover, the purpose of which is to provide protection for the other parts of the hose, to resist abrasion and the effects of weather and environmental fluids and chemicals and in some cases, to provide a degree of fire resistance. In some cases cotton braid is introduced between the wire braids and the rubber inner and outer tubes and a thin rubber layer may be interposed between layers of wire braid.

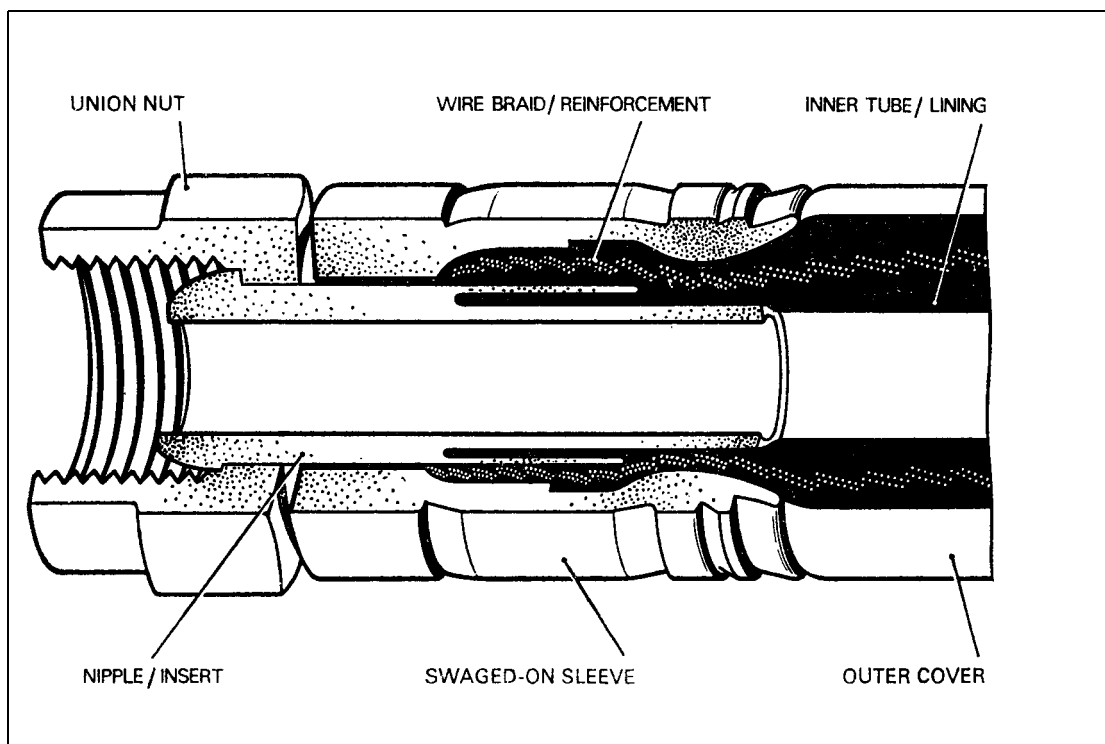

Figure 1 High Pressure Hose Assembly

- 2.3.2 The end fittings on a hose assembly are made of steel or light alloy, depending on the application and they are designed to exert a grip on both the tubes and wire braids so as to resist high pressure, twisting and vibrating loads and to provide an electrical bond throughout the assembly.

2.4 Measurement of Length

The length of hose assemblies with straight end fittings is taken as the distance between the extremities of the two nipples. In the case of elbowed end fittings the length is taken from the centre of the bore (see Figure 2).

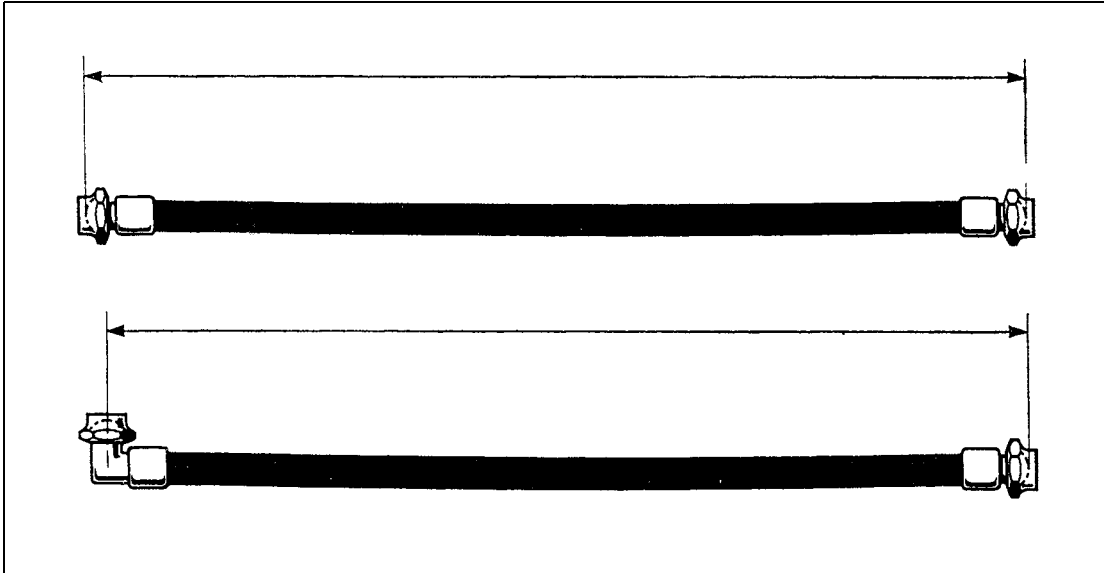

Figure 2 Measuring Hose Assemblies

2.5 Low-pressure Hose

2.5.1 There are many types of low-pressure hose used on aircraft, e.g. the thin-walled textile reinforced type used for instrument lines (especially for instruments mounted on panels equipped with vibration isolators) and the rubber or canvas spirally-corrugated hose having a spiral of spring steel embedded in the corrugations, which is often used for systems where there are negative pressures.

2.5.2 With low-pressure hose it is important to ensure that bends are not too acute, since this may result in kinking of the hose or flattening of the cross-sectional area at the bend. Where sharp bends cannot be avoided an internal support coil may be included in the design.

3 Storage of Hose and Hose Assemblies

3.1 PTFE hose does not normally have a specified storage life, but rubber or synthetic rubber hose normally has a storage life, depending on the formulation of the material, of between 3 and 5 years. The storage details relevant to a particular hose or hose assembly should be obtained from the appropriate Maintenance Manual or manufacturer's manual and any instructions relating to the inspection and testing of hose or hose assemblies while in storage or prior to installation should be carefully observed. The storage life of hose supplied in bulk is calculated from the cure date and the storage life of hose assemblies is calculated from the date of manufacture or assembly.

3.2 Storage Conditions

3.2.1 Bulk supplies of hose are generally stored in coils of large diameter, but hose assemblies should be stored flat and relieved of stress. Hose and hose assemblies should be stored away from strong light and running electric motors and air should be

permitted to circulate freely about the parts unless they are contained in plastics envelopes. The temperature should be controlled between 10°C and 26°C.

- 3.2.2 Preformed hose assemblies and PTFE hose assemblies which are being stored after removal from an aircraft system must be stored in such a way that the required or assumed shape is maintained; no attempt should be made to straighten or bend these hoses. A length of locking wire may be attached between the end fittings to prevent the hose from straightening.

3.3 **Sealing Blanks**

During storage, the correct sealing blanks should be fitted. Plugs and caps conforming to appropriate AGS and AS Specifications are usually suitable, but in instances where the standard blanks cannot be used, blanks should be so designed that they cannot enter the end fitting or be left in position when the assembly is connected. It is also important to ensure that the material used for blanking will not 'pick-up' or otherwise tend to leave small particles inside the end fitting after long periods of storage. Tape or rag must not be used for blanking purposes.

3.4 **Rotation of Stock**

Strict rotation of issue from stores must be observed to ensure that older stock is issued first.

3.5 **Bore Protection**

In some special cases, to prevent deterioration of the bore or inner lining of the hose, it may have to be stored filled with the liquid which it is intended to contain in service; special instructions concerning such assemblies will normally be attached by the manufacturer. If a hose assembly is issued in an airtight plastics envelope, this should not be removed until the part is fitted. Should the envelope become damaged during handling, any desiccant contained within should be checked for condition and the envelope should be re-sealed or renewed.

4 **Markings on Hose and Hose Assemblies**

- 4.1 There are many ways in which the date of manufacture is marked on hoses and hose assemblies, varying according to the type and manufacture of the item. The date may be stencilled on the external surface, or impressed on a tab or band secured to the hose; in instances where the external surface is of cotton braid some of the 'strands' are woven in black and some are coloured to indicate the month and year of manufacture.
- 4.2 In addition to the date of manufacture, hose assemblies are marked with the drawing number or part number, inspection stamp, 'test' stamp and name of manufacturer.
- 4.3 Most hose assemblies are marked along their length with one or more continuous thin lines to indicate any twist which may occur on installation. Some manufacturers use these lines also for manufacture identification (see Figure 4), e.g. a hose having a single high-tensile wire braid would be indicated by a single line, while a hose having a double wire braid would be indicated by a double line.

5 **Pre-installation Checks**

- 5.1 Before a hose assembly is fitted to an aircraft it should be examined for damage and corrosion and for cleanliness. The part number, date of manufacture and date of last

test should also be ascertained. Where specified by the manufacturer, hose assemblies should be pressure tested before installation (see paragraph 8).

- 5.2 Where possible, every hose assembly should be examined internally to ensure that the bore is free from obstruction or damage. Straight hose assemblies may be examined by looking through them with a light positioned at the opposite end, but preformed hose should be checked by means of a ball test (paragraph 9.5.3 a)).
- 5.3 If the end fittings have been welded, brazed or silver soldered, they should be examined for any corrosion which may have developed during manufacture. An Introscope or similar inspection instrument should be used in cases where direct viewing is impractical.
- 5.4 The hose bore should be examined for cleanliness, blown through with clean, dry compressed air as necessary and, when recommended by the manufacturer, flushed with clean fluid of the type used in the system to which the hose assembly is to be fitted.

6 Installation

- 6.1 When installing a hose assembly, it should be ensured that there is adequate clearance between the hose and other parts of the aircraft structure, so as to prevent chafing or electrolytic corrosion. It must be borne in mind that hose may flex when internal pressure is applied and considerable 'whip' may occur under surge conditions; the force exerted when a hose 'whips' may be sufficient to cause damage to the hose assembly and to surrounding components.
- 6.2 The serviceability and life of a hose assembly is considerably affected by the degree of bending of the hose. There may be some variation in the connecting angle and distance between fittings for a particular hose assembly in similar installations and a check should be carried out to ensure that the bend radius is not less than the minimum specified by the manufacturer.
- 6.3 There are two classes of minimum bend radii recommended by hose manufacturers for each hose diameter. The minimum bend radii recommended for hose in locations where there is no relative movement, are smaller than those recommended for hose in locations where there is relative movement between end fittings, e.g. a hose assembly connected to a flap actuator would have a larger radius bend than a hose assembly connecting two rigid couplings at different angles. The flexing radius should, in general, be twice the bend radius of a static installation. It should also be noted that the recommended minimum bend radii for PTFE hose may vary from those recommended for rubber hose.
- 6.4 It is important to ensure that the bend radius of hose fitted to moving parts is never less than the recommended minimum, throughout the range of movement of the parts. Correct and incorrect methods of installation are shown in Figure 3, where the different alignment of the hose assemblies resulting from movement of the attached parts is illustrated.
- 6.5 To allow for shrinkage, vibration, movement of parts and 'whip', all straight hose assemblies should be at least 3% longer than the maximum distance between the fittings to which they are connected. In no circumstances may a hose assembly be under any form of tension (see Figure 4(B)).
- 6.6 Sharp bends in a hose adjacent to an end fitting must be avoided, as this can cause considerable local strain and rapid failure of the hose (see Figure 4(D)). When fitting

hose assemblies with different types of end fittings, the correct method of installation should be observed.

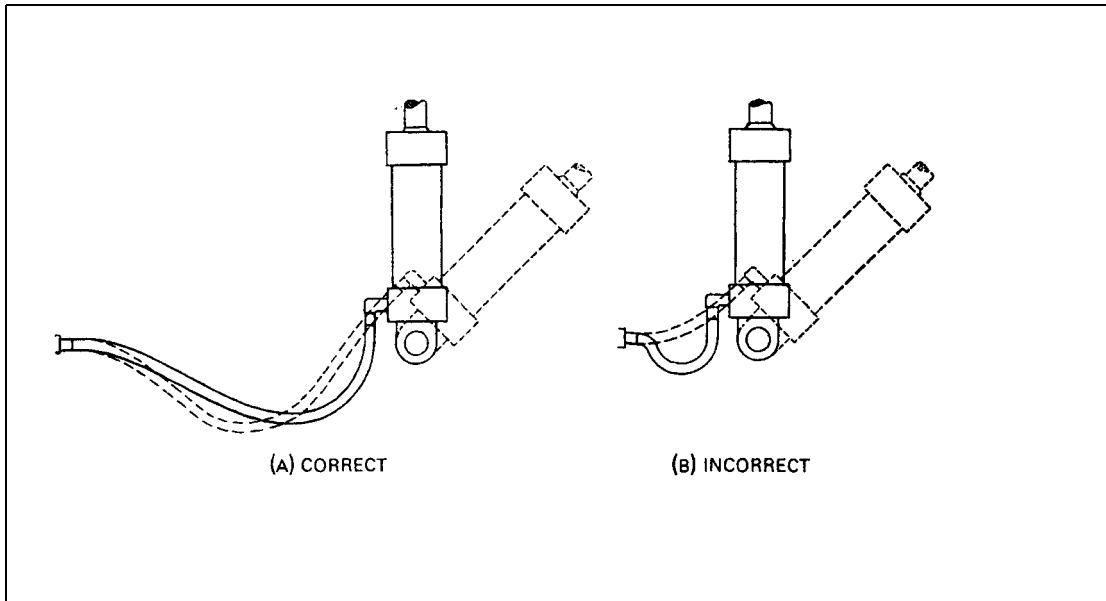

Figure 3 Correct and Incorrect Installations

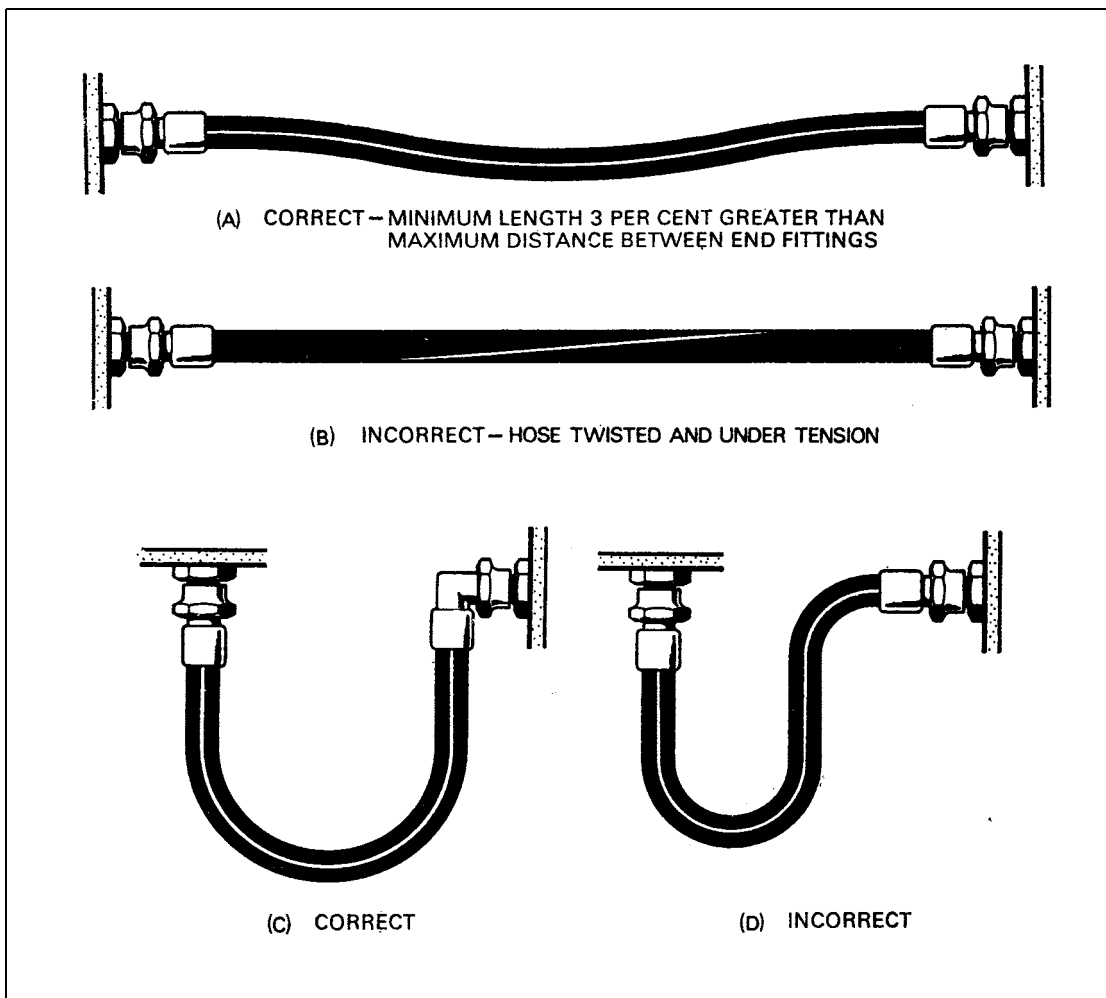

Figure 4 Correct and Incorrect Installations

6.7 Lubrication of Couplings

If the lubrication of coupling threads is specified to avoid 'picking up', it is essential to use the lubricant specified by the manufacturer and to ensure that it does not enter the bore of the hose assembly; this can be done by applying lubricant to the external threads only. For connections in oxygen systems, where the presence of oil or grease is very dangerous, only specified lubricants may be used. Because of the sensitivity of oxygen to many substances, it is essential that the instructions given in the relevant manual are followed when applying these lubricants.

6.8 Tightening of Couplings

6.8.1 When fitting a hose assembly, it is most important to prevent it from twisting when the connections are tightened. The union nuts at each end should be fitted finger-tight and then, while holding the hose portion firmly as near to the coupling as possible, the union nuts should be tightened with a spanner. On some hose end fittings, flats are provided for holding the hose with a second spanner while tightening the union nuts.

6.8.2 The continuous coloured line which some hose assemblies have on their outer cover will assist in detecting any twist in an installed hose (see Figure 4(B)). In the case of hose with a metal braided outer cover, twist may be detected by distortion of the braid pattern in a helical direction, but careful tightening or loosening of the union nuts is the only safe way of avoiding twist and strain in the hose assembly.

6.8.3 Care must be taken when tightening union nuts or banjo bolts, to avoid damage to the nuts, bolts or threads. Spanners should be of the correct size and in good condition and the bolts and nuts should be tightened to the appropriate torque as specified in the relevant manual.

6.9 Support Guides

6.9.1 In many installations, a hose is supported or retained by large 'U' fittings or guides fitted to the adjacent structure to guide the movement of the hose in a particular plane and to prevent it fouling or catching other moving parts of the aircraft installation. These support guides are usually encased in synthetic rubber to prevent damage to the hose. It is important to check the positioning of these support guides in relation to the angular movement of the hose to ensure that the hose movement is not restricted at extreme angles.

6.9.2 Clipping

In some installations, where there is no relative movement of the hose assembly, the hose is clipped to give support and minimise vibration. It must be ensured that, where clips are fitted, the hose is not distorted by overtightening or poor positioning of the clip.

6.9.3 Taping

Where taping of a hose is considered necessary as a protection against fouling, this should be reduced to a minimum, since, apart from restricting the hose flexibility, deterioration of the hose under the tape often occurs. On no account should leather be used for this purpose, since acid from the leather will corrode any metal parts with which it comes into contact.

6.9.4 Movement of Hose Assemblies

Where a hose assembly is connected to a moving part, it is important to ensure that the hose can only move in the plane or planes intended in the design.

- a) In the case of a hose assembly having movement in more than one plane, torsional loads will be imposed on the hose at the end fittings. If such movement is the design intention, a hose which has no metal braid or wire spiral in its manufacture is generally used, otherwise the torsional effect would result in early deterioration. In such instances special attention should be given to the locking of end fittings.
- b) Each moving hose should be observed during the functioning tests of the component to which it is connected so that it can be checked throughout its travel for evidence of chafing, binding, tight bends and other deleterious effects. An important application of these checks is to brake hose assemblies, which may appear to be of adequate length when the aircraft is resting on its wheels, but may be too short when the undercarriage strut is fully extended. It should be borne in mind, however, that an excessively large loop in the hose may be hazardous during retraction of the undercarriage.

6.9.5 Tests after Installation

After installation of a hose assembly, the associated system should be tested for flow, pressure and bonding as specified on the appropriate drawing or in the relevant aircraft manuals. During tests, freedom from leaks and excessive movement under pressure should be verified.

NOTE: In positions where the hoses cannot be seen with the system in operation, every possible precaution must be taken to ensure safety in the known most adverse condition of operation.

7 Maintenance

7.1 The life of a hose assembly varies largely according to environmental and operating conditions, but may also be affected by storage conditions and the care taken during its installation. The life is assessed from experience with a particular installation and it may be specified in a number of ways. Some hose assemblies are given a definite life after which they are scrapped regardless of their apparent condition, some are given an overhaul life which usually coincides with the aircraft overhaul periods and some are renewed only 'on condition'; the life applicable to a particular hose assembly will be specified in the approved Maintenance Schedule. Apart from the replacement of time-expired or unserviceable hose assemblies little maintenance is possible, except in some cases, the replacement of end fittings and protective sleeves, but regular inspections of the condition of the assembly should be carried out and care should be exercised during its service life to prevent deterioration through abuse.

7.2 Inspection

7.2.1 The inspection of hose assemblies should normally be carried out in situ, at the intervals specified in the approved Maintenance Schedule. During each inspection the date of manufacture of hose should be checked to ensure that its prescribed life will be valid until the next inspection and the assembly should be examined for defects as outlined in paragraphs 7.2.2 to 7.2.10.

7.2.2 General Condition

General deterioration of a hose may be recognised by discoloration, flaking, hardening, circumferential cracking or crazing of the outer cover (Figure 5). These defects do not render the hose unserviceable unless the cracks penetrate to the braid.

7.2.3 Installation

The installation of a hose assembly should be checked to ensure that it is not twisted, stressed, or bent through too sharp an angle and that any clips or supports are correctly fitted and not chafing or imposing stress on the hose.

7.2.4 Chafing and Cuts

Light chafing and cuts in the outer cover are generally acceptable if the braiding is not exposed, but the reasons for the damage should be ascertained and corrected. In the case of hose assemblies which have no outer covering over the braid, any damage to the braid will normally entail rejection, but some manufacturers permit the acceptance of isolated broken strands. Chafing which occurs under clips may entail changing both the hose and the clips.

7.2.5 Kinks

This defect is usually caused by incorrect installation or by mishandling. It shows up as a sharp increase in radius at one point in a bent hose and is usually easy to detect visually unless the hose has a protective cover; finger pressure should be used to check this type of hose. Any kinked hose must be considered to be permanently damaged and must be scrapped.



Figure 5 Ageing Cracks

7.2.6 Corrosion

Hose assemblies with corroded wire braid, or end fittings which are corroded (other than very lightly and locally) must be scrapped.

7.2.7 Contamination

Contamination of a hose with an outer rubber cover will show up as swelling, sponginess, hardening or disintegration of the surface and is not acceptable. Hose which is contaminated should be rejected and renewed.

7.2.8 Overheating

The overheating of rubber covered hose is apparent as scaling, crazing, or discoloration of the surface. Hose with an outer wire braid may assume an overall golden brown colour when exposed to normally high temperature and this is acceptable; patches of discoloration caused by overheating are not acceptable.

7.2.9 Blisters

Blisters may form on the outer synthetic rubber cover of hoses, but these do not necessarily affect the serviceability of the hoses provided they are able to withstand the applicable test described in a) or b). Certain factors must be taken into consideration, however, e.g. if the hose is exposed to spray from the tyres, puncturing of the outer cover may allow corrosive elements to attack the wire braiding.

a) Hose Assemblies in Pneumatic Systems

- i) Remove the hose assembly from the aircraft and puncture the blister with a needle having a chisel point. The needle should be inserted parallel with the outer cover of the hose so that it penetrates the outer cover only. The blister should then collapse.
- ii) Pressurise the hose at 1½ times working pressure under water.
- iii) When the hose is pressurised, the air supply should be turned off. Bubbles will appear from air trapped beneath the outer cover but eventually disappear if no further bubbles appear, the hose is serviceable.
- iv) A constant flow of air bubbles indicates a leak and can be observed as a pressure drop on the pressure gauge. A leaking hose must be scrapped.

b) **Hose Assemblies in Hydraulic Systems.** Remove the hose from the aircraft and puncture the blister as outlined in a). If fluid emerges from the pin hole the hose must be scrapped; if air only emerges the hose should be pressurised with fluid at 1½ times its maximum working pressure for a period of two minutes and, if no fluid leakage occurs, it can be regarded as serviceable.

7.2.10 Leaks

A hose assembly should be checked for leakage with pressure in the associated system. A leak may be detected by the presence of fluid on the hose, end fittings or adjacent structure, or by the appearance of blisters on the hose (paragraph 7.2.9). When a protective sleeve is fitted, stains may appear on the sleeve or fluid may emerge from the ends of the sleeve, but if the leak is small and no fluid is visible, the presence of fluid may sometimes be detected by squeezing the sleeve. Hose assemblies in pneumatic systems may be checked by applying, externally, a noncorrosive soapy water solution, by the use of special test equipment, or by carrying out a leak rate check. If there is any doubt the hose assembly should be removed from the aircraft and subjected to a pressure test (paragraph 8). A leaking hose must be scrapped.

8 Pressure Tests

8.1 General

When specified in the approved Maintenance Manual or Schedule, or whenever the serviceability of a hose assembly is in doubt, a pressure test should be carried out.

8.2 Test Equipment

8.2.1 Before pressure testing a hose assembly the following points should be verified:

- a) that the test equipment available is adequate for the proposed tests and located in such a position as to preclude cross-contamination with dissimilar fluids,
- b) that the test medium is clean and suitably protected against the ingress of dirt,

- c) that the test equipment and instruments are checked at regular intervals and a record kept of these checks and
 - d) that before any tests are made, either in the aircraft or on separate components, the test figures are ascertained from the appropriate drawings or manual.
- 8.2.2 To prevent injury to personnel in the event of a hose failure during the pressure testing of a hose removed from an aircraft, the hose should be located behind a heavy plastics screen. For tests using air as the test medium the hose should also be submerged in water.

8.3 Test Medium

- 8.3.1 Pressure tests are usually made with a fluid similar to that which the hose will carry in service. However, there are some exceptions, for example, paraffin is usually recommended for testing petrol hoses as it is safer and more searching. Pneumatic and oxygen hoses are usually tested with water then thoroughly dried out with a warm air blast. This is followed by a further test with clean, dry air, in which pressure is limited to maximum system pressure.
- 8.3.2 Oxygen pipes must not be contaminated with oil and should not be connected to a compressor for test purposes.

8.4 Hose Flexing

- 8.4.1 When under test, the hose should be restrained to approximately the shape it assumes in service. If the hose is non-flexing in service it should be flexed approximately 15° from its normal shape several times each way and the pressure should be maintained for at least two minutes. Low pressure non-flexing hoses used in regions of high ambient temperature should be regarded as exceptions and should not be subjected to flexing during pressure testing, since such hoses, having been subjected to extremes of heat during service, will automatically be rendered unserviceable if treated in this manner.
- 8.4.2 Hoses which are subject to flexing in service should be tested in a similar manner but, in addition, should be flexed through their normal flexing angle plus 15° each way.
- 8.4.3 No leakage or malfunction should occur during any of these tests.

8.5 Test Pressures

Unless otherwise stated on the appropriate drawing or in the relevant manual, hoses should be pressure tested to 1½ times their maximum working pressure. In some instances hose assemblies are tested in situ, in which case one end should be connected to a universal type of inflation adapter gauge and the other shut off or blanked as required. For information on the universal type of adapter and gauge see Leaflet 20-60.

9 Re-usable End Fittings

9.1 General

The purpose of re-usable end fittings on hose assemblies is to save the cost of renewing a complete assembly when only the hose portion is unserviceable. An end fitting consists basically of two or more components; a socket fits tightly over the hose and a tapered nipple (or insert), when screwed into the hose bore, expands the hose and clamps it firmly against the socket. This is the most common method and is known as a 'compression seal' (Figure 6 (A) and (B)), but a somewhat different method of attachment, known as a 'lip seal' (Figure 6 (C)), is used by some

manufacturers; the nipple in this case has a cutting spur or separate collar which separates the inner hose from the braid during the assembly operation. The re-use of end fittings is satisfactory if precautions are taken to ensure that no damage is caused to the hose bore during the assembly operation and the manufacturer's instructions are followed with regard to both assembly and testing. A brief description of a typical assembly technique is given in the following paragraphs and illustrated in Figures 6, 7 and 8, but reference should always be made to the aircraft or hose manufacturer's manuals for specific instructions on measurement, assembly, lubricants, tools, etc.

9.2 **Hose**

- 9.2.1 The new hose must first be carefully measured and cut to length with a fine-tooth hacksaw or specialised cutting equipment, ensuring that the cut-ends are square and smooth. It should then be thoroughly cleaned and blown out with dry compressed air.
- 9.2.2 To minimise fraying when cutting off hose which has a cloth or metal sheath, it is advisable to wrap the hose with masking tape and saw through the tape.
- 9.2.3 High pressure hose usually has a metal braid sheath and, when this has a protective rubber cover, the cover must often be removed to enable the hose to enter the socket. Using a sharp knife, the cover should be cut off to the depth of the socket and the exposed braid carefully cleaned with a wire brush. Care must be taken to avoid damage or displacement of reinforcement wires.

9.3 **Fitting Sockets**

- 9.3.1 Sockets usually have a form of coarse left-hand internal thread to grip the outside of the hose and threads at the outer end of the bore which mate with threads on the nipple.
- 9.3.2 To prevent the ingress of moisture on hoses which have a metal braid sheath, it is sometimes recommended that a sealant is applied to the braid and socket bore before assembly.
- 9.3.3 Large bore hoses are quite rigid and, to facilitate entry of the nipple, it is often recommended that the hose is slightly flared and its bore carefully chamfered before assembly into the socket. Except where a sealant is specified, lubrication of the outer surface of large diameter hose will also ease its assembly into the socket.
- 9.3.4 Actual assembly of the hose and socket is carried out by holding the socket firmly in a vice and screwing the hose into the socket until it bottoms.
NOTE: Some manufacturers recommend that, after screwing the hose fully into the socket, it should be unscrewed a quarter turn to allow for expansion when the nipple is inserted.
- 9.3.5 After assembly of the hose to the socket it is recommended that the hose is marked with a grease pencil, paint or tape, at the point where it enters the socket, in order to provide a means of checking that the hose is not forced out of the socket during subsequent insertion of the nipple.

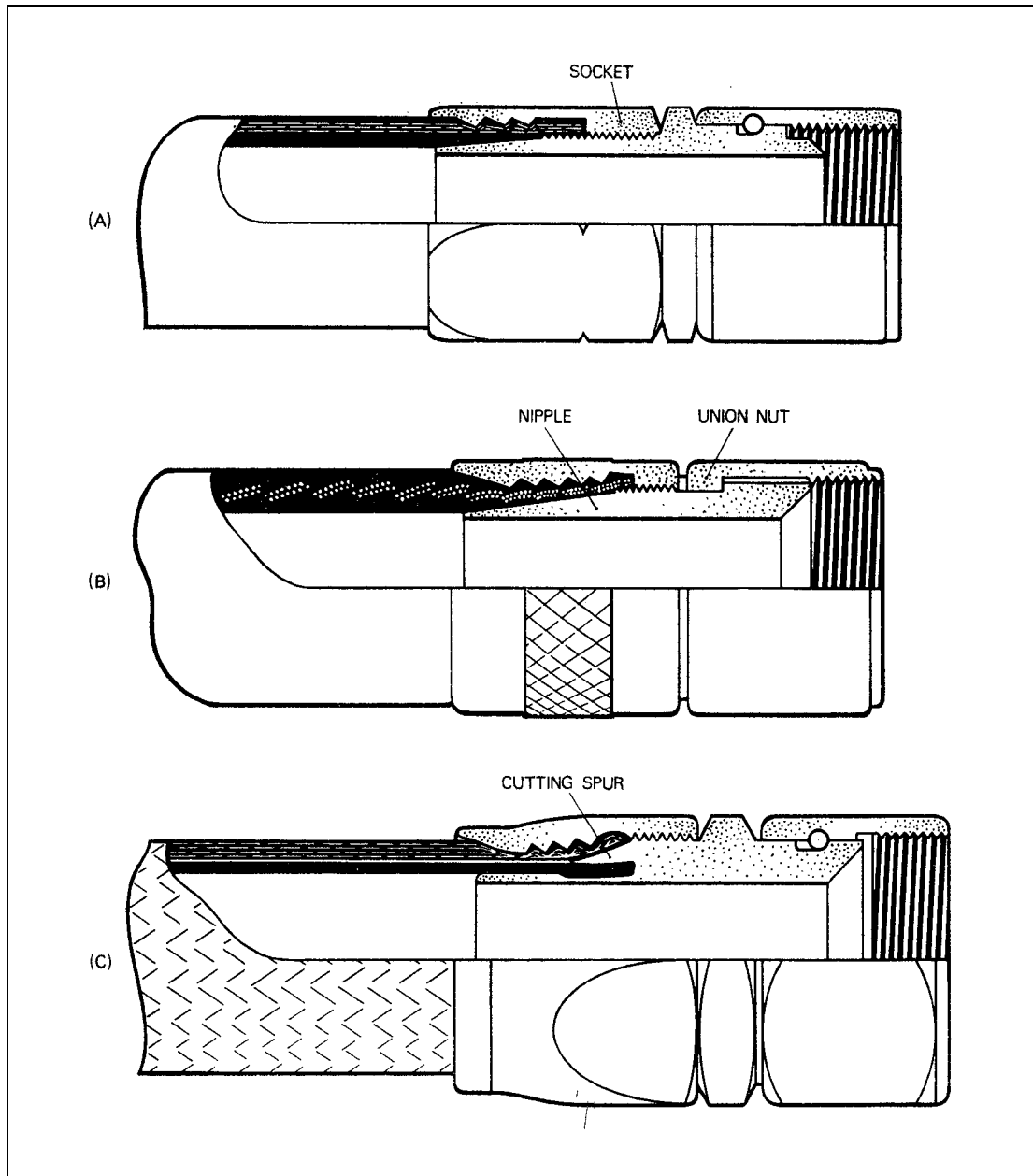

Figure 6 Typical Re-usable End Fittings

9.4 Fitting Nipples

9.4.1 To complete the hose assembly, nipples must be screwed into the previously assembled hose and socket. This operation must be carried out with extreme care, as misalignment of the nipple could easily result in its tapered end cutting into the hose wall; slices of rubber dislodged in this way have been known to cause malfunction of associated components.

9.4.2 Nipples are usually tapered over approximately half their length and are often provided with a plain pilot extension to guide the nipples accurately into the hose (Figure 7). When the nipple does not have a pilot extension, an assembly mandrel should be used and should extend at least 6 mm ($\frac{1}{4}$ in) beyond the end of the nipple. The assembly mandrel also acts as a means of turning a nipple which does not have an integral hexagon or flats.

NOTE: Because of their design, lip seal fittings do not require the use of an assembly mandrel.

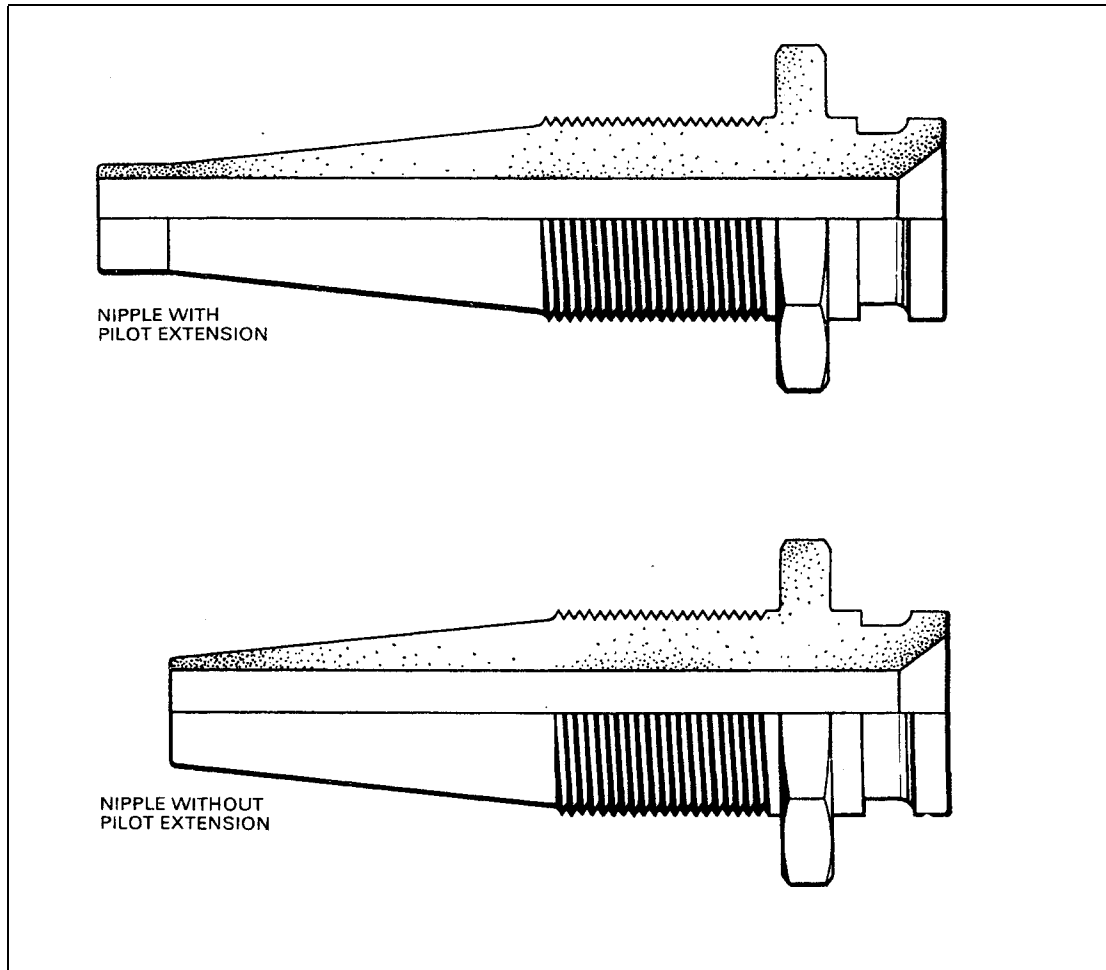

Figure 7 Nipple Characteristics

- 9.4.3 Angled nipples are always provided with a pilot extension because an assembly mandrel cannot be used, but some manufacturers recommend that a straight nipple should be partially inserted first, to ensure that a concentric thread is started in the hose bore.
- 9.4.4 To assemble a nipple, the hose and socket should be held in a vice and, where appropriate, the nipple screwed onto a mandrel of the correct size (Figure 8). The hose bore and nipple should then be liberally lubricated with the recommended lubricant and the nipple screwed carefully by hand into the hose and socket until the threads on the nipple engage with those in the socket. The nipple should then be screwed fully home by use of a spanner or tommy bar as appropriate. With the lip seal type of fitting the hose should be pressed firmly into the socket during this operation and particular care taken when engaging the socket threads.

- 9.4.5 Check by reference to the mark applied to the hose (paragraph 9.2.4) that the hose has not been pushed out of the socket during insertion of the nipple.

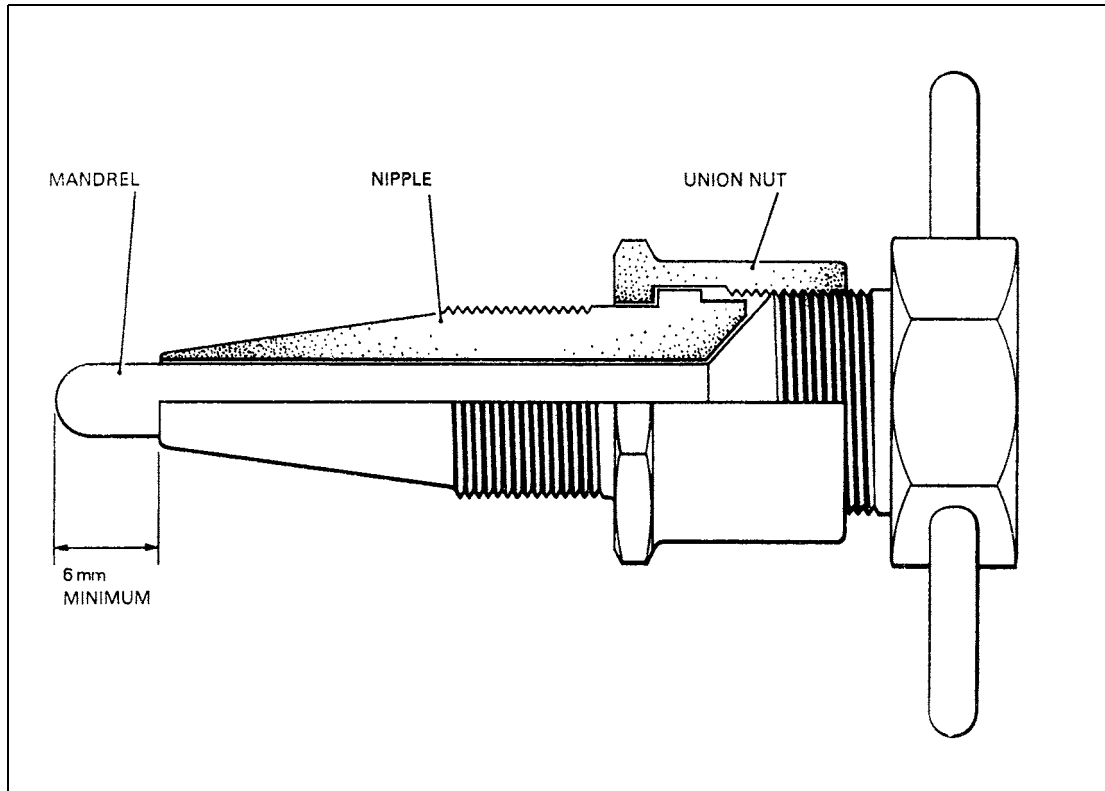

Figure 8 Assembly Mandrel

9.5 Inspection

- 9.5.1 Sockets and nipples which have been removed from an unserviceable hose should be inspected for damage and corrosion and any traces of hose adhering to the threads must be removed. Before re-using a lip-seal type of nipple all traces of rubber should be removed from under the lip and, subject to limitations laid down by the hose manufacturer, the lip should be restored to its original profile. After the hose assembly has been made up it should be thoroughly cleaned and dried, examined and pressure tested to $1\frac{1}{2}$ times maximum system pressure, to ensure that it will withstand the pressure existing in the system with which it is to be used.

9.5.2 External Inspection

- Check all metal parts for signs of damage, particularly of the union nuts and cone faces.
- Check that the union nuts turn freely.
- Check that the gap between the socket and union nut (or integral hexagon) is within limits.
- Check the hose for damage at its point of entry into the socket.

9.5.3 Internal Inspection

Internal bulges and flaps can often be detected by looking through the hose with a light held at the opposite end, but a more satisfactory examination can be made using normal inspection equipment (e.g. an Introscope). Hoses which have straight nipples may be readily examined and hoses which have one angled nipple may be examined from the opposite end. Hoses which have an angled nipple at both ends, however,

present difficulties and although radiological examination would show if the nipple had been assembled eccentrically it might not reveal damage to the hose bore and would in any case defeat the object of using re-usable fittings. In these cases either a ball test or a flow test is recommended.

a) **Ball Test**

- i) With the hose assembly suspended from one end, a ball should pass freely through the assembly under its own weight and without lubrication. The check should be repeated from the opposite end and if the ball fails to pass through the hose in either direction the hose must be rejected as unserviceable.

NOTE:Precautions must be taken to ensure that a hose in which a ball has become lodged is not introduced into service; the hose should be cut immediately and the ball extracted.

- ii) The diameter and material of the ball are specified by the hose manufacturer and vary with the design of the hose, but a steel ball having a diameter of approximately 90% of the bore of the end fittings is generally used.

NOTE:It is sometimes recommended that a rod should be used on small diameter hoses.

- b) **Flow Test.** In some instances a ball test may be considered to be inadequate and it may be required to be demonstrated that the assembly is capable of passing a given quantity of fluid in the time and under the conditions specified.

9.5.4 **Pressure Test**

Hose assemblies with re-usable end fittings should be given pressure tests identical to those described in paragraph 8 for normal hose assemblies.

9.5.5 **Bonding Test**

Where hose assemblies have metal wire braid reinforcing or embody any form of metal in their manufacture (such as a wire spiral) a bonding test will be specified. An approved type of bonding tester should be used and the resistance recorded should not exceed 0.050 ohm or 0.025 ohm per foot length, whichever is the greater.

10 Flexible Metallic Hose Assemblies

- 10.1 This type of flexible hose is made entirely of metal, mainly stainless steel and must, therefore, be treated separately from the synthetic rubber and metal composite flexible hoses dealt with in the previous paragraphs.

10.2 **Manufacture**

- 10.2.1 Flexible metallic hose is manufactured from an annular or spirally convoluted, seamless, flexible inner tube, reinforced by an exterior covering of one or more layers of stainless wire braid.

10.2.2 **Reinforcing Overbraid**

Unless restrained by some means, the effect of internal pressure on the convoluted tube would cause elongation and the convolutions would tend to flatten out. Such elongation is prevented by means of a layer, or layers, of wire braid, which is braided upon, or slipped over the inner tube and securely anchored at the end fittings. Special attention is given during the manufacture of the hose to braid tension, pitch angle and final diameter to ensure that change of length of the assembly under pressure is kept to a minimum. This practice obviates the possibility of premature fatigue failure

induced by excessive 'panting' and, in addition, 'fretting' on the convolution crests is avoided.

10.2.3 **Function**

The wire overbraid counteracts any tendency of the inner tube to elongate under pressure by containing the end loads thus produced between the fittings. The overbraid also performs other important functions, such as providing protection against damage for the inner tube and by the exertion of a considerable damping influence on the inner tube when the assembly is under the effects of vibration and pressure impulse.

10.3 **End Fittings**

Various types of steel end fittings are available and are designed to effect a pressure-tight seal at the end of the hose. The seal is achieved by mechanical means or by brazing, silver soldering or welding the fitting to the tube. The end fitting also provides an anchorage for the wire braid to take the end loads caused by internal pressure.

10.4 **Storage**

Assemblies which are to be stored should preferably be left in the boxes in which they are received, but in any case they should have their sealed plastics envelopes intact. Under these conditions, the assemblies have no life limitations, provided that normal steps have been taken to prevent corrosion due to atmospheric conditions, physical damage, etc. It is also important in the event of the plastics envelope having been removed or damaged, to fit approved blanks; adhesive tape or rag should not be used.

10.5 **Identification**

Each assembly has a tag, brass band or adhesive label attached to it on which appears the part number of the assembly, the date of manufacture, the manufacturer's name and inspector's stamp.

10.6 **Pre-installation Check**

Before a hose assembly is fitted, the following checks should be made:

- a) Verify the part number is correct to the drawing or the appropriate manual.
- b) Remove the blanking plugs or caps and ensure that the end fittings are undamaged and free from corrosion. Special attention should be given to the seating faces.
- c) As far as possible, examine the bore for corrosion.
- d) Carry out the pre-installation pressure test, according to the instructions given on the drawing or in the manual.

NOTE: Prior to fitting, cleanliness of the assembly is imperative.

10.7 **Installation**

10.7.1 When 'offering-up' the hose assembly, particularly if considerable manipulation is required to fit it within a confined space, care must be taken to ensure that the minimum bend radius is not less than that specified. Flexible metallic assemblies comprise thin-section, highly-stressed metal components and it is imperative that they are not stressed beyond their elastic limits.

10.7.2 Union nuts at the end fittings should be hand-tightened at both ends and the hose should lie in a natural manner before the union nuts are finally tightened. Due to its manufacture, metallic hose will always tend to lie in its natural manner, but care is required to ensure that no twist is applied to the hose during final tightening.

- a) Where provision is made for the use of two spanners, one on the end fitting and one on the union nut, a spanner should always be used on the end fitting to steady the assembly and prevent twisting of the hose on final tightening.
- b) Where no provision is made for the use of a spanner on the end fitting, the hose should be firmly gripped by hand as near the end fitting as possible while the union nut is finally tightened.
- c) After tightening of the union nuts, a hose assembly should always be checked to ensure freedom from twist and tension. It must also be ensured that the end fittings are relieved of the weight of the hose and its contents by suitable supports.
- d) Thread lubricants should only be used if specified on the appropriate drawing or in the relevant manual (see paragraph 6.4).

10.7.3 Flanges

In the case of assemblies incorporating 'Vee' band flanges, the correct type of 'O' ring should be carefully positioned in the flange groove and the inner flange brought into alignment before placing the clamping device in position. This type of flange is produced both with and without means of positive lateral positioning – in the former case care must be exercised in engaging the spigot portion provided for the purpose.

10.7.4 Supports

Support clips, which may be either of the close-fitting type and support the hose positively, or of the loose guide type which will allow movement of the hose while containing it in a specific space, must be placed as prescribed on the appropriate drawing.

NOTE: Wire locking of union nuts should be made in the approved manner as described in Leaflet 51-100.

10.7.5 Bonding

After installation, a bonding check should be made between the assembly end fittings and between the end fittings and the components to which they are connected. The resistance should not exceed 0.050 ohm.

10.8 Inspection

10.8.1 When carrying out a visual inspection of flexible metallic hose assemblies installed on an aircraft, any of the following would be cause for rejection:

- a) Signs of distortion or damage of the wire braiding, or of the braiding being pulled away from end fittings.
- b) Leakage around end fittings.

NOTE: The hose should also be examined for signs of leakage at the lowest points in its run.

- c) Abrasion of the hose caused by contact with adjacent components.
- d) Signs of twisting of the assembly, generally visible as a distortion of the regular pattern of the overbraid in a helical direction.
- e) Corrosion of the external surfaces of the hose end fittings.
- f) Visible cracks or other damage pertaining to the end fittings.

NOTE: When hose assemblies are adjacent to the powerplant, a careful examination should be made for any discoloration caused by hot gas leaks which may occur at the shroud ring, exhaust cone or other parts of the engine.

10.8.2 Assemblies should be removed for detailed examination at the periods stated in the Maintenance Schedule or at any time the hose assembly becomes suspect. They

should be immersed in a clean non-chlorinated solvent and thoroughly agitated to loosen any oils or deposits on internal and external surfaces and to assist in flushing any deposits clear of the convoluted bore and other parts such as elbow fittings, etc. After cleaning, the assemblies should be inspected as indicated in a) to f).

NOTE: It is important not to use any form of internal brushing such as the type used for rifle or tube bore cleaning, as this may cause damage to the inner diameter of the convolutions when the rod or brush is pushed into the bore.

- a) Examine the end fittings for corrosion and damage.
- b) Examine all welded or brazed joints for damage, cracks or corrosion.
- c) Examine all threads for wear.
- d) Check that all mating surfaces (nipple faces) are undamaged.
- e) Examine the wire braid for chafing, dents and for looseness at end fittings.
- f) Examine the hose for corrosion and discoloration due to overheating.

10.8.3 Testing

Assemblies which are considered satisfactory after examination as above should be pressure tested at room temperature using the following procedure:

- a) Lay the assembly in a free position on a bench and couple it to a controlled pressure supply of a suitable test fluid, as defined by either manufacturer's requirements or hose usage. After washing through thoroughly, blank off the open end of the assembly. Unless otherwise stated on the appropriate drawing or in the relevant manual, it is usual to pressurise to 1½ times the system maximum working pressure. When the correct pressure has been reached, the pressure supply should be cut off and there should be no indication of a drop on the pressure gauge after a period of 5 minutes.
- b) If the hose assembly is part of a pneumatic or air conditioning system, it should be connected to a suitably controlled pressure supply of clean dry air and immersed in clean water or other suitable liquid at a temperature of about 26°C. Air pressure should be applied slowly up to 1½ times the maximum working pressure of the system in which the assembly is used. The pressure should be maintained for 5 minutes and the assembly checked for any signs of bubbles indicating a leak.

- NOTES:**
- 1) Water at this temperature assists in the dispersion of any air bubbles trapped under the wire braiding, but the assembly should also be agitated.
 - 2) In the case of hose assemblies with mechanically-attached end fittings, no attempt must be made to seal off a leak by further tightening of the fitting.

- c) **Pressure Test Observations.** During operation a) and b) above, the assembly should be checked for the following:
 - i) Signs of leakage.
 - ii) Tube distortion under pressure.
 - iii) Movement of the wire braiding adjacent to its attachment to the end fittings.
- d) After the assembly has been uncoupled from the test rig and allowed to remain unconfined for at least one hour, a length check should be made with reference to the length tolerances given on the appropriate drawing or in the relevant manual.

There may be a slight elongation, but if this is beyond acceptable limits, the assembly should be rejected and returned for investigation to the manufacturing organisation concerned.

- e) **Ball Test.** A ball test should be carried out as detailed in paragraph 9.5.3 a), but where this is not possible a flow test should be made in accordance with the design requirements for the particular hose.
- f) **Drying.** To avoid corrosion, assemblies which have undergone the tests mentioned in this paragraph (10.8.3) must be thoroughly dried by placing them in a forced-draught, hot-air oven for 30 minutes with the air temperature controlled at 100°C to 105°C and the longitudinal axes of the hoses in line with the air flow. However, if paraffin was used as the pressure testing medium, it is sufficient to vibrate and drain the hoses until dry.
- g) **Test Identification.** Upon completion of testing, a further identification band or tag should be affixed to the assembly bearing the date of test and the inspection stamp. It is also recommended that an appropriate reference be made in the log book or other records.

Leaflet 20-60 Installation and Maintenance of Rigid Pipes

1 Introduction

- 1.1 This Leaflet provides guidance and advice on the installation and maintenance of rigid pipes in aircraft and should be read in conjunction with the relevant manuals and the installation drawings for the aircraft concerned.
- 1.2 Guidance on the installation and maintenance of hose and hose assemblies is given in Leaflet 20-50.
- 1.3 Information on the identification marking of system pipes is given in British Standard M23, entitled 'Identification Scheme for Pipe Lines'.

2 General

- 2.1 Certain requirements are general to the installation of all types of fluid systems, e.g. the need to avoid 'U' bends, the relief of pressure which may increase as the result of a temperature rise, the isolation of fuel pipes in certain areas and the need to reduce the possibility of incorrect assembly. All these factors are taken into consideration in the design of a fluid system, but maintenance personnel should also be thoroughly acquainted with the system on which they are working and aware of the problems associated with rigid pipes and their connections, so that any necessary inspection, maintenance or repair, can be carried out in a satisfactory manner.
- 2.2 Since fluid systems vary widely in purpose and design, it is essential that any work on a particular system is carried out strictly in accordance with the relevant Maintenance Manual.

3 Installation of Rigid Pipes

3.1 Pre-installation Checks

- 3.1.1 Before a pipe assembly is fitted into an aircraft, it should be checked to establish that it is of the specified type and that there is evidence of prior inspection and testing. The inspector's stamp should normally appear adjacent to the part number.
- 3.1.2 A pipe should be inspected for damage to the pipe itself, the end fittings and the protective treatment, for correct forming of the flared ends (or correct preset on flareless couplings) and for signs of external corrosion. If damage or deformation is suspected the pipe should be pressure tested or the roundness of the bore checked (as applicable). Such checks are extremely important, since dented or otherwise damaged pipes may cause a restriction to fluid flow which could have serious consequences. Where permitted in the Maintenance Manual, light external corrosion may be blended out and the protective treatment re-applied. Internal or deep corrosion would be causes of rejection of the assembly.
- 3.1.3 Dirt, swarf, dust, etc., introduced by fitting pipes which have not been adequately cleaned, may not only affect the various services of which the pipe system forms a part, but may increase the wear of the various components in the system and thus cause a malfunction. It is of the utmost importance, therefore, that adequate precautions are taken at all times to ensure the scrupulous cleanliness of individual pipes and the complete pipe system. Prior to assembly, all pipes should be blown out with clean, dry air and, where applicable, flushed with clean, filtered fluid of the type

to be used in the particular system in which the pipes are to be installed. For pipes used in oxygen systems an additional approved degreasing process should also be used, since oil or grease in contact with oxygen under pressure may cause an explosion.

- 3.1.4 If a pipe is not to be installed immediately, its ends should be blanked following pre-installation inspection and tests, using the blanks fitted during storage or suitable alternatives. Plugs and blanks to standard specification are generally suitable for this purpose, but in instances where standard blanks cannot be fitted it must be ensured that the blank used is so made that it cannot be left in position when the pipe is installed. Rag, tape or paper should not be used for blanking purposes.

3.2 Installation

- 3.2.1 When transporting or carrying pipe assemblies, or moving them into position on the aircraft, care should be taken, particularly with long pipes of small diameter, not to damage them and to support them adequately so as to prevent distortion and kinking. Pipes should be loosely fitted into position in the supporting clamps (paragraph 3.2.2) and adjusted so that the connections meet correctly (paragraph 3.2.2). The connections should be completed, the clamps tightened and bonding attached as specified.

3.2.2 Pipe Supports

- a) Multiple pipe clamps are used to support groups of pipes running adjacent to one another. These clamps are often made of red fibre, aluminium alloy, moulded rubber, nylon or other materials. The two halves of the clamps are usually joined together by bolts, which also serve to secure them to the aircraft structure. It is important to ensure that the semi-circular recesses in each half of a clamp mate correctly, do not have sharp edges and are of the correct size for the pipes they support.
- b) In instances where packing is required between the pipes and clamps, the material used should be that specified in the relevant manual or drawing. Typical packing materials are cork sheet, tinned copper or stainless steel gauze and various types of tape or low-friction liners, but leather should not be used since it may cause corrosion of the pipes.
- c) To ensure electrical continuity, some pipe clamps are self-bonding, but in other cases the use of metal gauze between the pipes and clamp may be specified. Bonding strips which bridge pipe connections are often used and should be assembled as specified in the relevant manual or drawing.
- d) Where individual pipes require support, standard clips are usually specified and usually have a moulded rubber lining which obviates the need for packing. Where individual pipes run close together a double type of 'P' clip is often used to avoid contact between the pipes and to provide support.
- e) A minimum clearance of 6 mm (0.25 in) from fixed structure, of 18 mm (0.75 in) from control rods and rigid moving parts and of 25 mm (1.0 in) from control cables, must be maintained, otherwise vibration and movement may cause chafing. Particular care is necessary to ensure that adequate clearance is maintained between pipes and moving parts and tests should be carried out to ensure that clearance is satisfactory throughout the full range of movement of the associated part. Consideration should also be given to effects which it may not be possible to simulate, such as an increase in tyre diameter due to centrifugal force, or in width due to ageing.

3.2.3 Connection of Pipes

- a) When connecting pipes with standard brazed, flared or flareless couplings the following points should be verified:
 - i) That union nuts rotate freely and can be withdrawn from the pipe end without being impeded by bends or other obstructions.
 - ii) That all loose parts such as nipples, non-metallic glands, washers, etc., which form part of the coupling, are of the correct type and are correctly located.
 - iii) That the pipe ends align correctly with their mating parts. Pipes should never be forced into position, since this may introduce considerable stress into the connection and result in subsequent leakage or fatigue damage.
 - iv) That the pipes are not drawn into position by their union nuts, since this would impose a strain on the flare of a flared coupling or the sleeve of a flareless coupling and cause deformation of the pipe.
- b) With pipes which have the compressed rubber gland type of coupling, the pipe end must be hard against the shoulder of the recess in the union adaptor before any attempt is made to tighten the union nut.
- c) Where flexible hose is used to connect rigid pipes, it is essential that the correct type of hose is used, since some may not be compatible with the system fluid.
 - i) It should be ensured that all sharp edges have been removed from the pipe ends and that, where specified, the pipe ends have been protected against corrosion.
 - ii) A gap of 6 to 12 mm (0.25 to 0.5 in) should exist between the pipes to prevent contact when flexing occurs.
 - iii) Hose clips should be of the correct size and type and should provide an adequate degree of adjustment for subsequent tightening. Care should be taken to ensure that clips are fitted on the side of the beading remote from the pipe ends and are accessible when all other systems have been installed.
 - iv) If a hose proves difficult to assemble, it may usually be lubricated by system fluid. Care must be taken to ensure that pieces of hose are not cut or broken off during assembly and left in the pipe bore.
- d) Two spanners should always be used when tightening (or disconnecting) a pipe coupling; one to hold the sleeve or adaptor and one to turn the union nut. Overtightening should be avoided since many standard pipe couplings are made of aluminium alloy, which can easily be strained. Any special tightening techniques or tightening torque values specified in the relevant publication should be carefully observed.
- e) If lubrication of threads is specified to avoid 'pick-up', it is essential that the correct lubricant is used and that it does not enter the bore of the pipe. This is particularly important with couplings used in oxygen systems, where dry film lubricants requiring special application procedures are usually specified.

4 Tests After Installation

- 4.1 All pipes will have been pressure tested following manufacture, but it is usually necessary to carry out pressure and flow tests after installation of a pipe, to ensure that there are no leaks from the pipe and its connections and that, where essential to the correct operation of the associated system, the required flow rate is obtained.

- 4.2 Power for carrying out the tests may be provided by the aircraft engine-driven pumps or by an external test rig suitable for the system concerned. The tests should be carried out strictly in accordance with the relevant Maintenance Manual. Special note should also be taken of any precautions specified for the safety of personnel or the prevention of damage to the aircraft or its systems.
- 4.3 While the associated system is pressurised and while the services are being operated, the pipelines should be inspected for flexing or displacement to ensure that the required clearances are maintained. The pipe supports should also be checked for security of attachment and the pipes for local distortion at the clamping points.
- 4.4 Leakage from pipes in liquid systems (e.g. hydraulic systems) can usually be detected by careful visual inspection and leakage from gas systems (e.g. pneumatic systems) can usually be detected aurally or, after painting the pipes and connections with a solution of water and acid-free soap, be detected by the appearance of bubbles. If the soap solution is used it should be washed off immediately after the test.
- 4.5 If leakage from a connection is apparent, the connection may be tightened, but should not be over-tightened in an attempt to cure the leak. Leaks are often caused by solid particles at the mating faces of a joint, by misalignment of a nipple, or by damage to one of the components in the joint. Loosening and re-tightening of a coupling will often cure a leak but if it does not do so, the coupling should be disconnected and the cause of the leakage ascertained.
- 4.6 After all tests have been completed satisfactorily, it is important to ensure that any liquid which may have leaked or been spilled on the airframe structure or components, is removed. In addition to any fire hazard, aircraft liquids may also have deleterious effects on some of the alloys and compounds with which they come into contact.
- 4.7 Where the work of installing and testing a pipe is complete, the connections should, where applicable, be locked in the appropriate manner (see Leaflet 51-100).

5 Maintenance of Rigid Pipes

5.1 General

The maintenance of these components should be in accordance with the relevant Maintenance Manual, but the factors outlined in paragraphs 5.2 to 5.6 should be taken into account.

5.2 Location of Pipes

- 5.2.1 Pipes which are attached to the structure of an airframe may often be in a shielded position and will not normally be subject to accidental damage, but other pipes are located in exposed positions where they may be highly susceptible to damage or corrosion. Pipes located in a wheel bay, or attached to an undercarriage leg, could easily be damaged by stones, mud or detached rubber thrown up from the tyres or corroded by regular contact with water. In other positions pipes may be subject to abuse from carelessly performed, unrelated servicing activities. Special care must, therefore, be taken when inspecting pipes in exposed locations.
- 5.2.2 Chafing may occur under pipe clamps and clips, particularly where vibration is present. Pipes which have sharp bends and which are subject to high pressure pulsations tend to develop an oval section at the bend, which may eventually develop into a crack. The possibility of damage from both these causes should be considered when inspecting pipes in any location.

5.3 **Leaks**

The presence of a leak from a pipe connection in a liquid system will often be shown by the presence of liquid or an accumulation of dust or dirt on the outside of the pipe or connection. Leakage from a gas system may only be detected by the loss of system pressure, but the position of the leak may usually be detected as outlined in paragraph 4.4. The actions described in paragraph 4.5 should be taken to cure a leak, but if these are not effective the pipe assembly should be renewed.

5.4 **Damage**

Reference should be made to the relevant Maintenance Manual when assessing damage, since the acceptability may vary with particular materials and particular systems.

5.5 **Corrosion**

Corrosion may affect pipes of any material, particularly in exposed locations and in the areas of clips and supports, where moisture may be trapped. Corrosion products should be removed and the depth of any pits should be checked. Pipes which have corroded areas which cannot be blended out within the limits specified in the relevant Maintenance Manual should be renewed. If the corrosion can be removed satisfactorily, protective treatment should be re-applied to the affected areas.

5.6 **Rubber Hose Couplings**

5.6.1 Rubber hose couplings can be affected by expansion, contraction, vibration and heat and should be inspected regularly for deterioration and freedom from oil and grease. When couplings are removed from pipe ends it is essential that damage to the pipe be avoided; if the hose is stuck to the pipe it should be carefully cut axially with a sharp knife and peeled off.

5.6.2 Hose clips have a tendency to loosen subsequent to initial installation, due to compression of the rubber and may need to be re-tightened when they have been in service for a short period.

6 **Repair of Rigid Pipes**

6.1 Damage to rigid pipes which are outside the specified limits for acceptance damage, will usually necessitate the removal of the affected pipe and the fitting of a new or reconditioned item. However, in some cases repairs may be permitted, either by the insertion of a new portion of pipe or by the insertion of a coupling, depending on the extent of the damage. After repairs, the inspections and tests detailed in paragraph 4 should be carried out.

6.2 **Repairs using Standard Couplings**

6.2.1 These repairs will normally involve removal of the damaged pipe, since the pipe ends will have to be flared or flareless couplings fitted and will usually be applied only to straight sections of pipe. However, the addition of a pipe coupling could change the resonant frequency of that portion of pipe and this could lead to vibration and fatigue; these repairs should thus only be used when specified in the relevant Maintenance Manual.

6.2.2 A circumferential crack or deep score may be repaired by cutting out the small damaged section of pipe and inserting a union body and two connections. Care should be taken to ensure that the final length of pipe is correct and that the couplings will not foul parts of the structure when installed. The pipes should be thoroughly cleaned after preparation of the ends and pressure tested before re-installation.

- 6.2.3 If the damage is in excess of that which could be repaired as outlined in paragraph 6.2.2, the damaged portion of pipe should be cut out and a new section inserted, using two new union bodies and connections, or, if the damaged portion includes one existing end fitting, by replacing that fitting and joining the new section to the old with a union body and two connections. The precautions outlined in paragraph 6.2.2 should also be observed.

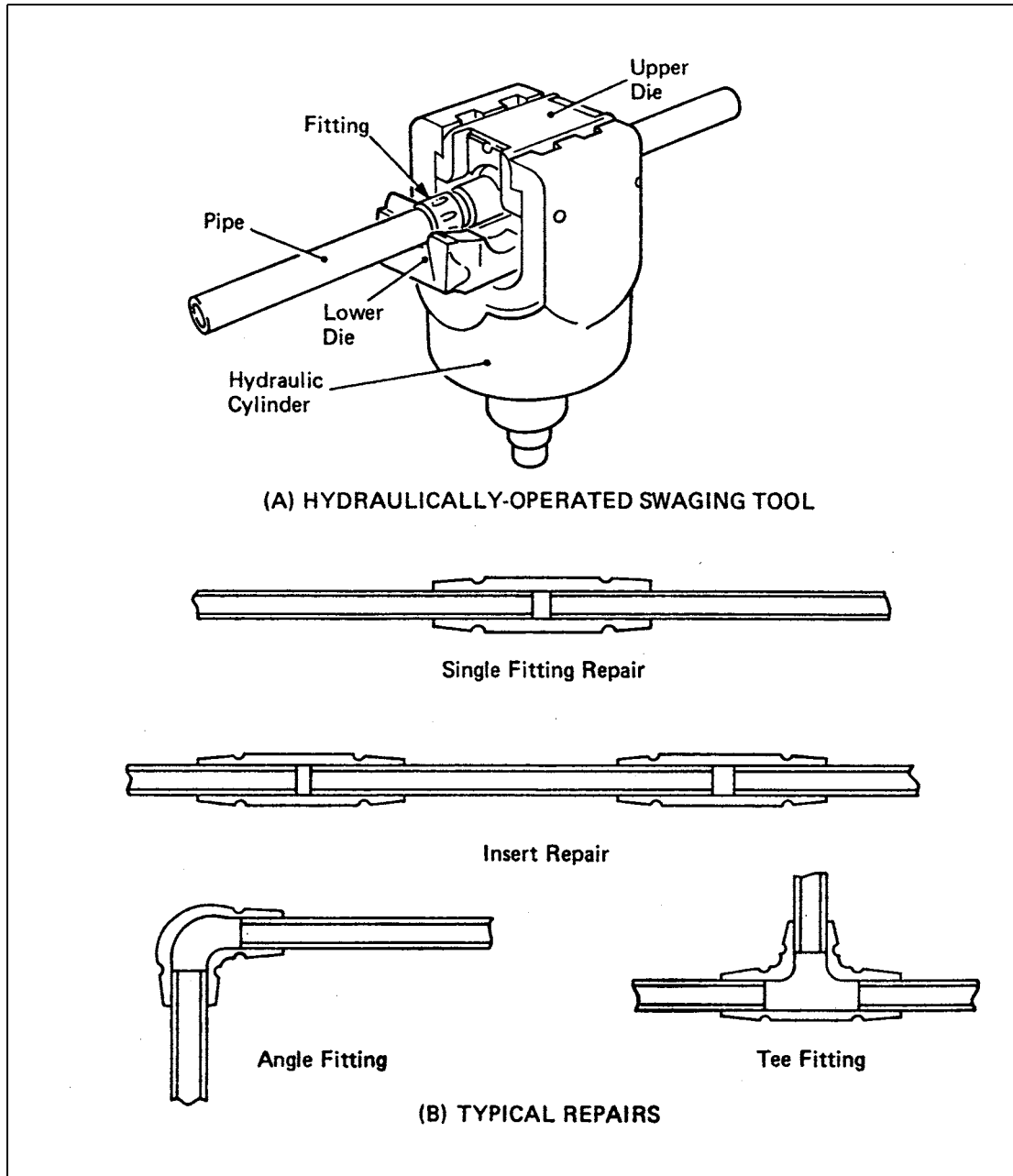

Figure 1 Tools and Typical Repairs for External Swaging Process

6.3 Repairs using Swaged Fittings

- 6.3.1 Some manufacturers specify the use of swaged fittings for carrying out in situ repairs to pipelines. Full details of the processes and of the type of swaged fittings to be used in a particular case are given in the relevant Maintenance Manual and all repairs should be carried out strictly in accordance with those instructions.

6.3.2 External Swaging Process

The damage which can be repaired by this process is broadly as outlined in paragraphs 6.2.2 and 6.2.3 and the repair consists of a tubular fitting which is swaged over a pipe joint. The gap between the pipe ends can be up to 8 mm (0.3 in), thus permitting a degree of latitude when replacing a damaged portion of pipe. Typical repairs are illustrated in Figure 1.

- a) The equipment necessary for carrying out externally swaged repairs are available covering a range of pipe diameters and comprising a hydraulically operated swaging tool with pairs of dies to cover the range of pipe diameters, a ratchet pipe cutter and a deburring tool. Various marking gauges are also provided to enable fittings to be correctly positioned and GO/NO GO gauges enable checking of the swaging operation to be carried out.
- b) The method of operation of the process is briefly as follows:
 - i) Release pipe supports sufficiently to enable the repair to be carried out.
 - ii) Select the repair kit appropriate to the pipe diameter.
 - iii) Fit and operate the ratchet cutter to remove the damaged portion of pipe.
 - iv) Using the deburring tool (which incorporates a rubber plug to prevent swarf being trapped in the pipe), remove the burrs and chamfer the pipe ends.
 - v) Clean the pipe ends, then, using the appropriate gauge, mark the pipe so that the swage fitting can be correctly located.
 - vi) Select and fit the appropriate fitting and position it over the ends of the pipes being joined.
 - vii) Select the appropriate dies, fit them to the swaging tool, position the tool over the fitting and operate the tool in accordance with the manufacturer's instructions to complete the swaging operation.
 - viii) Remove the swaging tool and dies and visually inspect the fitting for cracks. Check that the swaging operation is satisfactory by use of the GO/NO GO checking gauge provided.

6.3.3 Internal Swaging Process

The components used in this process are a male externally threaded fitting and a female fitting with either a separate or an attached union nut. This process can be used for repairing the type of damage outlined in paragraphs 6.2.2 and 6.2.3, or for repairing leaking or damaged couplings, using a special repair fitting with an extended barrel. The tools used and some typical repairs, are illustrated in Figure 2.

- a) Swaging equipment is provided for each pipe diameter and wall thickness and consists of an expander, a die set, a holding collar and a set ring for checking the expander setting.
- b) The method of operation of the process is briefly as follows:
 - i) Release the pipe supports sufficiently to enable the repair to be carried out.
 - ii) Remove the damaged portion of the pipe using a chipless cutter, then deburr the pipe ends using the tool provided. Clean the pipe ends.
 - iii) Select the appropriate tools, check the fit of the holding collar and die set and check the setting of the expander with the associated set ring.

- iv) Position the pipe in the fitting and ensure that it butts against the fitting shoulder. Mark the pipe at the end of the fitting for future reference (see 6.3.3 b) ix)).
- v) Insert the expander into the pipe with the mandrel retracted and place the assembly in one die half. Push in the mandrel until it stops, then rotate it until finger tight.
- vi) Fit the other die half and secure with the holding collar.
- vii) Rotate the mandrel with a wrench or rotary tool until the mandrel contacts the stop sleeve, then rotate it a further 10 turns to complete the swaging operation.
- viii) Loosen the mandrel and remove the swaging tools from the pipe.
- ix) Visually inspect the fitting for damage and check the marking on the pipe to ensure that the fitting is correctly positioned. Measure the internal diameter of the swaged portion of the pipe to ensure that it is within the tolerance specified in the relevant manual.

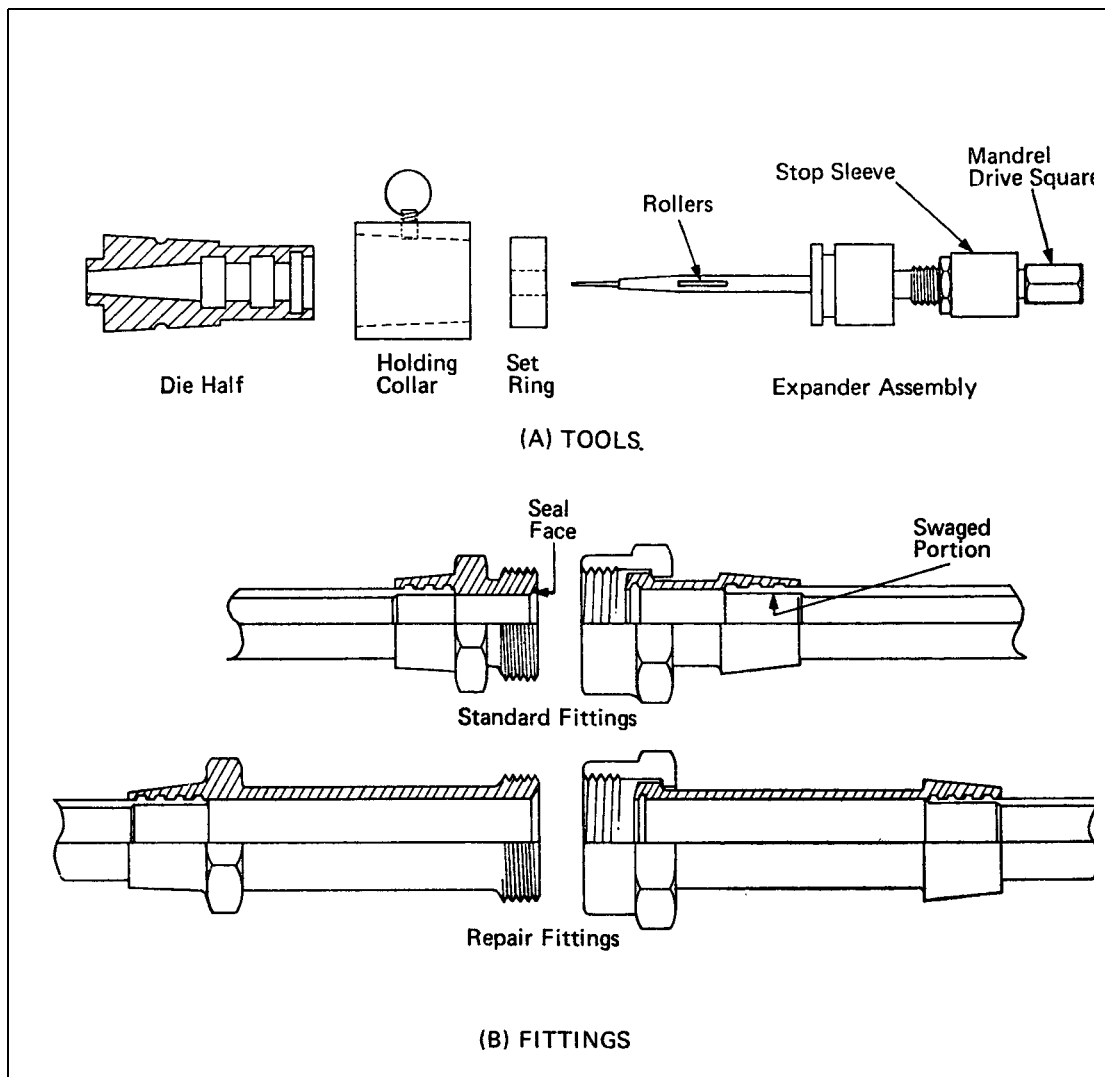

Figure 2 Tools and Typical Repairs for Internal Swaging Process

Leaflet 20-70 High Pressure Pneumatic System

1 Introduction

- 1.1 This Leaflet gives guidance on the operation and maintenance of high-pressure pneumatic systems in aircraft, and no attempt is made to describe any particular system in detail. Any maintenance work on an aircraft or system should be carried out in accordance with the procedures defined by the manufacturer, and the Leaflet should, therefore, be read in conjunction with the relevant manuals for the aircraft concerned.
- 1.2 Information on associated subjects will be found in Leaflets 20-60 - Installation and Maintenance of Rigid Pipes, 20-10 - Torque Loading, B-180 Appendix 20-4 - Maintenance and Re-Installation of Pipes and Cable Looms, and 32-20 - Wheels and Brakes.

2 General

The use of a compressed-air system to operate an aircraft's services usually represents a saving in weight compared to a hydraulic system, since the operating medium is freely available, no return lines are necessary, and pipes can be of smaller diameter. Systems having operating pressures of up to 24 MN/ml (3,500 lbf/in²) are in use, and provide for the rapid operation of services when this is required. However, compressed air is generally not suitable for the operation of large capacity components, leaks can be difficult to trace, and the results of pipeline or component failure can be very serious.

- 2.1 Extensive high-pressure pneumatic systems powered by engine-driven compressors are generally fitted on the older types of piston-engined aircraft and are used to operate services such as the landing gear, wing flaps, wheel brakes, radiator shutters and, at reduced pressure, de-icing shoes. There are some modern aircraft which also use a high-pressure pneumatic system and there are many aircraft which use pneumatic power for the emergency operation of essential services; the latter type of system is usually designed for ground-charging only.
- 2.2 Low-pressure pneumatic systems used on most turbine-engined aircraft for engine starting, de-icing, and cabin pressurization, are supplied with compressed air tapped from the engine compressor and are not dealt with in this Leaflet.

3 Typical System

This paragraph describes both a typical high-pressure pneumatic system, and the types of components which could be used.

- 3.1 The system illustrated in Figure 1 contains two separate power circuits, each of which is supplied by a four-stage compressor driven from the gearbox of one main engine, and a common delivery pipe to the high-pressure storage bottles and system services. A multi-stage cooler attached to each compressor cools the air between each of the compression stages, and a means is provided for off-loading the compressor when the system is not being used.

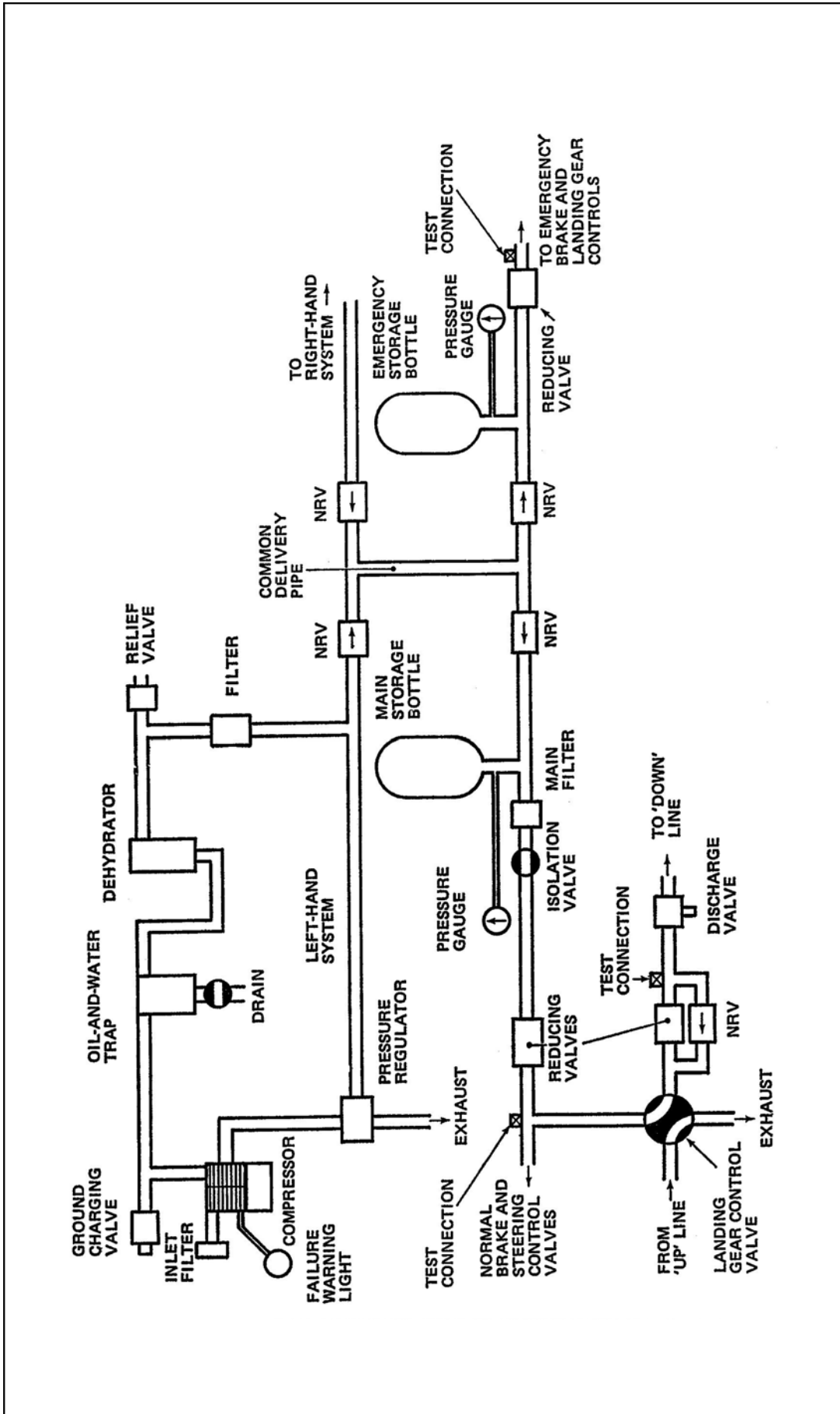

Figure 1 Typical High-Pressure Pneumatic System

- 3.2 Air is drawn through an inlet filter into each compressor, and is discharged through an oil-and-water trap, a chemical dehydrator, a filter and a non-return valve, to the main storage bottle and system. Overall control of main system pressure is provided by means of a pressure regulator, but pressure relief valves are included to prevent excessive pressures in the system, which may be caused by regulator failure or by an increase in temperature in the pipelines and components. Pressure reducing valves are used to reduce the pressure supplied to some components.
- 3.3 A storage bottle for the emergency system is pressurized through a non-return valve from the main system supply, and maintains an adequate supply of compressed air to enable the landing gear and flaps to be lowered, and the brakes to be applied a sufficient number of times to ensure a safe landing.
- 3.4 Isolation valves are fitted to enable servicing and maintenance to be carried out without the need to release all air from the system, and pressure gauges are provided to indicate the air pressure in the main and emergency storage bottles.

4 Components

The types of components used in a high-pressure pneumatic system will vary considerably between aircraft, but the examples considered in this paragraph are typical of the components which may be found in current use.

- 4.1 **Compressors.** A positive-displacement pump is necessary to raise the air pressure sufficiently for the operation of a pneumatic system, and a piston-type pump is generally used. Some older types of aircraft are fitted with a single-cylinder piston pump, which provides two stages of compression and raises the working pressure to approximately 3 MN/ml (450 lbf/in²). To obtain higher working pressures further compression stages are required. The compressor described in paragraphs 4.1.1 to 4.1.3 is capable of raising air pressure in four compression stages to 24 MN/ml (3,500 lbf/in²).
- 4.1.1 The compressor illustrated in Figure 2 has two stepped cylinders, each of which houses a stepped piston; a plunger attached to the head of No. 2 piston operates in a small cylinder bored in the head of No. 2 cylinder. The reciprocating motion of the main pistons is provided by individual cranks and connecting rods, the cranks being rotated by a common drive gear, and rotating in the same direction. Air passing between each compression stage is routed through an integral cooler, and lubrication is provided by an oil feed connection from the main engine lubrication system.
- 4.1.2 Compression depends on the volume of each successive stroke being smaller than the stroke preceding it; the induction strokes for each cylinder and the four compression strokes are accomplished during each revolution of the cranks. Operation of the compressor is as follows:
- On the downward stroke of No. 1 piston, air is drawn into the cylinder head through a filter and Non-Return Valve (NRV).
 - On the upward stroke of No. 1 piston, air is compressed in the cylinder, opens a NRV in the cylinder head, and passes to the annular space formed between the steps of the cylinder and piston.
 - The next downward stroke of No. 1 piston compresses air in the annular space in this cylinder and forces it through a NRV into the annular space formed between the steps of No. 2 cylinder and piston. No. 2 piston is approximately 90° in advance of No. 1 piston, and is moving upwards as No. 1 piston approaches the bottom of its stroke.

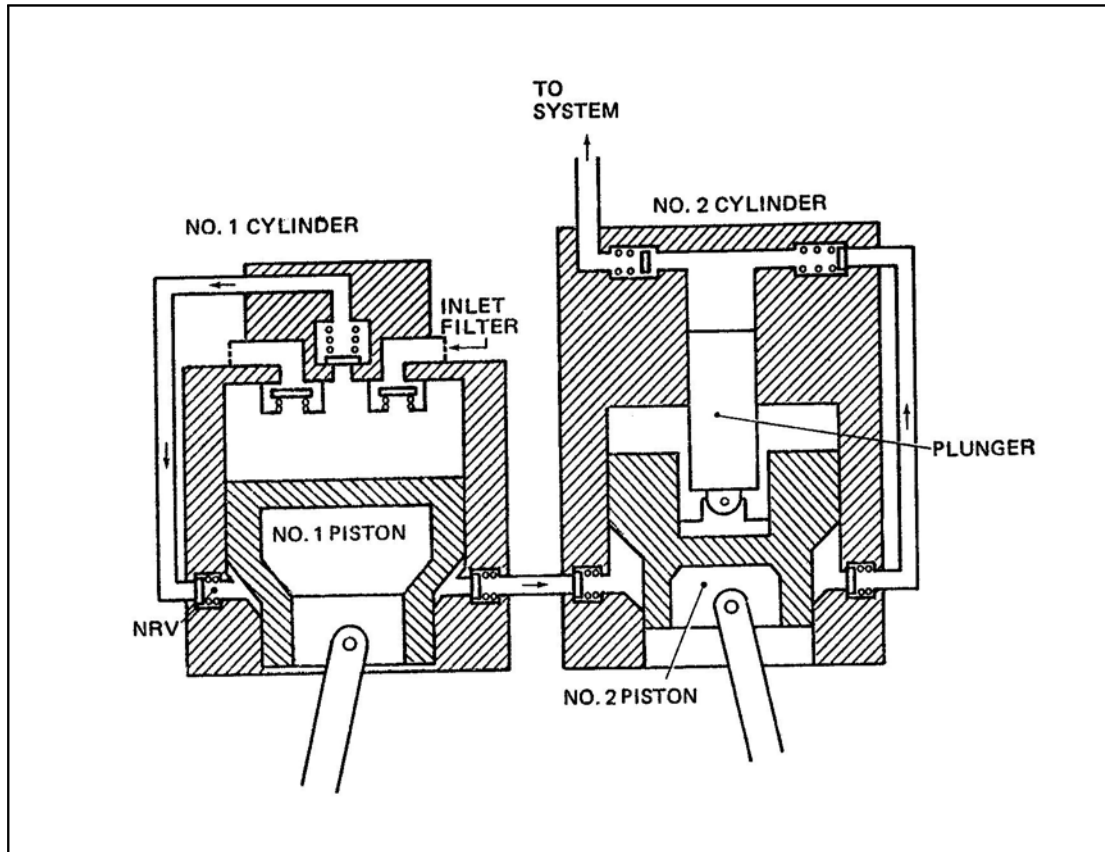

Figure 2 Air Compressor

- d) On the downward stroke of No. 2 piston, air is compressed in the annular space at the bottom of the cylinder, and passes through a NRV into the small cylinder formed in No. 2 cylinder head.
- e) On the upward stroke of No. 2 piston, the plunger attached to it also moves upwards, further compressing the air in the small cylinder and passing it through a NRV to the system.

4.1.3 A pressure warning transmitter is fitted at the second-stage outlet, and third-stage pressure is connected to the pressure regulator (paragraph 4.2).

4.2 **Pressure Regulator.** The pressure regulator is fitted to control the maximum pressure in the system and to off-load the compressor when the system is idle. With the regulator illustrated in Figure 3, system pressure is fed to the top connection and acts on a piston, the lower end of which is in contact with the ball of a spring-loaded ball valve. At the predetermined maximum system pressure, the air pressure on the piston overcomes spring pressure and the ball valve is opened, releasing third-stage compressor pressure to atmosphere and allowing the pump to operate at second-stage pressure only. If any pneumatic services are operated, or a leak exists in the system, the air pressure trapped in the storage bottle and pipelines will drop, and the ball valve in the pressure regulator will close. The compressor will thus be brought back on line until the maximum system pressure is restored.

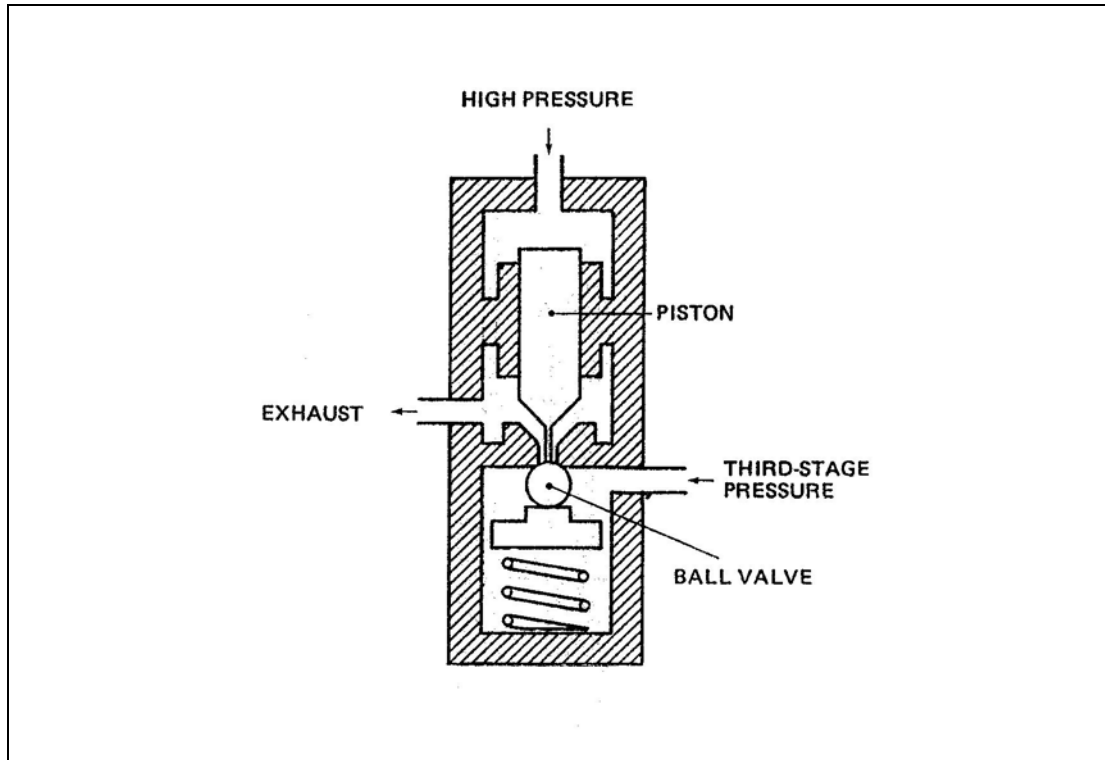

Figure 3 Pressure Regulator

- 4.3 **Oil-and-Water Trap.** The oil-and-water trap is designed to remove any oil or water which may be suspended in the air delivered by the compressor. It consists of a casing with inlet and outlet connections at the top and a drain valve in the bottom. Air entering the trap does so through a stack pipe, which includes a restriction and a baffle to prevent the air flow stirring up any liquid or sediment in the bottom of the container. Air leaving the trap also passes through a stack pipe, to prevent liquid or sediment entering the system during aircraft manoeuvres.
- 4.4 **Dehydrator.** To protect pneumatic systems from malfunctioning due to moisture freezing in the components and pipelines, the compressed air may be dehydrated by a substance such as activated alumina, or it may be inhibited by a small quantity of methanol vapour. The handling of methanol presents some difficulties, however, and because of its corrosive nature systems must be specially designed for its use; activated alumina is, therefore, more generally used.
- 4.4.1 Activated alumina is housed in a container through which the compressed air passes after leaving the oil-and-water trap, and which generally contains a filter at the outlet end. The charge of alumina in the container will gradually become saturated with moisture, and should be changed at the specified intervals. The number of flying hours at which the alumina charge is changed is normally determined by the aircraft manufacturer through practical experience.
- 4.5 **Storage Bottles.** In a pneumatic system the storage bottles provide the reservoir of compressed air which operates all services, the compressors being used to build up system pressure when it falls below the normal level. The volume of the actuators and pipelines determines the size of the bottles required for the normal and emergency operation of the pneumatic services.
- 4.5.1 Storage bottles are generally made of steel, and may be of wire-wound manufacture for maximum strength. Bottles are generally mounted in an upright position, and a

fitting screwed into the bottom end contains the supply connection and, usually, a connection to an associated pressure gauge, together with a drain valve by means of which any moisture or sediment may be removed. Stack pipes are provided at the supply and gauge connections in the fitting, to prevent contamination passing to the system or pressure gauge. Pressure testing of high-pressure storage bottles is required at specified periods, and the date of testing is usually stamped on the neck of the bottle.

4.6 **Pressure Reducing Valves.** Some services operate at pressures lower than the pressure available in the air bottle, and are supplied through a pressure reducing valve. This low pressure is, in some instances, further reduced for the operation of, for example, the wheel brakes, by the fitting of a second pressure reducing valve.

4.6.1 Figure 4 illustrates the operation of a pressure reducing valve. When pressure in the low-pressure system is below the valve setting, the compression spring extends and, by the action of the bell-crank mechanism, moves the inlet valve plunger to admit air from the high-pressure system. As pressure in the low-pressure system increases, the bellows compresses the spring and returns the inlet valve plunger to the closed position. The inside of the bellows is vented to atmosphere, and the valve thus maintains a constant difference in pressure between the low-pressure system and atmospheric pressure.

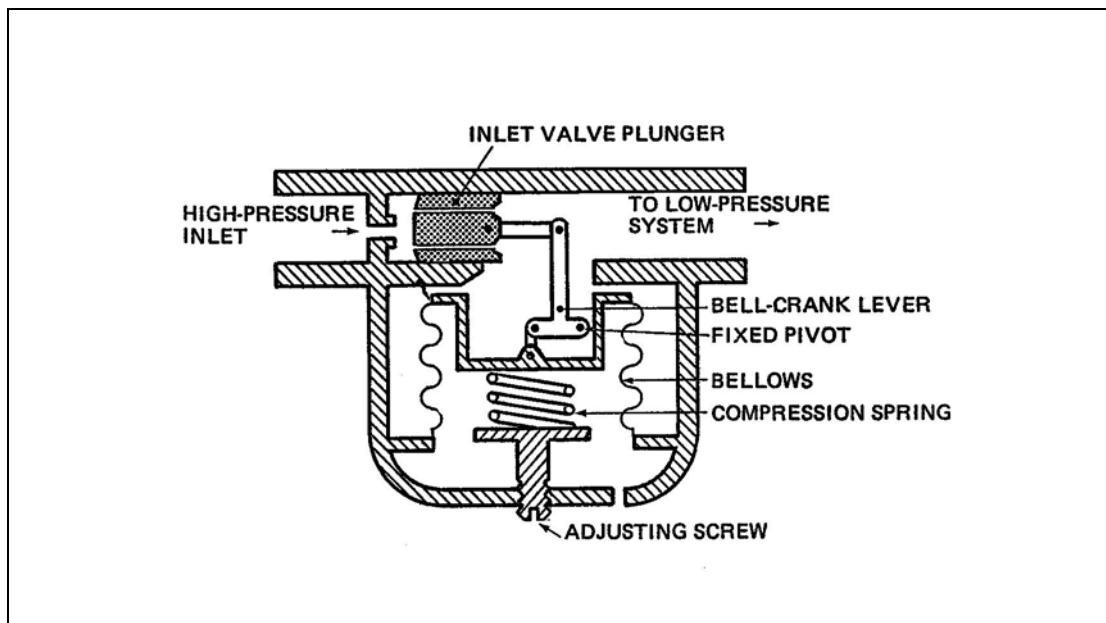

Figure 4 Pressure Reducing Valve

4.7 **Pressure Maintaining Valve.** A pressure maintaining valve is designed to conserve air pressure for the operation of essential services (e.g. gear extension and wheel brake operation), in the event of the pneumatic system pressure falling below a pre-determined value.

4.7.1 Figure 5 illustrates the operation of a typical pressure maintaining valve. Under normal circumstances air pressure is sufficient to open the valve against spring pressure and allow air to flow to the non-essential services. Should the pressure in the storage bottle fall below a value pre-set by the valve spring, however, the valve will close (as shown) and prevent air passing to the non-essential services.

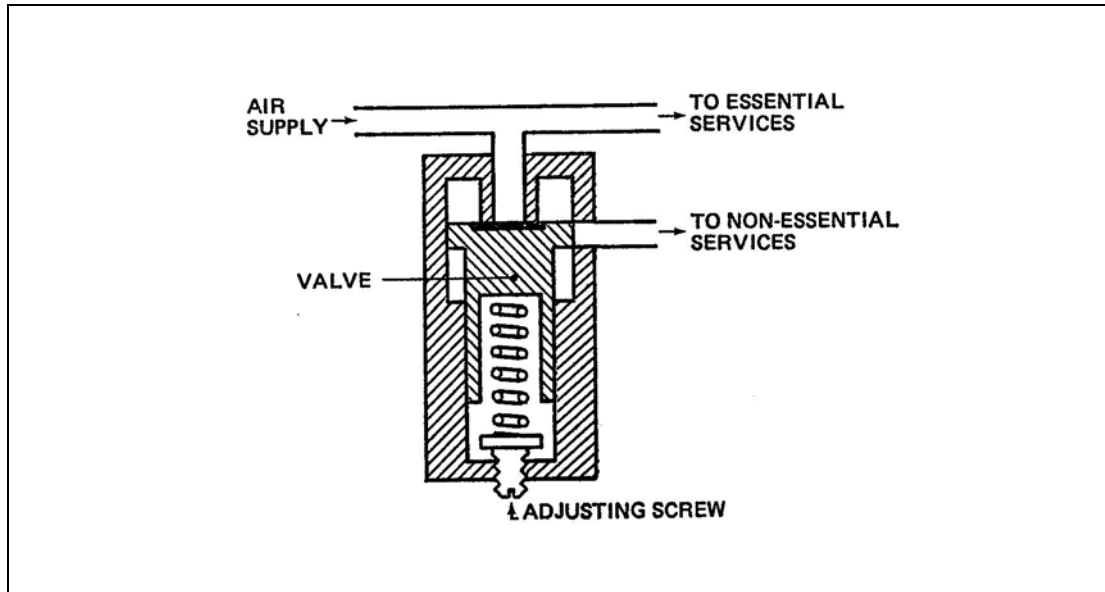

Figure 5 Pressure Maintaining Valve

- 4.8 **Control Valves.** Compressed air stored in the bottle is distributed to the various pneumatic services, and directed to the various types of actuators by means of control valves, which may be manually or electrically operated. Examples of several types of control valves are described in paragraphs 4.8.1 to 4.8.3.
- 4.8.1 **Electrically-operated Control Valve.** The electrically-operated control valve for a pneumatic landing gear retraction system is illustrated in Figure 6. Selection of the landing gear position is made by either of two push-buttons (marked 'up' and 'down') which are mechanically interconnected to prevent operation of both buttons at the same time. These buttons, when depressed, supply electrical power to the 'up' or 'down' solenoid as appropriate. Actuation of this solenoid lifts an attached pilot valve, supplying compressed air to the cylinder at the bottom of the associated valve; the piston moves downwards, and the valve guide attached to it opens the inlet valve, admitting compressed air to the appropriate side of the landing gear actuators. At the same time the beam attached to the extension of this piston transfers movement to the valve guide in the opposite valve, allowing air from the opposite side of the actuators to exhaust to atmosphere.
- 4.8.2 **Manually-operated Control Valve.** The valve illustrated in Figure 7 is a simple two-position valve, and may be used as an isolation valve in some systems. The sleeve valve is operated by a cam, and is spring-loaded to the 'opposition; linkage from the cam spindle connects the valve to an operating lever. When used as an isolation valve the operating lever would normally be wire-locked in the 'on' position, and would only be used to permit servicing operations to be carried out.

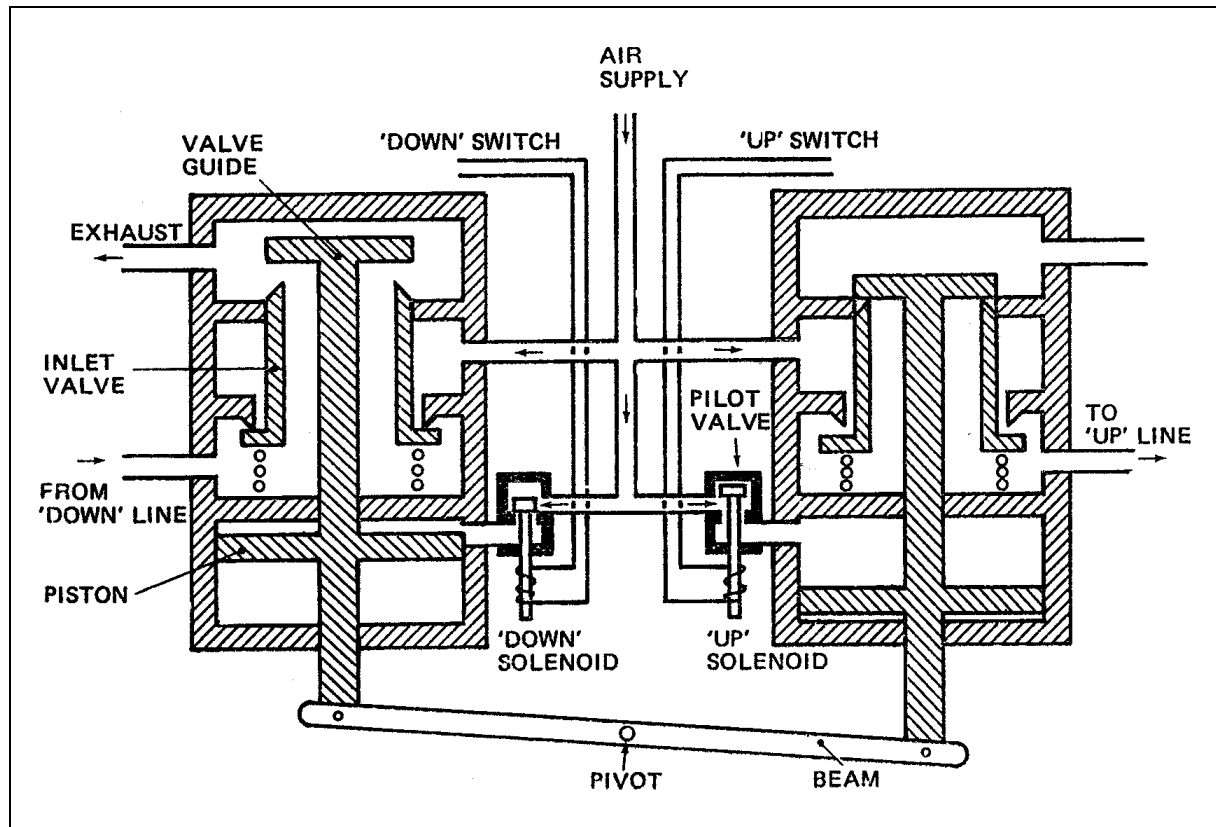

Figure 6 Electrically-Operated Control Valve

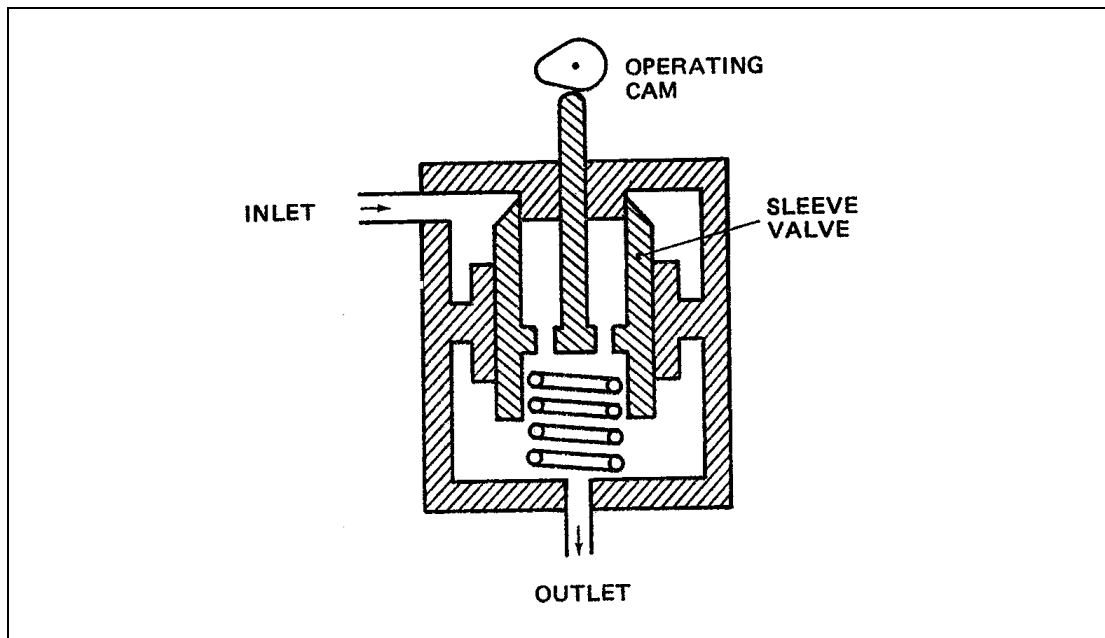

Figure 7 Manually-Operated Control Valve

- 4.8.3 **Brake Control Valve.** Some older types of aircraft may be fitted with a type of brake control valve (known as a dual-relay valve) by means of which total brake pressure is applied by the operation of a single hand-control, and distribution to either or both brakes is effected by means of a mechanical connection to the rudder bar. The type of brake control valve illustrated in Figure 8 is used on some modern aircraft, and

is operated by linkage from brake pedals attached to the rudder bar; separate valves supply compressed air to the brake units on each wheel. Operation of the valve is as follows:

- a) In the 'off' position (as illustrated) the inlet valve is closed and pressure in the brake line is connected to the exhaust port.
- b) Pressure applied to the associated brake pedal is transmitted via the brake linkage to the valve sleeve, which moves up to close the exhaust valve. Further pressure applied through the valve sleeve and lower spring tends to open the inlet valve, and air pressure in the brake line combined with the force exerted by the upper and centre springs tends to close it. This produces a balanced condition in which any increase in the force applied to the valve sleeve results in a higher air pressure in the brake line, and a decrease in the force applied to the valve sleeve results in opening of the exhaust valve and a reduction in the air pressure in the brake line.

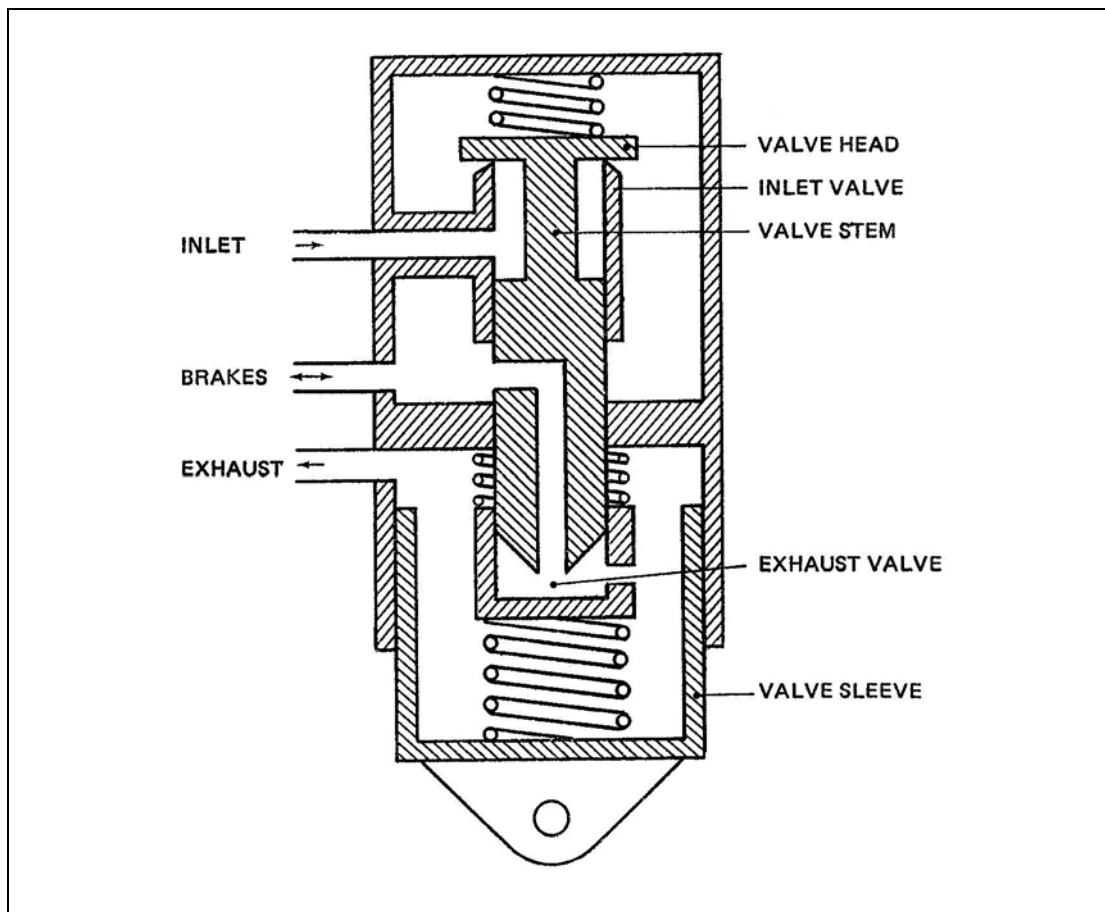

Figure 8 Brake Control Valve

- 4.9 **Actuators.** The purpose of an actuator is to transform the energy of the compressed air into linear or rotary motion. Actuators in pneumatic systems are normally of the linear type. Because of the nature of the operating medium, actuators in pneumatic systems are often damped to prevent violent operation of the services. A typical damped actuator is illustrated in Figure 9, the damping in this case being obtained by forcing grease through the annular space between the inner wall of the piston rod and a stationary damper piston; an orifice and plate valve in the damper piston provide less damping action when the piston rod retracts than when it extends. This type of actuator could be used, for example, to operate the landing gear and to restrict the rate of extension.

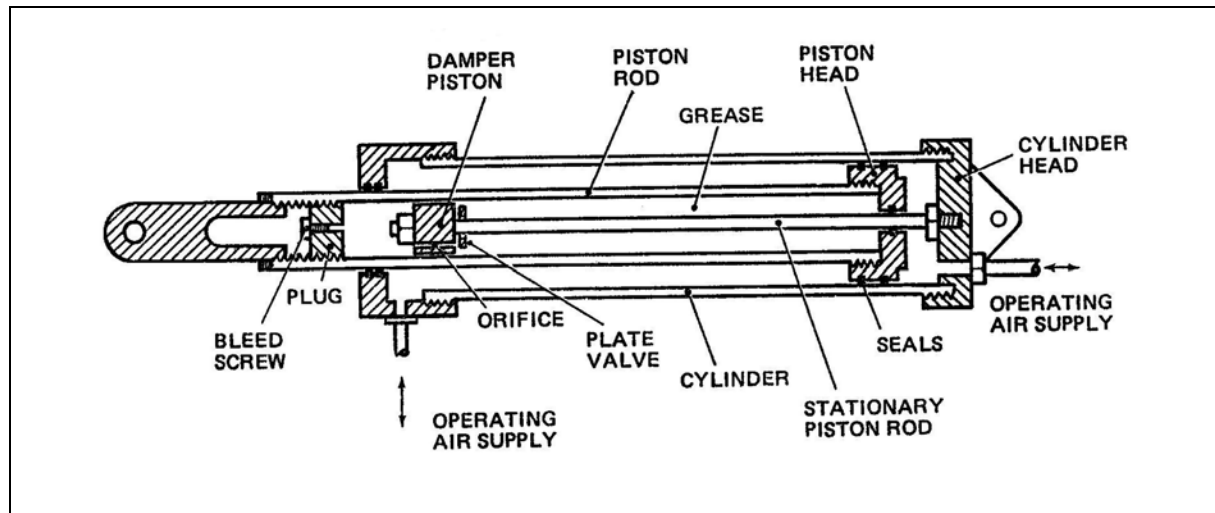

Figure 9 Damped Actuator

5 Removal and Installation

Aircraft pneumatic installations vary considerably, and reference should be made to the relevant Maintenance Manual before any work is carried out on a particular aircraft. Failure to observe any precautions detailed by the manufacturer could result in damage to the aircraft and, possibly, in physical injury. High pressures exist in parts of the system even when the aircraft engines are not running, and this pressure must be released before attempting to disconnect or remove any components or pipelines. Rapid operation of the system services is also a feature of pneumatic systems, and care must be taken during any tests to ensure that the services have complete freedom of movement and that the area is clear of personnel.

- 5.1 **Cleanliness.** The cleanliness of a pneumatic system is of the utmost importance to its correct operation. The filters fitted in the system will, if serviced at the appropriate intervals, protect the system components from contamination during normal use, but whenever a connection is broken or components are removed, the open pipes should be blanked immediately to prevent the entry of dirt and moisture; blanks should be left in position until the component is re-installed or the connection is re-made. Proper blanking caps should be fitted wherever possible, and on no account should rags or masking tape be used. Any external rig which is likely to be used to charge an aircraft system must be kept to the same standards of cleanliness, and the supply line should be blown through before being connected to the aircraft charging point.
- 5.2 **Removal of Components.** Before removing any components or disconnecting any pipelines, all pressure should be released from that part of the system. In some cases release of all pressure from the storage bottle will be specified by the manufacturer as being necessary; in the typical system shown in Figure 1 this is done by operating the discharge valve, but in other systems it may be necessary to unscrew a connection a quarter turn to release the air. Even those parts of the system protected from storage bottle pressure by a non-return valve or isolation valve may retain sufficient residual pressure to cause damage, and pipe connections should, therefore, be unscrewed slowly, pausing after the first quarter turn of the union nut to ensure that air pressure escapes slowly.
- 5.2.1 On aircraft which have a pneumatically-operated landing gear retraction system, ground locks should be fitted before releasing air from the 'down' lines in the system,

- and the landing gear control lever and emergency landing gear selector should be labelled to ensure that they are not operated.
- 5.2.2 On systems which have electrically-operated control valves it will usually be necessary to electrically isolate the part of the system being worked on, and this may be done by tripping the associated circuit-breakers or removing the associated fuses. Electrical isolation and placarding of controls is advisable in order to avoid any possible inadvertent selection, whether or not power is available at the time. Note should be taken of the disconnected circuits for reference when re-assembling.
- 5.2.3 Where a component, such as the compressor, has to be removed because of mechanical failure, other parts of the system may have become contaminated by metal particles. Filters downstream of the component which has failed should be checked for contamination, and if this is found, all components and pipes which may have been affected should be removed and cleaned or renewed as necessary.
- 5.2.4 Immediately after removing a component all openings should be blanked; flexible pipes should be secured to adjacent structure to prevent them from becoming damaged.
- 5.3 **Installation.** Before installing a new component, it should be inspected for any damage which may have occurred during storage, the part number and modification state should be checked, and it should be ensured that the storage life (paragraph 7) has not been exceeded. The thorough testing of components drawn from stores is not normally required (paragraph 5.4), but it should be ascertained that external moving parts function without binding, and operate in the correct sense. Components which have been removed from an aircraft and are to be re-installed must be thoroughly examined for cleanliness; pipes should be blown through with clean, dry air.
- 5.3.1 New gaskets should be fitted to all components which require their use, and other protective material such as may be used under straps or clamps, should be inspected for condition before being refitted.
- 5.3.2 Some components, such as non-return valves, must be fitted the correct way for the system to operate as intended, and are usually designed with different types of fittings at each connection to prevent incorrect installation. In some cases, however, the fittings may be identical, and the direction of flow marked on the component, should be checked.
- 5.3.3 The male threads on connections should be sparingly lubricated before assembly, as recommended by the manufacturer, and union nuts should be fitted by hand so as to check that the threads are not binding and to ensure that the connections are correctly aligned. AU union nuts should be tightened to the torque values specified in the relevant Maintenance Manual, and should be locked in the appropriate manner.
- 5.3.4 All blanks should be removed from pipes before installation, and it should be ensured that the pipes are correctly installed and free from acute bends and kinks or damaged protective covering, are correctly aligned with mating connections, have adequate clearance between adjacent pipes and structure, and have been correctly identified, locked and supported. Flexible pipes should be checked to ensure that they are not bent, twisted or stretched at the limits of movement of the component to which they are attached, and are adequately supported.
- 5.3.5 After the installation of a component, any mechanical or electrical connections should be made, and a full functioning test should be carried out.
- a) Mechanical controls should be connected and adjusted so that control lever movement and valve operation are synchronized, and if stops are fitted to the valve

the control should be adjusted to ensure that these stops are contacted; full details concerning the rigging and adjustment of the controls for a particular system should be obtained from the relevant Maintenance Manual. Controls should be free from binding over their full range of movement, and should have at least the minimum specified clearance from adjacent structure. After adjustment and checking, all linkage should be locked and lubricated as appropriate.

- b) The circuits to electrically-operated control valves should be checked for correct installation and functioning. Micro-switches should be adjusted carefully to ensure that they operate positively without the plunger bottoming, and their mountings should be checked for rigidity and security.
- c) Unless otherwise stated, an actuator should be adjusted so that its piston does not bottom in its cylinder at the ends of its travel, and it should be checked for smooth and correct operation. When required by the relevant Maintenance Manual, actuators should be filled with grease or other specified damping fluid before carrying out a functional check.

5.4 **Testing.** The overhaul and testing of individual components must be carried out in accordance with the manufacturer's Overhaul Manual and requires the use of specially designed test rigs to ensure their correct operation. Dismantling of components should not be undertaken unless suitable test facilities are available, and the aircraft system should not be considered to be an acceptable alternative. Once tested after manufacture or overhaul, components do not normally require further tests to be carried out prior to installation, provided that their storage life has not been exceeded and that there is no superficial damage. System tests should, however, be carried out on new installations, after any part of a system has been adjusted, dismantled, or renewed, and at the periods specified in the relevant Maintenance Schedule. The method of carrying out a test of the pneumatic system is detailed in the aircraft Maintenance Manual, and will normally include the operations outlined in paragraphs 5.4.1 to 5.4.5.

- 5.4.1 After a system has been exhausted of air pressure, or parts of a system have been isolated from the storage bottles to permit removal and installation of components, certain precautions must be taken to prevent damage to the aircraft or injury to personnel when the system is re-pressurized prior to testing. The electrical circuits to electrically-operated controls should be reinstated by resetting the appropriate circuit breakers or refitting the fuses, and the positions of all controls, including emergency controls, should be checked as corresponding to the positions of the actuators in the pneumatic services. Ground locks should be fitted to the landing gear (unless the aircraft is on jacks), and air pressure should be built up slowly in the relevant parts of the system, either through the charging connection or by opening the isolation valves, as appropriate.
- 5.4.2 When a compressor has been changed, or whenever a slow build-up in system pressure has been reported, the output of the compressors should be checked; this check is usually carried out by running the appropriate engine(s) on the ground. The engine power setting, initial pressure, and maximum time permitted to build up pressure by a specific amount, are usually quoted in tables provided in the relevant Maintenance Manual; separate tables are often provided for checking new and in-service compressors.
- 5.4.3 When checking the operation of the various control valves in the system, care should be taken to ensure that the associated services are free to function and that adequate clearance is provided between any moving part and adjacent structure, trestles, etc. The air exhausted from some large components may be capable of causing damage, and warning notices should be positioned before operating these particular services.

- 5.4.4 The adjustment and correct operation of all locks, actuators, selectors, control mechanisms and indicators should be checked, using the appropriate test connections where necessary, and the operating pressures of the regulators, pressure reducing valves, pressure maintaining valves, brake valves and relief valves should be verified. It should also be ascertained that there is no internal or external air leakage from the valves or connections.
- 5.4.5 AU services should be checked for correct operation, smoothness, and, when specified, speed of operation and system pressure drop. These tests should be carried out using both the normal and the emergency systems, and should be repeated a sufficient number of times to ensure consistency.

6 Maintenance

Maintenance of the pneumatic system should be carried out in accordance with the relevant Maintenance Manual and Schedule, and should include replenishment from an external source as necessary, routine inspections for condition, cleaning of filters, replacement of desiccants and checking for leaks.

- 6.1 **Chaffing.** A pneumatic system is fitted with one or more charging valves, by means of which the system may be fully pressurized from an external source. These valves also act as, or include, a non-return valve, and are fitted with a dust cap which must be removed when connecting an external supply. Any external supply, whether from high-pressure storage bottles or a mobile compressor, must be fitted with oil-and-water traps, and, preferably, a dehydrator, to ensure that the air supplied is clean and dry. The supply hose should be capped when not in use, and should be blown through with compressed air before being connected to the charging valve, to prevent the introduction of moisture or dirt into the aircraft system. Care should be taken to turn off the external supply and to release air pressure from the supply hose before disconnecting it from the aircraft.
- 6.2 **Routine Inspection.** The scheduled routine servicing of the pneumatic system should include the following operations:
- 6.2.1 **Filters.** Wire-gauze air and oil filters such as may be fitted to a compressor, should be removed for cleaning and inspection at frequent intervals; cleaning in solvent is usually recommended, and the filters should be dried thoroughly before being refitted. The main air filter usually has a paper or felt element, and this should be renewed at the specified periods. This filter should also be drained periodically in order to check for the presence of water or oil, and this is best carried out by unscrewing the drain plug a quarter turn and releasing the trapped air; if moisture is found, the filter housing should be thoroughly dried and the element renewed, and if oil is found the compressor and the oil-and-water trap should be examined. A porous metal filter may also be fitted in some systems, and this is usually cleaned by reverse-flushing with methylated spirits; the filter must be thoroughly dried before replacing it in the system.
- 6.2.2 **Physical Condition.** All components and pipelines in the system should be examined periodically, for corrosion, cracks, dents and other superficial damage. Minor damage may often be removed and the area re-protected, but some components (e.g. storage bottles) must be considered unserviceable if the damage extends beyond the protective treatments. The components should also be checked for security and locking, and the pipelines for satisfactory clamping, protection and identification. Any leaks found should be treated as outlined in paragraph 6.3.

- 6.2.3 **Storage Bottles.** Storage bottles should be drained periodically to remove any sediment or moisture which may have accumulated. Draining is best carried out with pressure in the system, but the drain plug should not be unscrewed more than a quarter turn; without pressure in the bottle the drain plug may be completely removed, and it may be necessary to use a thin rod to clear any congealed sediment. After draining, the drain plug should be tightened to the specified torque and re-locked. The pressure testing of storage bottles should be carried out in accordance with, and at the times specified in, the relevant manuals.
- 6.2.4 **Oil-and-Water Trap.** The oil-and-water trap should be drained daily, or after each flight if freezing conditions exist, to prevent the freezing of water in the pipe from the compressor. Draining should be carried out as soon as possible after flight, and the procedures outlined in paragraph 6.2.3 for storage bottles should be used.
- 6.2.5 **Dehydrator.** The periods at which the alumina charge or other desiccant should be changed, depend on the weather conditions in general, and may vary considerably; the actual periods should be determined by experience, and should be such that the dehydrating agent never becomes saturated with moisture. In many cases it will be necessary to remove the dehydrator in order to recharge it, and the following procedure should be used:-
- Remove residual pressure from the container by means of the drain plug on the oil-and-water trap.
 - Disconnect the pipe connection on the container, release the securing strap, and remove the container from the aircraft.
 - Unscrew the end cap from the container and remove the dehydrating agent.
 - Remove any moisture from the container by passing warm, dry air through it, and clean the outlet filter in methylated spirit. Check the container for corrosion.
 - Examine any seats for damage or deterioration, and renew as necessary.
 - Fill the container with a fresh charge of dehydrating agent, then refit and lock the end cap.
 - Refit the container in the aircraft, and tighten and lock the connections and securing strap.
- NOTE:** The dehydrating agent is normally delivered in air-tight tins, but if permitted by the manufacturer the old charge may be re-activated, in emergency, by heating to 250°C to 300°C for 4 to 5 hours.
- 6.2.6 **Lubrication.** Any linkage associated with the control levers and valves in the pneumatic system, should be lubricated in accordance with the relevant Maintenance Manual, at the periods specified in the Maintenance Schedule. Engine oil is generally satisfactory for use on the threads of fasteners and components, but silicone grease may be recommended for use on some, components (e.g. the dehydrator end cap), where it may come into contact with rubber seals.
- 6.2.7 **System Operation.** The operation of the complete system should be checked at the intervals specified in the Maintenance Schedule, whenever components are changed, and whenever faulty operation is reported. The method of testing a system is specified in the relevant Maintenance Manual, and the operations which are usually included are outlined in paragraph 5.4.
- 6.3 **Leakage.** In high-pressure pneumatic systems some leakage will inevitably occur, and manufacturers usually lay down a maximum permissible leakage rate for a particular aircraft system. Leakage will sometimes become apparent through the slow or incorrect operation of a service, or failure to maintain system pressure, but a

small leakage may only be noticed by a drop in system pressure when the aircraft is out of use for a short period (e.g. overnight). The leakage rate is checked by fully pressurizing the system, then re-checking the pressure after a period of 12 hours (or other specified time). The initial and final pressures should be recorded, taking into account the ambient temperature at the time; if this drop exceeds the maximum permitted, a check for leaks should be carried out.

6.3.1 **Checking for Leaks.** Large external leaks can often be traced aurally or by the application of a non-corrosive soapy water solution (bubbles will appear at the position of a leak); all traces of soap solution must be removed after the test, using plenty of clean water, and the parts must be thoroughly dried. Smaller external leaks may not be detectable by these methods, but several types of electronic leak detectors are available which can be used to detect even the smallest leak. These detectors usually operate on ultrasonic principles, or by measurement of the positive ions emitted from the leak after a small quantity of carbon tetrachloride has been introduced into the system; operation of these detectors should be in accordance with the manufacturer's instructions. Internal leakage may be difficult to trace, and a knowledge of the particular system is essential. Leakage past seals and valves may often be found by checking the exhaust pipes, or by removing a connection and substituting a length of hose, the other end of which is held below the surface in a bucket of water; bubbles will indicate leakage from the component upstream of the disconnected pipe.

6.3.2 **Curing Leaks.** Leakage may be caused by a number of faults, such as deterioration of seals, loosening of nuts, splits in pipes, scoring of cylinder walls, or worn valve seats. Leakage from a pipe connection may sometimes be cured by tightening the union nut, but excessive force must not be used; if the leak persists after tightening, new parts should be fitted. Internal leakage from components will often require their removal for overhaul, but the replacement of seals and gaskets is sometimes permitted. Extreme care is necessary when refitting seals, and special tools may be required; any damage to the seal or component caused by careless handling could result in further leaks. When re-assembling components, absolute cleanliness is essential, and the tests specified in the relevant manual should be carried out before installing them in an aircraft.

7 Storage

Pneumatic components are normally packed in sealed containers or plastic bags, and should not be unpacked until required for use. They should be stored in conditions which are dry, and free from corrosive fumes. The storage life of assemblies is determined by the non-metallic parts, such as seals, that they contain, and upon storage conditions. The date of packing, record of tests carried out, and storage life of a component should be marked on the container, but storage life may also be checked by reference to the Maintenance Manual.

7.1 Pipes are usually blanked and wrapped for storage, but flexible pipes should always be stored in the shape in which they were manufactured or have assumed during use.

7.2 Components removed from storage for installation on an aircraft should be examined for external damage and corrosion, and the condition of all threads should be checked. Where applicable the components should be blown through with clean, dry compressed air, and every precaution should be taken to prevent the ingress of dirt or moisture.

INTENTIONALLY LEFT BLANK

Leaflet 20-80 Control Systems

1 Introduction

The purpose of this Leaflet is to provide general guidance and advice on the inspection procedures for control systems which are either manually operated, power assisted or power operated. The Leaflet should be read in conjunction with the relevant approved drawings and manuals for the aircraft concerned.

2 Control Systems

A control system is defined as a system by which the flight attitude or the propulsive force of an aircraft is changed (BCAR Section A, Chapter A6–2).

2.1 For the purpose of duplicate inspection (see paragraph 2.2), the flight control system includes the main control surfaces, lift and drag devices and trim and feel systems, together with any flight control lock systems and the associated operating mechanisms and controls. In the case of rotorcraft, the flight control system includes the mechanisms used by the pilot to control collective pitch, cyclic pitch and yaw. The engine control system includes the primary engine controls and related control systems (e.g. throttle controls, fuel cock controls, oil-cooler controls) and the mechanisms used by the crew to operate them.

2.2 Duplicate Inspection

A duplicate inspection of a vital point/control system is defined as an inspection which is first made and certified by one qualified person and subsequently made and certified by a second qualified person.

NOTE: Vital Point. Any point on an aircraft at which single malassembly could lead to catastrophe, i.e. result in loss of aircraft and/or in fatalities (see BCAR Section A, Chapter A5–3).

2.2.1 Components, systems or vital points subject to duplicate inspection, must not be disturbed or re-adjusted between the first and second parts of the inspection and the second part of the inspection must, as nearly as possible, follow immediately after the first part.

2.2.2 In some circumstances, due to peculiarities of assembly or accessibility, it may be necessary for both parts of the inspection to be made simultaneously.

3 Inspection of Control System Components

3.1 Control system components, the parts of which are concealed during bench assembly before installation, shall be inspected in duplicate on assembly during manufacture, overhaul or repair.

3.2 Both parts of the duplicate inspection and the results of any tests made during and after final assembly shall be certified on the Inspection Record for the part concerned.

4 Duplicate Inspection of Control Systems

4.1 A duplicate inspection of the control system in the aircraft shall be made:

- a) before the first flight of all aircraft after initial assembly,
 - b) before the first flight after the overhaul, replacement, repair, adjustment or modification of the system. The two parts of the duplicate inspection shall be the final operations and as the purpose of the inspection is to establish the integrity of the system, all work should have been completed. If, after the duplicate inspection has been completed, the control system is disturbed in any way before the first flight, that part of the system which has been disturbed shall be inspected in duplicate (paragraph 2.2) before the aircraft flies.
- 4.2 In some instances it may not be possible after complete assembly of the aircraft to inspect all parts of the system because some sections of the system may get progressively 'boxed in' and sealed during assembly operations. In such cases the condition and security of any section which is liable to be sealed must be established to the satisfaction of the persons named in paragraph 5 before the section is sealed and the related Inspection Record endorsed accordingly.
- 4.3 Inspection Records should be carefully prepared to ensure that any duplicate inspection required at an early stage during assembly operations is clearly indicated, thus avoiding unnecessary dismantling at later stages.
- 4.4 The correct functioning of control systems is at all times of vital importance to airworthiness. It is also essential that suitably licensed aircraft engineers and members of approved inspection organisations responsible for the inspection or duplicate inspection should be thoroughly conversant with the systems concerned. The inspection must be carried out systematically to ensure that each and every part of the system is correctly assembled and is able to operate freely over the specified range of movement without risk of fouling. Also that it is correctly and adequately locked, clean and correctly lubricated and is working in the correct sense in relation to the movement of the control by the crew.

5 Persons Authorised to Certify Duplicate Inspections

- 5.1 Persons authorised to make the first and/or second parts of a duplicate inspection of control systems in accordance with BCAR Section A Chapter A6–2 are as follows:
- a) Aircraft engineers appropriately licensed in Categories A, B, C, D and X.
 - b) Persons employed by approved organisations, who are appropriately authorised to make such inspections and to certify the task itself in accordance with company procedures. For aircraft used for the purpose of commercial air transport, an organisation will be required to hold Part-145 approval.
 - c) For minor adjustments to control systems when the aircraft is away from base, the second part of the duplicate inspection may be performed by a pilot or flight engineer licensed for the type of aircraft concerned, provided that authorisation is granted by the responsible Part-145 approved maintenance organisation if the aircraft is being used for the purpose of commercial air transport.

5.2 Certification

It is recommended that the certification of the duplicate inspection be in the following form:

Duplicate inspection performed in accordance with the requirements of BCAR Section A Chapter A6–2

1st inspection **signature**
 **authority**
2nd inspection **signature**
 **authority**
Date.....

6 General

- 6.1 CS 25, 29 and 27.671(b) state that, in relation to the applicable aeroplanes and helicopters, each element of each control system must be designed, or distinctly and permanently marked, to minimise the probability of incorrect assembly that could result in the malfunction of the system. The interpretive material in AMC.671(b) states that for control systems, which if incorrectly assembled, would hazard the aircraft, the design should be such that at all reasonably possible breakdown points it is mechanically impossible to assemble elements of the system to give an out-of-phase action, reversed controls or interconnection between two systems which was not intended; only in exceptional circumstances should distinctive marking be used.
- 6.2 These requirements are satisfied in practice in a number of ways, e.g. by the use of end fittings having different diameter threads for different cables, by the use of different diameter pins in correspondingly different diameter holes in end fittings, by staggering the positions of breakdown points so that cross-connecting, etc., is impossible.
- 6.3 The above requirements do not however, minimise the necessity of thorough end-to-end inspection of each control run. Cases are on record of control cables being crossed and re-crossed so that the relative movements of the controls and the control surfaces were correct.

7 Schedule of Inspection

A schedule of all inspections and functioning checks applicable should be compiled to ensure that no part of the system is overlooked. The schedule should include as a minimum, sufficient instructions to enable the following to be completed:

- a) The duplicate inspection of parts of components which will be concealed during bench assembly.

NOTE: Where such work is the subject of a sub-contract order, instructions regarding inspection and duplicate inspection should be stated on the order and incoming release documentation should be endorsed to the effect that such inspections have been completed.

- b) The duplicate inspection of the internal locking and critical assembly features the correctness of which cannot be proved during final inspection or functioning tests with the assembly installed in the aircraft.

- c) The duplicate inspection of parts of the control system which may subsequently be obscured by the erection of further structure.
- d) The duplicate inspection, functioning and checking for correct relative movement of the complete system.
- e) The final inspection of the complete system to ensure that all covers, guards, etc., are correctly fitted.
- f) The recording of control surface movements and the serial numbers of components.

NOTE: In considering the instructions to be included in a Schedule of Inspection, it should be noted that the term "control systems" includes (for the purpose of this Leaflet) all power-operated or power-assisted controls together with their attachments and operating mechanism which in any way change the flight attitude or propulsive power of the aircraft. Only when other controls, such as an engine auto-stabiliser or an automatic control unit or parts of these units are interconnected with the control system in such a way that they cannot be instantly overridden by the crew in flight, are they considered as part of the control system.

8 Powered Controls

8.1 Power-assisted Controls

In this type of control, part of the force needed to move the control surface is provided by a power system and part by the physical effort of the pilot. The pilot's 'feel' is thus provided by the control surface loads.

- 8.1.1 Initial movement of the pilot's controls produces (by mechanical connection) a small movement of the control surface which operates a control valve causing the control jack to follow-up, thus providing the bulk of the force to permit the movement of the control surface. As the control surface reaches the position appropriate to the position of the pilot's control, the valve is closed and the system comes to rest.
- 8.1.2 In the event of power failure or faults in the power system, satisfactory control can be maintained by manual means. A disconnecting mechanism is usually provided to prevent interference from the power system when it is not in use.
- 8.1.3 The trim control of power-assisted control systems is usually provided by conventional trailing-edge tabs, as for manually-operated flying control systems.

8.2 Power-operated Controls

In this type of system the whole of the force needed to operate the control surfaces is provided by power systems independent of each other but working in parallel.

- 8.2.1 Movement of the pilot's control operates a valve controlling an appropriate mechanism which operates the control surfaces until they reach the position appropriate to that of the pilot's control, when the valve is closed and the system comes to rest. It is not inherent in the system that the pilot's 'feel' should have any direct connection to the force on the control surface and this together with the self-centring of the controls, is achieved by artificial means. The two most common methods of providing feel are:
 - a) constant load for a given control position imposed by a spring strut; and
 - b) a variable loading related to airspeed and applied by a 'q' system, i.e. a force mathematically proportional to the square of the speed of the aircraft.

- 8.2.2 To provide for the event of power failure or faults in the power-operating mechanism, manual reversion might be provided, or there may be two or more systems, each with its own independent hydraulic system having additional pumps to safeguard against failure of their own pressure sources. In controls incorporating three power systems, where the servo unit is attached to the main structure and the jack rams move to control the aerofoil surface, a seizure of the unit selector valve could cause a hydraulic lock in the jack concerned. In this unlikely event the combined pressure of the two other jacks is designed to cause a safety relief valve in the defective unit to open, thus maintaining normal power control. The independent systems may operate one at a time, requiring manual changeover if a fault develops, or may be operating all the time in harmony, with a device to cut out (by manual selection or automatically) the system which fails to operate correctly.
- 8.2.3 Since power-operated controls are irreversible, it is not usual to make use of the conventional trailing-edge trim tab and trim is often obtained by adjusting the zero position of the artificial feel mechanism. However, balance tabs are sometimes fitted to assist in maintaining hinge and servo loads to within the design values.

9 Installation of Flying Controls

The flying controls must be installed in accordance with the requirements prescribed in the relevant approved drawings and documents associated with the drawings, or with the requirements of the relevant manual. All parts used in the installation (e.g. electrical, hydraulic and pneumatic parts of the system) must bear evidence of prior inspection and where applicable, duplicate inspection. It must be ensured that the highest standards of workmanship and cleanliness have been observed and that no parts have been damaged or subjected to distortion during assembly.

9.1 Pulleys and Sprockets

All pulleys and sprockets must be aligned to provide a satisfactory 'run' for the cables and chains so preventing riding on the flanges of the pulleys and sprockets and chafing against the guards and covers.

- 9.1.1 The pulley and sprocket bearings should be examined to ensure that they are properly lubricated, rotate freely and are free from dirt, swarf and paint spray, etc.
- 9.1.2 Non-metallic pulleys should be examined for freedom from embedded foreign matter and metal pulleys for freedom from roughness and sharp edges.

9.2 Guards and Covers

Pulleys and sprockets must be guarded to prevent jamming of cables and chains. The guards and covers must be so fitted and locked that they cannot foul the controls in any position and are held positively against rotation about the pulley or sprocket axis. Where a guard forms an integral part of a removable panel, adequate precautions must be taken to check the controls and the correct positioning of the guard after the panel has been replaced.

- 9.2.1 Glands, gaiters, etc., intended to prevent the escape of lubricant, ingress of foreign matter or loss of cabin pressure where controls pass through pressurised areas, must be undamaged and correctly and securely attached.
- 9.2.2 When longitudinally-split rubber seals are fitted at pressure bulkheads to seal the apertures through which control cables pass, care must be taken to ensure that the assembly is such that the seal will not be chafed as this could result in the seal being broken permitting the retaining rings to come off and ride along the control cable, possibly causing jamming of a pulley. Care must also be taken to ensure that the

retaining rings are installed correctly into the groove in the seal to prevent a similar occurrence.

9.3 **Levers and Fairleads**

All levers and fairleads should be aligned to give the required run without chafing. After installation the levers should be checked for free and unrestricted movement.

9.4 **Chains**

Information on the assembly, testing and installation of chains is given in Leaflet 20-40 and should be read in conjunction with this Leaflet.

9.5 **Cables**

Information on the assembly and testing of spliced and swaged cables is given in Leaflet D-20.

9.5.1 Before installing a cable which has an identification tag affixed other than as shown in British Standards BS SP53, SP54, SP105 and SP106, the tag should be removed and for future identification purposes, the particulars on it should be entered in the Aircraft Log Book.

9.5.2 Where applicable the protective treatment specified should be applied to the cables. However, where the cables pass through or over fairleads, any excess greasy substance should be removed to prevent these parts collecting abrasive dust which would wear the cables.

NOTE: In order to improve the wear and fatigue life of control cables, British Standards require a lubricant to be applied during spinning of the cable. It is important, therefore, when cleaning cables not to wash out the lubricant by saturating the cable with a grease solvent.

9.5.3 The cables should be free from broken wires or other defects, e.g. kinks and 'bird-caging', which would affect their strength.

9.5.4 It is important the cables should be correctly tensioned and this can be helped by having the control surface locks in position during tensioning to support the weight of the control surfaces. During tensioning, adjustment should be made equally on all turnbuckles, otherwise circuits which incorporate a number of pulleys and fairleads and/or where the cables have to negotiate several bends may be difficult to tension evenly.

9.5.5 Where the tension is specified in the drawing or manual, this should be checked by means of a tension meter specified for the weight of cable concerned, due allowance being made for temperature. To obtain a true reading the tension meter should be placed in the position on the cable indicated in the drawing or manual. In the absence of a position being specified it should be placed away from fairleads and pulleys.

NOTE: Where long cable runs are concerned, drawings and manuals often detail the tensions required over a range of ambient temperatures.

9.5.6 Where the tension is not specified it should be ensured that the cable run is not too slack or too taut but has a satisfactory 'feel' over the whole range of travel of the controls.

9.5.7 Turnbuckles should be locked (using wire of the gauge and specification quoted in the relevant drawing or manual) using any of the methods illustrated in Figures 1 to 3. Prior to locking, it should be ensured that the end-fittings are 'in safety' (i.e. the internal fitting extends past the inspection hole in the external fitting) by attempting to pass a hardened pin probe through the inspection hole. Locking wire must not be used more than once.

NOTE: Some turnbuckles are designed so that they can be locked by special locking devices (e.g. spring locking clips to MS2 1256). Instructions regarding their assembly and use should be obtained from the relevant manual.

- 9.5.8 With the larger type of control cables (i.e. cables from 45 to 120 cwt), it has been found that tension loads tend to straighten out the helically-wound cable resulting in a torque action sufficient to break the locking wire or release lock nuts on turnbuckles or similar assemblies. To overcome this 'unlocking' action a tube fitted over the turnbuckle assembly and drilled to accommodate three bolts is often specified. This provides a positive means of preventing independent rotation of any part of the assembly.

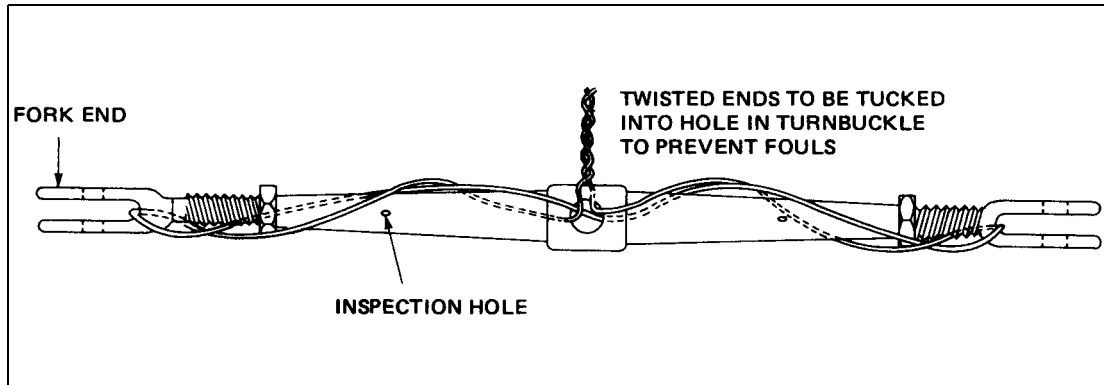

Figure 1 Wire-locking of Turnbuckle with Fork End-fittings

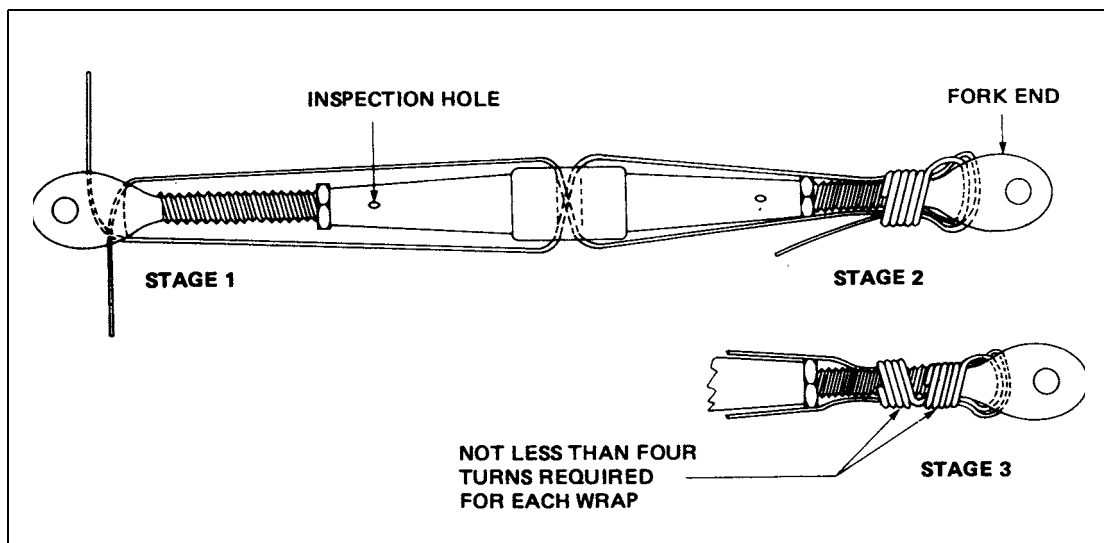

Figure 2 Alternative Method of Wire-locking Turnbuckle with Fork End-fittings

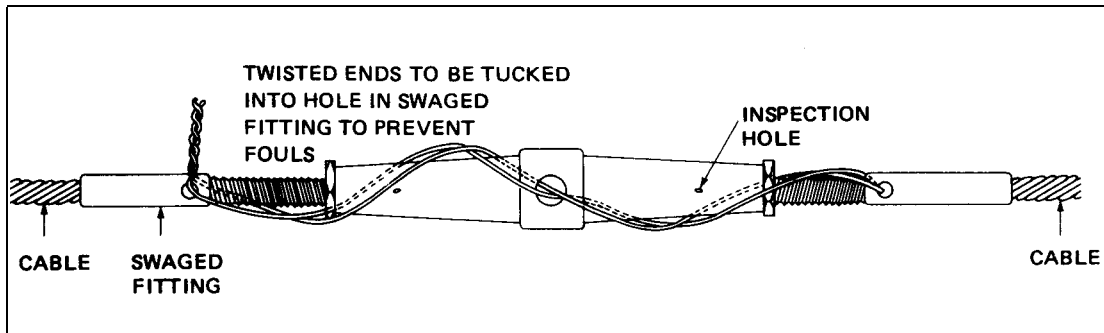

Figure 3 Wire-locking of Turnbuckle with Swaged End-fittings

- 9.5.9 The adjustable end-fitting shown in Figure 4 may be attached, for example, to a swaged cable, a chain or a tension rod. The threaded end must be in safety and the locknut adequately tightened. The screwed portion (A) must not abut the fitting (B) in the fork end as this would impose an additional strain on the fitting, the joint would lack flexibility and there would be no provision for further adjustment.

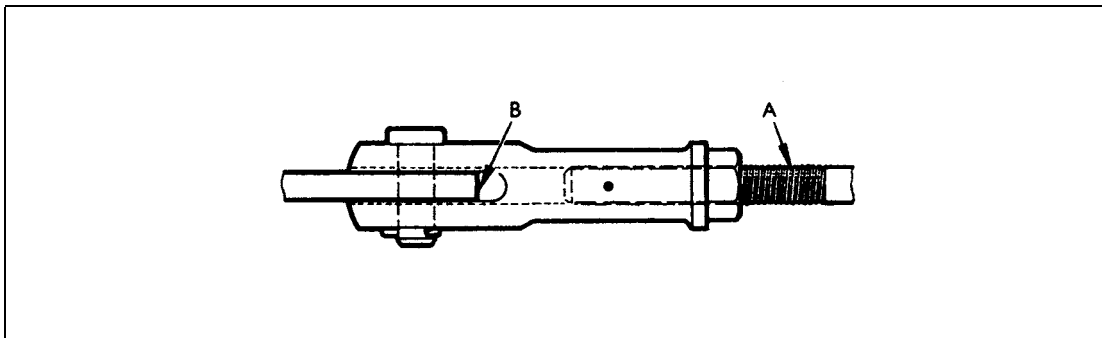

Figure 4 Adjustable Fork End-fitting

9.6 Control Rods

Control rods should be perfectly straight (unless designed to be otherwise) when fitted and bell-cranks, etc., to which they are attached, should be checked for freedom of movement before and after assembly of the control rods. The assembly as a whole should be checked for correct alignment.

- 9.6.1 Where self-aligning ball-races are fitted, free rotational movement of the rods must be obtained in all positions.
- 9.6.2 There have been cases of control rods with self-aligning bearings becoming disconnected because of failure of the peening retaining the ball-races in the rod end housings, thus allowing the rods to become detached from the ball-races. This can be obviated if the control rods are assembled so that the abutment flange of the rod end housing is interposed between the ball-race and the anchored (as opposed to the free) end of the attachment pin or bolt (see Figure 5). Alternatively, a washer having a larger diameter than the hole in the abutment flange may be required under the retaining nut on the end of the attachment pin.

9.7 Gearboxes and Torque Tubes

Where this type of equipment is installed in the system, it should be ensured that the gearboxes are correctly mounted, that the torque tubes are not bowed and run freely in their guides, that universal joints are correctly fitted and give the correct degree of angular transmission throughout a complete rotation of the torque tube and that only the lubricant specified by the aircraft manufacturer is used in the gearbox.

9.8 Control Surfaces, Tabs, etc.

The method of attachment varies with each type of aircraft, but it must be ensured that the component is assembled to the aircraft without strain and that adequate clearance exists between adjacent control surfaces, or between the control surface and adjacent structure and shrouds, throughout the full range of movement. There must be no slackness in linkage which may cause collective backlash and introduce control flutter.

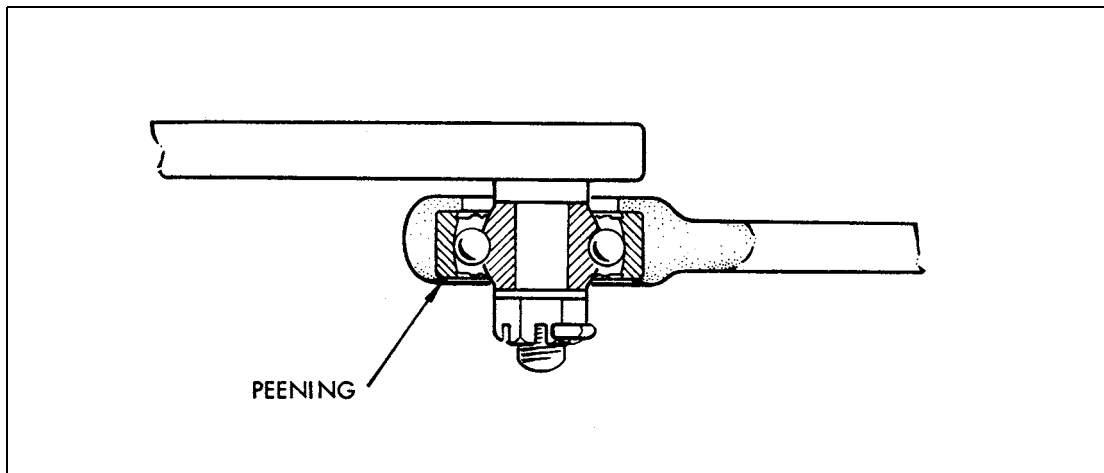

Figure 5 Self-aligning Bearing

9.9 Rotor Blades

Rotor blades are particularly susceptible to damage and are sensitive to the effects of damage. Particular care is necessary therefore, when handling and assembling rotor blades to prevent them becoming dented or scored. The attachment of rotor blades must be inspected in duplicate as must the re-securing of the blades after unfolding.

9.10 Locking

All connections of components and parts in the control system must be positively secured and locked in accordance with drawing requirements (see Leaflet 51-100).

9.11 Lubrication

All moving parts should be lubricated with the specified lubricant during assembly. Proprietary bearings, such as those of the oil-retaining variety, should receive lubrication only when recommended by the manufacturer.

9.12 Placarding

A check should be made to ensure that all placards and notices relating to the functions, direction of movement and operational positions of controls, levers, handles, etc., are clearly and correctly applied in accordance with drawing requirements and are in their specified positions.

NOTE: It is important that all placards and labels should be maintained in a clean and legible condition.

9.13 General

During installation, care must be taken to avoid any possibility of the controls jamming or fouling against adjacent structure, or cables rubbing together or chafing against other fixed or moving parts throughout their range of movement. Where clearances are not stated on drawings and there is some doubt about their adequacy, the guidance of the approved Design Organisation should be sought. The system should be protected against corrosion and deterioration and should be effectively bonded.

10 Control Settings

10.1 Manually operated

The manual operation of the system should be witnessed whilst the controls are operated throughout their full range. This should be carried out in quiet conditions as some mechanical defects can be detected by an unusual noise. The primary systems should be checked for static friction, using a spring balance. The CAA recommends that the forces on the control column or wheel and rudder pedals necessary to overcome static friction should not exceed the values given in Table 1. In the case of systems incorporating cables, these conditions should be met with the cables rigged at the stipulated tensions.

Table 1

Maximum Weight of Aeroplane kg(lb)	Maximum Static Force on Control N(lbf)		
	Elevator	Aileron	Rudder
5700 kg (12 500 lb) or less	17.79 N (4 lbf)	8.89 N (2 lbf)	26.68 N (6 lbf)
22 680 kg (50 000 lb) or more	44.48 N (10 lbf)	35.59 N (8 lbf)	44.48 N (10 lbf)
Linear variation should be assumed between these weights.			

10.2 The full and synchronised movement of the controls should be checked to the relevant rigging diagrams and the limit stops adjusted as necessary to the relevant rigging diagram requirements. The stops should be relocked. It is important that the pilot's controls and control surfaces contact their stops in the correct sequence.

NOTE: When checking the range of movement of the control surfaces, it is important that the controls should be operated by the pilot's controls and not by handling the control surfaces. It should be ensured that all obstructions, such as trestles, are out of the way of control surfaces.

10.3 During the checking of settings it should be ensured that collective backlash in the system does not exceed permitted limits and when controls are in the 'full-travel' position and against their respective stops, that chains, cables, etc., have not reached the limit of their travel. Where dual control facilities are provided, it should be ensured that they are correctly synchronised and function satisfactorily when operated from both positions.

10.4 Where components or control systems are interconnected, it should be ensured that they are correctly co-ordinated in accordance with drawing requirements.

10.5 Where friction devices are employed, it should be ensured that the selected degree of friction is applied to the controls throughout the range of movement.

10.6 Trim tabs and other tabs should be checked in a similar manner to the main control surfaces, it being ensured that any devices for indicating the position of the tabs function correctly. When screw jacks are employed to actuate the tab, care must be taken to ensure that they are not out of safety when in the fully extended position.

10.7 Where spring devices are fitted in the control system, these should be checked for correct tension, cleanliness and adequate lubrication.

10.8 Guidance on control functioning checks for aeroplanes and rotorcraft is given in paragraph 11.

10.9 **Powered Controls**

The rigging of powered controls varies with each type of aircraft, therefore, it is impracticable to attempt in this Leaflet to define a procedure; it is essential to follow the manufacturer's requirements in this respect. However, reference can be made to the nature of the precautions which should be taken when rigging such systems.

10.10 It is of the utmost importance that each system should be correctly adjusted and all means of adjustment correctly locked. Where cables are used in powered control systems, it is essential that they are correctly tensioned to prevent malfunctioning of the actuating units. The tensioning requirements, the type of tension meter to be used and the positions where readings are to be taken will be prescribed in the relevant manual for the aircraft concerned. To compensate for structural flexing and changes in temperature, cable-tension compensator-units are sometimes incorporated in the control circuit; these compensators should be pre-set and the system adjusted as prescribed in the relevant manual. To simplify the adjustment, compensator units may be provided with scales or datum holes to indicate when the adjustment is correct.

10.11 It is important during initial setting that jacks do not bottom, unless the relevant manual so specifies, as this may result in over-stressing of parts of the unit which could lead to failure in service.

10.12 Pins, usually 'rigging' pins (which must have a red warning flag permanently attached), are sometimes required to simplify the setting of such parts as pulleys, levers, hydraulic control units, etc., in their neutral positions by inserting the pins in the alignment holes provided. This arrangement also simplifies the correct alignment and tensioning of the various control systems. When rigging pins are not provided, the neutral positions may be checked by means of alignment marks, by the use of special templates or by taking linear measurements; these procedures will be clearly defined in the relevant manuals.

NOTE: To prevent damage to the control system, if by error rigging pins were left in position, some rigging pins are designed to have a maximum shear value and only those designed for the system concerned should be used, but in general, the accuracy of diameter and correct fitting are the important considerations. Ground locking devices should never be used in lieu of rigging pins.

10.13 If the final alignment and adjustment of the system is correct, it should be possible to withdraw the rigging pins easily. Any undue tightness of the pins in the rigging holes indicates incorrect tensioning or malalignment of the system.

NOTE: All rigging pins or centralising devices must be removed immediately after the rigging operation is completed and before operating the power systems, otherwise damage may result. This precaution must be made part of the control system clearance procedure. Similarly, precautions should be taken to ensure that all obstructions, such as trestles, are out of the way of control surfaces.

10.14 When static friction tests are prescribed for the control circuits, these should be done with a spring balance or suitable test rig in the manner prescribed and must not exceed the limiting values permitted. In some power-assisted systems, excessive friction could upset the feel of the system to the detriment of the handling qualities of the aircraft.

NOTE: In some instances it may be necessary to disconnect the 'feel' spring struts in order that the true friction value can be obtained. It may also be necessary to check spring-strut break-out forces following the static check.

- 10.15 Since the hydraulic systems are independent of each other, a check should be made to ensure that the routing of all pipelines and electrical cables does give the necessary isolation. In addition, pipelines and electrical cables should be checked for signs of chafing while the systems are functioning.
- 10.16 It is essential that all control functioning checks and tests are carried out strictly in accordance with the manufacturers' publications.
- NOTE:** It must be ensured that test rigs contain the correct fluid and are provided with the same standard of filtration as is provided on the aircraft.
- 10.17 The correct engagement and disengagement of control locks should be checked at the same time as a check on the correct functioning of the associated warning devices.
- 10.18 The range of movement of the controls and control surfaces should be checked in both directions from the neutral position. If the range does not meet the rigging tolerances, the necessary adjustments should be made and the duplicate inspection completed (see paragraph 4).
- 10.19 Where components in control systems are interconnected, their operation should be correctly co-ordinated in accordance with drawing requirements. Where friction devices are employed, it should be ensured that the selected degree of friction is applied to the controls throughout the range of movement.
- 10.20 When testing the system, all hydraulic equipment and pipelines should be checked for leaks. The appropriate filters should be checked for cleanliness and freedom from damage and particular care should be taken to follow the instructions given in the relevant manual, as a broken or disintegrated filter may cause a valve to jam. Where 'tell-tale' indicators are incorporated in filters these should be checked at the periods specified. After checking for cleanliness, all air should be expelled from the systems.
- 10.21 **Engine Ground Run Test**
- As some parts of the hydraulic systems are not tested with the hydraulic test rig, the controls should be operated during a convenient ground test run to ensure that all engine pumps operate satisfactorily over the speed range of the pumps. Where part of a hydraulic system has been disconnected, e.g. to change an engine or pump, precautions should be taken to expel any air which may have entered the system and the operation of the system should be rechecked.

11 Control Functioning

The final functioning checks on control systems is of the greatest importance and it is essential that they should be completed systematically. The checks should be carried out after thorough cleaning and only when all other work on the system has been completed.

11.1 Aeroplanes

- 11.1.1 The functioning checks must include verification that full, free and correct movement of the controls is obtained throughout the system relative to the movement of the crew controls.
- 11.1.2 A list of all controls and the salient checking points should be drawn up in a suitable sequence and in duplicate.
- 11.1.3 A person competent to certify a duplicate inspection should operate the controls in the cockpit, maintaining the sequence specified in the checking list. Another person competent to certify the duplicate inspection should check on the control movements

in the same sequence. For the second part of the inspection the two persons should exchange positions and repeat the checks in identical sequence.

- 11.1.4 The relative movements of the control surfaces in relation to the pilot's controls should be carefully checked to the manufacturer's instructions.

NOTE: Where 'free operating control surfaces' are installed the relative movements of controls are affected. For example, if the control column is moved back, the elevator does not move at all, but the tab of the elevator moves downwards causing the elevator to move upwards in flight. This type of control system requires a special checking technique and the manufacturer's instructions must be closely followed.

- 11.1.5 The movement of wing-flaps and slats should be checked for synchronisation and a check should be made to ensure that the relevant surface position indicator accurately registers the position of the surfaces throughout their range of movement.

- a) A check should be made (where applicable) to ensure that the wing-flap or slat asymmetric control device is functioning correctly.
- b) Where wing-flaps are interconnected with leading-edge flaps or slats, the installation should be checked for correct operation during extension and retraction of the wing-flaps.

- 11.1.6 Where spoilers/speed brakes are interconnected with the aileron control system, their correct operation in relation to the ailerons should be checked.

- 11.1.7 Where an aerodynamic feel simulator is connected into the main control systems, its correct operation should be checked with the aid of a suitable pitot system test rig.

- 11.1.8 It should be ensured that when operational time limits are specified for certain controls, e.g. flaps, spoilers or speed brakes, these are within permitted limits.

11.2 **Rotorcraft**

- 11.2.1 A list of all controls affected and the salient checking points should be drawn up in a suitable sequence and used as indicated in the relevant parts of paragraph 7.

- 11.2.2 The nature of the functioning checks necessary will vary with the system concerned, but where applicable the following should be checked:

- a) That the direction of movement of the main and tail rotor blades or other related controls in relation to the movement of the pilot's controls is correct.
- b) That the operation of interconnected control systems (e.g. engine-throttle and collective-pitch controls) are co-ordinated in accordance with drawing requirements.
- c) That the range of movement and neutral positions of the pilot's controls (i.e. cyclic-pitch control columns, collective-pitch levers and yaw pedals) are as specified in the relevant drawings.
- d) That the maximum and minimum pitch angles of the main rotor blades, in both fore-and-aft and lateral cyclic-pitch, are within drawing requirements.
- e) That the maximum and minimum pitch angles of the main rotor blades in collective pitch are within drawing requirements.
- f) That, in the case of multi-rotor aircraft, the rigging and the movement of the blades of the rotor are in correct synchronisation.
- g) That the tracking of the main rotor blades is satisfactory.
- h) That, when tabs are provided on main rotor blades, these are correctly set.

- i) That the neutral, maximum and minimum pitch angles and coning angles of the tail rotor blades are in accordance with drawing requirements.
- j) That, when dual controls are provided, these function correctly and in synchronisation when operated from both positions.
- k) That, to comply with the relevant chapters of BCAR, the static operating loads of the system are not excessive and when specified, do not exceed drawing requirements.

11.2.3 Tracking Checks

When the main rotors do not 'cone' by the same amount during rotation, they are said to be 'out of track'. This may result in excessive vibration at the control column. Tracking checks should be carried out at the prescribed engine operating conditions, if possible in still air. Where it is not possible to obtain still-air conditions, the rotorcraft should be faced into a wind not exceeding 10 knots and free from gusts.

11.2.4 Tab Setting

The setting of the tabs on main rotor blades (if provided) should be checked to eliminate out-of-balance moments which will apply torque to the rotor blades. The tab setting should be checked for correctness by running the rotor at the prescribed speed and ensuring that the cyclic-pitch control column remains stationary. Out-of-balance moments impart a stirring motion to the column.

11.2.5 Checking Blade Angles

Before checking blade angles it must be ensured that the rotorcraft and where applicable, the rotorhead, is set up in the correct lateral and longitudinal position. The blades must be set in the specified position for the check. The blade angle should be checked on each blade in turn and when specified, the angles of the subsidiary blades on the main rotor must agree with those of the master blade within the prescribed limits. When it is necessary to adjust the initial blade rigging in order to obtain correct tracking or acceptable flight characteristics, the rigging should be re-checked after test flying has been completed to ensure that it is within permitted limits.

11.3 Control Locks

A check should be made on internal ground control-locking systems to ensure they are positive in action, engage fully in the 'locked' position and have adequate clearance in accordance with drawing requirements in the 'unlocked' position. There should be no possibility of interference between the locks and the controls over the full range of movement of the latter.

11.4 Inspection after Functioning

When the functioning checks have been completed, all checking equipment should be removed from the aircraft and a final inspection made to ensure that the systems are free from all foreign matter which might cause jamming (e.g. nuts, bolts and small tools). All access panels should be replaced, care being taken to make sure that securing screws are the correct length not to foul the controls and that chains and cables retaining the access panels are correctly fitted.

12 Automatic-pilot Installations

The information in this paragraph does not apply to any particular type of installation of automatic-pilot but gives general guidance on essential points which relate to the flying control system. Any moving parts of the automatic-pilot that constitute integral

parts of the normal control system, whether the automatic-pilot is 'in' or 'out', should be regarded as part of the flying control system and should be inspected in accordance with the procedure given in this Leaflet.

- 12.1 When the automatic controls are disengaged, the normal controls should function satisfactorily, e.g. the resistance offered by the automatic-pilot motors, where applicable, should not affect the control of the aircraft.
- 12.2 A check should be made on the means provided for disconnecting the automatic-pilot from the normal controls to ensure it is possible to do so at all positions of the controls and that the manual override of the automatic-pilot is satisfactory.
- 12.3 The interconnecting mechanism between the automatic-pilot and the normal controls should give the required range of travel and should be correctly aligned and smooth and positive in operation. The clearance should be in accordance with drawing requirements.
- 12.4 Operating cables, where applicable, should be checked for tension in the manner applicable to the particular installation.

13 Ground Test – After Overhaul or Major Dismantling

- 13.1 All rigging pins or retaining devices should have been removed from the controls. Where control locks are not provided, it may be necessary to support the control surfaces until the system is functioning. The control surfaces should be checked for freedom from obstruction and the automatic-pilot should be disengaged.
- 13.2 If any one of the independent systems has been disturbed, a complete series of checks required to test that system should be made. Where any rectification affects more than one system or where there is any possibility of the functioning of all systems being affected, then the complete series of checks to test all systems should be made.

14 Periodic Inspections

Periodic inspections on the complete flying control systems should be carried out in accordance with the requirements of the Maintenance Schedule or manufacturer's Manual.

INTENTIONALLY LEFT BLANK

Chapter 24 Electrical Power

Leaflet 24-10 Charging Rooms for Aircraft Batteries

1 Introduction

This Leaflet gives guidance on the setting-up and operation of rooms equipped for the purpose of charging aircraft batteries.

- 1.1 Mandatory provisions for the setting-up and operation of battery charging rooms are contained within the Factories Act.
- 1.2 The following Leaflet contains information associated with the subject covered by this Leaflet and reference should be made to it, as appropriate.

D-40 Storage Conditions for Aeronautical Supplies

2 Building and Equipment

2.1 General

- 2.1.1 In no circumstance should the same facility be used for both nickel-cadmium and lead-acid battery charging; and the ventilation arrangements shall be such that no cross contamination can occur.
- 2.1.2 Buildings and rooms used for the purpose of charging batteries should be well lit and cool and should have a ventilation system which is capable of exhausting all the gases and fumes which may be present during the servicing and charging operations. The floor surface should be of a material which is impervious to acid and alkali, has non-slip qualities and is quick drying and able to be washed down easily. Examples of such materials are dustless concrete, bituminous compound or tiling. Adequate and suitable drainage should be provided for washing down purposes. Because of the fire risk, it is strongly recommended that doors should be fitted so that they open outwards, thus facilitating easy evacuation from the building in the event of fire. To permit free and easy movement of batteries, steps and thresholds should, where possible, be eliminated. If, however, different levels are unavoidable they should be linked by inclines.

2.2 Water Supply

At least one tap in each room where battery charging is carried out should be connected to a mains fresh water supply. Sinks and draining boards and a hot water supply should also be provided.

2.3 Lighting

The level of lighting within the charging rooms should be sufficient to enable the level of the electrolyte in individual cells of batteries to be easily determined without additional lighting. To prevent accidental ignition of gases all electrical fittings should be of a sparkproof design.

2.4 Ventilation

Hydrogen is given off at all stages of lead-acid battery servicing; the highest concentration being at the end of the charging cycle. Hydrogen is also produced when nickel-cadmium batteries reach the fully charged state; i.e. at the 'overcharge' point and for a 24 hour period thereafter. Heavy corrosive fumes are also emitted when mixing of electrolytes takes place. Therefore, a ventilation system is required which is capable of extracting all gases and fumes, whether heavier or lighter than air.

2.5 Temperatures

2.5.1 Electrolyte Temperature

The maximum permissible electrolyte temperature during charging is normally 50°C (122°F), but some batteries of special design, however, have lower limits; for such batteries the temperature limitations will be specified in the manufacturer's publication for that battery.

2.5.2 Environmental Temperature

Environmental temperatures exceeding 27°C (81°F) for lead-acid batteries and 21°C (70°F) for nickel-cadmium batteries impose time penalties in reaching the fully charged state and may also be deleterious to the batteries. The temperature of battery charging rooms should, therefore, be maintained at a temperature consistent with specified limitations and with a free air flow around each battery or cell.

3 Charging Boards and Benches

3.1 Detailed differences exist between the various types of charging board, but in general each board consists of a pair of terminals, to which the rectified a.c. supply is connected (or in the case of a board which has a built-in rectifier unit, to which the mains supply is connected), together with a number of pairs of output terminals, to which the batteries are connected for charging.

3.2 All the output circuits are internally connected in parallel and are, therefore, independent of each other, with the level of charge being controlled separately for each output circuit. Each pair of output terminals is normally designed to have one group of batteries or cells connected in series.

NOTE: Parallel connection of batteries to one pair of output terminals is not permitted.

3.3 Charging boards should be mounted directly above the rear of the benches so that the necessity for long connecting cables is avoided.

3.4 Battery connecting cables should be well insulated and should be of a sufficient capacity to carry the charging current required. The free ends of connecting cables should be fitted with suitable connectors, which should be firmly secured to the battery and charging board before commencing charging operations. Connections to the charging boards should not be made or broken when power is switched on. On completion of the charging cycle, power should be switched off and the charging cables should be disconnected, first from the battery and then from the charging board.

3.5 Benches

3.5.1 Benches and associated equipment should be sited so that the need for personnel to lean over batteries is kept to a minimum. It is recommended that the height of battery charging benches be approximately 0.5 m (20 in) from the floor. At this height, lifting strain is minimised and a more effective visual inspection of the batteries can be made.

- 3.5.2 The surfaces of battery charging benches should be acid and alkali resistive and should facilitate cleaning. It is generally considered that batteries should not be allowed to stand directly on wood or concrete, but should rest on suitable grids.

4 Power Supplies

- 4.1 Transformer/rectifiers which normally provide rectified a.c. for charging board supplies should be sited in a fume free, dry and cool position, preferably in a separate room, located as near as possible to the charging boards. Charging boards which require 240 volts mains supply, should be supplied from a ring main system.

5 Storage

5.1 Batteries

In order to preserve an orderly flow of work through a battery charging room, storage facilities should be provided such that incoming unserviceable batteries may be separated from those ready for issue, preferably in clearly placarded areas. The storage facilities should be further grouped for those batteries requiring initial charge and those awaiting routine servicing. Batteries which are serviceable and awaiting issue are best stored in an area which is not subjected to excessive vibration. It is essential that whilst in store, lead-acid batteries be segregated at all times from nickel-cadmium batteries; preferably in separate store rooms. For further information on the long term storage of batteries, reference should be made to Leaflet D-40.

5.2 Electrolytes

- 5.2.1 The handling and storage of electrolyte materials should always be in accordance with the manufacturer's instructions. It is, however, essential that when undertaking the mixing or breaking down of these chemicals, separate areas are provided. Glass, earthenware or lead-lined wood containers are suitable for the storage of lead-acid battery electrolyte (sulphuric acid), whilst plain iron, glass or earthenware containers are suitable for the storage of nickel-cadmium battery electrolyte (potassium hydroxide). Galvanised containers or containers with soldered seams must not be used. Each container should be clearly marked as to its contents and should be stored accordingly. Waste or surplus materials should be disposed of in accordance with locally approved instructions. If, however, doubt exists, all electrolytes should be neutralised prior to disposal (paragraph 5.4). All mixing vessels, mixing rods and other similar items should be clearly marked with 'acid only' or 'alkaline only' and their use should be restricted accordingly.
- 5.2.2 Stocks of electrolyte materials which are retained in a battery charging room should be restricted to the quantities required for immediate use. The storing of electrolytes mixed ready for use should be avoided as far as possible.
- a) Sulphuric acid containers should be kept tightly sealed when not in use, to prevent contamination. Only the container which is required for immediate use should be retained in the charging room.
 - b) Potassium hydroxide is supplied in solid form contained in steel drums. Once a drum has been opened the contents are liable to carbon dioxide contamination. The entire contents should, therefore, always be mixed as soon as a drum has been opened. Any unused mixture should be stored in a stoppered glass container.
- 5.3 De-mineralised and distilled water are generally supplied in carboys and should be stored separately from the electrolytes, so as to avoid contamination. Carboys should

be firmly stoppered when not in use and should be clearly marked as to the contents. Only the water container used for 'topping up' should be kept in the charging room and the stopper should be refitted immediately after use.

- 5.4 The neutralising agents for the two types of electrolytes are given below, together with the action that should be taken in the event of contamination and/or spillage.

5.4.1 **Sulphuric Acid**

The neutralising agents are:

- a) Saturated solution of bicarbonate of soda.
- b) Ammonia powder.
- c) Borax powder.

The acid should be soaked up with sawdust which should then be removed and buried. The affected area should be treated with one of the above, followed by washing down with copious amounts of fresh water.

5.4.2 **Potassium Hydroxide**

The neutralising agents are:

- a) Boric acid solution.
- b) Boric acid crystals or powder.

The alkali should be soaked up with sawdust, which should then be removed and buried. The affected area should be treated with one of the above, followed by washing down with copious amounts of fresh water.

- 5.4.3 Containers of sawdust and neutralising agents should be clearly marked with their contents and use and sited in readily accessible positions.

6 Protection

- 6.1 To prevent the risk of burns, such personal items as rings, metal watches, watchstraps and identification bracelets should be removed, to avoid contact with connecting links and terminals. Personal protection against the harmful effects of acid and alkali contamination should be in accordance with the provisions of the Factories Act.
- 6.2 In general, smoking should only be permitted in rooms which do not have a direct access to battery charging rooms or chemical mixing areas. Naked lights, non-safety matches and automatic lighters should not be taken into battery charging rooms.
- 6.3 Fire extinguishers of the CO₂ type and buckets of sand should be placed at strategic points inside the building for use in the event of any chemical fires.

7 Documentation

- 7.1 Records of battery servicing should be maintained.

8 Servicing and Test Equipment

- 8.1 Servicing of aircraft batteries should be carried out in accordance with the instructions contained in the manufacturers' Maintenance Manual.

- 8.2 In addition to the general engineering hand tools which may be required for aircraft battery servicing, the following specialised items will also be required:
- a) Hydrometers.
 - b) Thermometers.
 - c) Battery kits (as supplied by battery manufacturers).
 - d) Capacity test sets.
 - e) Leakage tester (lead-acid batteries).
 - f) Filler pumps (for transferring of liquids from one container to another).
 - g) Calibrated test equipment:
 - i) Insulation resistance tester.
 - ii) Universal test meter.
 - iii) Digital voltmeter.
- 8.2.1 To prevent cross-contamination between the two types of aircraft batteries, two sets of equipment should be held, each being contained in separate cupboards and clearly marked 'acid only' or 'alkaline only' as appropriate to the application. Wherever possible, tools and equipment comprising the sets should be those manufactured of an insulating material. Each item should be identified as to its application and in the case of hydrometers and thermometers, this is usually best done on the instrument case.

INTENTIONALLY LEFT BLANK

Leaflet 24-20 Nickel Cadmium Batteries

1 Purpose

This Leaflet is intended to provide guidance material on methods of assessing standards of battery maintenance. This Leaflet replaces that issued on 9 January 2002 under the same subject title. This document recognises actions taken by manufacturers and users since that time and is intended to provide further revised guidance material on methods of assessing standards of battery maintenance. This document also attempts to recognise the improvements made to affected battery types since the original publication on this topic in February 1974.

In addition, Appendix 1 of this Leaflet gives general guidance on the maintenance and installation of nickel-cadmium batteries (in particular of the semi-open type), which provide a standby source of DC power in aircraft. It should be read in conjunction with the Maintenance Manuals and Overhaul Manuals issued by the battery manufacturers, relevant aircraft Maintenance Manuals and approved Maintenance Schedules. It should be noted that Appendix 1 of this Leaflet was previously published as CAIP EEL/1-3 Issue 1 (Dated 14 November 1975).

2 Background

In general, industry has been aware of the dangers of poor nickel cadmium battery maintenance. Whilst the actual number of battery 'runaway' and severe overheating failures have been seen to decrease over the years, it is considered prudent to continue to be vigilant and as such this Leaflet highlights continuing good maintenance practices.

3 Battery Failure Modes

The prime method of assessing any battery is essentially the measurement of discharge capacity and this is sufficiently well appreciated as to require no further comment here. However, for Nickel Cadmium cells of the non sealed type, which are the subject of this document, it is essential that the plate separator is in good condition. Unfortunately, the detection of failure requires close monitoring of cell voltage and it is quite possible for a battery containing cells with failed separators to give acceptable capacity.

The separator in a Nickel Cadmium cell has the obvious task of providing a physical isolation between the plates and less obviously, a significant function in terms of the electrochemistry of the cell. It is composed of a build up of woven nylon or similar material and a non-porous membrane of cellophane. The cellophane acts both as a physical screen against metallic particle penetration and as a gas barrier to prevent oxygen generated by the positive plates during charge from reaching the negative plates. Unfortunately, these separator materials are the first to be damaged as battery temperature is increased and we no longer have the obvious warning signs of distorted cell boxes to show that overheating has occurred as was the position with earlier cells.

Should a damaged separator remain in service, local overheating will occur because of catalytic action at the negative plates and this in turn will cause poor charge acceptance. This generally results in a loss of balance with the other cells, poor capacity, or more seriously an active failure in terms of cell burning. The majority of

such burns are relatively minor and can only be seen when a cell is removed from the battery but it is this same mechanism which can develop to give cell to cell, or cell to case, shorts which may then create significant hazards.

The causes of separator failure can be placed into two broad categories, namely:

- a) adverse aircraft operating conditions – including system management problems, or
- b) poor maintenance – either in terms of battery workshop practice or length of time between servicing.

Clearly, these sub-divisions represent an over simplification but it is convenient to proceed in this document under these headings and to discuss these factors in relation to battery failure in general and cell separator failure in particular.

4 Aircraft Operating Conditions

Basically, there are two groups of aircraft batteries in terms of size and duty, namely high discharge rate units for use with main power systems and small 'dedicated power supply' batteries, of which the Inertial Navigation System unit is typical. This second group is clearly less prone to operational failure because the environment is under closer control and the battery is accommodated within a system design. It follows that the prime concern is to see that batteries remain in a good state of charge and do not become 'sleepy' and this will be considered as a maintenance function (see Paragraph 5).

The main power system batteries can be sub-divided into those which are connected directly to the bus and therefore receive a 'constant potential charge' and those which are connected via a special charging unit which usually provides a combination of limited constant potential charging and constant current charging.

Batteries which 'float' on a main DC bus operate in a very narrow band of acceptable conditions of voltage and temperature and for this reason the larger aircraft do not now use this system. A twenty cell battery which is subject to regular discharge loads is unlikely to regain adequate charge unless it receives 28.5 volts at its terminals but should its temperature be raised by say, engine starting, it is possible that 'thermal runaway' could be initiated at 29.0 volts. These are approximate figures but they do serve to show the importance of ensuring that the voltage of each cell is adequate because the loss of perhaps 0.1 volt from the 'top of charge potential' of each of several cells, can lead to charge instability of the battery. Such voltage reductions will be evident if separators have been damaged and we do have a classic 'cause and effect' problem to consider when such batteries are returned as unserviceable. Because of the disruptive nature of some of the extreme failures experienced in recent years, it is now generally required that batteries operating on a constant potential bus-bar should be monitored for high temperature levels. Typically, there may be an indication available to flight crew that a battery has reached 50°C and a further warning should a battery reach 70°C, at which point electrical disconnection is required.

Batteries which are charged from their own special system are not generally monitored by temperature in the flight deck but the battery may be temperature sensed as part of the method of charge control. The charging current is usually displayed to flight crew and this enables the charging mode to be observed so that disconnection may be made if abnormal operation occurs. Whilst the dramatic 'thermal runaway' is far less likely to occur on such systems, nevertheless, cell burning can and does occur. Examples are known of maintenance staff 'topping up'

batteries on an aircraft, in itself an undesirable practice, only to realise that a failure existed because water issued from ruptured cell boxes.

To summarise, the main causes of cell failure, acting singly or in combination to create a battery failure, are:

- a) excessive discharge duty;
- b) high operating temperature which may be caused either by high discharge current or by ambient conditions;
- c) high DC voltage; or
- d) inadequate maintenance, which will now be considered.

4.1 **Battery Capacity Levels**

In some instances, it may be necessary to establish the battery duration (e.g. for the purpose of producing an Electrical Load Analysis for an aircraft).

The capacity of a battery is defined by the following:

Rate of Charge (Amps) x time to discharge

Normally expressed in ampere, but typically expressed in amp-mins (i.e. amp-hours x 60). However, this is not a linear function and with heavier discharge currents the discharge time decreases more rapidly so that the power available is less (i.e. reduced efficiency).

Therefore, in order to make an accurate assessment of battery duration, reference should be made to the manufacturer's discharge curves. However, it is recognized that these may not be available and certain assumptions and approximations are provided in the following paragraphs to allow for this case.

Because of the problem of definition of capacity, it is first usual to ensure that all calculations are based on the one-hour rate. Some manufactures however do not give this on the nameplate and quote the five-hour rate (i.e. 5C). For these calculations, as a general rule, it may be assumed that the one-hour rate is 85% of the quoted five hour rate.

For the purpose of calculation, a battery capacity at normal ambient conditions of 80% of the nameplate rated capacity, at the one-hour rate, and a 90% state of charge, may be assumed (i.e. 72% of the nominal demonstrated rated one hour capacity at +20°C). The allowance for battery endurance presumes that adequate requirements for periodic battery maintenance have been established.

In some cases, a higher capacity can be recognized (i.e. minimum of 80% of the nominal demonstrated rated capacity at +20°C in lieu of 72%) provided it can be shown that the component maintenance manual (CMM) has a manufacturer's limitation on the state of charge following a battery shop maintenance cycle (e.g. minimum state of charge of 110% following battery shop maintenance cycle). This would then allow a higher duration of the battery to be established.

5 **Maintenance**

Probably the most contentious aspect of battery maintenance is that of frequency of removal from aircraft for workshop servicing. The major battery manufacturers usually indicate periods which can be as low as 50 hours and seldom exceed 500 flying hours or 3 months installed life for batteries connected to a constant potential system. If the quantity of 'consumable electrolyte water' is known, then by monitoring each cell for consumption it may be seen if this amount is being exceeded.

Ideally, the measured water addition to each cell should not exceed this volume (25 cm³ is a typical value) when the battery is returned from service. If a charge controller is fitted to the aircraft and this limits the overcharge current accurately for a given battery, then these maintenance periods may extend, in a typical case, to 1,000 flying hours.

A major factor in determining the frequency of battery maintenance may be the need to 'balance' cells. If it is remembered that a battery is an assembly of 20 or more cells in series and that the capacity of these may range by 30%, it will be apparent that the lowest capacity units may become excessively discharged or even 'reverse' charged. All manufacturers now recommend that, on a regular basis, cells are fully discharged and then individually shorted out. Frequent APU or engine starting is the major cause of unbalance, whilst inactive batteries such as those fitted within an INS will show apparent loss of capacity ('sleepiness') which can only be restored by workshop cycling. Thus installed life has to be determined for each type of operation as well as for each type of cell and due regard should be taken of the rate of consumption of 'electrolyte water'.

Battery manufacturers have now produced maintenance instructions which are of an acceptable standard and it is not proposed to repeat such data here. Additionally, Appendix 1 of this Leaflet gives supporting information but it is appropriate to emphasise the following points:

- a) Record cards showing a history for each battery and including details of the history of each cell are essential.
- b) Cell replacement by units of identical type obtained from the battery manufacturers is permitted. However, the addition of more than 5 cells in a 20 cell battery contributes to unbalance and it is strongly recommended that users assemble new cells into battery sets and use older surviving cells from rejected batteries to make up complete batteries of older cells. In this way it becomes possible to retire an old battery when cell failures accelerate and not thereby scrap some reasonably new cells.

It is recognized that some USA battery manufactures market rebuilt cells, which are appropriately identified. Because these originate from the original manufacturer, with all that this implies for assurance of performance, they may be considered as 'new' cells. Cells rebuilt by other agencies must not be used as spare units (see Rebuilt Batteries below).

- c) No battery should ever be allowed to rotate through a battery shop without having the 'top of charge' voltage measured for each cell and the manufacturers' pass criteria applied.
- d) Battery room staff should have a method for reporting serious defects so that air safety procedures can be considered. (Significant failures would include burnt cell boxes or signs of arcing at interconnecting links.)
- e) The recording of water addition to batteries should be encouraged and it should be appreciated that a cell with a poor separator tends to use less water than one with a good separator.
- f) Facilities and procedures should exist for regular calibration of temperature sensing devices and wiring should be checked thoroughly as this is particularly vulnerable within batteries.

6 Battery Shops

There has been an upsurge in the range of equipment for charging and testing batteries and some of the equipment does not permit a conventional constant current charging schedule to be applied. For example, one type of equipment now widely used has a charging regime which includes rapid discharge pulses and it is therefore essential that battery workshops' staff have full instructions on the application of such equipment for all the battery types being serviced. These instructions should be officially authorized by a competent engineer and battery history cards should cross reference to the instructions used. Any procedure which does not involve the voltage measurement of every cell is not acceptable. Because of the length of time required to service nickel cadmium batteries, the quantity of work in progress usually demands a considerable working area. This area must be clean and well ventilated and free from an accumulation of scrap batteries.

In no circumstances should the same facilities be used for both nickel-cadmium and lead acid batteries and the ventilation shall be such that no cross contamination can occur.

APPENDIX 1

1 Introduction

1.1 The information provided by this Appendix is set out as follows:

- 2 General Description
- 3 Construction
- 4 Maintenance
 - 4.1 Introduction
 - 4.2 Inspection
 - 4.3 Electrolyte Level and Adjustments
 - 4.4 Battery Cleaning
 - 4.5 Charging of Batteries
 - 4.6 Electrical Leakage Check
 - 4.7 Capacity Test
 - 4.8 Capacity Recycling Procedures
 - 4.9 Cell Balancing
 - 4.10 Voltage Recovery Check
 - 4.11 Insulation Resistance Check
 - 4.12 Cell Removal and Replacement
 - 4.13 Rejected Batteries or Cells
- 5 Installation
- 6 Maintenance of Installed Batteries
- 7 Battery Records
- 8 Storage and Transportation

2 General Description

Nickel-cadmium batteries may be divided into three ranges of basic design, as described below.

- 2.1 **Sealed Batteries.** This range of batteries consists of those having the cells completely sealed. In general the batteries are of small capacity, and may be used for emergency lighting purposes.
- 2.2 **Semi-Sealed Batteries.** The cells in this range of batteries are usually mounted in steel containers and are fitted with safety valves. The batteries may be charged fairly rapidly but are very sensitive to overcharge, thus, for aircraft usage, they are usually fitted with a thermal protective device. Under normal conditions the battery requires practically no maintenance beyond periodic cleaning and capacity checks.
- 2.3 **Semi-Open Batteries.** These batteries are generally used as the main aircraft batteries. The cells are similar in appearance to those of the semi-sealed type, but are deliberately allowed to 'gas' to avoid excessive heating should the battery be on overcharge. The cell cases are usually manufactured from nylon. Because of gassing, the electrolyte has to be 'topped-up' at periods which vary according to the duty cycle of the battery and the conditions under which it is operated. 'Topping-up' periods are specified in the approved Maintenance Schedule for the aircraft concerned (see also Paragraph 4.3).

3 Construction

The plates comprise a sintered base on a nickel-plated steel support. The active materials are nickel hydroxide on the positive plates, and cadmium hydroxide on the negative plates, and these are impregnated into the sintered base by chemical precipitation. This type of plate construction allows the maximum amount of active material to be employed in the electrochemical action.

- 3.1 After impregnation with the active materials, the plates are stamped out to the requisite size. The plates are then sorted into stacks according to the type of cell into which they are to be mounted. Usually there is one additional negative plate for a given number of positive plates. The plates are then welded to connecting pieces carrying the cell terminals, after which a separator is wound between the plates and the insulation is checked under pressure. The plate group is then inserted in the container, the lid secured and pressure-tested for leaks. The separators are usually of the triple-layer type, one layer being made from cellophane film, the other two being woven nylon cloth. Cellophane is used because it has low electrical resistivity and is a good barrier material which contributes to the electrical and mechanical separation of the positive and negative plates, and keeps finely divided metal powder particles from shorting out the plates while still permitting current flow. It also acts as a gas barrier, preventing oxygen given off at the positive plate during overcharge from passing to the negative plate where it would combine with active cadmium, reduce cell voltage, and produce heat as a result of chemical reaction. The cellophane is prone to damage at high operating temperatures, and failure will result in an adverse change in the operating characteristics of a battery (see also Paragraph 4.5.8(a)).
- 3.2 The electrolyte is a solution of potassium hydroxide and distilled water, having a relative density of 1.24 to 1.30. It is impregnated into cells under vacuum, after which the cells are given three formation cycles, re-charged, and then allowed to stand for a minimum period of 21 days. The discharge characteristics at the end of this period enable the cells to be matched.

- 3.3 In a typical battery each component cell is insulated from the others by its moulded plastic case. All the cells are interconnected via links secured to the terminals of the cells, and are contained as a rigid assembly in the battery case. A vent cap assembly is provided on the top of each cell and, in general, is constructed of plastic, and is fitted with an elastomer sleeve valve. The vent cap can be removed for adjustment of the electrolyte level, and acts as a valve to release gas pressure generated during charging. Except when releasing gas, the vent automatically seals the cell to prevent electrolyte spillage and entry of foreign matter into the cell.
- 3.3.1 Two venting outlets, a pair of carry-strap shackles, and a two-pin plug for quick-release connection of the aircraft battery system cables, are embodied in the battery case. A removable cover completes the case, and incorporates a pair of slotted lugs which engage with attachment bolts at the battery stowage location.
- 3.4 **Chemical Principle.** During charging a 'change of ions' takes place; oxygen is removed from the negative plates and is added to the positive plates, bringing them to a higher state of oxidation. These changes continue in both sets of plates for as long as the charging current is applied or until both materials are converted; i.e. all the oxygen is driven out of the negative plates and only metallic cadmium remains, and the positive plates become nickel hydroxide.
- 3.4.1 The electrolyte acts only as an ionized conductor and is forced out of the plates during charging. It does not react with either set of plates in any way, and its relative density remains almost unchanged. Towards the end of the charging process and during overcharging, gassing occurs as a result of electrolysis which reduces only the water content of the electrolyte. Gassing is dependent on the temperature of the electrolyte and the charging voltage (see also Paragraph 4.5.5).
- 3.4.2 During discharge, the chemical action is reversed; the positive plates gradually losing oxygen while the negative plates simultaneously regain lost oxygen. The plates absorb electrolyte to such an extent that it is not visible at the top of the cells.

4 Maintenance

Nickel-cadmium batteries must be prepared for service, charged, tested and otherwise generally maintained, in a well ventilated workshop area which is entirely separate from that used for the servicing of lead-acid batteries. This also applies to servicing and test equipment, tools and protective clothing, all of which should carry some form of identification. Anything associated with lead-acid batteries (acid fumes included) that comes into contact with a nickel-cadmium battery or its electrolyte can cause severe damage to this type of battery.

- 4.1 **Introduction.** Precise details of inspection and maintenance procedures, and the sequence in which they should be carried out, are given in the relevant battery maintenance and overhaul manuals, and other approved supplementary servicing instructions; reference should, therefore, always be made to such documents. The information given in the following paragraphs is intended to serve as a general guide to the procedures to be carried out appropriate to battery service life and condition, and also to the precautions to be observed.
- 4.2 **Inspection.** The following checks are typical of those comprising a battery inspection schedule:
- a) The battery should be identified to establish any known history. If the battery is a new one a servicing record card should be raised (see Paragraph 7).

- b) The outside of the battery case should be examined for evidence of damage, and of locally overheated areas.
 - c) The battery cover should be removed and its rubber lining inspected for condition. Cover latches should operate smoothly and provide proper security of the cover. Extreme care must be exercised when working around the top of a battery with its cover removed. Tools should not be dropped onto the cell connecting links, as severe arcing will result with possible injury to personnel and damage to the battery. Such personal items as rings, metal watch straps and identification bracelets should be removed, to avoid contact with connecting links and terminals.
 - d) There should be no evidence of arcing having occurred between the battery and the aircraft structure. The section near the bottom of the case and the slotted lugs of the cover tie-down strap are areas which are most likely to be affected. If signs of arcing are present, the aircraft battery compartment should be inspected and the battery should be completely dismantled and overhauled.
 - e) The battery should be inspected for signs of electrolyte leakage and should be cleaned where necessary (see Paragraph 4.4).
 - f) The battery receptacle should be checked for evidence of bumps, cracks and bent or pitted terminals. Defective receptacles, which can overheat, cause arcing and depress output voltage, should be replaced.
 - g) All cell links should be checked for security and evidence of overheating, and their terminal nuts should be tightened to the specified torque values. Any cell link showing damage to its plating should be replaced.
 - h) Vent caps should be checked for security and also to ensure that gas exit holes are free from dirt or potassium carbonate crystals. Clogging of vents causes excessive pressures to build up, resulting in cell rupture or distortion of parts. Cell valves, when fitted, should also be checked for security and freedom from dirt or crystal formation. Dirty vent caps or valves should be removed and cleaned (see Paragraph 4.4.3).
- NOTE:** Potassium carbonate is a white crystal formed by the reaction of potassium hydroxide with carbon dioxide in the air; it is non-corrosive, non-toxic and non-irritating.
- i) Temperature sensing devices, when installed, should be checked for secure attachment with leads and connectors showing no signs of chafing or other damage. Electrical checks and/or calibration of these devices should be carried out at the periods specified in the approved Maintenance Schedule.

4.3 **Electrolyte Level and Adjustments.** The level of the electrolyte should, depending on manufacturer's recommendations, only be adjusted when a battery is at the end of charge, while still charging, or after a specified standing time. If electrolyte level adjustments were to be made in the discharged or partially discharged condition, then during a charge electrolyte would be expelled from the cells, resulting in corrosive effects on cell links, current leakage paths between cells and battery case, and a reduction of electrolyte density. The manufacturer's instructions regarding checks on electrolyte level and adjustments should be carefully followed and the maintenance kit equipment designed for a particular type of battery should be used.

NOTE: Adjustments should not be made when batteries are installed in aircraft.

4.3.1 Only the purest water available, preferably pure de-mineralised or distilled water, should be used for adjusting electrolyte levels, and a record of quantity added to all cells should be maintained, because it is largely on this evidence that periods between servicing are determined (see also Paragraph 7). The 'consumable' volume

of electrolyte is normally specified in manufacturer's manuals, but in the absence of such information, a useful guideline is that batteries should not be left for periods which would require the addition of water to any cell by an amount in excess of 1 cc per ampere-hour capacity.

4.3.2 In the event that the electrolyte becomes contaminated, particularly with oil, foaming of the electrolyte will occur. In such cases, a neutralizing fluid, which is available from the relevant battery manufacturer, should be added to the electrolyte, strictly in accordance with the manufacturer's instructions.

4.3.3 Additional potassium hydroxide should not normally be required, but if electrolyte in solution is necessary for topping-up it must be ensured that it is in the proportions specified in the relevant manual.

NOTE: Contamination of the electrolyte with tap water, acids, or other non-compatible substances, will result in poor performance or complete failure of a battery.

4.3.4 Potassium hydroxide should be kept in special containers, and because of its caustic nature, should be handled with extreme care to avoid contamination of the person or clothing. Rubber gloves, a rubber apron and protective goggles should always be worn. If contamination does occur, the affected parts should be immediately rinsed with running water. If available, vinegar, lemon juice or a mild boric acid solution may also be used for treatment of the skin. Immediate medical attention is required if the eyes have been contaminated. As a first-aid precaution, they should be bathed with water or a weak boric acid solution, applied with an eye bath.

4.4 **Battery Cleaning.** Dirt, potassium carbonate crystals, or other contaminating products, can all contribute towards electrical leakage paths (see also Paragraph 4.6) and be a prime cause of unbalanced cells. Cleanliness of batteries is therefore essential.

4.4.1 Deposits should be removed from the tops of cells by using a cloth soaked in de-mineralised or distilled water and a stiff fibre bristle brush. Wire brushes or solvents should not be used. If any contaminating product is caked under and around cell connecting links, the links should be removed, if necessary, to facilitate cleaning. Care should always be taken to ensure that debris is not forced down between cells, and in some cases it may be better to scrape deposits loose and then blow them with low-pressure compressed air. The air itself should be clean and dry, and goggles should be worn to protect the eyes.

4.4.2 Some manufacturers specify periodic flushing of cell tops and battery case with de-mineralised or distilled water while brushing away deposits. This method is not recommended, and batteries in a dirty condition, or showing low resistance, should be dismantled and completely serviced.

4.4.3 When it is necessary to clean vent caps and valves, they should be removed from the cells, using the correct extractor tool, and should be washed in warm water to dissolve any potassium carbonate crystals which may have accumulated within the outlet orifices. They should then be rinsed in de-mineralised or distilled water, dried and re-fitted. Valves should also be tested for correct functioning in accordance with manufacturer's instructions before re-fitting.

NOTE: Cells should not remain open for longer than is necessary.

4.5 **Charging of Batteries.** New nickel-cadmium batteries are normally delivered complete with the correct amount of electrolyte, and in the fully discharged condition. Following a visual check for condition, they must, therefore, be charged in accordance with the manufacturer's instructions before being put into service. Once in service, batteries must then be charged at the periods stated in the approved aircraft

Maintenance Schedule. The following information on charging methods and associated aspects is of a general nature only. Precise details are given in relevant manufacturer's manuals and reference must, therefore, always be made to such documents.

- 4.5.1 **Constant-Current Charging.** This method is the one which should normally be adopted for the workshop charging of batteries, the charging equipment being adjusted and monitored throughout the charging period to supply current at either a single rate, or at several different rates in a stepped sequence. Although more time-consuming than the constant potential method which is often adopted in aircraft battery systems, constant current charging is more effective in maintaining cell balance and capacity. The hour rate of charge current required must be in accordance with that specified by the relevant battery manufacturer.

NOTE: The hour rate of a battery refers to the rate of charge and discharge expressed in multiples of "C" amperes, where "C" is the 1-hour rate. For example, if a battery has a capacity of 23 ampere-hours, then "C" would be 23 amperes and for a 10-hour rate the charge or discharge current rate would be C/10 amperes, i.e. 2.3 amperes.

- 4.5.2 **Vent Caps.** Before charging, the battery cover should be removed, and with the aid of the special wrench provided in the battery maintenance kit, the vent cap of each cell should also be removed.

- 4.5.3 **Connection to Charging Equipment.** Charging equipment should not be switched on until after a battery has been connected and the charging circuit has been checked for correct polarity connections.

- 4.5.4 **Electrolyte Level.** The electrolyte level should be checked and adjusted, as necessary, in accordance with the manufacturer's recommendations (see also Paragraph 4.3).

- 4.5.5 **Gassing.** Gassing of cells occurs within the region of final charge, as a result of the electrolysis of water into hydrogen and oxygen gases. When gases escape from a cell, the quantity of fluid electrolyte is reduced; vigorous prolonged gassing should therefore be avoided. A 'dry' cell is more likely to suffer separator damage, and any cell running hotter than its neighbours should be investigated.

The gassing/temperature phenomena provide a useful indication of impending failure of cells; e.g. a cell that gasses sooner and more actively than its neighbours is going to lose more electrolyte, and as a result will run hotter and tend to dry out. Minor differences in gassing are hard to detect, but large differences should be noted and investigated.

- 4.5.6 **State of Charge.** The state of charge cannot be determined by measurement of the electrolyte relative density or battery voltage. Unlike the lead-acid battery, the relative density of the nickel-cadmium battery electrolyte does not change. Except for 'dead' batteries, voltage measurements at either open circuit or on-load conditions do not vary appreciably with state of charge. The only way to determine the state of charge is to carry out a measured discharge test (see Paragraph 4.7).

- 4.5.7 **Charging of Individual Cells.** Individual cells must be in an upright position and adequately supported at the sides parallel to the plates during charging. A special frame may be built to fit a cell, or boards or plates may be placed on each side and held together with a clamp. After charging and removal from its support, the sides of a cell should be inspected to ensure there are no bumps or bulges which would indicate an internal failure.

NOTE: Cells should always be fully discharged before removal from a battery and before re-assembly.

- 4.5.8 **Thermal Runaway.** In some small aircraft the battery may be charged by constant potential supplied directly from the DC bus-bar. Under correct conditions of temperature and voltage, the internal voltage of the cells rises gradually as the electro-chemical action takes place, and it opposes the charging voltage until this is decreased to a trickle sufficient to balance continuous losses from the cells. The energy supplied to a fully charged battery results in water loss by electrolysis and in heat generation. For a battery in good condition, a point of stability will be reached where heat as a result of trickle current will just balance radiated and conducted heat losses. At low temperatures, a battery will appear to have a limited capacity, and will require more voltage to accept a given amount of charge. As the battery becomes warm, however, its responses return to normal. Operation at high temperatures also limits the capacity, but in such conditions, a battery is subjected to the danger of a 'thermal runaway' condition.
- a) At higher than normal temperatures, the heat loss of the battery through radiation and conduction is lower than the heat generating rate and this results in a higher battery temperature. This, in turn, reduces the internal resistance of the battery, so that higher than normal charge current is admitted resulting in an increase in chemical activity, additional heat and a further increase in charging current. This recurring cycle of temperature rise, resistance and voltage drop, and charge current rise, progressively increases the charging rate until sufficient heat is generated to completely destroy a battery.
 - b) Other factors which can cause overheating of a battery are as follows:
 - i) Voltage regulator of aircraft generating system incorrectly adjusted.
 - ii) Frequent or lengthy engine starts at very high discharge rates.
 - iii) Loose link connections between cells.
 - iv) Leakage currents between a cell and battery container and the airframe structure. Periodic measurement of leakage current and removal of any electrolyte that may have accumulated around and between cells should be carried out to prevent high leakage and short circuits from developing (see also Paragraph 4.6).
 - v) Use of unregulated, or poorly regulated, ground support equipment to charge a battery, particularly a battery which has become hot as a result of excessive engine cranking or an aborted engine start.
 - vi) High initial charging currents imposed on a hot battery.
 - vii) Unbalanced cells. Cell unbalance (see Paragraph 4.9) refers to an apparent loss of capacity and to variations in cell voltage at the end of charging cycles. These variations can develop over a period of time, particularly when subjected to operating conditions like those occurring in aircraft utilising charging circuits of the constant potential type. Other factors which may also contribute to cell unbalance are cell position in the battery, e.g. centre cells run warmer than outer cells, and the self-discharge of individual cells.
 - c) In some types of aircraft, the batteries specified for use incorporate a thermostat type detector which illuminates a warning light at a pre-set temperature condition. In addition, a thermistor type sensing network may also be incorporated. The network operates in conjunction with a special solid-state, pulse-charging unit, and its function is to monitor the charging current and to de-energize the charging circuit when the battery temperature exceeds a safe operating limit. Detection devices should be checked at the periods stated in the approved aircraft

Maintenance Schedule and in accordance with the relevant manufacturer's instructions.

4.6 **Electrical Leakage Check.** Electrical leakage refers to current flowing in a path other than that desired, and in connection with batteries, this means current between the terminals or connectors of cells and any exposed metal on the battery case. The only pertinent measure of leakage of importance to a cell is the rate of discharge caused by the leakage, and this is only significant when its value approaches that specified for the particular type of battery. In one type for example, a leakage of up to 0.020 amps is quoted as the permissible value. Typical methods of determining electrical leakage are described below.

4.6.1 The positive lead from the terminal of a multi-range testmeter should be connected to the positive terminal of the battery and, after selecting the appropriate scale range (usually the one amp. range) the negative terminal lead from the testmeter should be touched on any exposed metal of the battery case. If a pointer deflection is obtained it will denote a leakage and the testmeter scale setting should be adjusted, if necessary, to obtain an accurate reading which should be within the limits specified.

The foregoing check should be repeated between the battery negative terminal and battery case, when again any readings obtained should be within limits. If either of the readings obtained exceed the specified limits the battery should be thoroughly cleaned (see Paragraph 4.4) and the checks again repeated.

4.6.2 If, after thorough cleaning, the leakage current is in excess of the limits it is probable that one of the cells is leaking electrolyte and is therefore defective. This cell may be found by measuring the voltage between each cell connecting link and the battery case. The lowest voltage will be indicated at the connecting links on each side of the defective cell which should be replaced (see also Paragraph 4.12).

4.7 **Capacity Test.** The capacity or state-of-charge of a fully-charged battery is checked by discharging it at a specified rate (preferably automatically controlled) after it has been standing for a certain time period, and noting the time taken for it to reach a specified on-load voltage. For example, a 23 ampere-hour battery is left to stand for 15 to 24 hours and is then discharged at 23 amperes, i.e. the 1-hour rate, to 20 volts. A battery should give at least 80% of the capacity specified on its nameplate, or the minimum authorised design capacity, whichever is the greater.

NOTE: Some batteries of U.S. origin have initial capacity ratings which are significantly higher than those specified on their nameplates. When the nameplate ratings are no longer obtainable such batteries are rejected.

4.7.1 True capacity must always be recorded, meaning that a full discharge is required, and not one which is terminated when the minimum acceptable level has been reached. Because it is essential to monitor a number of cell voltages very closely, the service of two persons is desirable towards the end of discharge for measurement and recording. At this stage, voltages fall very quickly, and it is highly desirable that measurements be made with a digital voltmeter.

NOTE: No cell should be allowed to go into reverse polarity before the measured discharge is complete, and the terminal voltage should not go below 1 volt per cell, since excessive gassing may result.

4.8 **Capacity Recycling Procedures.** The purpose of recycling is to restore a battery to its full capability and to prevent premature damage and failure. The discharge rates and voltage values appropriate to the recycling procedures vary between types of battery, and reference should always be made to the relevant manual. The figures quoted below are typical, and serve only as a guide to the limits normally specified.

- 4.8.1 The battery should be discharged at a current equal to or less than the one-hour rate, and as each cell drops below 0.5 volts (measured by a digital voltmeter) it should be shorted out by means of a shorting strip. The cells should remain in this condition for a minimum period of 16 hours, preferably 24 hours.
- NOTE:** A battery should not be discharged at an excessively high rate and cells then short-circuited since this produces severe arcing and excessive heat generation.
- 4.8.2 The shorting strips should then be removed, and the battery charged for 24 hours at the specified recycling charging rate. After approximately five minutes of charge, individual cell voltages should be measured and if any cell voltage is greater than 1.50 volts, distilled water should be added. The amount of water required depends on the rated ampere-hour capacity; a typical maximum value is approximately 1 cc per rated ampere-hour.
- 4.8.3 After approximately 10 minutes of charge, individual cell voltages should again be measured. Any cell measuring below 1.20 volts or above 1.55 volts should be rejected and replaced.
- 4.8.4 After 20 hours of charging, individual cell voltages should be measured and recorded, and, if necessary, distilled water should be added to the normal level appropriate to the type of battery.
- 4.8.5 At the end of the 24 hours charge period, cell voltages should again be measured and compared with those obtained after 20 hours. If the 24 hour voltage reading is below the 20 hour reading by more than 0.04 volts, the cell concerned should be rejected and replaced.
- 4.9 **Cell Balancing.** If a battery fails to give 80% capacity on test, and if premature ageing of some cells is suspected, a cell balancing test should be carried out. The procedure for carrying out the test appropriate to a particular type of battery is prescribed in the relevant manual, and reference should always be made to such document. The following details, based on the test specified for a typical 23 ampere-hour battery, are given only as a general guide.
- 4.9.1 Note the time, and discharge the battery at 23 amperes until the terminal on-load voltage falls to 20 volts, then stop the discharge. During the discharge, the voltage of each cell should be frequently checked with a digital voltmeter. A zero reading early in the discharge indicates a short circuit cell; a reverse reading indicates a weak cell. In either case the discharge should be stopped, even if the overall battery voltage has not yet fallen to 20 volts. The weak or faulty cell should be shorted out, preferably through a 1 ohm resistor.
- 4.9.2 Note the time and recommence the discharge at the lower rate of 2.3 amperes. Frequently check the voltage of the cells and short out each cell (with individual shorting strips) as it falls below 1 volt. Record the lapsed time of discharge for the cell to fall below 1 volt, thereby obtaining an indication of the relative efficiency of the cells.
- Some manufacturers specify 0.5 volts as the point at which shorting of the cells should be carried out. This is satisfactory providing that sufficient time is available to permit shorting of all cells before any are subjected to reverse voltage resulting from the charging effect of stronger cells.
- 4.9.3 The discharge should be stopped when all the cells are shorted out. The battery should be left in this condition, and also with the main terminals shorted together, for as long as possible, but never less than 16 hours.

- 4.9.4 The battery should then be charged and the cell-balancing procedure repeated. The discharge times recorded for each cell to fall below 1 volt should show an improvement over those previously recorded.
- 4.9.5 Weak and internally short-circuited cells should be replaced in accordance with the instructions detailed in the relevant battery Maintenance Manual (see also Paragraph 4.12).
- 4.10 **Voltage Recovery Check.** This check, which should be made at a given time after shorting strips have been removed from the cells or main battery terminals, provides a ready means of detecting high resistance short-circuits and damaged connections within a battery. A typical procedure for this check is given below.
- 1 Shorting strips of one ohm resistance should be connected between cells, and the battery should be allowed to stand for 16 to 17 hours. At the end of this period, the voltage of individual cells should be measured to ensure that they do not exceed the minimum value specified for the battery (a typical minimum value is 0.20 volts).
 - 2 The shorting strips should then be removed, and after a further standing period of 24 hours, individual cell voltages should again be measured to check their recovery to within normal operating values. A typical minimum value specified as a basis for rejection of a cell is 1.08 volts.
- 4.11 **Insulation Resistance Test.** A test for insulation resistance may be specified by some manufacturers as the means of checking for electrical leakage. Reference should, therefore, be made to the appropriate maintenance manual for the procedure to be adopted, for permissible values, and for any remedial action to be taken.
- 4.12 **Cell Removal and Replacement.** Cells should be removed from a battery whenever they are suspected of leakage of electrolyte, internal short-circuits, when they fail to balance (see also Paragraph 4.9) or if the insulation resistance is found to be below the value specified for the particular battery. The method of removing and replacing cells may vary between types of battery, and the instructions issued by the relevant manufacturers must, therefore, always be carefully followed. The information given below, although based on a specific type of battery, is intended to serve only as a guide to the practical aspects generally involved.
- 4.12.1 The battery should be discharged and the cell links disconnected and removed both from the faulty cell and from the adjoining cells. The cell position should be noted for subsequent entry in the battery record card.
- 4.12.2 The vent cap should be loosened using the special key provided with the battery maintenance kit.
- 4.12.3 A cell extractor tool should then be fitted to the cell on the terminals normally used for connecting the cell links. The battery is then held firmly and the cell withdrawn vertically upwards without using undue force. When one cell is removed and all other cell links are disconnected, it is relatively simple to withdraw the remaining cells without the aid of the extractor.
- NOTE:** After removing a cell, its vent cap should be retightened.
- 4.12.4 Cells and the inside of the battery case should be thoroughly cleaned and dried (see Paragraph 4.4).
- 4.12.5 After carrying out all necessary checks, serviceable cells should be replaced in the battery case in their correct positions, and a cell-to-cell voltage check should be

carried out to ensure that polarities are not reversed. It must be ensured that any new cells are of the same manufacture, part number, and are of matched capacity rating.

NOTE: A steady force should be used on terminals to press cells into place. Tight cells should not be hammered into place. For easiest assembly, the cell at the middle of a row should be inserted last.

- 4.12.6 The surfaces of cell terminals and connecting links should be clean, and, after ensuring the correct positioning of links, terminal nuts should be tightened to the specified torque value, and in a sequence commencing from the battery positive terminal. Care should always be taken to ensure that nuts actually tighten the connector assemblies, and are not binding as a result of thread damage or bottoming.

NOTE: Once a tightening sequence has been started it should be completed, thereby ensuring that a nut has not been overlooked. One loose connection can permanently damage a battery and may cause an explosion.

- 4.12.7 On completion of cell replacement procedures, the battery should be re-charged, tested for insulation resistance, and, if any new cells have been fitted, a capacity test should also be carried out.

- 4.13 **Rejected Batteries or Cells.** Any batteries or cells which are rejected should be conspicuously and permanently marked on their cases to indicate that they are to be used only for general ground use.

5 Installation

It should be ensured that the battery is of the correct ampere-hour rating, fully charged, and that the electrolyte is at the correct level. Depending on the service history of the battery, appropriate tests, e.g. capacity test, capacity recycling and cell balancing, must also have been carried out in the manner prescribed for the particular battery. Reference should be made to the relevant aircraft Maintenance Manual for details of the battery system and associated installation instructions. Before coupling the system connecting plug, a check should be made to ensure that the battery system switch is OFF, and that all electrical services are isolated.

NOTE: Batteries are heavy units, and they require the use of approved handling methods to prevent possible injury to personnel and damage to the cases or components adjacent to the battery location. Vent pipes should not be used for lifting purposes.

- 5.1 The battery compartment should be thoroughly clean and dry, and the battery should be securely attached in its mounting. Clamp nuts should not be over-tightened since distortion of the battery cover may result, which could affect the venting arrangements.

NOTE: If a battery compartment has been previously used for lead-acid batteries, it should be washed out with an acid neutralising agent, dried thoroughly, and painted with an alkaline-resistant paint.

- 5.2 The supply cables from the battery, and, where appropriate, thermostat and battery charging system cables, should be checked for signs of chafing or other damage. Cable connecting plugs should be securely made, without any strain on the plugs or cables.

- 5.3 Battery installations are normally designed so that in flight, sufficient air is passed through the compartment to dilute the hydrogen gas given off by a battery, to a safe level. Ventilation systems should therefore be checked to ensure there is no

obstruction or, if integral venting is used, the connections should be checked for security and leaks.

NOTE: In some ventilation systems, non-return valves are incorporated in the battery compartment vent lines. These valves should also be checked for security and correct location.

- 5.4 After installation, a check should be made that the electrical connections of the battery supply cables have been correctly secured by switching on some electrical services for a specific time period and noting that readings of the aircraft voltmeter remain steady. A typical load and time is 30 amperes for 30 seconds. For battery systems having a separate 'in situ' charging unit, the unit should be switched on and its electrical settings checked to ensure proper charging of the battery.

6 Maintenance of Installed Batteries

Batteries should be inspected at the periods specified in the approved aircraft Maintenance Schedule. The details given below serve as a general guide to the checks normally required.

- 6.1 The battery mounting should be checked for security, and the outside of the battery case should be examined for signs of damage and for evidence of locally overheated areas. The latches of the cover should operate smoothly and should firmly secure the cover in position.

Connecting plugs of the battery receptacle, thermostat and battery charger units, where fitted, should be checked for signs of contamination, burns, cracks, and bent or pitted terminal fittings.

- 6.2 The tops of all cells and vent caps should be inspected for signs of electrolyte leakages and should be cleaned where necessary.

- 6.3 The electrolyte level should be checked, and if any adjustments are necessary, these should be made after removing the battery from the aircraft and checking that it is in the fully charged condition. The amount of water added to the cells should be noted on the battery record card. A cell requiring more than the specified amount should be regarded as suspect, and the battery should be replaced by a serviceable unit. In aircraft having an independent charging unit, the unit should be switched on and the battery charged in accordance with the procedure specified in the relevant aircraft Maintenance Manual.

NOTE: When removed, the battery cover and cell vent caps should not be placed on any part of the aircraft structure or equipment.

- 6.4 The battery ventilation system should be checked to ensure security of connection, and freedom from obstruction.

7 Battery Records

A technical or service record should be maintained on each battery in service. Discretion may be exercised as to the layout of such a record and the extent of the details it should contain. It should, however, provide a fairly comprehensive history of the specific battery, so that in the event of a malfunction it will assist in establishing the fault. The example shown in Figure 1 is intended only as a guide.

8 Storage and Transportation

Nickel-cadmium batteries should be stored in a clean, dry, well-ventilated area and should be completely segregated from lead-acid batteries. The area should also be free from corrosive liquids or gases. It is recommended that they should be stored in the condition in which they are normally received from the manufacturer, i.e. filled with electrolyte, discharged and with shorting strips fitted across receptacle pins. Cell connecting strips and terminals should be given a coating of acid-free petroleum jelly (e.g. white vaseline).

- 8.1 The temperatures at which batteries may be stored are quoted in the relevant manuals, and reference should therefore be made to these. In general, a temperature of 20°C is recommended for long-term storage.
- 8.2 If batteries are to be stored in a charged condition, they must be trickle charged periodically in order to balance the inherent self-discharge characteristic. Since this discharge is temperature sensitive, the trickle charge rate is therefore dependent on the storage temperature conditions.
- 8.3 If it is necessary to return a battery to the manufacturer or to an approved overhaul organisation, it should be discharged, but not drained of electrolyte. It should be packed in its original container, together with its service record (see Paragraph 7) and 'This Way Up' international signs affixed to the outside.

NOTE: If transportation is to be by air, the container must comply with IATA regulations concerning the carriage of batteries containing alkaline electrolyte.

NICKEL-CADMIUM BATTERY SERVICE RECORD

BATTERY AND AIRCRAFT DATA

Manufacturer Aircraft Type:
 Part No Registration
 Serial No Battery Function (e.g. Standby, APU Starting)
 Rating: Volts Ah.....
 Mod. State Date Installed
 Hours Flown

SERVICING DATA

Date Removed Reason for Removal
 Date Serviced Servicing Instructions Used
 Workshop Ambient Temp Date Released

Operation	Results/Comments	Initials	
		Mech	Insp
Details of operations performed and measurements required			

CELL DATA

Position in Battery	Serial No	Water Added (c.c.)	Voltage	Temperature	Final Voltage	Capacity (Ah)
1						
2						
**						
19						
20						

MAIN TERMINAL VOLTAGE

[Insert release to service statement as given in Part M, AMC M.A.801, Part 145, AMC 145.A.50(b) or BCAR A6-2, paragraph 8, as appropriate.]

Signed:

Firm

**EASA/UK 145 Approval Ref.
 or UK MF Approval Ref.**

Date

Figure 1

Leaflet 24-30 Electrical Generation Systems – Multi-Engined Aircraft not Exceeding 5700 kg Maximum Authorised Weight

1 Document Scope

This CAA Leaflet was originally written to give guidance for compliance with CAA Airworthiness Notice (AN) No. 82. This AN has been notified to the European Aviation Safety Agency (EASA) under Article 14.1 of Regulation (EC) 216/2008, and therefore the content is still appropriate. AN No. 82 has been transferred to CAP 747, Mandatory Requirements for Airworthiness, Appendix 1, as Generic Requirement (GR) No. 4. These GRs are pending EASA review and concurrence. The resulting EASA Policy will supersede the validity of this Leaflet.

NOTE: CAA ANs that are notified to EASA have been transferred to CAP 747, Mandatory Requirements for Airworthiness, Appendix 1 as Generic Requirements. CAP 747 provides a single point of reference for all mandatory information for continuing airworthiness, including Airworthiness Directives, as applicable to civil aircraft registered in the UK.

The technical content and the paragraph numbering of GR No. 4 is identical to that of AN No. 82, issue 2, dated 29 October 2001. Therefore, the guidance given in this Leaflet is also valid for GR No. 4. This Leaflet has been updated to reflect the changes in requirement references.

2 Purpose

The purpose of this Leaflet is to provide guidance information for achieving compliance with CAP 747 GR No. 4, which requires that all multi-engine aircraft not exceeding 5700 kg maximum authorised weight are provided with:

- a) clear visual warning of failures of the electrical generating system,
- b) at least 30 minutes duration on the battery, for the provision of power to certain equipments under such failures, and
- c) precise crew drills to cover these conditions.

For precise details and the applicability of the requirements reference should be made to CAP 747 GR No. 4.

NOTE: Although GR No. 4 does not apply to single engined aircraft the CAA reminds owners and operators of such aircraft of GR No. 6. This addresses the installation of generator/alternator failure or low bus voltage warning lights under the minor modification procedure.

3 References

CAP 747 Mandatory Requirements for Airworthiness, Generic Requirements (GRs) No. 4, dated 30 November 2009.

4 Introduction

This Leaflet gives general guidance on:

- a) The introduction of the failure indication. Reference GR No. 4 paragraph 2.2.
- b) The preparation of evidence in support of the required battery endurance, Reference GR No. 4 paragraph 2.3, including a number of assumptions or approximations which are intended to help readers to determine numerical answers and reach conclusions with an acceptable degree of accuracy.
- c) The preparation of crew drills. Reference GR No. 4 paragraph 2.5.

NOTE: Aircraft that are not fitted with vacuum instrument supplies and have only electrically powered attitude reference instruments (i.e. Bank and Pitch and Turn and Slip Indicators) must be the subject of a detailed design investigation to establish compliance with GR No. 4 paragraphs 2.4 and 2.4.1. Such aircraft are in a minority and outside the terms of this Leaflet.

5 Generator Failure Detection

Basically there are three acceptable methods of detecting generation system failures, the objective of each being to alert the pilot to an abnormal state by the operation of warning lights. They are as follows:

a) Generator Output Detection

The most positive method is to detect the output from each generator/alternator as close to the bus bar system as possible, because this ensures not only that the generator/alternator is supplying an output but that there is no break in the cabling or associated control equipment between it and the bus. However a reverse current blocking system is required such as a diode or reverse current relay, in order to isolate the generators from the battery, and this may not be provided on the aircraft as basic equipment.

b) Alternator Auxiliary Output

Certain alternators have an auxiliary output terminal which when connected to a suitable voltage detector or relay can be made to operate a failure warning light. This system has the advantage of separate warning lights for each alternator although it cannot detect failures of cable connections or equipment between the alternator and bus bar.

c) Low Bus Voltage Detection

This comprises a voltage level detector connected to the main distribution bus which illuminates a warning light should the battery commence to supply the bus system. Several detector systems are available as compact items which include voltage detector and warning light in a single unit and usually only operate when both generators/alternators have failed.

Other methods of generator/alternator failure are feasible but not covered within the context of this Leaflet.

6 Location of Warning Lights

The warning lights should be located as close to the pilot's normal scan of vision as possible in any reasonable position on the left or centre instrument panels where they will not be obscured. They must be coloured red and undimmable. Exceptions to these rules may be made in certain circumstances by agreement with the CAA Airworthiness Evaluation and Surveillance Department. Should any operator wish to fit a flashing red light, in accordance with paragraph 2.3 of GR No. 4 then the flashing characteristic must be cancellable after the pilot has taken action in order to eliminate annoyance especially during night flying.

7 Battery Load Analysis

In order to prove compliance with GR No. 4 paragraph 2.3 which requires a battery duration of not less than thirty minutes should the generation system fail, it is necessary either to carry out a practical test or to calculate the battery endurance when supplying certain specified systems or equipments.

7.1 **By Practical Test.** This could be carried out on the ground or in the air by simulating the failure and subsequent drills in accordance with an agreed schedule, which must be based on the battery voltage not falling below that stipulated in GR No. 4 paragraph 3.1.1. The actual state of charge and capacity of the battery must also be known before commencing the tests. The main problem with a ground test is that 'dummy' electrical loads will be necessary to simulate such apparatus as pitot heads that cannot be operated continuously on the ground. An air test could lead to a dangerous situation if the battery became flattened below the voltage stipulated in GR No. 4 paragraph 3.1 and the generation system could not be restored. If an operator wishes to carry out either of these tests reference should be made to the CAA Airworthiness Evaluation and Surveillance Department to ensure that the proposed procedures are acceptable unless they have been agreed previously for a similar aircraft.

7.2 **By Calculation.** An accurate theoretical assessment of the battery performance requires a load analysis to be compiled and the discharge figures checked against the battery manufacturers discharge curves and data sheets.

Because the full battery data may not be available, a simplified load analysis format together with guidance on the necessary calculations is shown on Appendix 1 of this Leaflet.

The battery being a source of stored electrical power will during its life gradually lose its ability to retain this energy, and for this reason a stipulation is made that only 72% of the name plate rating may be considered as available. This figure is an approximation on the basis that when in service batteries are typically only 90% charged and may be retained on the aircraft down to 80% of the name plate capacity.

The capacity of a battery is:

Rate of Discharge (amps) x Time to Discharge

normally expressed in ampere hours but for load analysis calculations it is almost invariably expressed in amp-mins for convenience (i.e. amp-hours x 60). However this is not a linear function for with heavier discharge currents the discharge time decreases more rapidly so that the power available is less (i.e. reduced efficiency).

For Example – When discharging a 25 ampere hour battery down to 21.6 volts it may give:

150 amps for 5 mins	=	750 amp-mins
45 amps for 20 mins	=	900 amp-mins
18 amps for 1 hour	=	1080 amp-mins
10 amps for 2 hours	=	1200 amp-mins
5 amps for 5 hours	=	1500 amp-mins

Therefore in order to make an accurate assessment of battery duration, reference should be made to the manufacturers discharge curves. However it is recognized that these may not be available and certain assumptions and approximations are given in the following text to overcome this difficulty.

Because of this problem of definition of capacity it is first necessary to ensure that all calculations are based on the 1 hour rate. Some manufacturers however do not give this on the name plate and quote a 5 hour rate. For these calculations as a 'rule of thumb' it may be assumed that the 1 hour rate is 85% of the quoted 5 hour rate.

Following the generator system failure and before the pilot has completed the load shedding drills the battery may be subjected to high discharge currents with a resultant loss of efficiency and capacity on the principle explained in the previous paragraph. To make allowance for such losses the calculated power consumed during the pre-load shed period should be factored by an additional 20% if the average discharge current in amps is numerically more than twice the 1 hour rating of the battery.

When compiling this load analysis all electrical services operating during a normal night cruise pre-load shed period should be listed. De-icing loads, for example, need not be included.

The minimum equipments to be retained after load sheet are given in paragraph 3.1 of GR No. 4. However it may not be possible to switch off all of the unwanted services due to duplication of services on circuit breakers, lack of switches or inaccessibility of fuses, and in such cases these loads must also be listed in the electrical load analysis.

It is the operator's choice whether to have the minimum services operating for a period longer than the thirty minute minimum or to have the maximum services available to meet the required duration.

Should the determined battery duration be less than the required thirty minutes it is recommended that the operator should seek advice from the CAA Airworthiness Evaluation and Surveillance Department before considering the fitment of larger batteries in the aircraft in order to verify the load shedding procedures being proposed. Further, as the calculations are known to be based on conservative approximations CAA may accept up to 3 minutes short on the calculated battery endurance.

Although some aircraft are equipped with generator/alternator failure lights in accordance with paragraph 2.2 of GR No. 4, it is still necessary to ensure that the Flight Manual or Pilots Notes include the necessary drills and battery duration times as required by paragraphs 2.3 and 2.4. Where the requirements are not met it is the responsibility of the owners or operators to prepare and submit the necessary documentation.

- 7.3 **Crew Drill.** An example of the wording for the crew drill is shown on Appendix 2 attached. This format is recommended in order to help reduce the workload on all concerned in the preparation of the appropriate manuals.

APPENDIX 1 Sheet 1

Battery Capacity Analysis

Modification No

BH001

Sheet 1 of 1

Aircraft type A.R.BEE

Registration

G-CAA

Battery type AIRDIV AD 1 Capacity 20 AH (1 hour rate) 24 volts

(Lead acid/Ni-Cadmium)

1	2	3	4	5	6	7	8
Equipment	No. Fitted	Load per Unit (amps)	Time on (mins)	Pre-Load Shed Power Consumed 5/10 min Period. (amp-mins)	Remaining Cruise Load After Load Shed (amps)	Landing Power Consumed 5 mins Period. (amp-mins)	Notes
Internal Lights	2	.5	Int	5.0	.5	2.5	
Instrument Lights	1 set	2.0	Cont	20.0	2.0	10.0	
Nav. Lights	1 set	4.0	Cont	40.0	-	-	
Anti-Collision Beacons	2	2.0	Cont	40.0	-	-	
Pitot Heater	1	3.0	Cont	30.0	-	-	
Fuel Pumps	2	2.0	Int	-	-	20.0	
Engine Instruments	1 set	3.0	Cont	30.0	3.0	15.0	
Warn Lights	1 set	1.0	Int	10.0	1.0	5.0	
Inverter	1	6.0	Cont	60.0	-	-	
De Mist Fan	1	2.0	Int	-	-	-	
VHF Comm 1	1	REC 4.0 TX	Cont	10.0	1.0	5.0	
VHF Comm 2	1	1.0 REC 4.0 TX	Cont	10.0	-	-	
ADF	2	1.0	Cont	20.0	-	-	
VHF NAV	1	1.0	Cont	10.0	1.0	5.0	
Audio	1	1.0	Cont	10.0	-	-	
Radar	1	10.0	Cont	100.0	-	-	
Turn & Slip	2	.5	Cont	5.0	.5	2.5	
Land. Light	2	10.0	Int	-	-	20.0	
U/C Operation	1	6.0	Int	-	-	3.0	
U/C Warning	1	.5	Int	-	-	2.5	
	TOTALS			400	9.0	90.5	

Duration of Flight on Battery = 52 Minutes

For calculations see sheet 2

APPENDIX 1 Sheet 2**DATA**

a) Battery rated capacity (1 hour rate) 20	amp-hours
b) Battery capacity available (a x 72%) 14.4	amp-hours
 864	amp-mins
c) Pre-load shed power consumed 400	amp-mins
d) Pre-load shed power consumed correct for battery efficiency (c x 1.20) 480	amp-mins (See note (v))
e) Cruise load night 9.0	amps
f) Landing power consumed 90.5	amp-mins

CALCULATION

$$\text{Cruise duration} = \frac{b-(d+f) \text{ amp min}}{e \text{ amp}} = \frac{864 - (480 + 90.5)}{9}$$

$$= \dots\dots\mathbf{32.6}\dots\dots \text{ mins}$$

Duration of battery

= pre-load shed time + cruise duration + landing time

$$= \dots\dots\mathbf{47.6}\dots\dots \text{ mins}$$

APPENDIX 1 Sheet 3

NOTES:

- 1 Battery capacity shall be such that in the event of a complete loss of generated electrical power, adequate power will be available for a period of not less than 30 minutes following the failure and be capable of supporting those services essential to the continued safe flight and landing of the aircraft. This includes the pre-load shed period of 10 minutes (or 5 minutes) from operation of a failure warning for completion of the appropriate crew drills (see CAA CAP 747 GR No. 4 paragraph 2.3).
- 2 For the purpose of calculating the battery endurance:
 - i) Only normal night cruise loads need be considered (e.g. it can be assumed that de-icing loads are not applied at the time of failure).
 - ii) Landing period is assumed to be 5 minutes.
 - iii) Cruise duration =

$$\frac{\text{b) Battery capacity} - \text{(Pre-load shed and landing loads)}}{\text{c) Cruise load}}$$
 - d) \times e)
 - f) =
 - iv) Battery capacity available = 72% of nominal rated capacity (80% of nameplate rated capacity at 1 hour rate and 90% state of charge). Capacity at 1 hour rate = 85% of 5 hour rate.
 - v) Pre-load shed power consumed – if this figure is more than twice the battery rating in amps (1 hour rate) a factor of 20% must be added to the power consumed to compensate for loss of battery efficiency under these heavy discharge loads.
 - vi) Consideration must be given to any loads that cannot be switched off.
- 3 If compliance with the 30 minute operational period depends on certain equipment being switched off, the nominated minimum required equipment must be detailed in the aircraft Flight Manual or equivalent document.

Where duration permits only limited use or 'one-shot' operation of equipment (e.g. flaps, landing gear) such restrictions and suitable operating instructions must be shown in the aircraft Flight Manual or equivalent document.

APPENDIX 2 Sheet 1

(Example Only)

FLIGHT MANUAL SUPPLEMENT DATA

CAA CAP 747 GR No. 4

Aircraft type A R BEE
Aircraft Registration G-CAA
Aircraft Serial No. 001
Supplement to Flight Manual FM2/74

This supplement is required in accordance with the requirements of CAA CAP 747 GR No. 4 paragraphs 2.3, 2.4, and 2.5.

Paragraph 2.3

Duration of batteries following total generation system failure.

Night -52..... mins

Paragraph 2.4

The attitude indicator installed in the left-hand instrument panel is vacuum operated. In the event of total generation system failure reference can be made to this instrument.

Example only – when low bus volts warning is fitted.

Paragraph 2.5

Crew Drills**Pre Flight Check**

Before engine start

Gen/Alt 1 and 2 - Off

Battery - On

Low volts warn light - On

After engine start

Gen/Alt 1 or 2 - On

Battery - On

Low volts warn light - Out

APPENDIX 2 Sheet 2

Emergency Procedure

Low volts warn light - On

Check Gen/Alt 1 and 2 ammeters - Zero

If both read zero –

Switch off all electrical service except the following:

Internal Lights

Instrument Lights

Engine Instruments

Warning Lights

VHF COMM No. 1

VHF NAV

Turn and Slip Indicator
(Pilot)

Landing Light

Undercarriage Operation

Undercarriage Warning

NOTE:

- a) A landing should be made as soon as possible but under the generation failure conditions the battery endurance should be 52 mins.
- b) VHF communication transmission should be restricted to maximum of 3 minutes during total flight.
- c) Other electrical services may be used at the pilots discretion but the battery endurance will be reduced pro rata.

Prepared by

CAA Surveyor

Date

INTENTIONALLY LEFT BLANK

Leaflet 24-40 Aircraft Electrical Load and Power Source Capacity Analysis

1 Purpose

The purpose of this Leaflet is to provide guidance material on the preparation of an Electrical Load and Power Source Capacity Analysis as required by Civil Aviation Requirements.

2 References

2.1 Applicable Certification Specifications and Acceptable Means of Compliance

The following references to Certification Specifications (CS) and Acceptable Means of Compliance (AMC) are for guidance purposes only. The applicable Certification Specifications will depend upon the type of aircraft for which the Electrical Load Analysis (ELA) is to be compiled. Although CS-25 has been referenced for large public transport aircraft, similar requirements are contained in CS-VLA and 23 for smaller aircraft and CS-VLR, 27 and 29 for Rotorcraft.

CS 25.1165 (b)	Engine Ignition Systems
CS 25.1310 (a), (b)	Power source capacity and distribution
CS 25.1351 (a), (b), (d)	Electrical Systems and Equipment – General
CS 25.1355 (b)(6)	Distribution System
CS 25.1585	Operating procedures
AMC 25.1351 (d)	
AMC-20	General Acceptable Means of Compliance for Airworthiness of Products, Parts and Appliances.

2.2 Historical References

British Civil Airworthiness Requirements – Section J (Electrical) (CAP 466)
Military Specification MIL-E-7016F (Electric Load and Power Source Capacity, Aircraft, Analysis of).

2.3 Other References

EUROCAE ED-14, RTCA DO-160 () (Latest Issue) 'Environmental Conditions and Test Procedures for Airborne Equipment' Section 16 (Power Input).

3 Introduction

3.1 In order to show compliance to CS 25.1351 (a) (CS-25 Certification Specifications at 17 October 2003), a determination has to be made of the electrical system capacity, which is typically demonstrated by the compilation and submission of an 'Electrical Load Analysis'.

CS 25.1351(a)(17 October 2003)

"a) *Electrical system capacity.* The required generating capacity, and number and kinds of power sources must -

- 1 Be determined by an electrical load analysis; and

2 Meet the requirements of CS 25.1309. "

NOTE: The above Certification Specification is for CS-25 (Large Aeroplanes), however this requirement is similar to that contained in other CS Certification Specifications such as CS-23.

3.2 The main purpose of the Electrical Load Analysis (ELA) and Power Source Capacity analysis is to estimate the system capacity (including generating sources, converters, contactors, busbars etc.) needed to supply the worst-case combinations of electrical loads. This is achieved by evaluating the average demand and maximum demands under all of the applicable flight conditions.

3.3 A summary can then be used to relate the ELA to the system capacity and can establish the adequacy of the power sources under normal, abnormal and emergency conditions.

NOTE: It is important to note that the Electrical Load Analysis is a 'living' document and as such should be maintained throughout the life of the aircraft to record changes to the connected loads, which may be added or removed by modification.

3.4 The Electrical Load Analysis that is produced for Aircraft Type Certification should be used as the baseline document for any subsequent changes. If possible, the basic format for the ELA should be maintained to ensure consistency in the methodology and approach.

3.5 In some cases, the original ELA may be lacking in certain information, for instance, 'time available on emergency battery', and as such, it may be necessary to update the ELA using the guidance material contained in this Leaflet.

4 Electrical Load Analysis - Basic Principles

4.1 The principle of an Electrical Load Analysis demands the listing of each item or circuit of electrically powered equipment and the associated power requirement. The power requirement for a piece of equipment or circuit may have several values depending on the utilisation for each phase of aircraft operation.

4.2 In order to arrive at an overall evaluation of electrical power requirement, it is necessary to give adequate consideration to transient demand requirements which are of orders of magnitude or duration to impair system voltage and/or frequency stability, or to exceed short-time ratings of power sources (i.e. intermittent/momentary and cyclic loads). This is essential, since the ultimate use of an aircraft's ELA is for the proper selection of characteristics and capacity of power-source components and resulting assurance of satisfactory performance of equipment, under normal, abnormal and emergency operating power conditions.

5 Content of Electrical Load Analysis

The Load and Power Source Capacity Analysis report should include sections as follows:

- a) Introduction
- b) Assumptions and Criteria
- c) AC and DC Load Analysis – Tabulation of Values
- d) Emergency and Standby Power Operation
- e) Summary and Conclusions

a) Introduction

It is suggested that the introduction to the 'Load and Power Source Capacity Analysis' report include the following information in order to assist the reader in understanding the function of the electrical system with respect to the operational aspects of the aircraft.

Typically, the introduction to the ELA would contain details of the following:

- i) Brief description of aircraft type, which may also include the expected operating role for the aircraft;
- ii) Electrical system operation, which describes primary and secondary power sources, bus configuration with circuit breakers and connected loads for each bus. A copy of the bus wiring diagram or electrical schematic should also be considered for inclusion in the report;
- iii) Generator and other power source description and related data (including such items as battery discharge curves, TRU, Inverter, APU, Ram Air Turbine, etc.).

Typical data supplied for power sources would be as follows:

IDENTIFICATION	1	2	3
ITEM	DC Starter-Generator	Inverter	Battery
No of Units	2	1	1
Continuous Rating (Nameplate)	250A	300VA (Total)	35Ah
5 second Rating	400A		
2 minute Rating	300A		
Voltage	30V	115VAC	24VDC
Frequency	-	400Hz	-
Power Factor	-	0.8	-
Manufacturer	ABC	XYZ	ABC
Model No	123	456	789
Voltage Regulation	+/- 0.6V	+/-2%	-
Frequency Regulation	-	400Hz +/-1%	-

- iv) Operating logic of system (e.g. automatic switching, loading shedding etc.);
- v) List of installed equipment.

b) Assumptions and Criteria

All assumptions and design criteria used for the analysis should be stated in this section of the load analysis.

For example, typical assumptions for the analysis may be identified as follows:

- Most severe loading conditions and operational environment in which the aeroplane will be expected to operate are assumed to be night and in icing conditions.

- Momentary/intermittent loads, such as electrically operated valves, which open and close in a few seconds are not included in the calculations.
- Galley utilisation.
- Motor load demands are shown for steady-state operation and do not include starting inrush power. The overload ratings of the power sources should be shown to be adequate to provide motor starting inrush requirements.
- Intermittent loads such as communications equipment (radios e.g. VHF/HF comms.), which may have different current consumption depending on operating mode (i.e. transmit or receive).
- Cyclic loads such as heaters, pumps etc. (duty cycle).
- Estimation of load current, assuming a voltage drop between busbar and load.
- Power factors would need to be estimated for equipment, if unknown.

c) **AC and DC Load Analysis – Tabulation of Values**

A typical 'Load and Power Source Analysis' would identify the following details in tabular form:

Connected Load Table:

- i) **Aircraft Busbar, Circuit description and Circuit code**
- ii) **Load at Circuit Breaker.** Ampere loading for DC circuits and Watts/VA, VARs, power factor for AC circuits.
- iii) **Operating Time.** Usually expressed as a period of time (seconds/minutes) or may be continuous, as appropriate. Equipment operating time is often related to the average operating time of the aircraft. If the 'on' time of the equipment is the same or close to the average operating time of the aircraft, then it could be considered that the equipment is operating continuously for all flight phases.

In such cases, where suitable provision has been made to ensure that certain loads cannot operate simultaneously or where there is reason for assuming certain combinations of load will not occur, appropriate allowances may be made. Adequate explanation should be given in the summary.

In some instances, it may be useful to tabulate the data using a specified range for equipment operating times, such as follows:

- 5-second analysis - All loads that last longer than 0.3 seconds should be entered in this column.
- 5-minute analysis - All loads that last longer than 5 seconds should be entered in this column.
- Continuous analysis - All loads that last longer than five minutes should be entered in this column.

Alternatively, the equipment operating times could be expressed as follows:

- Actual operating time of equipment, in seconds or minutes; or
- Continuous operation.

In the examples given in Appendices 1 and 2, the approach taken is to show either continuous operation or to identify a specific operating time in seconds/minutes.

- iv) **Condition of aircraft operation.** Phase of pre-flight and flight (such as ground operation and loading, taxi, take-off, cruise, land).

For commercial aircraft, the following conditions could be considered:

- Ground Operation and Loading (30 mins – typically)
- Engine Start (5 mins – typically)
- Taxi (10 mins - typically)
- Take-off and Climb (30 mins – typically to optimum cruise height)
- Cruise (as appropriate for aircraft type)
- Landing (30 mins - typically)

The following conditions could be used for a typical helicopter operation:

- Engine Start and warm-up (night) (10 mins - typically)
- Take-off and climb (night) (10 mins - typically)
- Cruise (night) (30 mins - typically)
- Cruise (day) (30 mins - typically)
- Landing (night) (10 mins - typically)
- Emergency Landing (night) (5 mins - typically)¹
- One Generator Cruise (night) (10 mins - typically)²

1. Considers the failure of all generated power (i.e. Emergency Operation).

2. Considers the loss of a single generator (assuming two generators) (i.e. Abnormal Operation).

In some cases, the helicopter operations may be utilised in a specialised role (e.g. search and rescue, North sea operations etc.). The ELA should be reviewed and revised accordingly to take into account any significant changes to the conditions or operating times that were specified in the original ELA.

- v) **Condition of Power Sources.** Normal, Abnormal (Abnormal conditions to be specified e.g. one generator inoperative, two generators inoperative etc.) and Emergency.

The following Aircraft Operating Phases should be considered for the Electrical Load Analysis and would typically assume 'night' conditions as being the worst-case scenario.

In addition, icing conditions should also be considered for worst-case scenario. However, it should be noted that in some cases, the icing system is de-energised to operate and so icing may not always be the worst-case.

The analysis should also identify permissible unserviceabilities likely to be authorised in the Master Minimum Equipment List (MMEL) during the Certification of the aeroplane and should include calculations appropriate to these cases.

The following definitions are used when considering Normal, Abnormal and Emergency Electrical Power Operation:

Normal Electrical Power Operation. Normal operating conditions assumes that all of the available electrical power systems are functioning correctly within MMEL limitations (e.g. AC and/or DC Generators, Transformer Rectifier Units, Inverters, Main Batteries, Auxiliary Power Unit etc.).

Abnormal Electrical Power Operation (or Abnormal Operation). Abnormal operation occurs when a malfunction or failure in the electric system has taken place and the protective devices of the system are operating to remove the malfunction or the failure from the remainder of the system before the limits of abnormal operation are exceeded. The power source may operate in a degraded mode on a continuous basis where the power characteristics supplied to the utilisation equipment exceed normal operation limits but remain within the limits for abnormal operation (e.g. a single generator failure on an aircraft with two electrical generators).

Emergency Electrical Power Operation (or Emergency Operation). Emergency operation is a condition that occurs following a loss of all normal electrical generating power sources or other malfunction that results in operation on standby power (batteries and/or other emergency generating sources such as an APU or Ram Air Turbine) only. Also identified as 'operation without normal electrical power' – CS 25.1351(d) and AMC.

In some cases, the ELA will include a specific section covering Extended Range Operations requirements (Reference AMC-20) and will address 'total loss of normal generated electrical power' for the extended range conditions specified.

Typical phases of Normal Aircraft Operation are identified and defined as follows: Ground and Loading, Engine Start, Taxi, Take-off and Climb, Cruise and Land.

Ground Operation and Loading. Preparation of aircraft prior to aircraft engine start. During this period, power is supplied by APU, internal batteries or an external power source.

Taxi. Taxi is the condition from the aircraft's first movement under its own power to the start of the take-off run, and from completion of landing rollout to engine shutdown.

Take-off and Climb. Take-off and climb is that condition commencing with the take-off run and ending with the aircraft levelled-off and set for optimum cruising.

Cruise. Cruise is that condition during which the aircraft is in level flight.

Landing. Landing is that condition commencing with the operation of navigational and indication equipment specific to the landing approach and following to the completion of the rollout.

- vi) **Calculations.** The following calculations can be used to estimate total current, maximum demand and average demand for each of the aircraft operating phases (Ground Operation and Loading, Engine Start, Taxi, Take-off and Climb, Cruise and Landing):

Total Current (Amps) = Number of Units Operating Simultaneously x (multiplied by) Current per Unit (Amps);

or

Total Current (Amp-Min) = Number of Units Operating Simultaneously x (multiplied by) Current per Unit (Amps) x Operating time (Min)

Volt-amperes (VA or kVA) = Voltage x Current

Maximum Demand or Maximum Load (Amps) = Number of Units Operating Simultaneously x (multiplied by) Current per Unit (Amps);

or

Maximum Demand or Maximum Load (Volt-Amps, VA or kVA) = Number of Units Operating Simultaneously x Current per Unit (Amps) x (multiplied by) Supply Voltage (Volts)

It should be noted that the addition of AC load using kVA and Power Factor is a vector addition and is not an algebraic addition.

kW is the effective power

kVA is the apparent power

kVAR is the reactive power

NOTE: Volt-amperes (VA) = $(\text{watts}^2 + \text{vars}^2)^{1/2}$
 Power Factor (PF) = W/VA, W = watts
 Power = Voltage x Current x Power Factor (in watts)
 For sinusoidal supplies a convenient form is
 Power Factor = $\cos \Phi$
 Where Φ is the angle of lag or lead between V and I.
 $\cos \Phi = \text{kW/kVA}$ therefore $\text{kVA} = \text{kW}/\cos \Phi$
 $\text{kVAR} = \text{kVA} \sin \Phi$
 Total kVA = $\sqrt{(\text{kW}^2 + \text{kVAR}^2)}$
 Power Factor of total load = kW/kVA

Worked Example for addition of AC loads with varying Power Factors:

Cabin Lighting (capacitive) 20 kW at p.f of 0.92 leading

Flap Motor (inductive) 75 kW at p.f of 0.7 lagging

Heater (resistive) 45 kW at p.f of 1.0

Cabin Lighting $\text{kVA}_1 = 20/0.92 = 21.74 \text{ kVA}$

Flap Motor $\text{kVA}_2 = 75/0.7 = 107.2 \text{ kVA}$

Heater $\text{kVA}_3 = 45/1 = 45.0 \text{ kVA}$

$\cos \Phi_1 = 0.92$ therefore $\Phi_1 = 23^\circ 4'$

$\cos \Phi_2 = 0.7$ therefore $\Phi_2 = 45^\circ 34'$

$\text{kVAR}_1 = \text{kVA}_1 \sin \Phi_1 = 21.74 \times 0.3919 = 8.520 \text{ kVAR}$

$\text{kVAR}_2 = \text{kVA}_2 \sin \Phi_2 = 107.2 \times -0.7141 = -76.52 \text{ kVAR}$

Total kVAR = -68.00 kVAR

Total kW = $20 + 75 + 45 = 140 \text{ kW}$

Total kVA = $\sqrt{(\text{kW}^2 + \text{kVAR}^2)} = \sqrt{(140^2 + (-68.00)^2)} = 155.64 \text{ kVA}$

Power factor of total load = $\text{kW/kVA} = 140/155.64 = 0.899520$ lagging

Average Demand or Average Load (Amps) = Total Current (Amps-Minute) (divided by) Duration of Ground or Flight Phase (Minutes);

or

Average Demand or Average Load (Volt-Amps, VA or kVA) = Total Current (Amps-Minute) (divided by) Duration of Ground or Flight Phase (Minutes) x Supply Voltage (Volts)

It can be considered that at the start of each operating period (e.g. taxi, take-off, etc.), all equipment that operates during that phase is considered to be switched 'On', with intermittent loads gradually being switched 'Off'.

Intermittent Loads. For intermittent peak loads, root mean square (RMS) values of current should be calculated. Where the currents are continuous, the RMS and the average values will be the same, however, where several intermittent peak loads are spread over a period of time, the RMS value will be more accurate than the average.

Additional Considerations:

Non-Ohmic or constant power devices (e.g. Inverters). In some cases, the currents drawn at battery voltage (e.g. 20-24VDC) are higher than at the generated voltage (e.g. 28VDC) and will influence the emergency flight conditions on battery. However, for resistive loads, the current drawn will be reduced due to the lower battery voltage.

NOTE: Where the currents are continuous, the RMS and average values will be the same. However, where several intermittent peak loads are spread over a period, the RMS value will be more accurate than the average.

System Regulation

The system voltage and frequency should be regulated to ensure reliable and continued safe operation of all essential equipment while operating under the normal and emergency conditions, taking into account the voltage drops which occur in the cables and connections to the equipment.

The following definitions are provided in ED-14D (16.5.2.1) for maximum, nominal, minimum and emergency operations (28VDC System):

Maximum	30.3 volts
Nominal	27.5 volts
Minimum	22.0 volts
Emergency	18.0 volts

The defined voltages are those supplied at the equipment terminals and allows for variation in the output of the supply equipment (e.g. generators, batteries etc.) as well as voltage drops due to cable and connection resistance.

NOTE: Voltage drop between busbar and equipment should be considered in conjunction with busbar voltages under normal, abnormal and emergency operating conditions in the estimation of the terminal voltage at the equipment i.e. reduced busbar voltage in conjunction with cable volt drop could lead to malfunction or shutdown of equipment.

Load Shedding

Following the loss of a power source or sources it is considered that a 5 minute period will elapse prior to any manual load shedding by the flight crew, provided that the failure warning system has clear and unambiguous attention-getting

characteristics (refer to AMC 25.1351(d)). However, any automatic load shedding can be assumed to take place immediately.

NOTE: 10 minutes should be used where no flashing warning is provided to the flight crew.

Where automatic load shedding is provided, a description of the load(s) that will be shed should be provided with any specific sequencing, if applicable.

d) Emergency or Standby Power Operations

Where standby power is provided by non-time limited sources such as a Ram Air Turbine (RAT), Auxiliary Power Unit (APU), pneumatic or hydraulic motor, the emergency loads should be listed and evaluated such that the demand does not exceed emergency generator capacity.

Where batteries may be used to provide a time limited emergency supply for certain phases of flight e.g. landing, an analysis of battery capacity should be undertaken. This should be compared with the time necessary for the particular phase (e.g. from slat extension to landing including rollout) of flight where batteries may be utilised in lieu of non-time limited sources.

Battery Condition Calculations

Battery Duration. Battery endurance can be estimated from either a practical test, which involves applying typical aircraft loads for a period of time, or by calculation. It is important that considerations be given to the initial conditions of the aircraft (e.g. condition and state of charge of battery).

Using the material of AMC 25.1351 (d) (17 October 2003), the required duration of a time limited power source (e.g. battery), which is used as an alternative to the normal power sources, will depend on the type and role of the aircraft. Unless it can be shown that a lesser time is adequate, such a power source should have an endurance of at least 60 minutes, at least 30 minutes of which is available under IMC. The endurances of the time limited power source, with any associated procedures, should be specified in the Flight Manual.

Calculation

An accurate theoretical assessment of the battery performance requires a load analysis to be compiled and the discharge figures checked against the battery manufacturer's discharge curves and data sheets.

The capacity of a battery is:

Rate of discharge (amps) x Time to discharge

Normally expressed in ampere-hours, but for a typical load analysis, calculations are usually expressed in amp-mins (i.e. amp-hours x 60). However, this is not a linear function for with heavier discharge currents the discharge time decreases more rapidly so that the power available is less (i.e. reduced efficiency).

Therefore, in order to make an accurate assessment of battery duration, reference should be made to the manufacturer's discharge curves. However, it is recognised that these may not be available and certain assumptions and approximations are provided in the following paragraphs to allow for this case.

Because of the problem of definition of capacity it is first necessary to ensure that all calculations are based on the one-hour rate. Some manufacturers however do not give this on the nameplate and quote the five-hour rate. For these calculations, as a general rule, it may be assumed that the one-hour rate is 85% of the quoted five-hour rate.

Following the generator system failure and before the pilot has completed the load shedding drills the battery may be subjected to high discharge currents with a resultant loss of efficiency and capacity on the principle explained in the previous paragraph.

To make allowance for such losses, the calculated power consumed during the pre-load shed period should be factored by an additional 20% if the average discharge current in amps is numerically more than twice the one-hour rating of the battery.

It should be noted that the discharge rate of a lead-acid battery is different than that of a nickel cadmium battery. The following graph shows a typical discharge curve for lead-acid and nickel-cadmium battery at a 5 amp discharge rate.

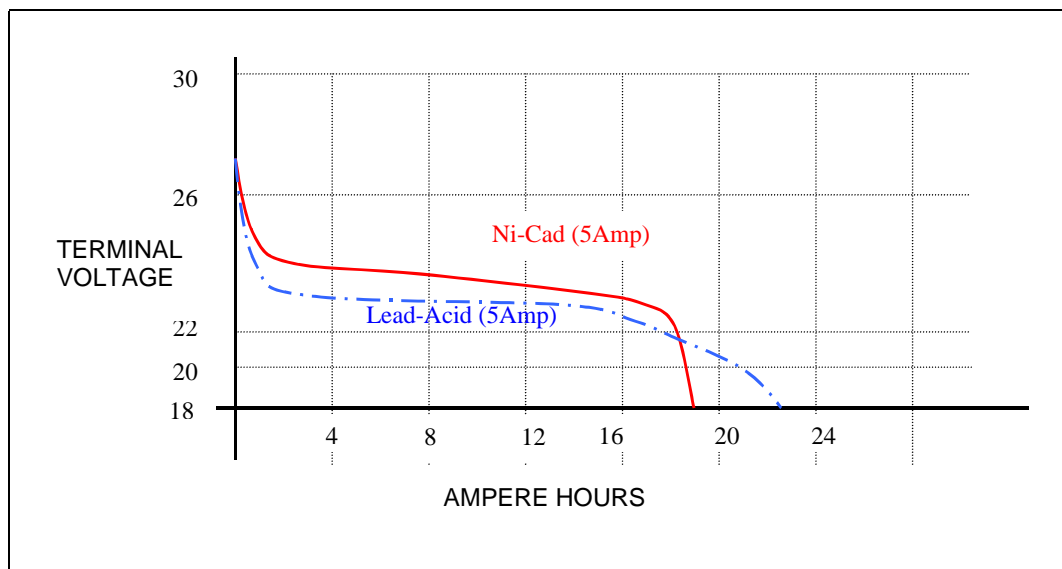

Figure 1 Typical discharge rates of lead-acid and nickel-cadmium batteries

AMC 25.1351(d)(6.1)(b) (17 October 2003) states:

“Unless otherwise agreed, for the purpose of this calculation, a battery capacity at normal ambient conditions of 80% of the nameplate rated capacity, at the one-hour rate, and a 90% state of charge, may be assumed (i.e. 72% of nominal demonstrated rated capacity at +20°C). The allowance for battery endurance presumes that adequate requirements for periodic battery maintenance have been agreed.”

Battery-Charging Current Analysis

The charging current for any aircraft battery is based on the total elapsed time from the beginning of the charge, and is calculated using the following formula:

I = A x C where,

- I** is the average charging current in Amperes.
- A** is the Ampere-hour capacity of the battery, based on the one-hour discharge rate.
- C** is the battery-charging factor taken from the battery-charging curve supplied with battery data (graphical data).

An example of how to calculate the battery duration is given below:

- i) Check the nameplate capacity of the battery and assume 72% is available
e.g. 12 amp-hour = 720 amp-mins.

Therefore, 72% is equal to 518.4 amp-mins.

- ii) Estimate the normal or pre-load shed cruise consumption (assume worst-case cruise at night). For example, 15 amps (15 amps x 5 mins = 75 amp-mins).

This assumes 5 minutes for pilot to shed non-essential loads following a low voltage warning. Any automatic load shedding can be assumed to be immediate and need not be considered in the pre-load shed calculations.

- iii) Estimate the minimum cruise load necessary to maintain flight after the generator/alternator has failed e.g. 10 amps.

- iv) Estimate the consumption required during the landing approach e.g. 20 amps for 5 minutes (100 amp-mins).

The cruise duration is therefore:

$$\frac{\text{Battery Capacity (i)} - [\text{Pre-Load Shed (ii)} + \text{Landing Load (iv)}]}{\text{Cruise Load (iii)}} = \frac{\text{(i)} - [\text{(ii)} + \text{(iv)}]}{\text{(iii)}}$$

$$= \frac{518.4 - (75 + 100)}{10} = \frac{343.4}{10} = 34 \text{ mins}$$

Total Duration = Pre-Load Shed Cruise Time + Cruise Duration + Landing Time

Total Duration = 5 + 34 + 5 = 44 minutes.

e) Summary and Conclusions**Summary**

The Electrical Load Analysis summary should provide evidence that for each operating condition, the available power can meet the loading requirements with adequate margin for both peak loads and maximum continuous loads. This should take into account both the normal and abnormal (including emergency) operating conditions.

For AC systems, these summaries should include power factor and phase loadings.

Conclusions

The conclusions should include statements that confirm that the various power sources can satisfactorily supply electrical power to necessary equipment during normal and abnormal operation under the most severe operating conditions as identified in the analysis. It should be confirmed that the limits of the power supplies are not exceeded.

6 Example of AC and DC Electrical Load Analysis

- 6.1 As stated previously, the Electrical Load Analysis is designed to show capability of the electrical system under various ground and flight operating conditions. The analysis should verify that the electrical power sources would provide power to each circuit essential for the safe operation of the aircraft.

6.2 The examples provided are intentionally over-simplified to clarify the process involved. The applicable design organisation is responsible for the selection of the method of analysis.

6.3 A typical electrical load utilisation and analysis for an AC and DC aircraft is provided in Appendices 1 (DC analysis) and 2 (AC analysis) of this document.

In addition, Appendix 3 provides an analysis (DC and AC) derived from BCAR Section J (historical data), which provides a more detailed analysis.

7 Practical Test (Ground or Air)

Practical testing may be used as an expedient method of verifying certain loads and would be used as supporting data in the compilation of the Electrical Load Analysis.

8 Definitions

The following definitions are applicable to this Leaflet:

An **Electrical System** consists of an electrical power source, its power distribution system and the electrical load connected to that system.

An **Electrical Source** is the electrical equipment which produces, converts, or transforms electrical power. Some common AC sources are identified as follows: AC Generators, inverters, transformers and frequency changers. Some common DC sources are DC Generators, converters and batteries. In practice an electrical source could be a combination of these units connected in parallel e.g. a typical AC bus may have both AC Generators and inverters connected in parallel.

A **Primary** source is equipment that generates electrical power from energy other than electrical, and is independent of any other electrical source. For example, the Primary source of an AC electric system may be the main engine-driven generator(s) or Auxiliary Power Unit-driven generator(s). The Primary source of a DC electrical system may be a battery, main engine-driven generator(s) or Auxiliary Power Unit-driven generator(s). There may be both AC and DC Primary power sources in the same aircraft.

A **Secondary** source is equipment that transforms and/or converts Primary source power to supply electrical power to either AC or DC powered equipment. A Secondary source is entirely dependent upon the Primary source and is considered part of the load of the Primary source. There may be both an AC and DC Secondary source in the same aircraft.

The **Normal** source is that source which provides electrical power throughout the routine aircraft operation.

An **Alternate** source is a second power source, which may be used in lieu of the Normal source, usually upon failure of the Normal source. The use of alternate sources creates a new load and power configuration, and therefore a new electrical system, which may require separate source capacity analysis.

The **Nominal Rating** of a unit power source is its nameplate rating. This rating is usually a continuous duty rating for specified operating conditions.

The **Growth Capacity** is a measure of the power source capacity available to the aircraft electrical system to supply future load equipment. This value is expressed in terms of percent of source capacity.

Grounding Operation and Loading. Preparation of aircraft prior to aircraft engine start. During this period power is supplied by APU, internal batteries or an external power source.

Taxi. Taxi is the condition from the aircraft's first movement under its own power to the start of the take-off run and from completion of landing rollout to engine shutdown.

Take-off and Climb. Take-off and climb is that condition commencing with the take-off run and ending with the aircraft levelled-off and set for cruising.

Cruise. Cruise is that condition during which the aircraft is in level flight.

Landing. Landing is that condition commencing with the operation of navigational and indication equipment specific to the landing approach and following to the completion of the rollout.

Normal Electrical Power Operation (or Normal Operation). Normal Operating conditions assumes that all of the available electrical power system is functioning correctly within MMEL limitations (e.g. AC and/or DC Generators, Transformer Rectifier Units, Inverters, Main Batteries, Auxiliary Power Unit etc.).

Abnormal Electrical Power Operation (or Abnormal Operation). Abnormal operation occurs when a malfunction or failure in the electric system has taken place and the protective devices of the system are operating to remove the malfunction or the failure from the remainder of the system before the limits of abnormal operation are exceeded. The power source may operate in a degraded mode on a continuous basis where the power characteristics supplied to the utilisation equipment exceed normal operation limits but remain within the limits for abnormal operation.

Emergency Electrical Power Operation (or Emergency Operation). Emergency operation is a condition that occurs following a loss of all normal electrical generating power sources or other malfunction that results in operation on standby power (batteries and/or other emergency generating sources such as an APU or Ram Air Turbine) only. Also identified as 'operation without normal electrical power' – CS 25.1351(d) and AMC.

Power Factor. The ratio of real power (measured in watts) to apparent power (measured in volt-amperes).

APPENDIX 1

Typical DC Electrical Load Analysis (Normal and Emergency)

Table 1 Electrical Load Analysis (DC – Current) – Normal Operating Conditions

CIRCUIT/SERVICE	CB	BUS – DC1			NORMAL CONDITIONS							
		LOAD AT CCT BREAKER	OP TIME	APPROPRIATE CONDITIONS	NOTES	TAXIING (NIGHT) 30 MINS		TAKE OFF & LAND (NIGHT) 10 MINS		CRUISE (NIGHT) 60 MINS		
		AMPS	MINS			AMPS	AMP-MINS	AMPS	AMP-MINS	AMPS	AMP-MINS	
AIR CONDITIONING												
DUMP DITCH MOTORS	AB1	0.90	0.1	A,B,C	a,b,c	-	-	-	-	-	-	
CABIN ALT WARNING	AB2	0.04	CONT	A,B,C	a,b,c	0.04	1.2	0.04	0.4	0.04	2.4	
MAN. PRESSURE CONTROL	AB3	0.60	CONT	A,B,C	a,b	-	-	-	-	-	-	
COMMUNICATIONS												
ACARS MEMORY	BC1	0.08	CONT	A,B,C	a,c	0.08	2.4	0.08	0.8	0.08	4.8	
ELECTRICAL POWER												
BATTERY 1 CHARGE	CD1	3.50	CONT	A,B,C	a,b	3.50	105.0	3.50	35.0	3.50	210.0	
**	**	**	**	**	a,c	**	**	**	**	**	**	
**	**	**	**	**	a,b,c	**	**	**	**	**	**	
**	**	**	**	**	a,b,c	**	**	**	**	**	**	
**	**	**	**	**	a,b,c	**	**	**	**	**	**	
BATTERY 1 TEMP PROT	CD2	0.04	CONT	A,B,C	a,b	0.04	1.2	0.04	0.4	0.04	2.4	
		TOTALS				200		100		300		
				MAXIMUM DEMAND (AMPS)		15		24		12		
				AVERAGE DEMAND (AMPS)		6.7		10		5		

Table 2 Electrical Load Analysis (DC – Current) – Emergency Operating Conditions

CIRCUIT/SERVICE	BUS – DC1				EMERGENCY (Failure of one power-unit or generator)							
	CB	LOAD AT CCT BREAKER	OP TIME	APPROPRIATE CONDITIONS	NOTES	CRUISE (NIGHT) PRIOR TO LOAD SHED 5 MINS		CRUISE (NIGHT) AFTER LOAD SHEDDING 60 MINS		LAND (NIGHT) 10 MINS		
						AMPS	AMP-MINS	AMPS	AMP-MINS	AMPS	AMP-MINS	
AIR CONDITIONING												
DUMP DITCH MOTORS	AB1	0.90	0.1	A,B,C	a,b,c	-	-	-	-	-	-	-
CABIN ALT WARNING	AB2	0.04	CONT	A,B,C	a,b,c	0.04	0.2	0.04	2.4	0.04	0.4	0.4
MAN. PRESSURE CONTROL	AB3	0.60	CONT	A,B,C	a,b	-	-	-	-	-	-	-
COMMUNICATIONS												
ACARS MEMORY	BC1	0.08	CONT	A,B,C	a,c	0.08	0.4	0.08	4.8	0.08	0.08	0.8
ELECTRICAL POWER												
BATTERY 1 CHARGE	CD1	3.50	CONT	A,B,C	a,b	3.50	175.0	3.50	210	3.50	3.50	35.0
**	**	**	**	**	a,c	**	**	**	**	**	**	**
**	**	**	**	**	a,b,c	**	**	**	**	**	**	**
**	**	**	**	**	a,b,c	**	**	**	**	**	**	**
**	**	**	**	**	a,b,c	**	**	**	**	**	**	**
BATTERY 1 TEMP PROT	CD2	0.04	CONT	A,B,C	a,b	0.04	0.2	0.04	2.4	0.04	0.04	0.4
TOTALS		TOTAL (AMP-MINS)				50		300		12		100
		MAXIMUM DEMAND (AMPS)		15		24						
		AVERAGE DEMAND (AMPS)		10		5						10

APPENDIX 2

Table 3 Electrical Load Analysis (AC – Current) – Normal Operating Conditions

CIRCUIT/SERVICE	CB	BUS – AC1				NORMAL CONDITIONS								
		LOAD AT CCT BREAKER		OP TIME	APPROPRIATE CONDITIONS	NOTES	TAXIING (NIGHT) 30 MINS		TAKE OFF & LAND (NIGHT) 10 MINS		CRUISE (NIGHT) 60 MINS			
		WATTS	VARS	MINS	WATTS		VARS	WATTS	VARS	WATTS	VARS			
AIR CONDITIONING														
AUTO TEMP FLT DECK	AB1	33.0	17.0	CONT	A,B,C	a,b, c	33.0	17.0	33.0	17.0	33.0	17.0	33.0	17.0
AUTO PRESS CONT	AB2	30.0		CONT	A,B,C	a,b,c	30.0		30.0		30.0		30.0	
MAN. TEMP CTL	AB3	11.0	7.0	CONT	A,B,C	a,b	11.0	7.0	11.0	7.0	11.0	7.0	11.0	7.0
COMMUNICATIONS														
ACARS PRINTER	BC1	60.0		CONT	A,B,C	a,c	60.0		60.0		60.0		60.0	
ELECTRICAL POWER														
AC1 BUS FAIL	CD1	4.0		CONT	A,B,C	a,b	4.0		4.0		4.0		4.0	
**	**			**	**	a,c	**	**	**	**	**	**	**	**
**	**			**	**	a,b,c	**	**	**	**	**	**	**	**
**	**			**	**	a,b,c	**	**	**	**	**	**	**	**
**	**			**	**	a,b,c	**	**	**	**	**	**	**	**
ESS BUS FAIL	CD2	8.0		CONT	A,B,C	a,b	8.0		8.0		8.0		8.0	
		TOTALS		BUS TOTAL KW / KVAR			400	50	400	50	400	50	400	50

Table 4 Electrical Load Analysis (AC – Current) – Abnormal Operating Conditions (Failure Of One Generator)

CIRCUIT/SERVICE	CB	BUS – AC1				EMERGENCY (Failure of one power-unit or generator)					
		LOAD AT CCT BREAKER		OP TIME	APPROPRIATE CONDITIONS	NOTES	CRUISE (NIGHT)		LAND (NIGHT)		
		WATTS	VARs	MINS			WATTS	VARs	WATTS	VARs	
AIR CONDITIONING											
AUTO TEMP FLT DECK	AB1	33.0	17.0	CONT	A,B,C	a,b, c		33.0	17.0	33.0	17.0
AUTO PRESS CONT	AB2	30.0		CONT	A,B,C	a,b,c		30.0		30.0	
MAN. TEMP CTL	AB3	11.0	7.0	CONT	A,B,C	a,b		11.0	7.0	11.0	7.0
COMMUNICATIONS											
ACARS PRINTER	BC1	60.0		CONT	A,B,C	a,c		60.0		60.0	
ELECTRICAL POWER											
AC1 BUS FAIL	CD1	4.0		CONT	A,B,C	a,b		4.0		4.0	
**	**			**	**	a,c		**	**	**	**
**	**			**	**	a,b,c		**	**	**	**
**	**			**	**	a,b,c		**	**	**	**
**	**			**	**	a,b,c		**	**	**	**
ESS BUS FAIL	CD2	8.0		CONT	A,B,C	a,b		8.0		8.0	
		TOTALS		BUS TOTAL KW / KVAR				400	50	400	50

APPENDIX 3

Table 5 DC System : 28 V

1 Item	2 Service	Aircraft – Two Power Units Flight Duration : 3 Hours Electrical System : Earth Return DC 28 V; 2 Generators 3kW at Cruise, 1.5 kW at taxiing; 1 battery 37 Ah (Ten-Hour Rate)							Conditions of Aircraft operation																
		3 Units per A/C	4 Units op simult	5 Current at 95% volts (amp)	6 Drop in line volts (volt)	7 Op Time (min or sec)	8 No of times ON	9 Taxi (night) 30 mins	10 Take-off and land (night) 10 mins		11 Cruise (day) 60 mins		12 Cruise (night) 60 mins		13 Cruise (night) prior to load shed 5 mins		14 Cruise (night) after load shed 60 mins		15 Land (night) 10 mins						
								amp	amp-min	amp	amp-min	amp	amp-min	amp	amp-min	amp	amp-min	amp	amp-min	amp	amp-min				
1	Motor, Flaps	1	1	120	6	15s	1	120	30	120	30	-	-	-	-	-	-	-	-	-	-	120	30		
2	Prop, feather	2	1	100	5	15s	1	-	-	100	25	-	-	-	-	-	-	-	-	-	-	-	-	-	
3	Motor, U/C	1	1	160	8	30s	1	-	-	160	80	-	-	-	-	-	-	-	-	-	-	160	80		
4	Trim tab motor	3	1	4	1	1	3	4	12	4	36	4	36	4	12	4	36	4	36	4	36	4	12		
5	Cowl flaps	2	2	10	2	3	2	20	60	20	60	20	60	20	60	20	60	20	60	20	60	20	60		
6	Water heater	1	1	25	2	10	2	-	-	-	-	-	-	-	-	-	-	-	-	-	-	-	-		
7	Galley	1	1	40	2	15	1	-	-	-	-	-	-	-	-	-	-	-	-	-	-	-	-		
8	Radio Trans.	1	1	20	2	15	1	20	300	20	200	20	300	20	300	20	300	20	300	20	300	20	200		
9	Fuel Trans. pump	2	1	10	2	15	1	-	-	-	-	-	-	-	-	-	-	-	-	-	-	-	-		
10	Motor de-icing	1	1	5	1	15	1	-	-	5	50	5	75	5	75	5	25	5	75	5	75	5	50		
11	Prop. Auto Ctl	2	2	5	1.5	Cont	Cont	10	300	10	100	10	600	10	600	10	50	10	600	10	600	10	100		
12	Fuel Boost pump	2	2	10	2	Cont	Cont	-	-	20	200	20	1200	20	1200	20	100	20	1200	20	1200	20	200		
13	Engine Inst.	12	12	1	0.5	Cont	Cont	12	360	12	120	12	720	12	720	12	60	12	720	12	720	12	120		
14(a)	Int. light (Ess)	5	5	1	0.5	Cont	Cont	5	150	5	50	-	-	5	300	5	25	5	300	5	300	5	50		
14(b)	Int. Lights (non-essential)	10	10	1	0.5	Cont	Cont	10	300	10	100	-	-	-	10	600	10	50	-	-	-	-	-		
15	Nav. Lights	5	5	1	0.5	Cont	Cont	5	150	5	50	-	-	-	5	300	5	25	5	300	5	300	5	50	
16	Vent Fans	6	6	5	1.5	Cont	Cont	30	900	5	50	5	300	5	300	5	25	5	300	5	300	5	-		
17	Refrigerator	1	1	15	2	Cont	Cont	15	450	15	150	15	900	15	900	15	75	15	900	15	900	15	-		
18	Autopilot Inv.	1	1	5	1	Cont	Cont	-	-	-	-	-	-	-	-	-	-	-	-	-	-	-	-		
19	Inst. (flight) inv.	1	1	5	1	Cont	Cont	5	150	5	50	5	300	5	300	5	25	5	300	5	300	5	50		
20	Radio Receiver	1	1	5	1	Cont	Cont	5	150	5	50	5	300	5	300	5	25	5	300	5	300	5	50		
21	Intercomm.	1	1	5	1	Cont	Cont	5	150	5	50	5	300	5	300	5	25	5	300	5	300	5	50		
								Total (amp-min)		1427		6641		7841		1057		4641				1102			
								Maximum Demand (amp)		266		526		226		126		316		77				396	
								Average Demand (amp)		115		143		131		77		211						110	

Table 5 considers a two-engined aircraft of medium range with a DC generator driven by each engine. The headings of each column are self-explanatory in general, but where explanation is considered necessary it is given below.

Column 5 – For column 5, it is necessary to choose an arbitrary value of voltage for the estimation of current consumption. For this case a value of 95% E_{max} has been used.

Column 6 – Column 6 gives the drop in line voltage between the busbar and the equipment, assuming the current consumption shown in column 5. This voltage drop should be considered in conjunction with busbar voltages under normal and emergency conditions in the estimation of the terminal voltage at the equipment.

Column 10 – Column 10 gives the loading conditions immediately following a power-unit failure during take-off. This condition is assumed to persist for 10 minutes. This could be considered as an abnormal operating condition.

Table 6 Battery Capacity Analysis

1	2	3	4	5	6	7
Item No	Equipment	Units	Total Demand per unit (amp)	Time (mins or secs)	Amp-min in 20 min period	Simultaneous demand (amp)
1	Motor, Flaps	1	120	0-15 secs	30	120
2	Prop, feather	2	100	0-15 secs	50	100
3	Motor, U/C	1	160	0-30 secs	80	160
4	Trim tab motor	3	4	1	12	4
5	Cowl flaps	2	10	3	60	20
8	Radio Trans.	1	15	15	225	15
9	Fuel Trans. pump	2	-	-	-	-
10	Motor de-icing	-	-	-	-	-
11	Prop. Auto Ctl	2	-	-	-	-
12	Fuel Boost pump	2	-	-	-	-
13	Engine Inst.	12	-	-	-	-
15	Nav. Lights	5	1	Cont	100	5
19	Inst. (flight) inv.	1	5	Cont	100	5
20	Radio Receiver	1	5	Cont	100	5
21	Intercomm.	1	5	Cont	100	5
	Totals				857	439

This table refers to the loading in the case of a forced descent and landing, with all power-units inoperative and the battery supplying power for the electrical loads essential during this period, which is assumed to be 20 minutes.

Column 7 gives the maximum demand which the battery must be capable of meeting while maintaining an adequate voltage at any time within the 20 minutes.

The summation of Column 6 gives a total consumption of 857 amp-min (i.e. 14 amp-hour).

Table 7 Electrical System : 200 volt 3-phase, 400 Hz (Nominal)

Item No	Service	No of Units	Units Op Simult.	Volt-amp per Unit		Op. Time (min)	Load Dist.		Normal Operation									
				Peak	Normal		Normal supply	Standby Supplies	Engine Start	11	12	13	14	15	16	17	18	19
1	2	3	4	5	6	7	8	9	10	11	12	13	14	15	16	17	18	19
								1st	2nd	A	P	S	A	P	S	A	P	S
1	Starter Motors	2	1	7000	600	0-10sec	A	-	-	7000	-	-	-	-	-	-	-	-
2	Propeller-Feathering (P)	1	1	2300	200	0-15sec	A	S	-	-	-	-	-	-	-	-	-	-
3	Propeller-Feathering (S)	1	1	2300	2000	0-15sec	A	P	-	-	-	-	-	-	-	-	-	-
4	Cowl Gill Motor (P)	1	1	150	150	0-20sec	P	A	S	-	150	-	-	-	-	-	-	-
5	Cowl Gill Motor (S)	1	1	150	150	0-20sec	S	A	P	-	-	150	-	-	-	-	-	-
6	Main Undercarriage (P)	1	1	4000	4000	0-10sec	P	A	-	-	-	-	-	4000	-	-	-	-
7	Main Undercarriage (S)	1	1	4000	4000	0-10sec	S	A	-	-	-	-	-	4000	-	-	-	-
8	Tail Wheel	1	1	500	500	0-10sec	S	A	-	-	-	-	-	500	-	-	-	-
9	Wing Flaps	1	1	500	500	0-20sec	P	A	-	-	500	-	-	500	-	-	-	-
10	Landing Lamps	2	2	200	200	10	P	A	S	-	400	-	-	400	-	-	-	-
11	Interior Lights A	Total	Total	100	100	C	P	A	S	100	100	-	-	100	-	-	100	-
12	Interior Lights B	Total	Total	300	300	C	S	A	P	-	-	300	-	-	300	-	-	300
13	Heating Load A	Total	Total	1000	1000	C	P	A	-	-	1000	-	-	1000	-	-	1000	-
14	Heating Load B	Total	Total	1000	1000	C	S	A	-	-	-	1000	-	-	1000	-	-	1000
15	Frequency Changer	1	1	2000	2000	C	S	A	P	-	-	2000	-	-	2000	-	-	2000
16	Frequency Compensator	1	1	2400	2400	C	P	A	S	1800	2400	-	-	2400	-	-	2400	-
17	Pressure Head Heater	1	1	100	100	C	S	A	P	-	-	-	-	-	-	-	-	100
18	Engine Controls (P)	Set	Set	200	200	C	P	A	S	200	200	-	-	200	-	-	200	-
19	Engine Controls (S)	Set	Set	200	200	C	S	A	P	200	-	200	-	-	200	-	-	200
20	Fuel Boost Pump (P)	1	1	150	150	C	P	A	S	150	150	-	-	150	-	-	150	-
21	Fuel Boost Pump (S)	1	1	150	150	C	S	A	P	150	-	150	-	-	150	-	-	150
22	Fuel Valves (P)	3	1	50	50	0-10sec	P	A	S	-	50	-	-	50	-	-	50	-
23	Fuel Valves (S)	3	1	50	50	0-10sec	S	A	P	-	-	50	-	-	50	-	-	50
24	Flying Control Servo	3	3	200	200	C & Int	P	A	S	-	600	-	-	600	-	-	600	-
25	Motor de-ice	1	1	150	150	C	S	A	P	-	-	-	-	-	-	-	-	150
26	Refrigerator	1	1	250	250	C	S	A	P	-	-	250	-	-	250	-	-	250
27	Navigation Lights	3	3	25	25	C	P	A	S	-	75	-	-	75	-	-	75	-
28	Windscreen Wiper	1	1	60	60	C	S	A	P	60	-	60	-	-	60	-	-	60
29																		
30																		
		Totals		10 seconds Peak Maximum Load (VA)						9660	5625	4160	0	8475	7510	0	4575	4260
		Totals		30 seconds Peak Maximum Load (VA)						2660	5575	4110	0	5425	3960	0	4525	4210
		Totals		Continuous Maximum Load (VA)						2660	4425	3960	0	4425	3960	0	4025	4210

Table 8 Electrical System : 200 volt 3-phase , 400 Hz (Nominal)

Item No	Service	No of Units	Units Op Simult.	Volt-amp per Unit		Op. Time (min)	Load Distribution		Abnormal Operation				Auxiliary Power Unit (APU)			Emergency Operation				
				Peak	Normal		Normal supply	Standby Supplies	Port power-unit and alternator off	Cruise (night)	Starboard power-unit and alternator off	Cruise (night)	Taxi (night)	Take-off or land (night)	Forced descent (night) and land					
1	2	3	4	5	6	7	8	9	10	11	12	13	14	15	16	17	18	19	20	21
1	Starter Motors	2	1	7000	600	0-10sec	A	1st	2nd	S	A	S	P	A	P	P	S	P	S	A
2	Propeller-Feathering (P)	1	1	2300	200	0-15sec	A	-	-	-	-	-	-	-	-	-	-	-	-	-
3	Propeller-Feathering (S)	1	1	2300	2000	0-15sec	A	S	-	-	2300	-	-	-	-	-	-	-	-	-
4	Cowl Gill Motor (P)	1	1	150	150	0-20sec	P	A	S	-	-	-	-	2300	2300	-	-	-	-	-
5	Cowl Gill Motor (S)	1	1	150	150	0-20sec	S	A	P	-	-	-	-	-	-	150	-	-	-	-
6	Main Undercarriage (P)	1	1	4000	4000	0-10sec	P	A	-	4000	4000	-	4000	-	-	-	-	4000	-	-
7	Main Undercarriage (S)	1	1	4000	4000	0-10sec	S	A	-	4000	-	-	4000	-	-	-	-	-	4000	-
8	Tail Wheel	1	1	500	500	0-10sec	S	A	-	500	-	-	500	-	-	-	-	-	500	-
9	Wing Flaps	1	1	500	500	0-20sec	P	A	-	-	500	-	500	-	-	500	-	-	500	-
10	Landing Lamps	2	2	200	200	10	P	A	S	-	400	-	400	-	-	400	-	-	400	-
11	Interior Lights A	Total	Total	100	100	C	P	A	S	-	100	-	100	-	-	100	-	-	100	-
12	Interior Lights B	Total	Total	300	300	C	S	A	P	300	-	300	-	300	-	300	-	-	300	-
13	Heating Load A	Total	Total	1000	1000	C	P	A	-	-	1000	-	1000	-	-	1000	-	-	1000	-
14	Heating Load B	Total	Total	1000	1000	C	S	A	-	1000	-	1000	-	1000	-	-	-	-	1000	-
15	Frequency Changer	1	1	2000	2000	C	S	A	P	2000	-	2000	-	2000	-	2000	-	-	2000	-
16	Frequency Compensator	1	1	2400	2400	C	P	A	S	-	1800	-	2400	-	2400	-	2400	-	2400	-
17	Pressure Head Heater	1	1	100	100	C	S	A	P	-	-	-	100	-	-	-	-	-	100	-
18	Engine Controls (P)	Set	Set	200	200	C	P	A	S	-	-	-	200	-	-	200	-	-	200	-
19	Engine Controls (S)	Set	Set	200	200	C	S	A	P	200	-	200	-	-	-	-	200	-	200	-
20	Fuel Boost Pump (P)	1	1	150	150	C	P	A	S	-	-	-	150	-	-	150	-	-	150	-
21	Fuel Boost Pump (S)	1	1	150	150	C	S	A	P	150	-	150	-	-	-	-	150	-	150	-
22	Fuel Valves (P)	3	1	50	50	0-10sec	P	A	S	-	50	-	50	-	50	-	50	-	50	-
23	Fuel Valves (S)	3	1	50	50	0-10sec	S	A	P	50	-	50	-	50	-	50	-	50	-	-
24	Flying Control Servo	3	3	200	200	C & Int	P	A	S	-	600	-	600	-	600	-	600	-	600	-
25	Motor device	1	1	150	150	C	S	A	P	-	-	-	150	-	-	-	-	-	150	-
26	Refrigerator	1	1	250	250	C	S	A	P	250	-	250	-	250	-	250	-	-	250	-
27	Navigation Lights	3	3	25	25	C	P	A	S	-	75	-	75	-	75	-	75	-	75	-
28	Windscreen Wiper	1	1	60	60	C	S	A	P	60	-	60	-	60	-	60	-	-	60	-
29																				
				Totals						7510	9825	9785	8475	9460	9785	5625	4160	8475	7510	6585
										3960	6775	9685	5425	5910	9685	5575	4110	5425	3960	6485
										3960	3475	6885	4425	3610	6885	4425	3960	4425	3960	5485

Tables 7 and 8 consider an aircraft with two power-units carrying one alternator per power-unit and an Auxiliary Power Unit (APU), the latter being primarily for use at low altitudes. The determination of the alternator capacity needed to supply the most onerous probable combination of loads is illustrated for the following conditions, Normal, Abnormal and Emergency (forced descent and land – night).

Leaflet 24-50 Electrical Generation Systems – Bus-Bar Low Voltage Warning Single-Engined Aircraft With A UK Certificate of Airworthiness

1 Introduction

This Leaflet provides guidance material to achieve compliance with CAP 747 GR No. 6, and provides a list of acceptable low voltage units currently available.

It was originally written to give guidance for compliance with CAA Airworthiness Notice (AN) No. 88. This AN has been notified to European Aviation Safety Agency (EASA) under Article 14.1 of Regulation (EC) 216/2008, and therefore the content is still appropriate. AN No. 88 has been transferred to CAP 747, Mandatory Requirements for Airworthiness, Appendix 1, Generic Requirement (GR) No. 6. These GRs are pending EASA review and concurrence. The resulting EASA Policy will supersede the validity of this Leaflet.

NOTE: CAA ANs that are notified to EASA have been transferred to CAP 747, Mandatory Requirements for Airworthiness, Appendix 1 as Generic Requirements. CAP 747 provides a single point of reference for all mandatory information for continuing airworthiness, including Airworthiness Directives, as applicable to civil aircraft registered in the UK.

The technical content and the paragraph numbering of GR No. 6 is identical to that of AN No. 88 Issue 3 dated 29 October 2001. Therefore, the guidance given in this Leaflet is also valid for GR No. 6. This Leaflet has been updated to reflect the changes in requirement references.

2 References

CAP 747 Mandatory Requirements for Airworthiness, Appendix 1, Generic Requirements, GR No. 6 dated 31 July 2008.

3 Low Voltage Units

- 3.1 GR No. 6 requires a single-engined aircraft equipped with an engine driven electrical generating system to be provided with a clear and unmistakable warning to the pilot that the alternator or DC generator output voltage has fallen to a level where the battery is supplying power to the electrical loads. However, the requirement is waived where an aircraft is equipped only to operate under day VMC conditions and where the loss of generated power could not prejudice continued safe flight and landing.
- 3.2 Service experience has shown that the following alternator/generator failure warnings will NOT be acceptable for compliance with GR No. 6:
 - a) Warnings sensed within the generator/alternator windings because they will not detect failures between the output terminals and distribution bus. This method of failure detection is known to be used on many models of Piper single-engined aircraft, and

- b) Warnings which rely upon wide voltage differentials because they will only operate when the output voltage is well below that of the battery, thus when the warning illuminates the battery may have lost a significant proportion of its capacity.

NOTE: Aircraft currently equipped with such systems should be modified to comply with GR No. 6.

4 Equipment

- 4.1 An acceptable means of compliance would be to provide a red bus bar low volts warning, similar to the 12 volt or 24 volt units, which were designed and manufactured for installation in multi-engined aircraft, for compliance with the requirements of CAP 747 GR No. 4. The following units have been found acceptable for satisfying the requirements of GR No. 6.

NOTE: The original CAA frozen E Number Type Approval is quoted below each device.

Avionics Mobile units: AM-LV14-00/AM-LV28-00
E13746

LRE units: E13823 L403-450-12/L403-450-24

Rogers Aviation units: RLV/14/28
E13887

CSE units: E13889 BVM14 and BVM28

Bradford units – from 3025-12/3025-14 (flashing)
McAlpines: E13845 3026-12/3026-24 (flashing, light dims when cancelled)
3027-12/3027-24 (steady, non dimming, non cancellable)

Advice may be sought from the Avionic and Electrical Systems Section of the CAA Safety Regulation Group, Aviation House, Gatwick, on the suitability of other devices which may be available. (See paragraph 10).

- 4.2 It is recognised that other manufacturers or individuals may wish to produce similar devices and for this reason the following specification is issued as general guidance on a standard which would be acceptable to the CAA in the first instance:

Specification

Indication: Red warning light – steady or flashing.

Flash Rate: 50 to 100 cycles per minute.
(Optional)

Dimming: Not acceptable unless automatic reset is provided.

Trigger Voltage: The warning lamp should illuminate decreasing voltage at:

- (i) 25.0 to 25.5 volts for 24 volt DC systems.
- (ii) 12.5 to 13.0 volts for 12 volt DC systems.

Resetting: The warning should reset automatically to extinguish the lamp on a rising voltage 0.5 volts above these settings.

Voltage Ranges:	33.0 to 18 volts DC or 16.5 to 9 volts DC.
Environmental Conditions:	Generally, in accordance with British Standards BS3G100 or EUROCAE ED-14 (RTCA DO-160), for example as follows:
Operating Temperature Range:	–10°C to 40°C
Mechanical Loads:	Units should be capable of withstanding typical shock and vibration loads found in service.
Moisture:	The unit should either be encapsulated or shown to be capable of withstanding ingress of moisture. A simple water spray test would be sufficient to show compliance.
Fire and Smoke Hazard:	Unit should not be capable of producing toxic fumes or smoke under fault conditions, neither should it be capable of supporting combustion.
Radio Interference:	The unit should not create interference on radio communication or navigation equipment.
Compass Interference:	The safe compass distance should be specified.
Identification:	The unit should carry an identification of the manufacturer, its part number and serial number.
Testing:	The unit should be subjected to an endurance test of not less than 2 hours under normal conditions (i.e. warning not lit) and 1 hour with the warning operating.
Acceptance:	The specification, drawings and test evidence should be submitted to the CAA in the first instance for acceptance before the unit is fitted to any aircraft (see also paragraph 8).

5 Installation

The following general guidelines should be used:

- 5.1 The warning lamp should be mounted where it will be readily seen by the pilot. Steady lights will normally need to be mounted in the vicinity of the primary flight instruments whereas those which flash may be acceptable in a less central location.
- 5.2 The low bus voltage warning detector must be connected to the bus system through its own individual fuse or circuit breaker or to one of a suitable rating already fitted to the aircraft for a non-essential service such as a cigar lighter or cabin lighting, etc.
- 5.3 This Leaflet has concentrated on low bus volts monitoring because it is considered the simplest and most effective method, but other means of providing an acceptable alternative could be engineered and these will have to be assessed on an individual basis.

6 Pilot's Instructions

Instructions should be provided in the appropriate manual, such as the Pilot's Notes on the operation of the system and the pilot actions to be taken should the warning operate. A suggested format is attached as an Appendix to this Leaflet. It is recommended that the minimum battery endurance available is specified following the warning and for practical purposes it should be not less than 30 minutes (see Paragraph 7 below).

7 Battery Duration

7.1 Battery endurance can be estimated from either a practical test which involves applying typical aircraft loads for a period of time or by calculation. In either case, only 72% of the name plate capacity should be considered available because of loss of battery efficiency during service and its state of charge. The recommended statement is only intended to give the pilot an estimate of the battery endurance and conditions under which it can be achieved. Furthermore, because it is a relatively broad band estimate it should only be necessary to amend it if a refit with extra electrical loads is carried out.

7.2 An example of how to calculate the duration is given below:

- a) Check the nameplate capacity of the battery and assume 72% is available, e.g. 12 amp-hour = 720 amp-mins.
Thus 72% = 518.4 amp-mins.
- b) Estimate the normal or pre-load shed cruise consumption, e.g. 15 amps (15 amps x 5 mins = 75 amp-mins).
Assuming 5 minutes for pilot to shed essential loads following the low voltage warning.
- c) Estimate the minimum cruise load needed to maintain flight after the generator/ alternator has failed, e.g. 10 amps.
- d) Estimate the consumption required during the landing approach, e.g. 20 amps for 5 minutes (100 amp-mins).

The **cruise** duration is therefore:

$$\frac{\text{Battery capacity a) - [pre-load shed load b) + landing load d)]}{\text{cruise load c)}}$$

$$\frac{518.4 - (75 + 100)}{10} = \frac{343.4}{10} = 34.3 \text{ mins}$$

$$\begin{aligned} \text{Total duration} &= \text{pre-load shed cruise time} + \text{cruise duration} + \text{landing time} \\ &= 5 + 34.3 + 5 \\ &= 44.3 \text{ mins} \end{aligned}$$

8 Modification Status

- 8.1 Installations can normally be approved in accordance with MINOR changes procedures (see EASA Part 21A.95). Any natural and legal person may apply for approval of the change. The application for change classification and approval and the relevant technical documentation should be forwarded to EASA (via the CAA) for review.
- 8.2 Should any company or individual wish to produce a suitable low bus voltage warning detection unit for general use in compliance with GR No. 6, it will be necessary for all documentation to be submitted in the first instance to the CAA Safety Regulation Group, Aviation House, Gatwick, for acceptance of the unit. Individuals who install their own 'one-off' unit must retain the documentation with the aircraft records.

9 Applicability

- 9.1 The requirements will be applicable to aircraft equipped with an engine driven electrical generating system.
- 9.2 GR No. 6 is not applicable to aircraft operating on a Permit to Fly.

10 Further Information

Further information and advice on the contents of this Leaflet may be obtained by contacting the CAA at the following address:

Avionic and Electrical Systems Section
Airworthiness Evaluation and Surveillance Department
Safety Regulation Group
Aviation House
Gatwick Airport South
West Sussex, RH6 0YR

Telephone: +44 (0)1293 567171 (Switchboard)

Fax: +44 (0)1293 573999

APPENDIX

<ORGANISATION IDENTIFICATION>

Flight Manual/Pilot's Operating Handbook Reference: <XXXXXXXXXX>**Supplement No.** <XXXXXX>**Issue:** <XX>**Aircraft Type:** <XXXXXXXXXX>**Registration Mark:** <XXXXXX>**Aircraft Serial No:** <XXXXXXXX>**ADDITIONAL LIMITATIONS AND INFORMATION FOR CERTIFICATION**

The limitations and information contained herein either supplement or, in the case of conflict, override those in the flight manual.

LOW BUS VOLTS WARNING

A steady/flashing warning light is installed which will illuminate if the generator/alternator output reduces to a level where the battery supplies power to the bus-bar.

Before engine start

Check low volts warning – ON

After engine start

Check low volts warning – OFF

If warning illuminates during flight

Reduce electrical load

Battery duration approx. mins

Land as soon as possible.

NOTE: Warning may illuminate with low engine rpm. Check it goes out when rpm increased.

Approved as part of minor modification no. <XXXXXXXX>**EASA Approval no.** <XXXXXXXXXX>**Date:**

Chapter 25 Equipment/Furnishings

Leaflet 25-10 Lifejackets

1 Introduction

This Leaflet provides guidance and advice on the inspection and maintenance of lifejackets, which are required to be carried in certain aircraft operating under conditions specified in the Air Navigation Order (ANO). Owing to the wide variety of lifejackets, the information is of a general nature and does not apply to any particular make or type of lifejacket. The maintenance and servicing of the less common types of survival equipment are very similar to the single inflation chamber type covered by this Leaflet.

2 General

- 2.1 Lifejackets are designed as lightweight items of equipment and as such should be treated with care. Lifejackets are normally packed in specially made valises or containers for ease of handling and these also protect the lifejacket; they also help to keep the lifejacket correctly folded, to facilitate donning. However, care should be taken not to drop a packed lifejacket or to place loads upon it. Manufacturers often recommend that a lifejacket which has been subjected to such abuse or has been immersed in sea water, should be rejected for further operational use.
- 2.2 The necessary instructions for fitting lifejackets are displayed in the aircraft and, in many instances, these instructions are repeated in safety pamphlets for distribution to individual passengers. Similar information may also be given on the lifejacket by means of special adhesive labels or stencilling on the surface of the jacket.
- 2.3 Passenger lifejackets are usually stowed either under seats or armrests. Crew life jackets are stowed in easily accessible positions. Stowages should be kept clean and dry and the stowage retaining device should be checked periodically for security and ease of release.
- 2.4 Lifejackets which have been used for demonstration by crew members should be returned for inspection as if they were time expired. To ensure that this is always done, the demonstration lifejackets should be kept out of the normal stowage and a suitable warning label should be attached.

3 Lifejackets – General Description

- 3.1 There are several types of lifejackets in use and all are basically similar. Buoyancy is obtained by inflating the jacket with carbon dioxide (CO₂) gas, which is stored under pressure in a small cylinder and released by means of a manually operated mechanism. A standby mouth inflation valve is also provided in case the CO₂ system is inoperative, or if it is necessary to 'top-up' the pressure after a long period of immersion. To assist rescue operations, lifejackets are equipped with an identification light, battery and a whistle is also provided. Certain types of lifejackets may also carry additional equipment such as fluorescent sea marker dye, shark repellent products and special signalling devices.

NOTE: Care should be taken to avoid unintentional operation of the inflation mechanism. The mechanism cannot be used to stop the gas flow, which will inflate the lifejacket in a few seconds. However, if the lifejacket is inadvertently inflated, means are provided for deflation. This can be effected on some lifejackets by depressing the non-return valve in the mouthpiece, by means of a deflation key stowed next to the mouth inflation valve and secured to the lifejacket by an attachment cord, or by inserting the extension piece moulded on to the side of the valve protection cap.

- 3.2 Most lifejackets are of the single inflation chamber type as illustrated in Figure 1, but there are others which have more than one inflation chamber, gas cylinder and mouth inflation facility; some aircraft may also carry baby flotation survival cots.

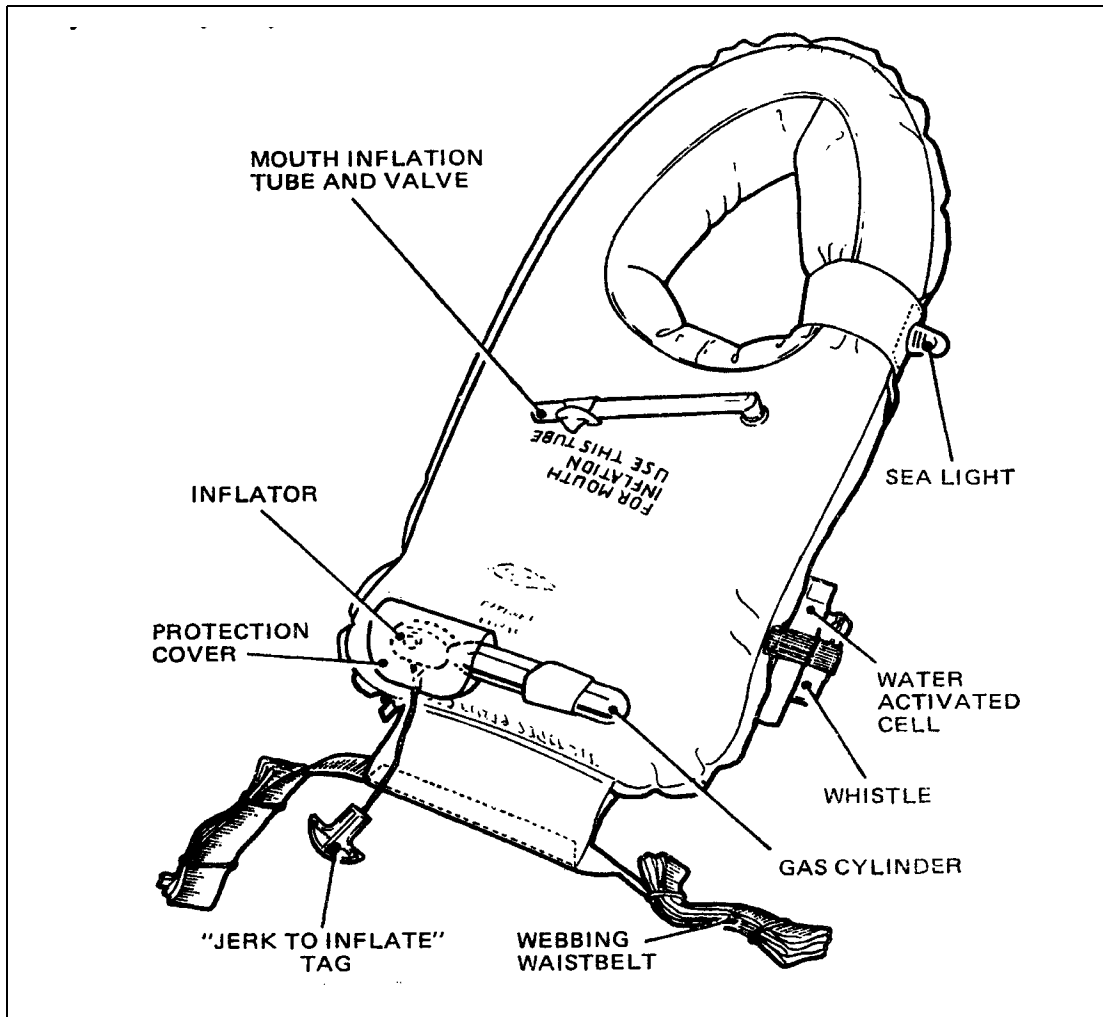

Figure 1 Typical Lifejacket

- 3.3 The material used for fabricating lifejackets is generally either rubberised cotton or polyurethane coated nylon (coated on either one or both sides), the panels being joined by the use of an adhesive or by welding.
- 3.4 A light unit is attached to a lifejacket in such a way as to ensure that, when the lifejacket is in use, the lamp assembly will be in a prominent position. The bulb is connected by means of a plastic covered lead to a battery, which is usually water activated and located below the water line. Operation of the battery is achieved by the ingress of water into the cell.
- 3.5 The operating mechanism into which the CO₂ cylinder is fitted consists of a housing containing a piercing pin which, when pushed forward by a cam-type operating lever,

pierces a sealing disc in the neck of the cylinder, allowing gas to flow past a non-return valve into the lifejacket. The piercing pin is actuated by pulling a red knob or tag, which is attached by a cord or chain to the operating lever.

4 Maintenance Requirements

4.1 The appropriate manufacturer's publication will stipulate the periods at which inspections and related tests are required and will also give full details of the inspection and test operations involved. It may stipulate inspection after every 6 months of service life, with a more comprehensive inspection after every 18 months, or it may stipulate a yearly inspection only. Similar information will also be given regarding accessories, such as CO₂ mechanisms, identification lights, inflation valves, etc. The lifejacket and some of the accessories (e.g. CO₂ cylinder), will also have a maximum service or storage life, stipulated in years, which must not be exceeded. All work should be carried out in accordance with the relevant publications and the lifejacket and inflation equipment manufacturers' Service Bulletins, etc. All details of a particular lifejacket, including modifications and inspections and the Inspector's stamp or signature, should be recorded on an Inspection Record kept at the maintenance base.

4.2 Inspection Facility

4.2.1 Inspections and tests should be carried out in clean premises kept at stable room temperature. To avoid damage through puncture or abrasion, the inspection tables should have smooth, well finished surfaces free from any wood splinters or sharp corners and the working surfaces should be kept thoroughly clean. Precautions should be taken to avoid any contact with oil, grease or acid.

4.2.2 A rack should be provided from which lifejackets under inflation test can be suspended and a method of referencing should be adopted to relate each lifejacket with the time of inflation and the duration of the test period. The rack should be kept away from direct sunlight or radiated heat.

NOTE: All inflation tests must be carried out under stable temperature conditions.

4.2.3 To trace leaks in lifejackets which have failed to maintain the required test pressure, an immersion tank containing clean water is often used. In other instances, the suspected area is smeared with an acid-free soap solution, all traces of which should be thoroughly removed by rinsing with lukewarm water immediately after test.

4.2.4 Laboratory type scales having an accuracy of 0.1 gramme should be available for cylinder gas-charge checks.

5 Inspections and Tests

5.1 Lifejacket

5.1.1 The lifejacket should be withdrawn from its valise, unfolded and equipment such as the CO₂ cylinder, identification light assembly and whistle removed. A check of the serial number marked on the lifejacket and that on the related Inspection Record should be made. All instructions stencilled or labelled on the lifejacket should be examined for legibility. Such information as date of manufacture, modifications embodied, etc., must agree with the Inspection Record.

NOTE: In some instances it may be necessary to clean the lifejacket before inspection. This should be done with lukewarm water and the cleaning agent recommended by the manufacturer.

5.1.2 Inspection

The proofed fabric should be inspected for slits, tears, holes, adhesion of seams and general deterioration. Deterioration is seldom immediately apparent and can easily be overlooked. It is vitally important therefore, that a careful inspection for any of the following signs should be made:

- a) Discoloured areas (not due to surface dirt which can be washed off).
- b) Sticky areas.
- c) Hard or stiff areas.
- d) Shiny areas.

5.1.3 Webbing, elastics and cordages should be inspected for discoloration, deterioration and security of attachment (e.g. condition of stitching and security of knots).

5.1.4 Metal and plastics components should be inspected for cleanliness, damage or deterioration and security (e.g. adhesion of components to fabric where applicable).

5.1.5 Inflation Tests

Inflation tests are required to check a lifejacket for leaks and may be carried out after repairs have been made, to check the buoyancy chamber, or after the gas cylinder has been inspected and reassembled, to check the complete jacket. The lifejacket is inflated using a test rig, which may be connected either to the mouth inflation valve or to the operating head (with the gas cylinder removed), depending on the reason for the test.

NOTE: Before tests are commenced the test equipment should be checked for leaks, especially at the connections.

5.1.6 The initial test consists of inflating the lifejacket to a given pressure and allowing the pressure to stabilise with the air supply disconnected. After a given time, the pressure is checked to ensure that it has not dropped below a specified figure.

NOTE: The lifejacket should not be touched whilst on test as the pressure reading may be affected.

5.1.7 If the initial test is satisfactory, the lifejacket is re-inflated and allowed to stand for a longer test period, after which the pressure should not have dropped below a second stipulated figure.

5.1.8 Whilst the lifejacket is inflated a visual examination should be made for any signs of distortion or damage not revealed before inflation.

5.1.9 If any stage of the test proves unsatisfactory, leakage may be traced by either of the methods outlined in paragraph 4.2.3, when air bubbles will indicate the position of the leaks. Local repairs may often be carried out, but where damage exceeds limits specified in the relevant manual, the lifejacket should be returned to the manufacturer (see paragraph 6).

5.1.10 The mouth inflation valve will also require pressure testing for leaks, either by placing a small amount of water in the mouthpiece or by immersing the valve unit in water and checking for the presence of bubbles. A valve functioning test may be specified; this is done by applying air pressure to the mouthpiece and ensuring that the valve opens at a specified pressure below the working pressure of the lifejacket. If the valve should leak, or if it fails to open at the functioning pressure specified, the following actions should be taken depending on the type of valve:

- a) With the type of valve which can be disassembled, this should be done and the valve should be cleaned and its seat checked for deterioration or dirt and then

lubricated with a silicone grease specified by the manufacturer. After re-test, if the valve still leaks it should be replaced by a new assembly and again tested.

- b) With the type of valve which cannot be disassembled, it should be renewed in accordance with the instructions contained in the relevant Overhaul Manual.

5.2 **Light Unit**

5.2.1 **General**

The life of the light unit is often indefinite, provided that periodic inspections and tests prove satisfactory.

5.2.2 **Inspection**

The battery should be inspected for any signs of damage or deterioration, or for signs of chemical reaction indicated by the presence of a white powdery deposit or bulging of the battery case.

- 5.2.3 It is also important to ensure that no activation has taken place due to the ingress of moisture. Depending on the design of the battery it is often possible to check for activation visually. With some types this may be done by holding a source of light at the base of the battery case and looking through the water holes at the top. It should be possible to see clearly through the holes but if any activation has taken place the holes will be obstructed.

- 5.2.4 When fitting water-activated batteries into stowages on the lifejackets, care is necessary to ensure that the instructions regarding the removal of the water sealing plugs or other sealing devices are carefully followed, as they will vary with the type of battery used.

5.2.5 **Electrical Tests**

Electrical tests for the water-activated type of battery are usually prescribed. They often consist of testing with a standard aircraft insulation resistance tester connected across the battery terminals to obtain a specified reading in megohms (e.g. 1 megohm minimum). A milli-voltmeter test is also often acceptable; with the milli-voltmeter across the battery terminals, no voltage should be registered.

NOTE: When testing with a milli-voltmeter, an initial test should be made at a higher scale reading to obviate damage to the meter should the battery be active.

- 5.2.6 The electrical circuit and the bulb should be checked for electrical continuity and functioning using a slave battery of the correct voltage.

5.3 **Gas Cylinders**

- 5.3.1 The CO₂ cylinders should be carefully inspected for any signs of damage such as dents, scores or corrosion, which would weaken the cylinder and render it unserviceable and possibly dangerous. The cylinder threads should also be checked for obvious signs of damage.

- 5.3.2 With the operating mechanism removed, the CO₂ cylinder should be checked for correct gas charge by weighing. Some cylinders are marked with the empty weight and the weight of the gas charge is given in the appropriate publication; later cylinders are marked with the total (charged) weight, e.g. TW. 146. Should the cylinder be found to be outside the weight limitations it should be replaced by a fully charged one.

- 5.3.3 All CO₂ cylinders are 'lified' and should be returned to the manufacturer for inspection and test when their life has expired. A code representing the date of manufacture, or the actual date of manufacture of a cylinder, is stamped on its base and this should be checked during inspection.

5.4 **Operating Mechanism**

- 5.4.1 With the CO₂ cylinder removed, the inspection instructions usually stipulate a functioning check to ensure the correct travel of the piercing pin and in some cases the mechanism is disassembled and all parts cleaned and inspected at specified intervals. Damaged or corroded metal parts and seals or rubber washers showing any signs of deterioration should be renewed if permitted by the manufacturer.
- 5.4.2 On some lifejackets the operating mechanism is mounted on a rubber base and the unit is bonded to the lifejacket; no attempt should be made to separate this bond. Care is therefore necessary to avoid damage to the attached lifejacket when work is carried out on the operating mechanism.
- 5.4.3 After reassembly of the operating mechanism a final check should be made to ensure that the operating lever is in the correct position (i.e. cocked) and that the safety retaining device (e.g. break thread or spring clip) has been properly fitted.
- 5.4.4 In the event of the mechanism having been immersed in sea water, it should be disassembled, checked for corrosion and then thoroughly cleaned to remove all traces of salt deposit.

6 **Repairs**

6.1 **General**

The parts of a lifejacket which are made from proofed fabric are liable to suffer from damage or deterioration and repair schemes and instructions are often contained in the relevant Overhaul Manual. In the case of lifejackets which are joined by an adhesive, extensive repairs are often permissible within limits specified by the manufacturer, but in the case of lifejackets which are joined by welding, only minor patch repairs are usually permitted. This is because the machine settings have to be predetermined for each tool and type of weld and it is unlikely that a lifejacket servicing facility other than the manufacturer could carry out satisfactory welded repairs.

6.2 **Repair Limitations**

- 6.2.1 Repairs are carried out by patching with a material identical to or compatible with that used in the original lifejacket, using a self-vulcanising solution as the adhesive. Repairs are to be carried out within the limitations contained in the relevant Overhaul Manual.
- 6.2.2 Patches should be circular, or rectangular with rounded corners and should overlap any damage by at least 25 mm (1 in). Reinforcing strip should overlap the existing strip by at least 25 mm (1 in) and exterior tape should overlap by 50 mm (2 in).
- 6.2.3 The repair solution is supplied as a kit and contains a number of ingredients which must be mixed strictly in accordance with the manufacturer's instructions. Once mixed the solution must be used within a few hours, as it soon becomes unstable.
- 6.2.4 All tools and utensils used when carrying out repairs, e.g. roller, brushes and spatula, should be kept scrupulously clean and free from abrasions.
- 6.2.5 In some cases it may be recommended that a test piece should be prepared using the fabric and adhesive used for the repair, in order to check the progress of vulcanisation. At the end of the vulcanising period (2 to 4 days) a portion of the test piece should be peeled apart and a few drops of an appropriate solvent applied to the surface. If vulcanisation is complete the liquid will spread quickly and be absorbed, but if not it will be absorbed slowly and the surface will be tacky.

6.3 Repair Procedure

- 6.3.1 Because of the different methods of manufacture of lifejackets, damage could be caused by using inappropriate repair procedures. As an example, some fabrics are proofed on the outside only, whilst others are proofed on the inside only; abrading the former is an essential part of the repair procedure, whereas abrading the latter would weaken the fabric and cause further damage. It is essential, therefore, that the manufacturer's instructions concerning the repair of a particular lifejacket are carefully followed and any related safety precautions are observed.
- 6.3.2 After repairs have been carried out the lifejacket should be tested as outlined in the Overhaul Manual.

7 Final Assembly

7.1 General

After all the inspections, repairs and tests have been satisfactorily completed and before the lifejacket is folded, a careful check should be made to ensure that all the related equipment has been correctly assembled and fitted to the lifejacket in accordance with the instructions for the type concerned.

7.2 Folding

- 7.2.1 The folding instructions will vary in detail with different types of lifejacket, or in some instances with similar types fitted with different equipment. Care is necessary to ensure that all air has been expelled from the lifejacket before folding.

NOTE: On some lifejackets a deflation key is fitted to the mouth inflation valve to ensure that all air is expelled; this key must be removed before the lifejacket is folded.

- 7.2.2 After inspecting the valise or container for cleanliness and damage, the lifejacket should be inserted and the closure secured.

- 7.2.3 A tie-on label giving the serial number of the lifejacket and the date of the next inspection due should be attached, or when a pocket is provided in the valise, a card giving similar information should be inserted.

NOTE: When a tie-on label is used, the quality of the label and the attaching cord should be such that they cannot be damaged or become detached whilst the lifejacket is in service. Some instances have arisen where lifejackets have been transferred from one aircraft to another and the label(s) have become detached. This has necessitated unpacking and checking against the base Inspection Record to ensure that the inspection date had not expired.

8 Storage

Leaflet D-40, Storage Conditions for Aeronautical Supplies, gives guidance on acceptable conditions for the storage of lifejackets.

INTENTIONALLY LEFT BLANK

Leaflet 25-20 Use of Electrically Powered Medical Equipment on Aircraft

1 Purpose

This Leaflet provides information and guidance concerning the methods and procedures required to achieve the acceptance for carriage and use of electrically powered medical equipment on board aircraft. This information does not represent the official European Aviation Safety Agency (EASA) policy. However, the information provided in this Leaflet has been used by the UK CAA and is considered to be useful guidance material for the evaluation of electrically powered medical equipment.

2 References

Commission Regulation (EC) No 1702/2003 Annex Part 21 – Certification of aircraft and related products, parts and appliances, and of design and production organisations

CS-23 – Certification Specification for Normal, Utility, Aerobatic, and Commuter Category Aeroplanes

CS-25 – Certification Specification for Large Aeroplanes

CS-27 – Certification Specification for Small Rotorcraft

CS-29 – Certification Specification for Large Rotorcraft

CS-VLA – Certification Specification for Very Light Aeroplanes

CS-VLR – Certification Specification for Very Light Rotorcraft

EUROCAE ED-14, RTCA DO-160 [Applicable Version] – Environmental Conditions and Test Procedures for Airborne Equipment.

BS 2G 239 – Specification for Primary Active Lithium Batteries for use in aircraft

AIC 1/2004 (Pink 62) – Use of Portable Electronic Devices in Aircraft

3 Introduction

This Leaflet provides information and guidance concerning the approval of installations of electrically powered medical equipment and methods of gaining the acceptance to carry and use portable electrically powered medical equipment on board aircraft.

The procedures outlined cover the use of electrically powered medical equipment either installed as part of the cabin equipment or carried on board the aircraft as part of the aircraft emergency equipment.

4 Approval Considerations

An approval assessment will be necessary to demonstrate that the equipment, its installation, and operation will not adversely affect proper functioning of the aeroplane systems and equipment required for type certification or by the operating rules, or whose operation would reduce safety. In addition, it shall not affect the safety of the flight crew, cabin crew or other passengers. It should be noted that the UK CAA or

EASA would not endorse any assessment of the functionality of the item of medical equipment.

The approval is therefore based upon a 'no hazard, no credit' assessment in that the equipment is assessed purely on the basis that it introduces no hazard to the aircraft or occupants, but that no credit is given to its functionality.

The procedure to be used for the approval or acceptance of the introduction of electrically powered medical equipment to the aircraft is that which is covered within European Commission Regulation No. 1702/2003 Annex Part 21 by a design change to the aircraft. This is accomplished by the introduction of a change to the aircraft's Type Certificate (TC) by the TC holder, or by the introduction of, or by a change to, a Supplemental Type Certificate (STC).

Equipment is therefore accepted for use on an aircraft using the requirements set out in Part 21 Subparts D or E.

5 No Hazard Aspects

The EASA Certification Specifications for aircraft are used to demonstrate compliance with the Basic Regulation (Regulation 216/2008) and its implementing rules (Regulation 1702/2003). These include airworthiness codes, which are standard technical interpretations of the airworthiness essential requirements contained in Annex 1 to the Basic Regulation; and acceptable means of compliance, which are non-exclusive means of demonstrating compliance with airworthiness codes or implementing rules.

The Certification Specification for large aeroplanes requires that equipment and systems be designed and installed so that those equipment and systems that are 'required' for type certification or by the operating rules, or whose improper functioning would reduce safety, perform their intended function under all aeroplane operating and environmental conditions. In addition, it requires that all other equipment and systems, within which category electrically powered medical equipment would fall, are not a source of danger in themselves and do not adversely affect the proper functioning of the 'required' equipment, defined above. Similar requirements exist for other aircraft categories, within their respective Certification Specifications.

This requires that it is established by analysis and/or tests that the medical equipment will not present a hazard to the aircraft and its occupants under normal operation or under fault conditions.

The following provides a summary of many of the subjects pertinent to the safety of the aircraft, its occupants and maintenance personnel, which the electrically powered medical equipment manufacturer should consider and the equipment installer needs to address.

5.1 Equipment Evaluation

The installer's evaluation of the electrically powered medical equipment should consider hazards/issues such as flammability, smoke generation, explosion, EMC, magnetic interference, risk of electric shock, risk of burns, safety of cathode-ray tubes, aircraft depressurisation, fluid exposure, electrical bonding, gaseous concentrations, toxicity, battery issues, mechanical integrity etc.

Environmental conditions and test procedures normally specified for airborne equipment are defined in EUROCAE ED-14, RTCA DO-160 [Applicable Version]. This

document should therefore be used as guidance material and where possible, compliance with this document should be shown, as applicable.

If items of equipment have previously been tested to an alternative standard, a comparison against the categories in EUROCAE ED-14, RTCA DO-160 [Applicable Version] can be made by the applicant.

Environmental qualification of an item of equipment to a set of categories in EUROCAE ED-14, RTCA DO-160 [Applicable Version] does not imply approval or acceptance for the use of the equipment in a particular aircraft environment. The equipment installer should satisfy himself that the declared equipment environmental standards are appropriate to the environments in the aircraft to which the equipment is to be fitted and operated.

5.1.1 **Fire, Smoke, Fumes and Explosion**

The risk of the equipment exploding, catching fire or producing noxious or toxic fumes, or smoke, should be reduced to a minimum. It should be noted that even small quantities of smoke can be alarming to passengers and could lead to irrational behaviour. Particular attention should be directed to the design and quality of wire wound components, motors and pressure vessels, so as to minimise the risk of overheating. Consideration should also be given to the types of protective coatings used on components and assemblies.

It should be established that the stalling of any drive motor would not cause fumes, smoke or overheating.

Materials used in the equipment should meet the applicable fire test criteria defined in the CS equipment requirements or equivalent.

5.1.2 **EMC**

The levels of Radio Frequency (RF), electrical and magnetic emissions generated by the equipment should not cause an adverse effect to the performance of the required aircraft systems.

It should be demonstrated that the equipment complies with the relevant categories of EUROCAE ED-14, RTCA DO-160 [Applicable Version] or equivalent.

5.1.3 **Electric Shock**

The risk of electric shock should be reduced to a minimum. Particular attention should be directed to high voltage equipment and to cathode-ray tubes. Where there may be a hazard during maintenance or servicing, equipment operating with voltages above 50 V r.m.s. should be marked with the voltage or suitably placarded with high voltage warnings. Particular care should be taken with defibrillation equipment (Automatic External Defibrillator, etc.), which by its nature, is designed to provide a controlled electric shock to the casualty.

5.1.4 **Burns**

The risk of burns should be reduced to a minimum. Particular attention should be directed to lamp assemblies and the heatsinks of equipment packages. Hot surfaces should not be exposed where inadvertent contact may be a hazard.

5.1.5 **Cathode-Ray Tubes**

Equipment containing cathode-ray tubes should be so designed and installed that the risk of harmful exposure to X-rays and to injury as a result of implosion are reduced to a minimum.

5.1.6 **Aircraft Depressurisation**

Where high voltages are present within the equipment, it should be established that no arcing that would cause a fire risk or unacceptable levels of emission will occur within the equipment when it is subjected to an atmospheric pressure equivalent to the maximum operating altitude of the aircraft. Alternatively, means would have to be provided to automatically disconnect the electrical supply to or of the equipment when the cabin pressure reduces to a level beyond which the safe operation of the equipment is not assured. Particular attention should be paid to hermetically sealed enclosures that may be subjected to differential pressures.

5.1.7 **Fluid Exposure**

Where the equipment is mounted in a position where exposure to fluid is possible, it should be established that fluid spillage does not cause the equipment to become hazardous. The fluid susceptibility should be declared as part of the general environmental specification of the equipment. EUROCAE ED-14, RTCA DO-160 [Applicable Version] or equivalent would be applicable.

5.1.8 **Electrical Bonding**

The electrical bonding and protection against static discharge of the equipment should be such as to:

- a) Prevent dangerous accumulation of electrostatic charge; and
- b) Minimise the risk of electrical shock to crew, passengers and servicing personnel.

The equipment earthing arrangements should be adequate for the conduction of any current, including fault current, and be in accordance with the applicable aircraft standards.

Applicants should adhere to the relevant recommendations for bonding, grounding, shielding and other methods to eliminate and control Electrostatic Discharge (ESD).

5.1.9 **Gaseous Equipment**

Gaseous equipment should be evaluated in order to check for adequate safety devices such as pressure relief valves etc. Pipes and vessels should be tested to a safety margin of at least 2.5 Proof and 3.0 Ultimate times the normal working pressure. (See CS-25 Appendix K). The build up of gases within the aircraft, as a result of normal operation or equipment fault conditions, should be prevented.

5.1.10 **Mechanical Integrity**

Equipment, attachments and supporting/stowage structure should be constructed such that the equipment and constituent parts are retained when subjected to the following load factors:

- a) Load factors for emergency alighting (Considered as Ultimate) as defined by paragraph 561 in CS codes 23 and 25 for Aeroplanes and 27 and 29 for Rotorcraft. (It should be noted that the load factors specified in CS 23.561 are particularly severe (applicable to Aeroplanes below 5700 kg)).
- b) The Ultimate flight inertia factors for the aircraft type considered.

In principle the significant flight cases will be:

- i) Vertical gust and Pitch manoeuvres resulting in vertical and drag inertia factors; and
- ii) Lateral Gust, Yaw and Roll manoeuvres which result in combined Inertia Factors in the vertical, lateral and drag directions.

5.1.11 **Equipment Location**

The equipment should be located such that it does not present a hazard to evacuating the aircraft under emergency conditions.

5.1.12 **External Surfaces**

The external surface of the equipment should not present a hazard due to sharp corners and rough edges etc.

5.2 **Aircraft Evaluation**

Aircraft tests should be performed on the particular aircraft variant on which the item of medical equipment is to be used. The purpose of the tests is to ensure that the operation of the electrically powered medical equipment does not adversely affect the operation of the aircraft equipment and systems required for the type certification or by the operating rules, or whose improper functioning would reduce safety.

The electrically powered medical equipment should be operated at every likely location and attitude on the aircraft to determine if there is any particular area where the operation of the equipment should be prohibited. Copies of the relevant Test Schedules should be made available for review as required.

5.3 **Acceptance**

Providing that the outcome of the above evaluation and tests is satisfactory and that the requirements of the appropriate EASA CS and relevant subpart of Part 21 are demonstrably complied with, EASA will be requested to accept the use of the particular item of medical equipment on the aircraft subject to any conditions identified during the exercise and providing acceptable operational and maintenance procedures exist.

This acceptance will be for the evaluated and tested item, identified by equipment type, part number and serial number (or controlled standard), for use on the aircraft tested, identified by type.

The applicant will be required to assess the similarity of any aircraft within type, to that of the variant tested, before the use of the medical equipment on other aircraft could be accepted, noting that this may require a further submission to be made to EASA if the intended use is broader than the scope of the certificated design change, i.e. the aircraft identified within the Design Change (TC or STC) certificate.

6 **Electrical Power**

6.1 **Internally Supplied Power**

The item of medical equipment may be powered by any of the following types of battery:

- a) Sealed Lead Acid type, but not including those with electrolyte in liquid form.
- b) Sealed Alkaline type, but not including those with electrolyte in liquid form.
- c) 'Dry' cell type batteries.
- d) Lithium based batteries, provided that the requirements of CAAIP Leaflet B-180, Appendix 24-6 and BS 2G 239 are complied with.

The charging or re-charging of the equipment batteries should not be permitted within the confines of the aircraft.

Adequate circuit protection should be incorporated to guard against hazardous charge and discharge rates.

The battery should preferably be installed in a container designed to prevent handling damage to the battery itself.

6.2 Aircraft Supplied Power

If the item of medical equipment is to use the aircraft's electrical power supply then appropriate steps should be taken to ensure that the safety and integrity of the aircraft electrical system is not compromised.

Adequate circuit protection should be used to protect the aircraft electrical system and the medical equipment power supply cables.

The installer should satisfy himself that the EUROCAE ED-14, RTCA DO-160 [Applicable Version] (or equivalent) categories chosen for the power supply input of the item of electrically powered medical equipment are compatible with those of the relevant aircraft supplies. Both normal and abnormal conditions should be considered.

Attention should be paid to the electrical loads imposed on the aircraft supplies. Provision should be made to allow the flight crew to shed or isolate the aircraft supply to the electrically powered medical equipment in abnormal or emergency conditions to limit the electrical load.

7 Design Change Classification

7.1 Changes in type design are classified as minor and major in accordance with Part 21A.91. Examples of how the change classification process might apply to the installation of electrically powered medical equipment are as follows:

- a) The initial assessment conducted to demonstrate that the electrically powered medical equipment, its installation, and operation will not adversely affect proper functioning of the aircraft systems and equipment or occupants, as defined in paragraph 2 of this document, will include an equipment and aircraft level evaluation. The considerable extent of new substantiation data generated might result in this change being classified as Major. Major changes will be implemented in accordance with Part 21A.97. It could normally be expected that this be introduced using Part 21 Subpart E, STC process, although Part 21 Subpart D for the TC process would be equally appropriate.
- b) The introduction of previously approved electrically powered medical equipment to new aircraft types would require the aircraft level evaluation and this would result in a considerable extent of new substantiation data generated that might also result in this change being classified as Major. It could normally be expected that this be introduced using Part 21 Subpart E, STC process, although Part 21 Subpart D for the TC process would be equally appropriate.
- c) Changes or modifications to previously approved electrically powered medical equipment will be assessed in accordance with Part 21A.91. Changes that are classified Minor may be implemented by a Minor design change in accordance with Part 21A.95.

It should be noted that within paragraph c) above, the term "approved" refers to the aircraft level design change that introduces the electrically powered medical equipment to the aircraft. For changes to electrically powered medical equipment that had been issued with a UK CAA BCAR Safety Acceptance (SA) registration certificate

by the UK CAA before 28 September 2003, advice should be sought from the UK CAA or EASA.

8 Operating Procedures and Publications

The appropriate members of the crew of the aircraft need to be fully conversant with the operation of the electrically powered medical equipment.

Procedures should be established and stated clearly to control the medical equipment. These should provide as a minimum the following:

- a) Procedures to limit the operation of the equipment in certain flight phases (e.g. Take-off and Landing) or during abnormal or emergency conditions, if necessary.
- b) Procedures to terminate the operation and/or electrically isolate the system at any time.
- c) Procedures for Flight Deck to Cabin co-ordination to ensure all crew are aware of the use of the equipment at all times.
- d) Procedures for reporting instances of suspected and confirmed interference with the aircraft systems and equipment.

9 Maintenance Provisions

General procedural instructions for equipment testing should be provided to prevent performance degradation that might become a source of hazard.

Maintenance procedures should be specified and observed, e.g. battery checks etc. The maintenance tasks should be included in the maintenance schedule of the aircraft as appropriate.

10 Equipment Performance

As previously stated, neither the CAA nor EASA will endorse any assessment of the functionality of the item of medical equipment.

The following points should however be noted with regards to the equipment performance:

- a) The applicant should ensure by equipment and aircraft evaluation that the item of medical equipment would function as intended in the aircraft environment.
- b) The applicant should ensure that the equipment itself operates satisfactorily when subjected to the electromagnetic environment that would typically be present on board the aircraft.
- c) All maintenance should be carried out in accordance with the equipment manufacturers' instructions to ensure the continued build standard to prevent performance degradation that may affect the functionality of the equipment.

INTENTIONALLY LEFT BLANK

Leaflet 25-30 Electrically Powered Aeroplane Passenger Seats

1 Purpose

This Leaflet provides information and guidance for the approval of passenger seats with electrically powered actuators, which are designed to be installed on civil aeroplanes.

NOTE: This information does not represent official European Aviation Safety Agency (EASA) policy. However, the information presented in this Leaflet has been used by the CAA and is considered to be useful guidance material for the evaluation and approval of electrically powered seats.

2 References

Part 21 – Certification of aircraft and related products, parts and appliances, and of design and production organisations

AMC & GM – Acceptable Means of Compliance and Guidance Material for the airworthiness and environmental certification of aircraft and related products, parts and appliances, as well as for the certification of design and production organisations to Part 21

CS-23 – Normal, Utility, Aerobatic, and Commuter Category Aeroplanes

CS-25 – Large Aeroplanes

CS-ETSO – European Technical Standard Orders:

ETSO-C39b – Aircraft Seats and Berths

TSO-C39c – 9g Transport Airplane Seats Certified by Static Testing

TSO/ETSO-C127a – Rotorcraft, Transport Aeroplane, and Normal and Utility Aeroplane Seating Systems

EU-OPS (formerly JAR-OPS 1) – Commercial Air Transportation (Aeroplanes)

JAA TGL Leaflet No 17 – Passenger Service and In-Flight Entertainment (IFE) Systems

JAA TGM/25/10 – Temporary Guidance Material regarding the Installation of In-Seat Power Supply Systems (ISPSS) for Portable Electronic Devices (PED)

ARINC 628 Part 1&2 – 'Cabin Equipment Interfaces' dated Dec 27 1993

EUROCAE ED-14(), (RTCA DO-160()) – 'Environmental Conditions and Test Procedures for Airborne Equipment'

EUROCAE ED-12B, (RTCA DO-178B) – 'Software considerations in Airborne Systems & Equipment Certification'

RTCA document DO-199 – 'Potential interference to aircraft electronic equipment from devices carried aboard' dated Sept 16th, 1988

RTCA document DO-223 – 'Portable electronic devices carried on board aircraft'

FAA AC 21-25A – Approval of Modified Seating Systems Initially Approved Under a Technical Standard Order

3 Introduction

Passenger seats, particularly those in First and Business Class environments, are becoming increasingly complex. In addition to being fitted with Cabin Service and In-Flight Entertainment (IFE) Systems, they may contain a number of electrical actuators and associated control systems to provide such features as powered recline and conversion into beds. Presented in this Leaflet are general criteria for the approval, modification and continued airworthiness of such seats installed in aeroplanes. Although specifically written to address seats with electrical power, many aspects of this Leaflet are applicable to seats that are manually operated. This Leaflet is not applicable to Cabin Service and IFE Systems for which guidance is available in JAA TGL Leaflet No. 17; nor is it applicable to In-Seat Power Supply Systems for which guidance is available in JAA TGM/25/10.

4 Approval Consideration

All seats will need to be approved in accordance with Part 21 Subpart K (Parts and Appliances), in conjunction with the Type Certification procedures of Part 21 Subpart B, D, or E, or alternatively approval may be granted by a European Technical Standard Order Authorisation (ETSO) if the applicant meets the requirements of Part 21 Subpart O. When the equipment has been approved by the CAA, an acceptable installation will be required to be demonstrated by the installer showing that it is in accordance with appropriate Certification Specifications and that proper account has been taken of the equipment manufacturer's Declaration of Design and Performance and installation instructions. Part 21 Subpart O gives guidance for the preparation and format of the Declaration of Design and Performance. Specific guidance on the information to be included in a DDP for an electrically powered passenger seat is included in Section 4.2 of this Leaflet.

It should be noted that the current ETSO C39b, TSO C39c and ETSO C127a do not contain electrical requirements. Therefore, for seats that contain electrical in-seat equipment, an ETSO approval alone would not be sufficient to demonstrate suitability for installation on an aeroplane. The electrical aspects of the seat also need to be addressed.

4.1 Applicable Requirements

The following list is for guidance purposes only and is not exhaustive, the applicable airworthiness requirements will depend on the aeroplane in which the passenger seat is to be installed. Where CS 25 has been referenced, similar requirements can, in most cases, be read across to CS 23.

- EU-OPS 1.320 Seats, safety belts and harnesses
- EU-OPS 1.825 Life Jackets
- EU-OPS 1 Subpart M Aeroplane Maintenance
- CS 25.561 General (Emergency Landing Conditions)
- CS 25.562 Emergency Landing Dynamic Conditions
- CS 25.785 Seats, berths, safety belts and harnesses
- CS 25.787 Stowage compartments
- CS 25.789 Retention of items of mass in passenger and crew compartments and galleys

- CS 25.815 Width of aisle
- CS 25.817 Maximum number of seats abreast
- CS 25.853 Compartment interiors
- CS 25.869 Fire protection: systems
- CS 25.899 Electrical bonding and protection against lightning and static electricity
- CS 25.1301 Function and installation
- CS 25.1309 Equipment, systems and installations
- CS 25.1351 General (Electrical Systems and Equipment)
- CS 25.1353 Electrical equipment and installation
- CS 25.1357 Circuit protective devices
- CS 25.1360 Precaution against injury
- CS 25.1411 General (Safety Equipment)
- CS 25.1431 Electronic Equipment
- CS 25.1501 General (Operating limitations and information)
- CS 25.1529 Instructions for Continued Airworthiness
- CS 25.1541 General (Markings and placards)
- CS 25 Subpart H Electrical Wiring Interconnection System
- CS 25 Appendix F (Flammability)
- CS 25 Appendix H Instructions for Continued Airworthiness
- CAP 747 Generic Requirement GR No. 2 Minimum Space for Seated Passengers
- CAP 747 Generic Requirement GR No. 3 Access to and Opening of Type III and Type IV Emergency Exits

4.2 **Declaration of Design and Performance (DDP)**

A DDP will need to be produced in accordance with the requirements of Part 21. It is essential to include compliance references to both mechanical and electrical requirements and state limitations and responsibilities. A summary of the key requirements that the DDP will need to address is produced below.

4.2.1 **Electrical**

The DDP will need to define the in-seat electrical equipment by reference to applicable drawings, system analysis and design specifications. The drawings, analysis and specifications should include information such as performance data, dimensions and weight, wiring and connector types, installation methods and wiring routes, seat electrical load, and seat functional hazard analysis.

Electrical equipment and wiring used will need to demonstrate compliance to the applicable airworthiness requirements and their amendments. This may be achieved by making references to test or substantiation reports. Any known operation limitations such as restrictions in mounting attitude or cooling requirements of electronics units and motors will need to be declared.

If the in-seat equipment is not approved as part of the seat, the responsibilities of the seat manufacturer and the in-seat equipment manufacturer will need to be clearly defined in the seat DDP, e.g. the seat manufacturer may be responsible for installation of the in-seat wiring harness and providing suitable mounting provisions

(including aspects such as cooling and attachment strength) for the in-seat IFE equipment.

Consideration should be given to the possibility of electrical faults and the method used to isolate an electrical fault. If applicable, consideration should be given to the provision of a facility to isolate an individual seat or a seat row. Such a facility will enable cabin crew to isolate faults locally rather than having to disable other 'healthy' seats. In the event of an emergency, only the faulty seats would require the attention of the cabin crew thereby reducing the emergency drill time.

If the seat control functions are to be integrated into other systems, e.g. IFE system, that are not the responsibility of the seat manufacturer, and are not approved as part of the seat, then the interface requirements between the seat and the seat control functions have to be clearly defined. The seat DDP should also define the limitations and responsibilities of the seat manufacturer and the organisation that designs and manufactures the seat control functions, as well as references to the evidence that demonstrates adequate interface control. An Electrical Interface Control Document (Electrical ICD) should be supplied by both the seat manufacturer and also the supplier of the seat controls (if different), which clearly defines the electrical control aspects of the seat.

Consideration should also be given to the Electrical Wiring Interconnection System (EWIS) requirements of CS 25, Subpart H (25.1701 to 25.1731 inclusive).

A DDP shall declare the flammability characteristics of the electrical items and their performance in various environmental conditions. As with any items installed in aircraft, in-seat electrical items are required to comply with the applicable flammability requirements such as CS 25.853 for large aeroplanes and in addition, to demonstrate acceptable environmental performance. An acceptable means of showing compliance would be to provide compliance statements against EUROCAE ED-14 (RTCA DO-160), 'Environmental Conditions and Test Procedures for Airborne Equipment', Section 4 to Section 25 (inclusive). These statements should include the applicable equipment categories, test levels and test results as defined in the EUROCAE ED-14.

NOTE: New equipment should always be assessed against the latest issue of EUROCAE ED-14.

If applicable, a statement of criticality of software as defined in the latest issue of EUROCAE ED-12 (RTCA DO-178) is required. Any compliance statement will need to be stated with references to test or substantiation reports.

4.2.2 **Mechanical override**

To aid cabin crew operation, particularly in an emergency situation, consideration should be given to design features such as a mechanical override mechanism and visible indication for TTL (Taxi, Take-off and Landing) position. The seat override mechanism should be able to be operated by cabin crew through appropriate and realistic training. The complete process should be quickly and easily implemented by one person. Particular attention should be addressed to avoiding hidden manual controls and multiple actions. The time to achieve override may need to take into consideration the number of seats in the aircraft and the number of cabin crew available in the context of an emergency. Where the seat has a particular TTL position or range of positions, the cabin crew should be provided with adequate quick-reference visual indication such as an electrical indicator light or mechanical tab. The indication should be clearly visible from the aisle and should provide a definite indication to the cabin crew that the seat is in the TTL position.

5 Installation

It is the Design Organisation that is installing the seat on the aeroplane that is responsible for ensuring that all the declared limitations are complied with. Installation details for the seat should identify fault isolation characteristics and how this relates to the aircraft installation. This may include facilities for isolating an individual seat, group of seats and all seats. Consideration should be given to the effects of fault isolation with respect to cabin crew operating procedures. If the aircraft installation includes a control switch in the flight deck, the flight crew operating procedures should also be considered.

6 Identification and Documentation

Equipment which has been shown to meet the approval requirements of Section 4 has to be so identified. The labelling should be in accordance with the specification of the approval obtained.

A Component Maintenance Manual (CMM) will need to be provided when application for approval is requested. It should provide adequate instructions and information to ensure that the correct replacement equipment and parts are used, and that any maintenance necessary to ensure continued compliance with the safety standards is performed at appropriate intervals.

Adequate documentation should be provided to establish the responsibilities of the seat manufacturer, the in-seat system equipment manufacturer and the seat control equipment manufacturer (if the seat manufacturer is not responsible). The seat manufacturer will need to declare in the seat release documentation that the introduction of the in-seat equipment will not invalidate the seat approval. If applicable, the electrical interface control documentation for the seat and the seat control functions should be provided.

A Functional Hazard Analysis (FHA) should be carried out to identify possible failure modes of any installed electrical apparatus, including required safety objectives. As well as effects on the aeroplane and its system, the analysis should also consider effects on passengers if un-commanded seat movements occur. This information will assist in the preparation of operational procedures for effective fault isolation and to restore an electrically isolated / faulty seat to the TTL position.

7 Operational Procedures

The crew of the aircraft need to be fully conversant with the operation of the seat. Procedures detailing the means by which the seat's electrical system can be shut down and/or electrically isolated will need to be provided to the crew.

7.1 Crew Information

Procedures should be established and stated clearly to ensure that the seat can be correctly configured for taxi, take-off and landing; and electrically isolated if a fault develops. The following procedures should be provided as a minimum:

- a) Procedure for normal operation of the seat and restrictions on use, e.g. restrictions depending on phase of flight.
- b) Procedure for abnormal operation of the seat in the event of partial or total loss of electrical power, using manual overrides.

- c) Procedures to remove electrical power from the seat at any time. If electrical control or indication is provided in the flight deck, the Flight Manual will need to be amended. If the control is via cabin switch(es) only, Operations Manual / Cabin Crew operating procedures should include procedures for cockpit-cabin co-ordination.
- d) Where appropriate, oral departure briefings to be given to instruct passengers. Briefings need to be composed to avoid passenger confusion.

7.2 **Passenger Information**

Appropriate instructions regarding operation of the seat and any limitations should be presented in a clear and unambiguous manner. A printed hand-held card or booklet may be made available but essential airworthiness information should be provided in the form of easily readable placards or engravings.

8 Maintenance Provisions

Maintenance checks should be scheduled where in-seat system degradation may be a source of hazard, especially hazards such as explosion, fire, fumes and smoke. The extent of maintenance tasks required will depend on the extent of monitoring built into the system or equipment.

General procedural instructions for in-seat system testing should be provided.

Maintenance procedures will need to be specified and observed. Consideration should be given to inspection of seat wiring harnesses that may be vulnerable to damage induced by passengers and cabin configuration changes, seat equipment checks, fixtures and fittings.

9 Modifications (Electrical) to Approved Seats

9.1 **Modifications (Electrical) as proposed by the Original Design Organisation**

Minor modifications that do not affect previously approved airworthiness data may be accepted without investigation provided they are carried out under the auspices of the seat manufacturer's design approval. They would normally be sanctioned by the issue of a Service Bulletin.

Major modifications need to be approved by an organisation with an appropriate design approval to Part 21 Subpart J.

Any in-seat equipment changes should be assessed and demonstrated to maintain compliance with the applicable airworthiness requirements. For in-seat equipment that is not the responsibility of the seat manufacturer, e.g. IFE equipment, the seat manufacturer will need to demonstrate that the provision made for such in-seat equipment is still applicable to the new equipment. Particular attention should be paid to equipment cooling requirements, in-seat wiring and connector rating etc.

Where seat control functions are integrated into other systems, e.g. IFE, it is the seat manufacturer's responsibility to ensure that any changes to that system do not affect the safe operation of the seat and compliance with the applicable airworthiness requirements is maintained.

9.2 **Modifications (Electrical) as performed by a Design Organisation other than the Original Design Organisation**

Seats that are modified by other approved organisations may invalidate the ETSO seat approval. Such modified seats may be approved for use on an aeroplane under a major modification. However, the modified seats can no longer claim to be ETSO approved. Re-approval (ETSO) of such seats can only be achieved under the auspices of the seat manufacturer's design approval.

For modification to the in-seat equipment that is not the responsibility of the seat manufacturer, e.g. IFE equipment, the seat manufacturer should be consulted to ensure that the provision made for such in-seat equipment is still adequate for the new equipment. If the seat provision can be demonstrated to be applicable to the new equipment, the seat approval may be maintained.

INTENTIONALLY LEFT BLANK

Leaflet 25-40 Maintenance and Inspection of Crew Harnesses and Passenger Seat Belts (Metal to Metal Attachment)

1 Introduction

1.1 The following information may be used to establish a consistent CAA policy appertaining to the maintenance of seat belts and harnesses.

1.2 In the absence of manufacturer's recommendations the following conditions must be satisfied by an operator deciding to adopt the 'on-condition' philosophy in preference to load testing:

- a) A detailed visual inspection including the seat attachments for security of installation and integrity of fittings. Check for signs of distress, wear or biochemical staining at intervals not exceeding 6 months.
- b) Whenever seat belts or harnesses are removed for repair or re-conditioning, the requirements of CAA's Specification No. 1 – Safety Belts – as an example must be observed. (See Attachment.)

The CAA will accept the following values, depicted in the table below, as an acceptable sample of the work completed in respect of the maintenance of safety belts and harnesses:

Requirement	Sample
i) Application of design ultimate load subsequent to repair of seat belt/harness assembly.	1 % of batch or at least one assembly whichever is the greater.
ii) Following the application of the load defined in paragraph (i), the seat belt/harness assembly shall be subjected to the requirement of paragraph 5.4.1 of CAA Specification No. 1 in order to establish the buckle release load which shall not exceed 20 lbf.	

INTENTIONALLY LEFT BLANK

Appendix 1 Safety Belts

1 Introduction

- 1.1 Although this Specification was written originally for aeroplanes, a safety belt designed to this Specification is also acceptable to the CAA for use in a Rotorcraft.

2 Applicability

- 2.1 Safety belts shall comply with this Specification or with such other Specifications as the CAA may approve. Alternative Specifications, submitted for approval, shall provide at least the same amount of protection. FAA TSO C.22(f) is considered to be an acceptable specification provided that compliance with paragraphs 3.8, 4.2, 5.3, 5.4, 5.5 and 5.6 of this Specification is also demonstrated.
- 2.2 FAA TSO-C22g or JTSO-C22g qualified safety belts are considered acceptable for installation with no further consideration of the requirements of this Specification.
- 2.3 The installation of safety belts shall be done in accordance with the certification requirements for the aircraft.

3 Form

- 3.1 The belts shall be individual to a single occupant and shall be suitable in every respect for installation in an aeroplane for the purpose of restraining the wearer, without causing significant injury, against the ultimate inertia forces prescribed.
- 3.2 The correct method of using the belt shall be rapid and obvious.
- 3.3 Parts, made of metal or similar unyielding material, which come into contact with the wearer, shall be well rounded where necessary.
- NOTE:** Consideration should be given to the fact that the wearer does not remain in the normal sitting position during the application of the higher accelerations.
- 3.4 No part of a safety belt shall pass between the wearer's legs or shall appreciably restrict the movement of the wearer's limbs.
- 3.5 The belt shall, when correctly adjusted to the wearer, remain in position irrespective of variation of load.
- 3.6 Those parts of the belt which under the prescribed accelerations restrain, and are in contact with the wearer, shall be not less than 50 mm (2 in.) wide.
- NOTE:** However for belts not needing TSO approval an approved military belt 44 mm (1.75 in) minimum width which is otherwise acceptable will not be rejected by the CAA.
- 3.7 Those parts defined in paragraph 3.6 shall be such that the whole of the minimum width specified is effective in transmitting load from the parts to the wearer.
- 3.8 When correctly installed, the belt, when worn, shall lie across the groin of the wearer. The belt when so worn shall lie in a plane which is approximately at 45° to the plane of the longitudinal and lateral axes of the aeroplane.
- 3.9 Throughout this Specification, a belt is regarded as being divisible into various members (e.g. left strap, right strap, release mechanism, etc.) which are liable to be detached from each other for purposes of storage or replacement. It is further

envisaged that more than one firm may be concerned in the manufacture of the completed belt; for example, a release box may be made by a different firm from that responsible for the webbing parts.

4 Strength

4.1 The certified strength of a belt is determined by the tests of paragraph 7.

NOTES: 1) The certified strength required of each member will depend upon the manner in which the belt is installed in the aeroplane and upon the emergency alighting accelerations appropriate to the particular aeroplane.

2) The emergency alighting accelerations for a particular aeroplane type into which the belt is to be fitted may be determined in consultation with the aeroplane manufacturer. Alternatively the belt may be made sufficiently strong for it to be suitable in any aeroplane type. It is emphasised that greater strength will permit the belt to be certified as being capable of giving greater restraint, and this greater restraint may be of value in crash conditions.

4.2 The strength of belts with self-aligning and fittings, fitted in a normal forward-facing installation, however, may be designed for the loads prescribed in paragraph 4.3. The loads of paragraph 4.3 may not be used and the installation shall be conservatively represented in the tests as required by paragraph 7 if:

a) When restraining an occupant, the vertical projection of the angle between any strap (at its attachment point) and the fore and aft axis of the aircraft exceeds 15° , or, if the end fittings are not self-aligning,

or

b) The installation is not a forward facing seat installation.

4.3 For unit value of forward g the basis of certified strength required of a member is 670 N/g (150 lbf/g), this load shall be multiplied by the prescribed forward g for the aeroplane type. Safety belt attachment fittings shall have an additional strength factor of 1.33.

5 Means of Adjusting, Fastening and Releasing

5.1 The belt adjustment shall be either in the buckle or adjacent to it. The adjustment provided in this way shall be such as to suit all persons likely to use the belt. A separate action shall not be necessary to lock the means of adjustment.

NOTE: The load required to vary the adjustment, i.e. tighten or loosen the belt, should not exceed 134 N (30 lbf) and the design should be such that it is easy to operate.

5.2 The means of fastening and releasing shall be rapid and obvious and shall be of the metal to metal positive latching type. The design shall be such that the possibility of the means of locking, releasing or adjustment being jammed by loose clothing or by twisting of the belt, is extremely remote. The fastening means shall be designed to preclude incorrect latching by the wearer.

NOTE: Instructions may be marked on the belt to facilitate its use. However, the action should not be such as to demand instructions.

5.3 The wearer, shall be able to release the belt with either hand, regardless of aircraft orientation in an otherwise survivable accident without undue difficulty.

- 5.4 The force required to effect release from the belt shall be assessed when, after the belt has been subjected to a load as near as practical to the ultimate load (see paragraph 7.2.2), it is under a residual load of 1112 N (250 lbf).
- 5.4.1 Where a conventional lever operated release mechanism is used (i.e. one which can be grasped with all the fingers of one hand) the load to effect release under the conditions defined in paragraph 5.4 shall not exceed 90 N (20 lbf).
- NOTE:** In addition to the requirements of 5.4.2 it is also recommended that the minimum release load should not be less than 22.5N (5 lbf).
- 5.4.2 To avoid inadvertent release there shall be a free movement of the lever and the belt shall remain fastened until the lever attains an angle of not less than 70° or not more than 95° to its position at rest. The lever shall be spring loaded to the position it normally assumes when the belt is fastened.
- NOTE:** Release at a lever angle of less than 70° may be acceptable where the design is such that it can be demonstrated that the lever is unlikely to be caught and moved by clothing.
- 5.5 Where means of release other than by a conventional lever are employed the functional characteristics and release loads of such means shall be agreed with the CAA.
- 5.6 Where the positive locking action of the buckle is dependent upon a spring element, no single failure shall cause or permit the belt to release, unless an adequate fatigue life has been established.
- NOTES:** 1) A total of 100,000 cycles may be assumed as equal to 10 years of life.
2) It is recommended that the fastening and releasing mechanism should not embody parts which need to be manufactured and maintained to close tolerances for their satisfactory functioning.
- 5.7 The means of fastening shall be such that the responsible crew member will be able to see at a glance whether the belt is securely fastened or not.
- 5.8 Extension pieces shall be identified as to the type of belt with which they are to be used. Extension pieces shall be designed and tested to the same standards as are established for belts submitted in compliance with this Specification.

6 Materials and Processes

This paragraph 6 is applicable only to parts which contribute to strength, and to parts which are functionally important.

- 6.1 Only materials to a suitable approved specification¹, or obtained from a source approved by the CAA, shall be used.
- 6.2 Fittings shall be made of metal or of materials that have been demonstrated to be equally satisfactory for their intended function.
- 6.3 Materials which may deteriorate in service or materials the properties of which may be significantly affected by ambient conditions (e.g. leather) shall not be used.

1. British Standards Specifications issued by the British Standards Institution and D.T.D. Specifications obtainable from HMSO are approved. Other specifications will be approved by the CAA if, in its opinion, materials accepted as complying with these Specifications have the essential properties assumed in the technical investigation associated with the design approval.

- 6.4 Where such processes as soldering, brazing, welding and casting are used, suitable factors and safeguards acceptable to the CAA shall be employed. Primary load carrying castings shall comply with the requirements for critical castings.
- 6.5 The choice of materials and of protective treatments for those parts which cannot readily be inspected shall be such as to minimise the risk of corrosion or deterioration.
- 6.6 Materials shall be flame resistant to the appropriate standard defined in the certification basis of the aircraft.

7 Tests

7.1 General

Each member shall be tested in a manner which is agreed by the CAA to represent adequately the conditions of the installation. Accurate representation may be necessary for cases where unusual geometry or eccentricity of loading could affect the ultimate load or the functioning of the means of release. Tests shall be arranged so that the friction effects in the test apparatus do not significantly relieve the stress in any member under test.

The load in a member shall be taken as the load applied to the end nearest to the point of attachment to the airframe or seat.

7.2 Prototype Belts

- 7.2.1 Each member shall be tested to the ultimate load: the member will be accepted if each part supports the load required of it without significant slipping of any adjusting mechanisms it may include.

NOTE: If, at the point during this test when one half of the certified strength is reached, an inspection is made of those members utilising webbing or similar material in a load-bearing capacity, it may be possible to obtain some confirmation whether or not it will be possible to carry out the production test of 7.3.2.1 without damage to otherwise satisfactory series belts.

- 7.2.1.1 The load to be applied shall be that of paragraph 4.3 multiplied by a factor of 1.2. Where significantly new designs are being tested the CAA may require more than one specimen to be tested.

- 7.2.2 Compliance with the requirements of paragraph 5.4 shall be demonstrated by tests in which the release mechanism is first loaded by means of the members normally assembled to it, to as near as is practical to the ultimate load of the belt (in no case to less than its certified strength). The load shall then be reduced to not less than that prescribed in paragraph 5.4, and the release mechanism operated. The force required to operate it shall be assessed and shall be such that it can be applied without difficulty by a wearer of the belt. This test shall be made for each combination of loads liable to be critical.

7.3 Series Belts

7.3.1 General

Series belts shall be checked for consistency with that of the prototype by means of the tests prescribed in paragraph 7.3.2.

NOTE: These tests may be modified, in consultation with the CAA, having regard to the particular design and to the results of tests made in accordance with paragraph 7.2. Where experience gained with the production of the particular design shows such test to be unnecessary, the CAA may agree to waive the test requirements of paragraphs 7.3.2.1 and 7.3.2.2 provided that an adequate sample of each production batch is tested in accordance with paragraph 7.3.2.3.

7.3.2 **Schedule of Tests**

- 7.3.2.1 Each member, in which webbing or similar material is used in a load-bearing capacity, shall be loaded to not less than one-half of its certified strength. Under these conditions no sign of incipient failure shall be exhibited.
- 7.3.2.2 Each member incorporating a release mechanism shall be loaded to not less than one-half of its certified strength. The load may then be reduced to not less than that appropriate to the item, as prescribed in paragraph 5.4 and the release shall be operated. Under these conditions the effort required for release shall be comparable to that agreed by the CAA, in the light of tests carried out in accordance with paragraph 7.2.2.
- 7.3.2.3 The ultimate strength as prescribed in paragraph 7.2.1.1 shall be verified by tests to destruction on samples taken at random by the manufacturer, the percentage of parts so tested being decided by the manufacturer, subject to any minimum which may be prescribed by the CAA.
- 7.4 **Reconditioned Belts.** Reconditioned belts shall be subjected to tests similar to those prescribed in paragraphs 7.3.2.1 and 7.3.2.2, or, in agreement with the CAA, 7.3.2.3 on a sampling basis.

8 **Compass Safe Distance**

Where magnetic material is used the compass safe distance shall be not greater than 305 mm (12 in.) (i.e. the belt when at a distance of 305 mm (12 in.) from the compass shall not affect the compass readings by more than 1°). (See British Standard G.100 for further details.)

9 **Marking**

Each normally detachable member of a belt certified as complying with this Specification shall be indelibly marked with:

- the manufacturer's approved inspection mark,
- the part number and/or model number,
- the serial or batch number.

INTENTIONALLY LEFT BLANK

Leaflet 25-50 N15F210B Underwater Locating Beacon

- 1 This SMP has been raised to implement the results and recommendations of Dukane, in respect of their N15F210B Underwater Locating Beacon.
- 2 Dukane's ongoing reliability programme has identified a significant age related reduction in the output of beacons that are greater than 12 years of age. The reduced acoustic output will have a detrimental effect on being able to locate the beacon and its associated flight recorder.
- 3 **Action to be Taken**

Underwater Locating Beacon:	N15F210B
Serial Nos 1 through 14500	Remove from service at the time of their next battery change.
Any one or two letters before the Serial No.	Manufactured after 1978 and are not immediately affected.
Serial Nos 14500 thro C5500 to include all Serial Nos with 5 digits and Serial Nos with one letter plus 4 digits.	Receive one more battery change and then be removed from service at the following battery change.
- 4 The N15F210B beacon, when removed from service can be returned to Dukane for refurbishment and recertification.
- 5 A new DK100 beacon can be purchased from Dukane to replace each N15F210B beacon removed from service.
- 6 Exclusions – Attached are two Appendices listing N15F210B Beacons by Serial Numbers which were built prior to 1979 and from 1979 to 1983 which have since been refurbished with the new potting material and are, therefore, not affected.

Refurbished N15F210B Beacons – Prior to 1979

715	1304	2314	4086	6805	13266
717	1322	2334	4118	6983	13268
738	1343	2418	4168	7005	13280
804	1375	2488	4175	7073	13402
805	1401	2563	4187	7109	13509
844	1446	2566	4283	7130	13535
846	1496	2617	4292	7138	13559
847	1515	2626	4372	7158	13578
849	1526	2653	4373	7176	13582
858	1534	2747	4418	7347	13706
861	1566	2770	4423	7354	13718
878	1587	2873	4447	7357	13900
879	1595	2882	4453	7395	13932
887	1602	2908	4475	7821	14098
888	1607	2939	4640	8186	14448
892	1615	2957	4729	6174	14450
893	1620	2991	4759	8441	
896	1627	3044	4787	8842	
906	1634	3071	4813	9088	
909	1698	3085	4629	10267	
912	1703	3066	4877	10442	
931	1730	3121	4885	10884	
943	1754	3125	4896	10947	
960	1771	3140	4910	10950	
975	1779	3158	4973	10985	
1005	1780	3169	5019	11096	
1041	1807	3176	5029	11097	
1043	1810	3185	5125	11130	
1045	1816	3334	5147	11326	
1082	1835	3367	5157	11343	
1084	1861	3386	5277	11398	
1086	1877	3390	5352	11421	
1112	1878	3466	5449	11425	
1135	1880	3522	5513	11433	
1156	1888	3546	5594	11472	
1169	1889	3557	5607	11473	
1177	1893	3560	5610	11705	
1187	1806	3570	5624	11707	
1191	1910	3667	5811	11786	
1210	1913	3727	5815	12177	
1217	1926	3797	5849	12396	
1223	1940	3806	6002	12423	
1246	1944	3824	6064	12657	
1249	1949	3840	6068	12763	
1255	1954	3845	6402	12784	
1257	1959	3647	6406	12892	
1265	2060	3874	6506	12901	
1278	2176	3893	6600	13112	
1284	2179	3910	6655	13128	
1297	2203	3935	6691	13170	
1302	2261	4006	6756	13258	

Refurbished N15F210B Beacons – from 1979 to 1983

14721	22925	B9224	C5368
14926	22985	B9277	
14998	23006	B9279	
15002	23089	B9265	
15019	23289	B9266	
15204	23416	B9325	
15249	23474	B9381	
15337	23520	B9508	
15651	23550	B9512	
15719	23576	B9812	
15754	23720	C0040	
15923	23989	C0080	
15930	24023	C0089	
16073	24095	C0120	
16226	24111	C0168	
16231	24113	C0183	
16356	24226	C0315	
16448	24277	C1150	
16662	24374	C1401	
16763	24520	C1738	
17065	24618	C1786	
17280	24754	C1874	
17376	24914	C1910	
17734	25005	C1916	
17856	25044	C1923	
17863	B5670	C2281	
18468	B5673	C2375	
18506	B5834	C2393	
18613	B7023	C2394	
18614	B7048	C2395	
18958	B7385	C3311	
19008	B7739	C3373	
19027	B7783	C3410	
19068	B8077	C3499	
19135	B8102	C3562	
19354	B8169	C3593	
19452	B8311	C3597	
19480	B8367	C3604	
19654	B8401	C3612	
20113	B8402	C3616	
20550	B8525	C3904	
20742	B8623	C4046	
20869	B8626	C4060	
20980	B8948	C4109	
21044	B9034	C4502	
21371	B9051	C4564	
21618	B9060	C4658	
21682	B9061	C5168	
22091	B9077	C5201	
22198	B9100	C5212	
22277	B9100	C5362	

INTENTIONALLY LEFT BLANK

Leaflet 25-60 Guidance on Testing Emergency Locator Transmitters (ELTs)

1 Introduction

- 1.1 This Leaflet provides general guidance material to aircraft maintenance organisations, maintenance personnel and operators relating to the procedures to be used for the operational and performance testing of Emergency Locator Transmitters (ELTs). It includes information on ELT system characteristics and the precautions to be considered when testing ELTs to prevent unnecessary deployment of emergency rescue services.
- 1.2 This Leaflet replaces the guidance formerly issued within Airworthiness Information Leaflet AIL/0193.

2 General

- 2.1 The carriage of ELTs is required by ICAO, as detailed in ICAO Annex 6, 'Operation of Aircraft'. For UK operators these requirements are implemented by JAR OPS 1, JAR OPS 3 or the Air Navigation Order (ANO), as applicable.
- 2.2 Testing of ELTs is necessary to provide assurance of their proper operation, installation and continued airworthiness. However, this testing must be conducted in a manner that precludes any degradation in the ability to identify and react to real distress alerts and minimises occurrences of false alerts.

3 System Description and Operation

- 3.1 At present, ELTs are required (by ICAO) to transmit at both 121.5 MHz and on an assigned channel in the 406.0 to 406.1 MHz band. Some ELTs will also transmit at 243 MHz.
- 3.2 The operation of ELTs and of the COSPAS-SARSAT system is described in Appendix 1 to this Leaflet.

NOTE: COSPAS-SARSAT is an acronym for **CO**smicheskaya **S**istyema **P**oiska **A**varynykh **S**udov (Russian, meaning space system for the search of vessels in distress) **S**earch **A**nd **R**escue **S**atellite **A**ided **T**racking.

4 Testing Objectives and Considerations

- 4.1 The objectives of ELT testing are to determine:
- the serviceability of the ELT battery;
 - the serviceability of the 121.5, 243 and 406 MHz ELT transmitters;
 - the integrity of antenna connections and cabling (integral to the ELT and any airframe fuselage-mounted);
 - the proper interface with the sources of encoded data (ELT identification and navigation data); and
 - the radio frequency performance characteristics of the transmitters.

- 4.2 ELT testing must not degrade the system's capability to identify and respond to real emergency situations and should minimise the likelihood of a false alert being generated.
- 4.3 Testing requirements can be categorised as operational and performance. Operational testing, typically once per month, is conducted to establish confidence that the ELT will perform its intended function. Performance testing is conducted less frequently, typically on installation and once every one or two years – on a periodic basis according to the aircraft's approved maintenance programme and in accordance with the ELT manufacturer's guidance, to ensure that the ELT remains within the prescribed performance requirements.

4.4 **Operational Testing**

WARNING: LIVE TESTING IS NOT PERMITTED.

Caution: All transmissions not recognised by the system as a self-test transmission will result in Mission Control Centres (MCCs) being advised of an alert.

- 4.4.1 Some published guidance material suggests that live testing within five minutes of the hour is allowable and/or suggests that self-testing (even with the functionality described in paragraph 4.4.2) is only allowable within five minutes of the hour. Live testing of the 406 MHz transmission is not permitted at any time but there is no restriction on performing the self-test transmission. However, the 121.5 MHz test transmission is not formatted or modulated so as to be identified as a test transmission. It is only recognised as a test by its short duration. Accepted practice is however to conduct any 121.5 MHz test transmission during the period within five minutes of the hour.
- 4.4.2 Not all ELTs have a self-test facility, although all 406 MHz ELTs will have this function. Not all ELTs with a self-test facility will transmit during test. However, ELTs that do transmit during self-test should comply with EUROCAE ED-62 (or equivalent) in that the test transmission at all frequencies will be only for a maximum duration of five seconds, and the 406 MHz transmission will be a single burst that has a specific digital frame synchronisation that is recognised by the COSPAS-SARSAT system as being a test message, and will therefore not be processed as a real alert. Before conducting any self-test it is advised that the ELT's available functionality is first checked against the manufacturer's data.
- 4.4.3 Care must be taken to initiate the ELT self-test only as prescribed by the ELT manufacturer as there may not be a control switch position explicitly identified as 'TEST'. The test sequence may in some cases be initiated by a specific timing and sequence of the 'ON' and 'OFF' controls.

Transmissions must only be made in the self-test mode.

- 4.4.4 The self-test transmission described in paragraph 4.4.2 will satisfy the objectives set out in paragraph 4.1 a) and b). Typically, the ELT and/or control panel will have a light or series of lights which may be accompanied by an aural alert that will indicate proper functionality of the transmitters.
- The radio frequency (RF) characteristics and any encoded content transmitted during the self-test can be verified using dedicated beacon test equipment – see paragraph 4.5.
- 4.4.5 The operational assurance of the integrity of the antenna connection and that the ELT successfully transmits may be achieved by tuning VHF communications receiving equipment to 121.5 MHz. Up to three audio sweeps will be heard during the self-test

(see paragraph 4.4.1). It should also be confirmed that the transmissions ceased within five seconds. However, transmissions will typically be of much shorter duration (< 0.5 seconds). It is possible to use the communications equipment onboard the same aircraft as the ELT to do a coarse confidence check. However, it is likely that even very low power transmissions will be detected at this proximity so where possible, remote receiving equipment should be used.

4.4.6 Some manufacturers recommend a procedure that uses a portable commercial broadcast radio receiver to satisfy the intent of paragraph 4.4.5. In the US, the FAA has issued Action Notice A8150.3 describing this procedure.

4.4.7 The ELT manufacturer will have determined an operational life for the installed ELT battery which would provide for the required endurance of the transmitters in an emergency and allow for any recommended testing. Any testing in excess of the ELT manufacturer's recommendations will have a detrimental effect on the battery's capability to fulfil its function in an emergency. Consideration must therefore be given to the likely cumulative effect of any operational testing on the battery's operational life.

4.5 **Performance Testing**

4.5.1 Performance testing and any live testing may only be carried out in a suitable RF-shielded environment. Shielded bags and boxes with a provision to also incorporate the test equipment, or feeders to it, are available for this purpose. Alternatively, the ELT should be returned to an appropriately approved and equipped repair facility.

4.5.2 Performance testing will typically include:

- a) 121.5 MHz Output Power*;
- b) 121.5 MHz Frequency;
- c) 121.5 MHz Audio Modulation;
- d) 406 MHz Output Power* and consistency during entire data burst;
- e) 406 MHz (channel) Frequency;
- f) Verification of 406 MHz Digital Message (e.g. identification, position);
- g) 243 MHz Output Power* (if applicable);
- h) 243 MHz Frequency (if applicable);
- i) 243 MHz Audio Modulation (if applicable);
- j) Verification of G-switch activation;
- k) Battery recharging or replacement;
- l) Checking for corrosion or other contamination of the interior circuit boards and battery.

*Most ELTs have a detachable antenna allowing a 50Ω interface to connect suitable test equipment. In the event that the ELT does not have a detachable antenna, refer to the ELT manufacturer's suggested method for measuring output power.

INTENTIONALLY LEFT BLANK

Appendix 1 System Description and Operation

- 1 JAR OPS and the ANO require that ELTs are approved. In Europe, ELTs may be approved against ETSO-2C91a (for 121.5 and 243 MHz) and ETSO-2C126 (for 406 MHz). ETSO-approved ELTs will have been shown to have met the minimum operational performance specifications detailed in EUROCAE ED-62. The ELT electrical/RF performance and system interoperability requirements within ED-62 are common to the COSPAS-SARSAT specification for 406 MHz distress beacons, C/S T.001. ELTs used in aviation are approved separately by both EASA and COSPAS-SARSAT.
NOTE: Aviation equipment approvals issued prior to September 2003 for 121.5/406 MHz ELTs to JTSA and/or other EU national aviation authority standards remain valid.
- 2 When activated in an emergency, the 121.5/406 MHz ELT will transmit the following signals:
 - a) A 121.5 MHz, and optionally, a 243 MHz carrier transmitted continuously (or cycled) at approximately 0.1 watts, modulated by a repetitive analogue audio frequency sweep. Some ELTs *may* also modulate the signal to include voice or Morse identification, although this is not common.
 - b) A 406 MHz carrier with pulsed transmissions at approximately 5 watts digitally encoded with unique identifying data (*either* the ELT unique serial number, aircraft tail number, 24-bit address or other operator designated unique number). Later ELTs may also encode the signal with positional data from either an embedded Global Positioning System (GPS) or aircraft navigation system.
- 3 The transmissions are detected and processed by the COSPAS-SARSAT system. There are complementary constellations of geostationary (GEOSAR) and low-altitude earth-orbiting (LEOSAR) satellites accommodating the signal processing and/or relay equipment.

The GEOSAR satellites provide continuous near-global coverage to 70 degrees latitude, North and South.

The LEOSAR satellites are polar-orbiting and provide a complete, but not continuous, global coverage (depending on signal type).
- 4 Ground receiving or tracking stations, known as Local User Terminals (LUTs), process the signals relayed to them by the satellites and route the ELT location and identification data to the Mission Control Centres (MCCs). The MCCs then forward relevant data to the Search and Rescue services.
- 5 The 121.5/243 MHz transmissions are received by the LEOSAR satellites and relayed to LEOLUTs for processing. As the 121.5/243 MHz ELT transmissions contain no encoded positional information, ELT location is computed using doppler techniques. The 121.5/243 MHz transmission characteristics do not permit satellite on-board processing of the signal, so the ELT and LEOLUT must be within the field of view of the satellite simultaneously. This effectively provides coverage within an approximate 3000 km radius of each LEOLUT and does not provide complete global coverage. From only a single satellite pass, two mirror-image potential location solutions are computed. To resolve this ambiguity in the doppler processing technique, a second satellite pass is normally required. GEOSAR satellites do not monitor 121.5 or 243 MHz transmissions.

This process cannot always distinguish between ELT and other 121.5 MHz transmissions which results in a large number of false alerts.

NOTE: Due to the limitations of the 121.5/243 MHz system, COSPAS-SARSAT plans to phase out the 121.5/243 MHz satellite processing service from 1 February 2009.

- 6 The 406 MHz signals are received by both the LEOSAR and GEOSAR satellites.

The LEOSAR satellites provide a 'Local Mode' of operation which is similar to the 121.5 MHz operation described above but with enhanced doppler accuracy due to the improved frequency stability of the 406 MHz transmitters. Location data may also be recovered from the digitally encoded information in the ELT signal. Signal processing is achieved onboard the satellites.

The LEOSAR satellites also provide a 'Global Mode' of operation. The processed ELT data is stored and time-stamped onboard the satellite and re-transmitted so that it can be transferred to each LEOLUT in turn when they come within the footprint of the satellite.

As the GEOSAR satellites are, by definition, stationary relative to the Earth, the doppler technique cannot be used so determination of ELT location is dependant on the digitally encoded data, available either from the embedded GPS receiver or from an external source.

- 7 A fuller description of the system operation is available from the COSPAS-SARSAT website at www.cospas-sarsat.org.

- 8 The system processing for 243 MHz transmissions is basically as described for 121.5 MHz, but 243 MHz transmissions are only detected and relayed by SARSAT LEOSAR satellites. 243 MHz was originally intended for NATO military beacons, but civilian users can now have mixed 121.5/243 MHz beacons. Beacons incorporating 243 MHz transmitters usually also have 121.5 MHz transmitters.

Leaflet 25-70 Portable Battery Powered Megaphones

1 Purpose

The purpose of this Leaflet is to provide guidance in the form of a specification to an operator who has to install portable megaphones in order to comply with the Air Navigation Order.

2 References

Air Navigation Order
CS 25:1327 Plus AMC

3 Introduction

The Air Navigation Order has been amended to require that all UK registered aircraft used for the purpose of Public Transport, having a seating capacity for 60 or more passengers will be required to carry a complement of Portable Battery-Powered Megaphones for use by the crew should an emergency arise.

This Leaflet presents an acceptable means of compliance with the ANO, in the form of a specification which states minimum characteristics and other necessary features and additionally covers associated installational aspects.

It is intended after gaining experience of its application to embody the material into a CAA specification. This specification is intended for guidance to an Operator who may wish to install a commercially available megaphone. Appendices to the specification state recommendations on methods of meeting the specification requirements.

The Federal Aviation Regulations also prescribe in FAR Part 121.309(f) the carriage of portable battery-powered megaphones, but no Specification similar to that proposed by this Paper has been issued by the FAA.

INTENTIONALLY LEFT BLANK

Appendix A

1 Specification for Portable Battery-Powered Megaphones

Intended for use in emergency conditions in Civil Transport Aircraft.

2 Basic Requirements

Portable megaphones to comply with this Specification should have the following characteristics:

a) **Intelligibility**

Under normal ground conditions in the cabin, messages spoken into the megaphone should be intelligible to at least 90% of the occupants in the passenger cabin in the aircraft in which it is expected to operate. See paragraph m) and Annex 1.

b) **Acoustic Power**

As a criterion it can be taken that when the megaphone is used in open country where a reasonably quiet sound background exists it should be capable of providing intelligible speech at a distance of 100 metres. See Annex 1.

c) **Power Supply**

They should have a self-contained power supply. This should not be interpreted to exclude connection, when not in use, to the aircraft power supply system.

d) **Design Standard**

The design of the megaphone and its power supply arrangements should be such that the likelihood of satisfactory operation when needed is high.

e) **Environmental Resistance**

The megaphone should be shown to be suitable for withstanding the environmental conditions which it will experience in the aircraft. It should be so installed as to minimise any adverse effects from the environment.

f) **Mounting in Aircraft**

It should be so installed and retained that it will withstand the emergency accelerations specified in British Civil Airworthiness Requirements Chapter D3-8 paragraph 2 without breaking loose or having its performance impaired.

g) **Compass Interference**

Should powerful magnets be incorporated in the device, it must be so installed that it does not cause a deviation of any compass in the aircraft beyond the limit of one or two degrees (as per CS 25:1327 and associated AMC material).

h) **Acoustic Operational Characteristics**

The microphone should be such as to render the system satisfactorily resistant to the risk of feedback howl. The microphone should also be not unduly critical regarding the distance between it and the mouth of the person speaking. Consideration should be given to making this appropriate distance neutral and self-evident to the user.

i) **Controls**

The number of controls should be minimal, of a type which are self-evident and are easily operable by a crew member even under conditions of stress. The control of volume by the user of the megaphone should preferably be by switch setting although continuous control could be considered. Two levels should be incorporated which can be pre-set on checking a particular installation, one for use inside and one for use outside the aircraft.

j) **General Design**

The megaphone should be so designed that inadvertent operation is unlikely.

k) **Portability**

A suitable means of carrying (such as a harness) should be provided.

l) **Battery Checking**

Arrangements should be made in the maintenance schedule for the checking of the battery. Labels should be attached to the exterior to render battery replacement times easily identifiable.

m) **Tests**

It is necessary to test the megaphone for intelligibility. This should preferably be done in the environments in which it is intended to be used. An alternative test is indicated in Annex 1.

n) **User Instructions**

The megaphone should incorporate simple but effective instructions for its use, on its outside. These should cover switching on and off, volume control and proper use of the microphone.

Annex 1

1 Test for Intelligibility and Acoustic Power

The acoustic conditions in aircraft interiors vary considerably and according to the aircraft design, the number of passengers who may be expected to hear a particular message will vary in accordance with the internal arrangements of the aircraft and the corresponding crew training.

Ideally each type of megaphone should be tested in the cabin environment in which it is liable to be used. Volunteers should be used to simulate the passenger complement. A number of messages should be broadcast containing occasional unexpected words and the volunteers invited to write them down. A 90% correct recording would be regarded as acceptable.

However, it is recognized that the assembly of people required for such a test is expensive and may only be warranted when there are special unknowns. Experiments have shown that there is a reasonable correlation between the performance of a megaphone in the highly absorbent acoustic environment of an aircraft and its ability to be heard at a distance in a quiet open-air environment. It has been established that the megaphones found satisfactory in typical aircraft cabins were all capable of good intelligibility at ranges of 100 metres in the open air.

The open-air test should be conducted in an area where the acoustic environment is reasonably quiet. If it were felt that 'reasonably quiet' is in need of a more formal definition the suggested level would be that the ambient noise should not be greater than 40 dBA. Not less than three observers, spaced apart but all at 100 metres distance from the megaphone should be asked to record appropriate messages. It might well be desirable to use more than one speaker to eliminate the effects of exceptional voice characteristics or lack of training in microphone usage. Again a 90% correct recording would be acceptable having regard to the redundancy provided in a situation by the natural repetition tendency of a speaker in a crisis – particularly if trained to do so.

2 Proof of Suitable Environmental Resistance

Since the portable megaphone does not function continuously, the cost of testing in a simulated environment is considered unwarranted. On completion of a satisfactory intelligibility test, the equipment should be installed in the aircraft with its proper retaining arrangements and then checked for functioning at appropriate intervals (e.g. three months). Completion of a year's flying with proper functioning at three-monthly intervals would be regarded as suitable confirmation that the chosen megaphone was resistant to the effects of temperature, vibration and humidity encountered on that installation. However, extension of overhaul periods would depend on the trust that can be placed on the battery.

3 The Battery

It could well be that the megaphone would be most satisfactory if it incorporated rechargeable cells in its battery. These could be trickle-charged from a detachable lead connected to the aircraft supply. From what is known, successive checks might easily establish an effective time between overhauls of several years of such a combination.

However, most of the readily available specimens incorporate simple batteries containing zinc-carbon or similar dry-cells. These have the great advantage of cheapness and so there is little discouragement of frequent replacement. It is felt essential that only cells date-coded by the manufacturer should be used. The battery should then be tested under load at three-monthly periods. Such tests will enable the build up of useful experience and a realistic replacement time to be deduced. Account should be taken of the temperature conditions in which the aircraft operates. It is particularly important to examine the battery and casing, and the connectors, for corrosion. On an aircraft with good control of the cabin air-conditioning system, a reasonable replacement time of six months, or even a year, might be established. It may well be that shorter periods will be necessary, however.

Experience has shown that the spring type pressure contacts commonly used for batteries comprised of unit cells (e.g. AA or HP7 size) are not satisfactory. This is particularly so with alkaline cells, usually installed to achieve a greater replacement life than the recommended three months limitation for zinc carbon cells. It is recommended that cells should be assembled, preferably by the battery manufacturer, into a proper battery pack which can be incorporated with highly reliable screw-on connectors.

The maintenance organisation of the airline should keep records of the dates of manufacture, installation and testing of the particular cells which they use.

It is possible to obtain more sophisticated primary cells such as the manganese-alkaline or mercury types which could have a longer life. However, whichever cell is chosen, the Airworthiness Division of the CAA finds that there is no substitute for the standard procedure of periodical functional testing. Thus the intervals between tests can only be extended cautiously.

Where longer life type cells are incorporated, even when confidence on the longer life has been established by sample discharge tests, it is useful and conventional to conduct a terminal voltage test on the batteries on interim maintenance. It is pointed out that when fairly high impedance volt meters are used (e.g. AVO) the reading is useless for assessing battery state if the battery is not suitably loaded. Thus while making such a measurement the tester could either operate the megaphone (shouting loudly into it) at the same time, or impose a resistive load so adjusted as to create a current drain of say 300 mA. Cells showing less than 1.1 volts under this condition should be rejected.

Leaflet 25-80 Demonstrating Compliance with CAT.GEN.MPA.140 and ANO Article 119(4A) when Carrying Personnel Locator Beacons

1 Introduction

- 1.1 Following an accident in the North Sea where the deployment and operation of Emergency Locator Transmitters (ELTs) / Personal Locator Beacons (PLBs) was required, the Air Accidents Investigation Branch (AAIB) made a recommendation to the CAA regarding the carriage and use of any radio location devices on Commercial Air Transport (CAT) flights which do not form part of the aircraft's equipment – this is also applicable to Public Transport (PT) flights.
- 1.2 This Leaflet provides helicopter operators with guidance on the general considerations associated with the carriage of personal locator beacons and an acceptable means to demonstrate compliance with Commission Regulation (EU) No 965/2012 (the EASA Air Operations Regulation) CAT.GEN.MPA.140 (Portable Electronic Devices (PED)) and the Air Navigation Order 2016 (ANO) Article 119(4A) (Equipment of PT aircraft).
- 1.3 Locator beacons used for compliance with the provisions of CAT.IDE.H.280 (Emergency locator transmitter (ELT)) and CAT.IDE.H.300 (Life-rafts, survival ELTs and survival equipment on extended overwater flights) must be EASA/CAA approved ELTs and are not covered by this Leaflet. All locator beacons that are carried for other purposes are to be treated as Transmitting Portable Electronic Devices (T-PED) and for clarity are referred to as PLBs in this Leaflet.
- 1.4 Two possible (alternative) means of demonstrating compliance with CAT.GEN.MPA.140 with respect to the carriage of PLBs are described in this Leaflet. Section 4 details how this analysis may be achieved at an equipment level and Section 5 references the alternative processes necessary to achieve the equivalent by conducting tests at an aircraft level.
- 1.5 Annex I of the EASA Air Operations Regulation has the following definitions:
- a. 'Personal locator beacon (PLB)' is an emergency beacon other than an ELT that broadcasts distinctive signals on designated frequencies, is standalone, portable and is manually activated by the survivors
 - b. Transmitting PED (T-PED)' means a portable electronic device (PED) that has intentional radio frequency (RF) transmission capabilities.

2 References

ETSO	European Technical Standard Order.
EUROCAE <u>ED-14F</u>	Environmental Conditions and Test Procedures for Airborne Equipment.
EUROCAE <u>ED-62</u>	Minimum Operational Performance Specification for Aircraft ELTs.
EUROCAE <u>ED-130</u>	Guidance for the use of Portable Electronic Devices (PEDs) on Board Aircraft.
RTCA <u>DO-294C</u>	Guidance on Allowing Transmitting Portable and DO-307 (Cng 1) Electronic Devices (T-PED) on Aircraft.

3 Recommendations

3.1 The following aspects of PLB assessment are key to the safe and effective operation of the equipment:

3.1.1 General Analysis Considerations

It is not necessary for the organisation undertaking the analyses described in this Leaflet to be an EASA Part-21 approved design organisation (DOA).

3.1.2 Data Submission

The helicopter operator should forward the data associated with the completed PLB carriage analysis to the CAA Assigned Flight Operations Inspector. The data should cover all types of PLB that have been assessed for carriage, including those that have been rejected as not being found compatible with the requirements of CAT.GEN.MPA.140. Any data associated with future PLB assessments should also be forwarded to the CAA when completed.

The CAA will keep a record of this data and make the non-company-specific content of it available upon request to other helicopter operators intending to use the same PLB.

3.1.3 Required Reporting Action

If a helicopter operator elects to use a PLB that has been shown to comply with this Leaflet and subsequent incidents of inadvertent activation occur, a Mandatory Occurrence Report (MOR) should be raised.

3.1.4 PLB Production Consistency

Operators should satisfy themselves that PLBs assessed in accordance with this Leaflet are representative of the equipment that the manufacturer will subsequently supply.

PLBs are unapproved items and are therefore not usually available with an EASA Form 1 or equivalent release. In order to provide maximum confidence in the consistency of manufacture to a specific design, they should be procured from reputable sources, such as those holding Part-21 or equivalent approvals for the manufacture of approved aerospace equipment.

In the absence of such approvals, evidence of manufacturing consistency such as certificates of conformity, Product Acceptance Test results etc. should be sought. Possession of an appropriate third-party certification standard, such as AS9100 or an ISO9000 approval, with an appropriate scope, can be used to provide additional confidence.

3.1.5 Shelf Life and Extended Use Considerations

Extended use or storage of a PLB may result in inadvertent activation, failure to activate or erroneous operation.

Helicopter operators should seek the advice of the PLB manufacturers to determine the appropriate shelf life, the maximum carriage life and the appropriate maintenance programme for any PLB that will be carried. This information should be incorporated into the relevant procedures.

The helicopter operator should also monitor PLBs for signs of damage, e.g:

- deterioration of seals;
- cracked casings;
- illegible instruction label;
- damaged switch guards.

PLBs showing signs of damage that may affect their operation or activation shall not be carried.

3.1.6 Use of Approved ELTs as PLBs

If the helicopter operator intends to use an ETSO-approved ELT as a PLB, then some credit may be possible for that existing qualification. The following considerations are then applicable:

- a) ED-62 is an equipment specification only. It does not infer any suitability or approval to fit onto a particular aircraft.
- b) In demonstrating compliance with ED-62, the ELT will have undergone some environmental qualification. However the following should be considered:
 - not all of the environmental qualification tests in ED-14 are required by ED-62, some remain optional;
 - the specified test categories may differ from those in this Leaflet;
 - ED-62 references an earlier version of ED-14 (ED-14C).

A review of the manufacturer's data, such as the Declaration of Design and Performance (DDP) will be required to determine the extent of the declared environmental qualification and a comparison made with those listed in Appendix 1 of this Leaflet.

- c) Manufacturers holding the ETSO authorisation will be approved production organisations. The consistency of manufacture to a controlled design configuration, as discussed in Section 3.1.4 of this Leaflet, can therefore be considered to be assured.

4 Determination of Unlikely Inadvertent PLB Activation

4.1 This Section describes how the helicopter operator can assess the PLB to determine whether it is likely to inadvertently activate. Should a helicopter operator elect to perform the equipment level analysis in accordance with this Section, additional aircraft-level testing as specified in Section 5 will not normally be required.

4.2 However, should a helicopter operator become aware of transmission characteristics associated with inadvertent activation of a PLB that could pose a significant hazard to their aircraft, the helicopter operator should undertake further analysis to determine whether or not the potential threat to airworthiness can be adequately mitigated.

NOTE: Compliance with [CAT.GEN.MPA.140/ANO Article 119\(4A\)](#) cannot be shown for PLBs that have the potential to significantly affect the overall airworthiness of an aircraft.

4.3 In demonstrating that the inadvertent activation of a PLB is unlikely, human factors and environmental factors should be considered.

4.4 Human Factors Aspects

The PLB under assessment should be examined to determine that inadvertent activation is unlikely. For example, there should be no switches that could be operated unintentionally.

4.5 Environmental Test Conditions

Appendix 1 lists the ED-14F environmental test criteria and provides guidance on which categories within them are considered to apply to PLBs carried in large rotorcraft and which are not.

The listed environmental categories may be sufficient to complement an application for a “no hazard, no credit” carriage of these devices on a large rotorcraft and to assist in a demonstration that the PLB is unlikely to be inadvertently activated, nor present a hazard to the rotorcraft whilst in its inactive state.

An environmental qualification checklist has been provided at Appendix 2.

5 Aircraft-Level Testing

- 5.1 In lieu of conducting the analysis at an equipment level, on-aircraft testing representative of transmitting PLBs may be conducted. These tests are performed to demonstrate that, should the PLBs be activated, the aircraft systems will not suffer from adverse interference effects due to the resultant transmission from inside the rotorcraft.
- 5.2 Guidance on testing to demonstrate the aircraft’s tolerance to radio frequency transmissions from inside the aircraft can be found in industry documentation such as EUROCAE ED-130, or RTCA DO-294C and DO-307 (Chg 1).
- 5.3 If the PLB transmits on 121.5 MHz it will also be necessary to show that the requirements of CAT.IDE.H.330(b) (Radio communication equipment) (the ability of the aircraft radio communication equipment to communicate on 121.5 MHz) are still met and not interfered with.

Appendix 1

1 Applicable Environmental Test Conditions

- 1.1 The following ED-14F environmental test categories are considered to be representative of the environment of a large, unpressurised rotorcraft operating offshore. When used as a basis for the environmental qualification of the locator beacon they should provide sufficient assurance that the locator beacon, will neither inadvertently activate nor present a hazard to the rotorcraft whilst in its inactive state.
- 1.2 An alternative test (or set of tests) can be proposed where it can be substantiated that the following categories are not representative of actual rotorcraft operations and that the alternative test is appropriate.
- 1.3 Environmental test regimes other than ED-14F may be used if they can be shown to be equivalent.

Section	Environmental Test	Category	Explanation Of Category
4	Temperature & Altitude	B2	Equipment that is operated in non-pressurised and non-controlled temperature locations on an aircraft that is operated at altitudes up to 25,000 ft (7,620 m).
5	Temperature Variation	B	Equipment that is operated in a non-temperature-controlled or partially temperature controlled internal section of the aircraft.
6	Humidity	C	Equipment that may be required to be operated under conditions such that it is subjected to direct contact with outside air for periods of time in excess of that specified for the standard humidity environment.
7	Operational Shock & Crash Safety	B	Equipment tested for standard operational shock and crash safety.
8	Vibration	U	Equipment to be operated in helicopters with unknown rotor related frequencies. If the vibration environment is known, and the relevant equipment specification requires a service life test, the robust test can be made to represent a service life test by adjusting the test levels and/or the test times using accepted fatigue scaling relationships.
9	Explosive Atmosphere	A Env II	Equipment to be operated in rotorcraft where, in normal operation, the temperature of any surface will neither rise to a level capable of causing ignition, nor will any operating part cause ignition. Environment II is an atmosphere in which flammable mixtures can be expected to occur only as a result of a fault-causing spillage or leakage. Equipment shall meet the standards and test procedures for any one of the explosive atmosphere categories (paragraphs 9.4.1, 9.4.2 or 9.4.3).

10	Waterproofness	S	Equipment operated in locations where it may be subjected to the forces of a heavy stream of fluid such as would be encountered in aircraft de-icing, washing or cleaning operations.
11	Fluid Susceptibility	F	Equipment operated in locations where fluid contamination could be commonly encountered. Testing to cover the relevant fluids identified in Table 11-1 of ED-14F.
12	Sand & Dust	D	Equipment that is operated in locations where it is subjected to blowing dust in the course of normal aircraft operations.
14	Salt Fog	T	Equipment that is operated in locations where it is subjected to a severe salt atmosphere, such as equipment exposed directly to external unfiltered air on hovering aircraft that may operate or be parked near the sea.
15	Magnetic Effect	Z	Compass-safe distance of greater than 0.3 m.
20	RF Susceptibility	T	Test level for equipment with moderate criticality intended to withstand the external RF environment.
21	RF Emissions	M	Equipment that is operated in the passenger cabin where electro-magnetic apertures are significant but not directly in view of radio receiver antennas.
24	Icing	A	Equipment that is operated in locations where it may be subject to the effects of external ice or frost adhering to it.
25	ESD	A	Electronic equipment that is installed, repaired, or operated in an aerospace environment.
26	Fire & Flammability	C	Non-metallic equipment, component parts, sub-assemblies operated in pressurised or non-pressurised zones and non-fire zones with largest dimension greater than 50 mm.

2 Expected Performance under Environmental Test Conditions

- 2.1 The PLB should be subjected to the tests listed above in a non-transmitting state.
- 2.2 The PLB will be considered to have passed these no-hazard, no-credit tests if exposure to the environmental condition defined above does not result in PLB transmission.
- 2.3 Additionally, for tests 15, 20 and 26 the PLB shall have no effect beyond the limits specified in the tests.

3 Non-Applicable Environmental Test Conditions

- 3.1 The following ED-14F environmental condition test sections are not considered relevant to the subject locator beacon when carried on board a large rotorcraft:
- §13 Fungus Resistance.
 - §16 Power Input.

- §17 Voltage Spike.
- §18 Audio Frequency Conducted Susceptibility (Power inputs).
- §19 Induced Signal Susceptibility.
- §22 Lightning Induced Transient Susceptibility.
- §23 Lightning Direct Effects.

4 Removing the Power Supply

- 4.1 Alternative means that prevent inadvertent transmission of these devices such as removing/disabling the power supply may be considered.

INTENTIONALLY LEFT BLANK

Appendix 2 Environmental Qualification Checklist

Section	Environmental Test	Category	Pass/Fail	Test Report Reference
4	Temperature & Altitude	B2		
5	Temperature Variation	B		
6	Humidity	C		
7	Operational Shock & Crash Safety	B		
8	Vibration	U		
9	Explosive Atmosphere	A Env II		
10	Waterproofness	S		
11	Fluid Susceptibility	F		
12	Sand & Dust	D		
14	Salt Fog	T		
15	Magnetic Effect	Z		
20	RF Susceptibility	T		
21	RF Emissions	M		
24	Icing	A		
25	ESD	A		
26	Fire & Flammability	C		

Signature

Company

Position

INTENTIONALLY LEFT BLANK

Leaflet 25-90 Minimum Space for Seated Passengers

NOTE: *This document was previously issued as Airworthiness Notice No. 64, Issue 2, 29 October 2001 and then as Generic Requirement (GR) No. 2 in CAP 747. The regulatory framework has changed since this GR was written and consequently this document does not form part of an EASA approved certification basis, except in the case where the UK certification basis (prior to 28 September 2003) was grandfathered by EASA. Hence, although this GR was previously mandatory, it is now only applicable to those few aircraft that have a certification basis that includes this GR. The latest certification requirements, which supersede this GR, provide the same or improved safety standard. GR No. 2 was removed from CAP 747 in November 2014 as a result of the implementation of Commission Regulation (EU) No. 965/2012 (as amended) and the introduction of Part 26 – Additional Airworthiness Specifications for Operations. It is now reproduced below in its original form for reference purposes only, in order for it to remain available for those relatively few aircraft to which it continues to apply.*

1 Applicability

This Generic Requirement is applicable to all UK registered aeroplanes over 5,700 kg MTWA, operated for the purposes of Commercial Air Transport and configured to carry 20 or more passengers.

2 Introduction

- 2.1 The layout of cabin interiors must be approved under modification approval procedures. As part of that approval each seat type shall be approved as required by CS 25.785 or BCAR Section D, Chapter D4-4 paragraph 2.1.2. The approval procedure for such controlled items is defined in Part 21 Subparts E and K (or in BCAR Sections A or B, Chapter A4-8 or B4-8 where applicable).
 - 2.2 At the initial evaluation of a seat an assessment of the limiting conditions of use is made and, when agreed with the seat manufacturer, these are specified on the General Arrangement drawing, on the Declaration of Design and Performance (DDP) or specifically highlighted in a letter of approval. Included in these limitations is a minimum seat pitch at which approval for installation on an aeroplane has been granted. This minimum pitch is defined taking into account head, trunk and leg strike areas of the seat in front, the ability to occupy the seat and, if necessary, quickly vacate the seat and enter the aisle in an emergency.
 - 2.3 The CAA has been asked to re-assess the use of seats at a pitch less than has generally been requested in the past, particularly with respect to the more modern, high technology seat designs, and yet still to be satisfied that the various general criteria above are being achieved. Of particular concern is
-

the effect that such lower seat pitches can have on the seat occupancy and the ease of egress from these seats.

- 2.4 To formalise the minimum acceptable seating standards the normal design extremes used for certification purposes for all occupied zones, (namely the anthropometric data for the 5th percentile female to the 95th percentile male), have been taken into account. In this regard the critical dimension for the seated occupant is the buttock-knee length. Additionally, affecting the ease with which the occupant can stand up and move from the seat to the main cabin aisle, is the minimum distance and the vertically projected distance between the seat and any seat or fixed structure immediately ahead of the occupant.
- 2.5 Use of these three dimensions as the criteria for the determination of the acceptability of any seating configuration is considered to provide a realistic minimum standard that can be uniformly adopted, whether the seating being considered is placed adjacent to seats of the same or different types, or other typical interior structures. These Requirements are not intended to supersede or replace existing occupant protection criteria prescribed in CS 25.785 or BCAR D4-4.

3 Compliance

- 3.1 With effect from 1 April 1989, all aeroplanes defined in paragraph 1 above and which are being subject to the provision of a new (not previously approved) or amended seating configuration, shall comply with this Generic Requirement.
- 3.2 With effect from 1 January 1992 all aeroplanes defined in paragraph 1 above shall comply with this Generic Requirement.

4 Requirements

- 4.1 The minimum distance between the back support cushion of a seat and the back of the seat or other fixed structure in front, shall be 26 inches. (Figure 1, Dimension A.)
- 4.2 The minimum distance between a seat and the seat or other fixed structure in front, shall be 7 inches. (Figure 1, Dimension B.)
- 4.3 The minimum vertically projected distance between seat rows or between a seat and any fixed structure forward of the seat, shall be 3 inches. (Figure 1, Dimension C.)

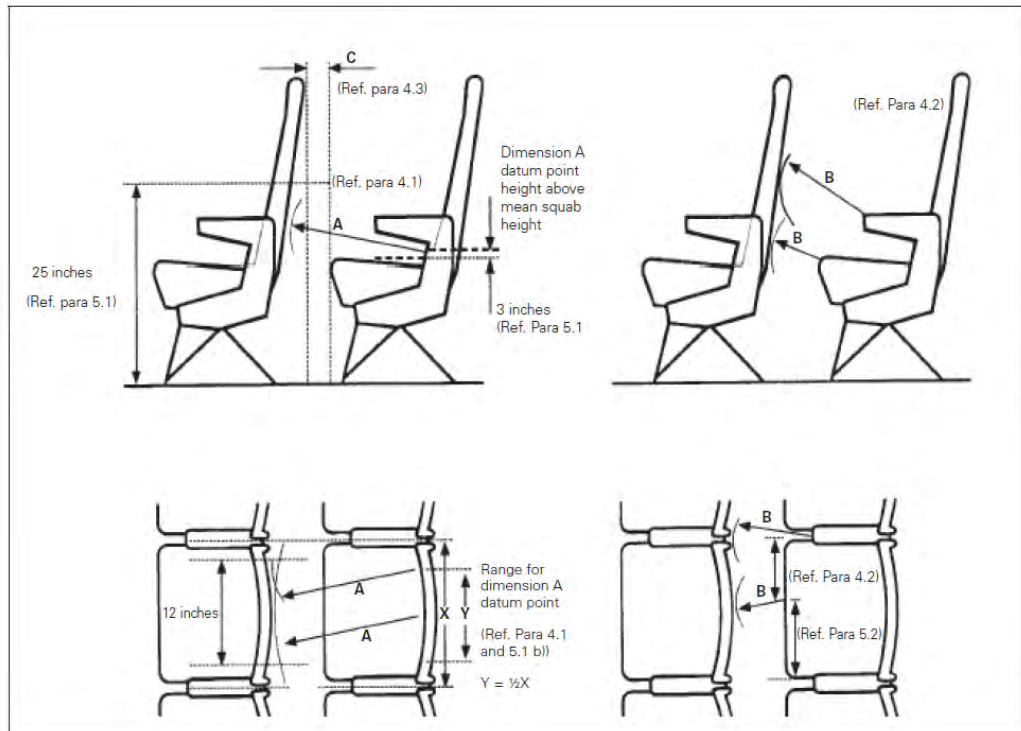

Figure 1 Minimum Dimensions required by paragraphs 4.1, 4.2 and 4.3

5 Additional Information

- 5.1 The measurements required for the demonstration of compliance with the requirement given in paragraph 4.1 above are as follows:
- from a datum point in the centre of the seat back at a height of 3 inches above the mean uncompressed seat squab height to the seat or other fixed structure in front made in both vertical and horizontal arcs up to a limiting height of 25 inches above the carpeted floor level, over the full seat place widthg 'X'. (See Figure 1).
 - from any point on the seat back within the centre one half 'Y' of the seat place width at a height of 3 inches above the mean uncompressed seat squab height to the seat or other fixed structure within the central 12 inch region in front made in vertical and horizontal arcs up to a limiting height of 25 inches above the carpeted floor level.
- 5.2 The full width of the forward edges of the seat squab cushion and the seat armrests shall be used as the datum points for the measurements of the minimum distance required by paragraph 4.2 above. From these points the measurement of the distance shall be made in both horizontal and vertical unlimited arcs.
- 5.3 The vertically projected distance required by paragraph 4.3 above shall be measured between the forward edge of the seat squab cushion or the most

forward extremity of the armrests and the most aft part of the seat or fixed structure in front.

- 5.4 Where a magazine rack is provided for the normal stowage of the cabin safety leaflet, sick bag and in-flight reading material provided by the operator, such normally provided material shall be in place during the measurements. Similarly, any fold down or other type of meal table attached to either seat or fixed structure should be in its normal stowed (take-off and landing) position for all measurements.
- 5.5 All measurements shall be made with the seats in the upright (take-off and landing) position, and the armrests shall be down.
- 5.6 No alleviation to these requirements will be granted on the basis of deformable soft furnishings.
- 5.7 All modifications to seats, their installation or any modification to adjacent fixed structures, necessary to achieve compliance with this Generic Requirement shall be the subject of Part 21 Subpart E procedures, or, for non-EASA aircraft, the appropriate BCAR Section A or Section B major modification procedure, Chapters A2-5/B2-5.

Leaflet 25-100 Access to and Opening of Type III and Type IV Emergency Exits

NOTE: *This document was previously issued as Airworthiness Notice No. 79, Issue 3, 16 March 1989 and then as Generic Requirement (GR) No. 3 in CAP 747. The regulatory framework has changed since this GR was written and consequently this document does not form part of an EASA approved certification basis except in the case where the UK certification basis (prior to 28 September 2003) was grandfathered by EASA. Hence, although this GR was previously mandatory, it is now only applicable to those few aircraft that have a certification basis that includes this GR. The latest certification requirements, which supersede this GR, provide the same or improved safety standard. GR No. 3 was removed from CAP 747 in November 2014 as a result of the implementation of Commission Regulation (EU) No. 965/2012 (as amended) and the introduction of Part 26 - Additional Airworthiness Specifications for Operations. It is now reproduced below in its original form for reference purposes only, in order that it remains available for those relatively few aircraft to which it continues to apply.*

1 **Applicability**

- 1.1 This Generic Requirement is applicable to all UK registered aeroplanes over 5700 kg MTWA, operated for the purposes of Commercial Air Transport and configured to carry 20 or more passengers and equipped with Type III emergency exits and/or Type IV emergency exits or their equivalent. Exits considered to be equivalent to Type IV exits are referred to as Type IV exits in this Requirement.
- 1.2 For the purpose of this Requirement, exits that are smaller in size than Type III emergency exits (including elliptical exits) shall be deemed to be Type IV emergency exits, even though they are not formally classified as such.

2 **Introduction**

- 2.1 From a review of accidents, where rapid evacuation of the aeroplane was a critical factor governing passenger survival, Issue 1 of Airworthiness Notice No. 79 stated that it appeared that mid-cabin Type III emergency exits, although only rated for a relatively small number of passengers, could, in certain circumstances, become a major escape route.
- 2.2 Following further reviews it has been decided to extend the applicability of this Requirement to include Type IV exits (Issue 2) and to specify the requirements for face-to-face seating configurations.
- 2.3 Current Requirements governing the access to Type III and Type IV emergency exits do not quote specific dimensions for the minimum width of

access to such exits between adjacent seat rows. Tests have demonstrated that, with typical economy class seats, seat pitches down to approximately 30 inches have little or no effect on the rate of exit egress. The major constraint on the location of seats relative to such exits is the need to ensure that the seats do not impede the removal and disposal of the exit hatches.

- 2.4 The CAA believes that Type III and Type IV emergency exits need to be made more effective and is seeking international adoption of radical improvements in access to and ease of opening of such exits. Such new regulations, if adopted, will of necessity be on a relatively long timescale. In the interim, the CAA has established that, whilst only small improvements can be made in exit egress rates, immediate action can be taken that will provide greater space adjacent to the exit and thereby facilitate the more rapid opening of such exits and reduce the time taken for the initiation of passenger egress. Accordingly, this Requirement has been issued to ensure effective opening, handling and disposal of the hatch and to define the additional minimum access requirements for Type III and Type IV emergency exits.
- 2.5 To realise the full potential of improved exit access, it is also essential that passengers seated adjacent to the exits are readily able to determine the correct method of opening and disposal of exits in an emergency. Whilst such information is provided in the Cabin Safety Leaflet, operating instructions, comparable to those contained in such Leaflets, are required by this Requirement to be repeated on the backs of all seats on the seat row immediately forward of the exits, except as referred to in paragraph 5.6.
- 2.6 To encourage a smooth passenger flow through the relatively small Type III and Type IV emergency exits, it is important that passengers are encouraged to approach the exit from the cabin aisle via an access route that is sensibly normal to the exit. Alternative routes such as can be created by climbing over seat backs which have been pushed forward should be discouraged. To achieve, where possible, an orderly approach to the exit from the aisle, the CAA has decided that the seat backs of those seat rows immediately forward and aft of the exit access route from the aisle shall be restricted in both recline and break forward not only to maintain the minimum access width but also to maintain the seat back in an essentially upright attitude.
- 2.7 Whilst the revised seating arrangements required by this Requirement should minimise the likelihood of passengers either kneeling or standing on seats to reach the exit, it is nevertheless considered necessary to ensure that the seat design is such that a person's foot, say, may not become trapped.

3 Compliance

- 3.1 With effect from 1 July 1986 all aeroplanes defined in paragraph 1 above with Type III emergency exits, having all forward facing or all aft facing seats adjacent to these exits, shall comply with this Generic Requirement.

- 3.2 With effect from 1 December 1987 all aeroplanes defined in paragraph 1 above with Type IV emergency exits, having all forward facing or all aft facing seats adjacent to these exits, shall comply with this Generic Requirement.
- 3.3 With effect from 1 April 1989, all aeroplanes defined in paragraph 1 above that are subject to the provision of a new or amended seating configuration, shall comply with this Generic Requirement. In addition, with effect from 1 May 1989 all aeroplanes defined in paragraph 1 above having face-to-face seats forming the access route to these exits shall comply with this Generic Requirement.

4 Requirements

- 4.1 To facilitate rapid opening and disposal, each Type III and Type IV emergency exit, in addition to meeting the current requirements of CS 25.813(c) (1) or BCAR Section D, Chapter D4-3, paragraph 4.2.5(d) as applicable, shall have access space meeting the requirements specified in either paragraph 4.1.1 or 4.1.2 for Type III exits or either paragraph 4.1.3 or 4.1.4 for Type IV exits where conventional seating arrangements are installed, and in addition paragraph 4.1.5 when face-to-face seating is installed.

- 4.1.1 Where all forward facing or all aft facing seats are arranged such that there is a single access route between seat rows from the aisle to a Type III exit, the access shall be of sufficient width and be located fore and aft so that no part of any seat which is beneath the exit extends beyond the exit centre line and the access width between seat rows vertically projected, shall not be less than half the exit hatch width including any trim, or 10 inches, whichever is the greater (see Figure 1).

NOTE: The outboard armrest must not protrude across the exit aperture nor impede the removal of the exit hatch.

- 4.1.2 Seats may only be located beyond the centre line of a Type III exit provided there is a space immediately adjacent to the exit which projects inboard from the exit a distance no less than the width of a passenger seat and the seats are so arranged as to provide two access routes between seat rows from the cabin aisle to the exit.

NOTE: Where more than one access route from the cabin aisle to a Type III exit is provided, the minimum access width referred to in paragraph 4.1.1 need not apply (see paragraph 5.4 of this Requirement).

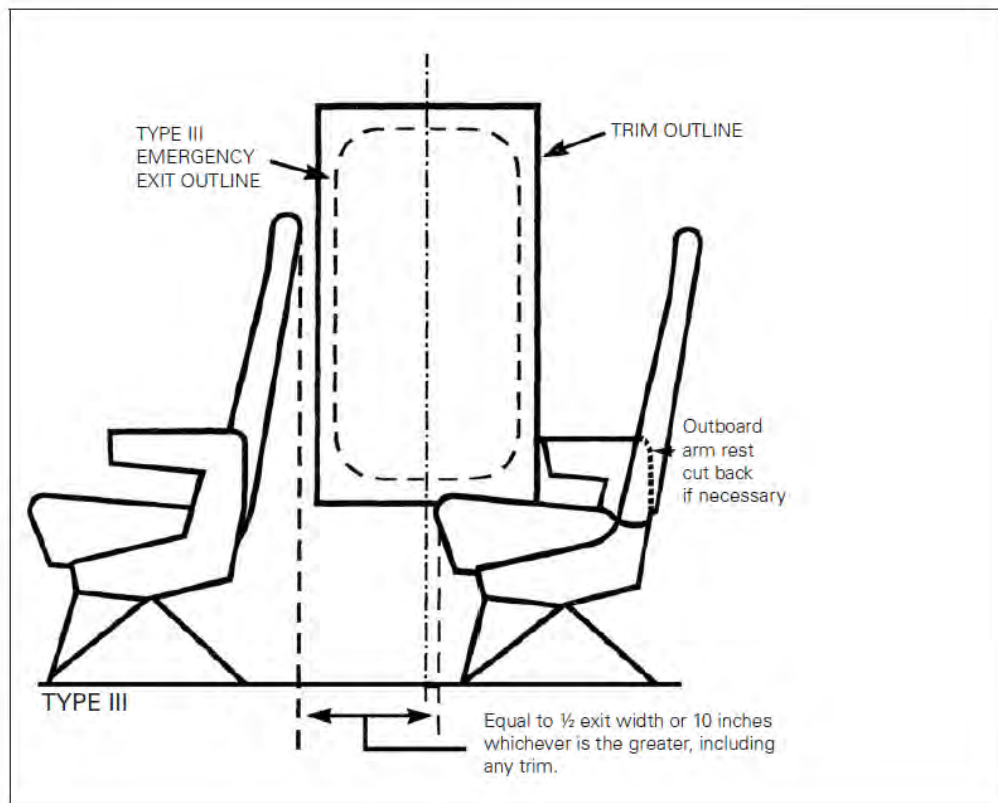

Figure 1 Minimum Dimensions required by paragraphs 4.1, 4.2 and 4.3

4.1.3 Where all forward facing or all aft facing seats are arranged such that there is a single access route from the aisle to a Type IV emergency exit, then the projected exit aperture shall not be obstructed from the exit to the aisle (see Figure 2 and paragraph 5.4 of this Requirement).

NOTES

- 1 Some incursion into the projection area of the emergency exit hatch, including its trim, may be acceptable so long as it can be shown that the incursion does not impair the rapid removal of the exit hatch.
- 2 The outboard armrest must not protrude across the exit aperture nor impede the removal of the exit hatch.

4.1.4 Seats may only be located in line with a Type IV exit such that the seat back is within the projected exit aperture provided there is a space immediately adjacent to the exit. Such a space shall project inboard from the exit a distance no less than the width of a passenger seat and be so arranged as to provide two access routes between seat rows from the cabin aisle to the exit. (See paragraph 5.4 of this Requirement.)

4.1.5 Where face-to-face seating is provided adjacent to the emergency exit, the minimum permitted distance between any parts of the seat rows shall be 16 inches vertically projected and the minimum permitted distance between the plane of the seat backs on either side of the access route shall be 52 inches

measured on the mid-lines of each seat place at a height of 3 inches above the seat cushions. (See Figure 3 and paragraph 5.6 of this Requirement.)

- 4.2 Instruction Placards, clearly indicating the method of opening and disposal of each Type III and Type IV emergency exit (additional to existing opening instructions at the exit), shall be located in a prominent position and clearly visible to the occupant of each seat which forms the access route from the cabin aisle to the exit (see paragraphs 5.6 and 5.9 of this Requirement).

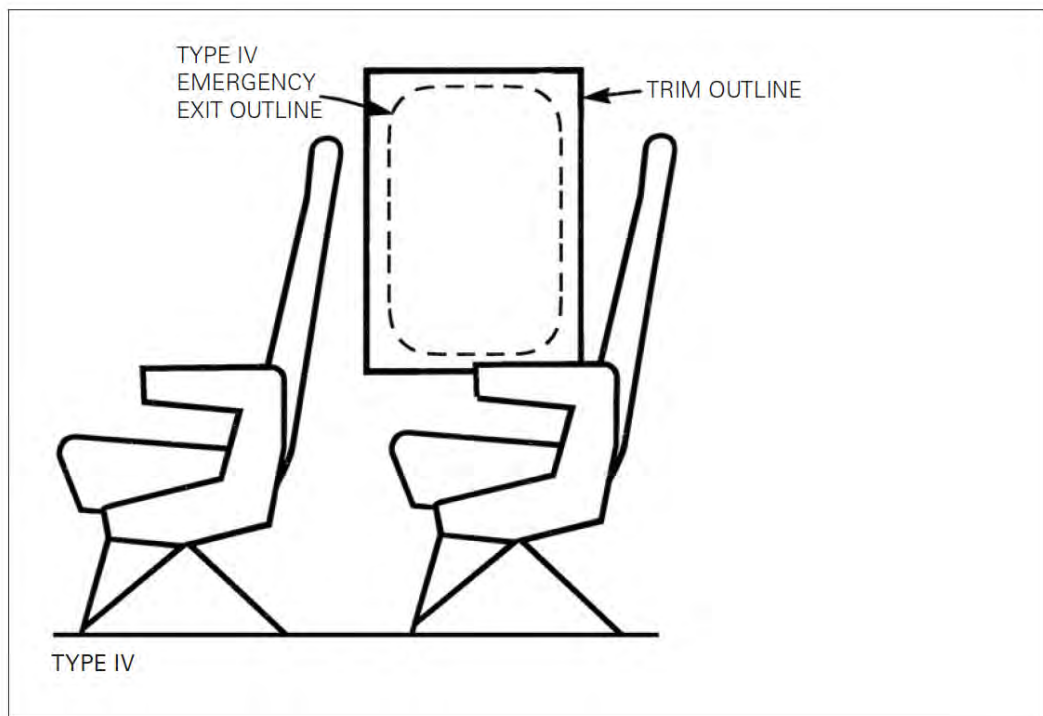

Figure 2 Minimum Access Required by Paragraph 4.1.3

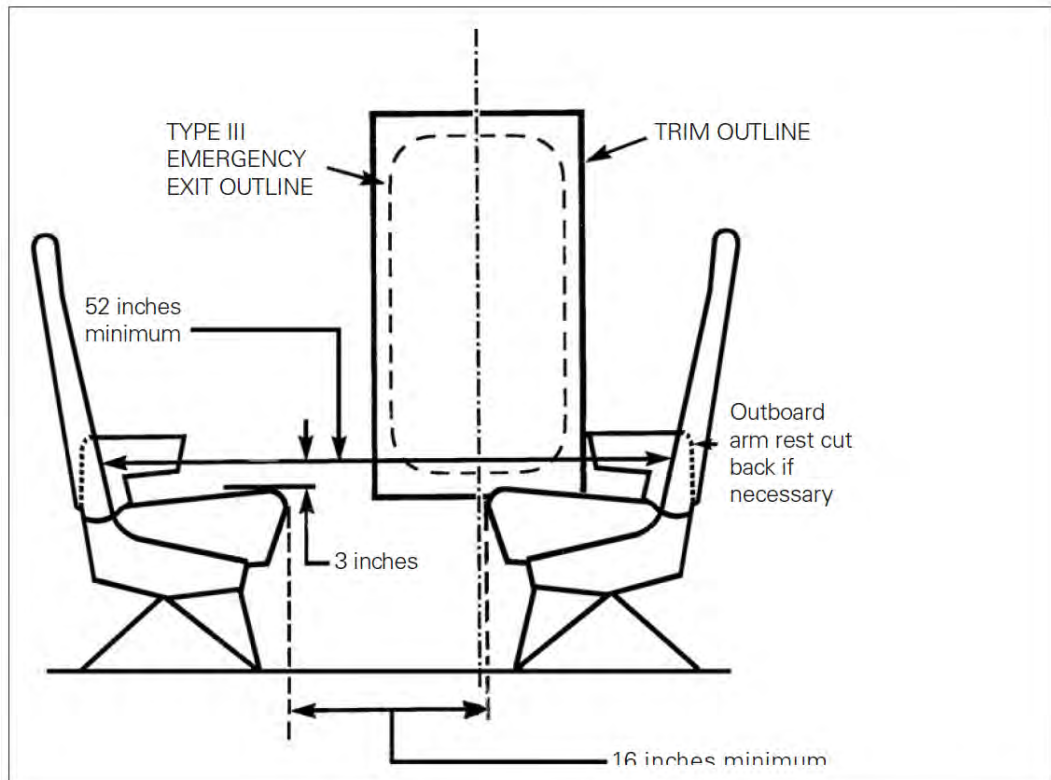

Figure 3 Minimum Access Required by Paragraph 4.1.5

- 4.3 The seat back of each seat which forms the boundary of the access route to each Type III and Type IV emergency exit shall be restricted in its movement (break forward and recline, where fitted) so as to maintain the minimum access to the exit required by paragraph 4.1, and ensure that the seat back is in an essentially upright position, without overlapping the projected opening of the exit.
- 4.3.1 The seat back shall be capable of maintaining the essentially upright position under loads of up to 150 lbf which should be applied horizontally, in each direction of travel, at the structurally most critical point. The seat back, when under load, should remain upright within 20 degrees rearward and 10 degrees forward relative to a plane normal to the cabin floor, and any permanent deformation should not significantly impede access to the exit. (Seats complying with the previous standard (GR No. 3 dated 30 November 2009) meet the new requirements and continue to be acceptable, no remedial action is therefore required).
- 4.3.2 Permanent deformation should be kept to a minimum particularly where access dimensions are close to the minima specified in this Requirement. The seat manufacturer or organisation responsible for any necessary seat modifications should declare such deformation data to enable an assessment to be made of its significance in the specific seating layout. (See paragraphs 5.3 and 5.7).

NOTE: The seat backs of aisle seats need not be maintained in the essentially upright position where this would facilitate improved access to the escape

routes, provided that the minimum access to the exit required by paragraph 4.1 is maintained.

- 4.4 The interior surface of each exit hatch shall be free of any significant projection that might inhibit or otherwise delay the exit opening. The past practice of mounting stub armrests on the exit shall be discounted.
- 4.5 The seat pan and lower back rest suspension of all seats bounding the access route(s) from the cabin aisle to the emergency exit shall be free from any gaps that might entrap a foot or other part of a person standing or kneeling on the seat. (See paragraph 5.8 of this Requirement).

5 Additional Information

- 5.1 When measuring the minimum access width between seat rows leading to Type III emergency exits, seat pans (if able to tip up) are to be down and seat backs must be in the upright (take-off and landing) position.
- 5.2 No alleviation to these requirements will be granted on the basis of deformable soft furnishings, except that, for Type III emergency exits only, some projection of the seat cushion above the lower sill height may be permitted, provided that this projection does not impede the rapid opening of the exit. Such configurations will be the subject of individual evaluation.
- 5.3 Where a particular emergency exit is larger than the defined measurements of BCAR and EASA CS, it is permissible when establishing compliance with paragraph 4.3, to assume the required minimum exit size and the maximum step-up and step-down limitations of BCAR or EASA CS provided that this required minimum exit size, when superimposed on the actual emergency exit, falls within the boundary of the actual emergency exit aperture. If this results in a vertical overlap between seat squab and lower sill it shall be shown that the resulting interference will not restrict the removal and disposal of the exit hatch.
- 5.4 For seating configurations where there is a dual access route to a Type III exit, or a single or dual access route to a Type IV exit, from the cabin aisle, a vertically projected access width of at least 6 inches should be provided. Small reductions in this access may be considered where there is evidence to demonstrate that the features of the specific configuration can achieve equivalent ease of access to, and egress rate through, the exit.
- 5.5 It is a requirement that fold-up meal tables are correctly stowed for take-off and landing. If, however, having increased the seat pitch, particular seat back meal tables are no longer used, they must either be removed from the seat, or their function inhibited to ensure that they cannot inadvertently obstruct the access to the exit. Where tables are retained for use at seats adjacent to the access route, the latches shall be sufficiently reliable and adequately protected against inadvertent release.

- 5.6 For the more conventional forward facing seating layout, the instruction placards, indicating the correct method of opening and disposal of the exit hatch, should be fixed at approximately eye level to the seated occupant on each seat immediately forward of the access route either on the upper seat back itself or on the outer face of the stowed meal table (where fitted). Where face-to-face seating makes such a location ineffective, placards, again at approximately eye level to the seated occupant, mounted on either side of the exit and visible to the occupants of the affected seat rows would be acceptable. Where such seating is not symmetrical about the exit centre line it may be necessary to locate an additional placard on the exit itself, to ensure good visibility to the seated passengers. Wherever possible, a pictorial instruction placard, comparable with that contained in the Cabin Safety Leaflet, should be used. (See paragraph 5.9 of this Requirement.)
- 5.7 Where break forward facilities are provided on seat backs in seat rows bounding access routes, it is recommended that, wherever practicable, this feature should be retained but limited in travel only to an extent necessary to ensure compliance with paragraph 4.3 of this Requirement.
- 5.8 The assessment of potential entrapment should be made both with and without the seat cushions in place. Ideally the seat upholstery and seat suspension should be free of any gaps into which it would be possible to place a foot, hand or arm in such a way as to delay or hamper free movement of passengers to the exit. Where gaps are unavoidable, their location and shape should be evaluated subjectively to assess the likely hazard. Any gap of greater than one inch into which a hand or foot may enter is considered to be unacceptable.
- 5.9 All modifications to seats, or to their installation, necessary to achieve compliance with this GR shall be the subject of the appropriate major modification approval procedure. The Instruction Placards required by paragraph 4.2 together with the associated Cabin Safety Leaflet should be submitted to the CAA Operations Inspectorate for agreement prior to the modification being submitted to the CAA Safety and Airspace Regulation Group.

Leaflet 25-110 **Flame Resistant Furnishing Materials**

NOTE: *This document was previously issued as Airworthiness Notice No. 58, Issue 7, 2 April 2004 and then as Generic Requirement (GR) No. 13 in CAP 747. The regulatory framework has changed since this GR was written and consequently this document does not form part of an EASA approved certification basis except in the case where the UK certification basis (prior to 28 September 2003) was grandfathered by EASA. Hence, although this GR was previously mandatory, it is now only applicable to those few aircraft that have a certification basis that includes this GR. The latest certification requirements, which supersede this GR, provide the same or improved safety standard. GR No. 13 was removed from CAP 747 in November 2014 as a result of the implementation of Commission Regulation (EU) No. 965/2012 (as amended) and the introduction of Part 26 – Additional Airworthiness Specifications for Operations. It is now reproduced below in its original form for reference purposes only, in order that it remains available for those relatively few aircraft to which it continues to apply.*

1 Introduction

- 1.1 The detailed requirements for compartment design safety precautions for aircraft designed in the United Kingdom are prescribed in British Civil Airworthiness Requirements (BCAR) Chapters D4-3, K4-3, G4-3 and Joint Aviation Requirements (JAR) 23.853, 25.853, 27.853 and 29.853. Suitable methods of flame resistance testing of aircraft furnishing materials are described in Appendix F to JAR-25.
- 1.2 Some imported foreign constructed aircraft are accepted for UK certification through compliance with the airworthiness standards of the country of manufacture. These standards may not be identical to either BCAR or JAR but are considered to provide acceptable levels of safety in relation to the particular aircraft types.
- 1.3 Materials used when carrying out repairs or modifications to an aircraft cabin furnishings are also required to have flame resistant properties, which are either at least equal to those of the materials used in the original design as accepted for UK certification, or in compliance with the current or UK equivalent requirements.

2 Requirements for Initial Acceptance of Materials

Wherever possible only inherently flame resistant materials shall be used. However, materials which meet the requirements by the use of a flame retardant process, applied either during or after manufacture, may also be

used provided that (since all materials may at some time be dry-cleaned or washed) the material is shown to be flame resistant when tested both before and after being subjected to three representative cleaning processes.

3 Requirements for Maintenance of Fire Resistance

3.1 Continuance of the flame resistance properties of furnishing materials may depend upon their use in service and the methods used in their cleaning. Experience has shown that:

- a) The proprietary flame retardant processes often applied to furnishing materials during or after manufacture, in order to provide the necessary flame resistant properties, may be destroyed or seriously impaired where incorrect dry cleaning, laundering or proprietary finishing processes which enhance durability and minimise soiling, are used.
- b) The application of one flame retardant process on top of another of a different type, may have the effect of inhibiting the properties of both processes.
- c) During service, seat covers become contaminated with perspiration which leaves a deposit of body salts, etc., these deposits may accumulate, impairing the flame resistance properties of the materials.
- d) Disinfectants, etc., are often sprayed from aerosol containers in aircraft cabins. The accumulation of these agents may also affect the long term flame-resistant properties of the furnishing materials.

3.2 Operators and maintenance Organisations are reminded, therefore, that they must have adequate control over the cleaning of aircraft furnishing materials. For this, they need to have a knowledge of the material type, the recommended cleaning or proprietary finishing processing methods, the effects of time in service on the flame resistance properties, the flame retardant processes applied, if any, and the method of reapplication of such a process, where this is necessary. It is not acceptable to place reliance on unsubstantiated claims concerning the continuance of flame resistant properties of a material after durability or additional flame retarded processes have been applied. Where such processes have been applied, there is a need to prove the continued acceptability of a particular material or process in service, and, therefore, further flame resistance tests must be conducted in accordance with requirements identified in paragraphs 1.1 and 1.2 of this Generic Requirement.

Leaflet 25-120 Improved Flammability Test Standards for Cabin Interior Materials

NOTE: *This document was previously issued as Airworthiness Notice No. 61, Issue 4, 2 April 2004 and then as Generic Requirement (GR) No. 14 in CAP 747. The regulatory framework has changed since this GR was written and consequently this document does not form part of an EASA approved certification basis except in the case where the UK certification basis (prior to 28 September 2003) was grandfathered by EASA. Hence, although this GR was previously mandatory, it is now only applicable to those few aircraft that have a certification basis that includes this GR. The latest certification requirements, which supersede this GR, provide the same or improved safety standard. GR No. 14 was removed from CAP 747 in November 2014 as a result of the implementation of Commission Regulation (EU) No. 965/2012 (as amended) and the introduction of Part 26 – Additional Airworthiness Specifications for Operations. It is now reproduced below in its original form for reference purposes only, in order that it remains available for those relatively few aircraft to which it continues to apply.*

1 **Applicability**

This Generic Requirement is applicable to all UK registered aeroplanes over 5700 kg MTWA, used for the purpose of Public Transport and certificated to carry 20 or more passengers, and of a type for which a Type Certificate was issued (whether in the UK or elsewhere) on or after 1 January 1958.

2 **Introduction**

- 2.1 Analysis of aircraft accidents in which cabin fire has been a major factor has indicated to both the FAA and the CAA that currently approved cabin interior materials should meet more severe flammability test standards to reduce the risk of an uncontrolled in-flight cabin fire and extend the survival time in a ground fire emergency.
- 2.2 Cabin interior material flammability, smoke and toxic emissions are some of the critical factors which affect cabin occupant survivability. Over the past twenty years there has been extensive research carried out, particularly in the USA, in an attempt to quantify the hazards and to define meaningful test methods and airworthiness standards.
- 2.3 Recent FAA research work, involving full scale fire tests, has established a significant correlation between flammability characteristics and both smoke and toxic emissions. As a result they have placed great emphasis on the introduction of fire-hardened materials into aircraft (i.e. materials with higher

ignition temperatures, reduced heat release rates and lower content of thermally unstable components).

- 2.4 The FAA (Docket No. 24594) had amended FAR Part 25 and 121 (Amendments 25-61 and 121-189 respectively) to require a new flammability test standard for cabin sidewalls, ceilings, stowages, partitions, galleys, etc. As a result of an extended comment period, FAA Docket No. 24594 has been further revised and now amends FAR Parts 25 and 121 at Amendments 25-66 and 121-198 respectively. Similar amendments have now been incorporated in JAR-25 at Change 13. This new test standard sets a limit for the heat release rate and smoke emission from cabin materials when exposed to a source of radiant heat. Using the modified Ohio State University (OSU) rate of heat release apparatus for Heat Release Rate, testing has been adopted by the FAA because of its good correlation with full-scale fire tests. The modified NBS smoke chamber is used for smoke emission testing.
- 2.5 The CAA is in full agreement with the new FAA flammability and smoke emission test standards introduced by FAR Amendments 25-61 and 121-189 as amended by 25-66 and 121-198 and intends, by this Generic Requirement, to require the same standards for those aeroplanes defined in paragraph 1.
- 2.6 Under the provision of this Generic Requirement, aircraft already in service may continue without incorporating materials that comply with the new flammability and smoke emission test standards until such a time as the cabin interior is substantially renewed. In due course the CAA may consider it necessary to propose dates by which all aircraft shall be in compliance.

3 Compliance

- 3.1 With effect from 20 August 1988, but prior to 20 August 1990, all aeroplanes defined in paragraph 1 above, which are either newly manufactured or are the subject of a substantially complete cabin interior renewal, shall comply with the requirements of paragraph 4.1 of this Generic Requirement.
- 3.2 With effect from 20 August 1990, all aeroplanes defined in paragraph 1 above, which are either newly manufactured or are the subject of a substantially complete cabin interior renewal, shall comply with the requirements of paragraph 4.2 of this Generic Requirement.
 - 3.2.1 The CAA may be prepared to grant a dispensation for specific components of the cabin interior which do not meet the applicable flammability and smoke emission requirements, provided that special circumstances exist which makes compliance impractical. Such dispensations will be limited to aircraft which are newly manufactured or the subject of a substantially complete cabin interior renewal before 20 August 1991.

- 3.2.2 A request for such a dispensation must include full details of the steps being taken to achieve compliance, acceptable reasons for such non-compliance and a thorough and accurate analysis of each component.

4 Requirements

- 4.1 In addition to meeting the existing flammability test standards contained in BCAR Chapter D4-3, paragraph 6.1 or JAR 25.853, cabin interior ceiling and wall panels (other than lighting lenses), partitions, and the outer surfaces of galleys, large cabinets and stowage compartments (other than underseat stowage compartments and compartments for stowing small items such as magazines and maps), shall satisfy the test standards of Part IV of Appendix F of JAR-25, except that the total heat release over the first two minutes of sample exposure shall not exceed 100 kilowatt-minutes per square metre, and the peak heat release rate shall not exceed 100 kilowatts per square metre.
- 4.2 In addition to meeting the existing flammability test standards contained in BCAR Chapter D4-3, paragraph 6.1 or JAR 25.853, cabin interior ceiling and wall panels (other than lighting lenses), partitions, and the outer surfaces of galleys, large cabinets and stowage compartments (other than underseat stowage compartments and compartments for stowing small items such as magazines and maps), shall satisfy the test standards of Part IV and V of Appendix F of JAR-25.

5 Additional Information

- 5.1 For the purpose of this Generic Requirement, the term 'substantially complete cabin interior renewal', has been used to cover the renewal of all sidewall panels, ceiling panels and/or overhead stowages, whether this is done at one refurbishment or progressively over a period of time as part of a planned cabin interior renewal programme.
- 5.2 The requirements of this Generic Requirement are not applicable to individual cabin interior components which are refurbished or have to be replaced due to unserviceability, e.g. individual sidewall or ceiling panels or overhead stowage doors. However, where these components are newly manufactured the CAA strongly recommends that they should meet the appropriate requirements of this Generic Requirement.
- 5.3 The requirements of this Generic Requirement are not normally applicable to the internal structures of galleys and overhead stowages, floor panels and floor coverings, transparent or translucent components such as lenses used in interior lights, illuminated signs and window anti-scratch panels, and other small cabin items such as door and window mouldings, curtains, window shades, seat trays, arm rests and parts of the passenger service units but
-

see ACJ 25.853. However, these requirements would be applicable to large surface panels of passenger service units.

- 5.4 If there is any uncertainty as to the applicability of this Generic Requirement the CAA should be consulted for clarification.

Leaflet 25-130 Fire Precautions – Aircraft Toilets

NOTE: *This document was previously issued as Airworthiness Notice No. 83, Issue 5, 22 March 2002 and then as Generic Requirement (GR) No. 20 in CAP 747. The regulatory framework has changed since this GR was written and consequently this document does not form part of an EASA approved certification basis except in the case where the UK certification basis (prior to 28 September 2003) was grandfathered by EASA. Hence, although this GR was previously mandatory, it is now only applicable to those few aircraft that have a certification basis that includes this GR. The latest certification requirements, which supersede this GR, provide the same or improved safety standard. GR No. 20 was removed from CAP 747 in November 2014 as a result of the implementation of Commission Regulation (EU) No. 965/2012 (as amended) and the introduction of Part 26 – Additional Airworthiness Specifications for Operations. It is now reproduced below in its original form for reference purposes only, in order that it remains available for those relatively few aircraft to which it continues to apply.*

1 **Applicability**

This Generic Requirement is applicable to all aircraft over 5700 kg operating for the purposes of public transport.

2 **Introduction**

- 2.1 In view of the history of in-flight fires which have occurred in the toilet compartments of large transport category aeroplanes, a survey has been conducted to re-appraise the fire precautions on the various types of aircraft used by UK operators.
- 2.2 The results of this survey have shown that in some instances the design of receptacles (e.g. towel dispensers, waste containers), provided within toilet areas for the carriage of flammable materials and in particular flammable waste, does not comply with the current interpretation of published airworthiness requirements. In other instances the receptacles are not sufficiently robust to withstand the effects of wear and deterioration in service. The survey also showed that, regardless of notices prohibiting smoking in toilets, smoking does occur, and that, even when ashtrays are provided, they are often not used, and cigarette ends are deposited in other receptacles.
- 2.3 The purpose of this Generic Requirement is to publish requirements aimed at reducing the probability of persons smoking in toilet compartments and at minimising the potential fire hazard caused by persistent smokers.

3 Background

- 3.1 When Airworthiness Notice No. 83 was first issued on 22 August 1974, the CAA required that an inspection be completed on toilet receptacles within one calendar month from the date of issue with repeat inspections at 1000 hourly intervals, however, as a result of a further survey it was concluded that some aircraft toilets had been allowed to deteriorate and were therefore out of compliance.
- 3.2 In order to re-establish the effectiveness of the Notice, Letters to Operators (Nos. 554 and 554A) dated 11 July 1983 and 21 July 1983 respectively, were issued, which revised the inspection periods.

4 Requirements

4.1 Inspection

- 4.1.1 At intervals not exceeding 72 hours elapsed time, or at such other intervals as may be agreed with the CAA on the basis of available data, the following inspection shall be performed:
- a) All receptacles shall be inspected to ascertain that all entry flaps or doors still operate, fit, seal and latch correctly, ashtrays are fitted, notices installed and receptacle stowage compartment is clean with all debris removed.
 - b) Any defects revealed by the inspection of a) are corrected.
- 4.1.2 This inspection shall be included in the Maintenance Schedules using the normal procedure.

4.3 Re-Assessment

- 4.3.1 Except where agreement has been obtained from the CAA that compliance would not be justified in the circumstances of a particular case, the design of all receptacles provided in the toilet compartments of aircraft over 5700 kg, operated for the purposes of public transport, shall be re-assessed against paragraph 5 of this Generic Requirement, and proposals shall be made, by the operators of such aircraft to the CAA for the incorporation of modifications necessary to show compliance, including a date (to be agreed by the CAA). The operator should consult the aircraft manufacturer regarding such modifications.
- 4.3.2 In the case of British manufactured aircraft, the CAA is discussing with the aircraft manufacturers suitable modifications to ensure compliance with paragraph 5 of this Generic Requirement.

5 Interpretation of Requirements

- 5.1 BCAR Section D, Chapter D4-3 paragraph 6.4.1 states that all receptacles for used towels, papers and waste shall be constructed of materials resistant to fire. The receptacles shall incorporate covers or other provisions for containing fires if started in the receptacle. Similar wording is provided in JAR 25.853(h) and CS 25.853(h).
- 5.2 For compliance to be shown, such receptacles (but see 5.4 for towel dispensers) shall be constructed of materials which are flame resistant¹, and which in addition, will retain sufficient mechanical properties as to contain such a fire as may develop by burning of materials such as paper towels, as may be within the receptacle. (It should be noted that although a thermoplastic material may be flame resistant it would not necessarily retain adequate mechanical properties in the case of a fire.) The receptacle shall be completely enclosed with the exception of a self-closing entry flap or door, which itself shall be rigid, and when closed, form as airtight a seal as is practicable. Entry flaps or doors shall be designed so that they remain self-closing even after exposure to a fire within the receptacle.
- 5.3 It is, however, permissible for receptacles to be open topped provided that they are mounted in a cabinet which itself complies with 5.2. In this instance, the door of the cabinet shall be of a robust construction and such as to ensure an adequate seal and to withstand misuse in service. Such cabinets shall not contain other flammable materials, potential fire sources (e.g. electrical apparatus) or apertures which would either allow air to feed a fire or permit a fire to spread beyond the cabinet (e.g. through apertures provided for services).
- 5.4 It is accepted that some receptacles, e.g. paper towel dispensers, cannot readily be designed to meet the above requirements. In such instances they shall be so designed and positioned within the compartment to ensure that:
- the likelihood of the depositing of cigarette ends, etc., into them is minimised, and
 - a fire, which could be expected to start in another container, cannot readily spread to them; for example, a paper towel dispenser must not be positioned adjacent to, or immediately above, either the entry flap or door of a waste container or an ashtray provided in the compartment.

¹ Suitable methods for flame resistance testing are contained in JAR-25 Appendix F.

INTENTIONALLY LEFT BLANK

Chapter 28 Fuel

Leaflet 28-10 Microbiological Contamination of Fuel Tanks of Turbine Engined Aircraft

1 Introduction

This leaflet supersedes Airworthiness Notice No. 21 Issue 3 dated 15 May 1970 which was issued following reports of contamination of fuel tanks.

2 Background

- 2.1 Reports have been received that aircraft regularly operating in climatic conditions such as those prevailing between the latitudes 30° North and 30° South, have been contaminated in the fuel tanks by fungus. Another aircraft, regularly operating from the United Kingdom, was found to have localised areas of heavy growth when inspected after standing in a heated hangar for two months with fuel in the tanks. It is considered that the storage conditions were a contributory factor.
- 2.2 In one case contamination was found during an investigation into the cause of erratic fuel contents indication, when white crusty deposits and brown stains were seen on the probes. Further examination revealed the presence of brown/black slimes adhering to horizontal upward facing surfaces within the tanks. Examination by the Commonwealth Mycological Institute, Kew, confirmed that this substance was a fungal growth of the type *Cladesporium Resinae*.

3 Effects of Contamination

- 3.1 The problems associated with microbiological growths have been known for some years and research into their behaviour has been conducted throughout the world. In the case of *Cladesporium Resinae*, the spores of the fungus can exist in a dormant state in kerosene fuels in most parts of the world. These will only develop when in contact with water in fuel at temperatures such as those reached when the aircraft or storage tanks are exposed to a warm ambient temperature such as radiation from the sun for long periods in a tropical or sub-tropical environment, or prolonged periods in a heated hangar. If developing fungus forms on water not drained off and which adheres to the tank surfaces, the fungus is able to absorb water later introduced with fuel or condensing following a cold soak.
- 3.2 Where fungus has formed there is a probability that corrosion will occur. Corrosion has been found where fungus had formed on the bottom tank skin, on the chordal support member in the wing root and on fuel pipes within the tank. In some cases aircraft have been sufficiently affected to necessitate replacement of some component parts.
- 3.3 The fungus itself, if dislodged by fuel during refuelling, can obstruct fuel filters.

4 Inspection

- 4.1 Operators uplifting fuel or operating regularly in areas having high normal ambient temperatures and high humidity or where fungus development is known to have been encountered, are advised to scrutinise tank areas for signs of fungus whenever access is gained for any purpose. It is further recommended that, for aircraft operating under these conditions, Maintenance Schedules should be amended to include a visual internal tank check at periods prescribed by the aircraft manufacturer. It is also important, whenever fuel tanks are inspected, to ensure that all passage ways between rib cleats, etc. are not obstructed, so that a drainage path for water is maintained at all times. If the aircraft has been standing in a heated hangar for a prolonged period the fuel in the tanks should be treated with biocide (see paragraph 5).
- 4.2 If contents gauges give suspect indications, immediate consideration should be given to the possibility that tank probes may be contaminated with water and/or fungus and appropriate inspections should be carried out.
- 4.3 Whenever fuel filters are checked, they should be closely examined for the presence of slimes of any colour.
- 4.4 The need to prevent water collection by good maintenance practices and control of fuel supplies is emphasised. A high degree of protection can be maintained by strict adherence to water drain checks before and after refuelling and again, if the aircraft has been standing for any length of time, before the next flight. Fuel quality control checks should be rigorously applied.

5 Treatment

- 5.1 If fungus is discovered, the fuel system should be cleaned as soon as possible by a method approved by the aircraft manufacturer and the engine manufacturer. It must be appreciated that if the fungus is allowed to develop, cleansing and rectification could become a major operation involving grounding the aircraft for a long period.
- 5.2 It is strongly recommended that when aircraft operate in an area where fungal growth can be encountered, or where there is any possibility of temperatures in the fuel tanks frequently rising above 25°C, a fungicide additive should be used in the fuel as approved by the aircraft manufacturer and the engine manufacturer. The frequency of treatment and the dilutions prescribed by the aircraft manufacturer and the engine manufacturer must be adhered to. Introduction of an unapproved fungicide or inhibitor may jeopardise the safe operation of the aircraft.

Leaflet 28-20 The Use of Motor Gasoline (Mogas) and Unleaded Aviation Gasoline (Avgas) UL 91

1 Introduction

- 1.1 This Leaflet is to inform all owners and operators of aircraft powered by spark-ignition piston engines about the use of Motor Gasoline (Mogas) and Unleaded Aviation Gasoline (Avgas) UL 91. It also contains guidance on the content of fuel related Generic Concessions and information on how to seek approval of the use of Mogas or UL 91 in aircraft or engines not already covered by the Concessions.

2 Scope

- 2.1 Because difficulties had been experienced in obtaining Avgas, particularly in small quantities, the CAA was asked to permit the use of more readily available Mogas in certain light aircraft with low compression ratio unsupercharged engines. Such permissions were granted via Airworthiness Notices 98, 98A, 98B and 98C. These Notices have since been transferred to CAP 747 'Mandatory Requirements for Airworthiness', as Generic Concessions (GCs) 2, 3, 4 and 5 respectively, which contain exemptions issued to allow the use of different types of Mogas with various types of aircraft and engines, subject to conditions specified therein. These GCs cover both certain Annex II (non-EASA) and, under Grandfather Rights, some EASA aircraft. (Regulation (EC) 216/2008 identifies EASA and non-EASA aircraft).
- 2.2 Since the publication of these GCs, the composition and properties of some Mogas fuels has changed and it is becoming increasingly difficult to obtain Mogas that does not contain any alcohol. With the exception of microlight aircraft, the use of Mogas containing alcohol is generally prohibited in aircraft. A new unleaded aviation fuel, Avgas UL 91 is now becoming available in the UK and a new Generic Concession No. 7 is to be published to facilitate its use in certain types of Annex II aircraft. (EASA has published a Safety Information Bulletin to cover the use of UL 91 in EASA aircraft – Section 7, below refers).

NOTE: Owners of LAA aircraft may use LAA Airworthiness Approval Notice LAA-999-413 Supplement 5 (or later) as an approval to use UL 91, subject to the conditions stated therein.

3 Unleaded Avgas UL 91

- 3.1 Unleaded Avgas UL 91 is a new type of unleaded aviation fuel with similar properties to those of Avgas 100LL but without the addition of tetraethyl lead (TEL). The fuel is broadly equivalent to EN228 unleaded Mogas but does not contain octane boosting additives such as ethanol or ETBE, which are commonly included in Mogas fuels.
- 3.2 The absence of Mogas additives in unleaded Avgas eliminates material compatibility issues surrounding the presence of ethanol in fuel and its effect on certain components. Additionally, aircraft operating with unleaded Avgas are not required to observe the maximum altitude and fuel temperature restrictions placed upon aircraft operating with unleaded Mogas.
- 3.3 As an aviation fuel, the production and delivery of UL 91 is subject to stringent quality control procedures in order to protect the fuel from contamination and to maintain its quality and traceability. Additionally, the Air Navigation Order places obligations on the managers of aviation fuel installations at aerodromes and personnel carrying out refuelling to apply procedures to maintain the quality of the fuel.

4 The Generic Concessions (GCs)

4.1 GC 2 – The use of leaded Mogas in certain airframe/engine combinations

GC 2 permits the use of leaded Mogas conforming to BS 4040 (four-star petrol) with certain airframe/engine combinations, provided that the fuel is obtained from an aerodrome aviation fuel installation in full compliance with the relevant requirements of the ANO (equivalent to the storage and quality control procedures used for Avgas). GC 2 Schedule 1 provides a listing of all aircraft/engine combinations approved to use leaded Mogas conforming to BS 4040.

NOTE: Because BS 4040 four-star is generally no longer available, the applicability of GC 2 is limited.

4.2 GC 3 – The use of leaded Mogas obtained from a filling station forecourt in certain light aircraft

GC 3 provides an exemption against the ANO requirements for fuel to be obtained from a managed aviation installation and permits the use of BS 4040 leaded Mogas obtained from a filling station forecourt in microlight aeroplanes, gyroplanes, powered sailplanes and single-engine aircraft/engine combinations under 2730 kg that are listed in GC 2 Schedule 1.

4.3 GC 4 - The use of unleaded Mogas obtained from a filling station forecourt in microlight aeroplanes

GC 4 also provides an exemption against the ANO requirements for fuel to be obtained from a managed aviation installation and permits the use of unleaded Mogas obtained from a filling station forecourt in microlight aeroplanes, provided that the fuel conforms to EN228 and the aircraft is already approved to use unleaded EN228 or BS 7070 Mogas.

4.4 GC 5 - The use of unleaded Mogas obtained from a filling station forecourt in certain light aircraft

4.4.1 GC 5 permits the use of unleaded Mogas obtained from a filling station forecourt in the aircraft identified in its Schedule 2, provided that the fuel conforms to EN228 and contains NO ALCOHOL.

4.4.2 GC 5 Schedule 2 provides a listing of the aircraft and airframe/engine combinations approved to use alcohol-free EN228 Mogas. This listing is divided into three groups as follows:

- Group 1 covers aircraft for which the Type Certificate Holder has shown compliance with the applicable requirements, and for which approval to use EN228 Mogas is specified in the Flight Manual or other approved document.
- Group 2 covers aircraft embodying FAA STC-approved modifications to both the airframe and the engine. Each airframe/engine combination, along with details of the STC required to be embodied before EN228 may be used, is listed. The STCs have been validated by the CAA.
- Group 3 covers aircraft embodying FAA STC-approved modifications to the engine only. Each airframe/engine combination, along with details of the STC required to be embodied before EN228 may be used, is listed. The STCs have been validated by the CAA.

4.5 GC 7 – The use of unleaded Avgas UL 91 in Annex II aircraft

4.5.1 GC 7 permits the use of UL 91, subject to one of the following conditions:

- The aircraft is already approved for operations with 100LL Avgas and the engine manufacturer has confirmed acceptability of UL 91 Avgas by means of a Service Letter, Service Instruction or other published service information; or
 - The aircraft is already approved to use RON 95 EN228 Mogas (note that this may require the embodiment of modifications to the engine or to both the engine and the airframe, as detailed in GC 5); or
 - The aircraft is already approved to use 80/87 Avgas and TEL is not required for engine lubrication. This can be shown by evidence from the engine manufacturer's original instructions or evidence that the engine was produced prior to the introduction of lead in fuel. Care must be taken to ensure that no modifications have been subsequently introduced that affect the fuel specification which can be used.
- 4.5.2 The CAA takes no responsibility for infringement of the manufacturer's warranty, accelerated deterioration of the engine or aircraft components, or any other long-term deleterious effects which may be associated with the use of this fuel.
- NOTE:** Owners of aircraft under the airworthiness administration of the Light Aircraft Association (LAA) may refer to LAA Airworthiness Approval Note LAA-999-413 supplement 5.

5 General information on the use of Mogas

- 5.1 GCs 2-5 listed above provide information on the precautions that must be taken and the operational limitations that must be observed when using Mogas. It is strongly recommended that the applicable Concessions be consulted before using Mogas.
- 5.2 CAA Safety Sense Leaflet 4, 'Use of Mogas' provides practical advice on the use of Mogas, including fuel handling and testing guidance, maintenance precautions and both pre-flight and in-flight precautions. This leaflet is available on the CAA website.

6 New Mogas/Unleaded Avgas UL 91 approvals

- 6.1 GCs 2, and 5 are frozen and will not be amended – many of the permissions that were granted were for types of aircraft and engine now under EASA regulation. These have been adopted by the EASA under Grandfather Rights and cannot be altered by the CAA.
- 6.2 Any new approvals for Annex II aircraft will be granted on an individual basis. If the use of Mogas or UL 91 is requested for an aircraft not already covered by the GCs then enquiries should be directed to the engine manufacturer in the first instance. Where the engine manufacturer no longer exists, or the engine type is no longer supported, application for modification approval should be made to the CAA Applications and Approvals.

7 Reference Publications

CAP 747, 'Mandatory Requirements for Airworthiness', Generic Concessions 2 through 5 and 7.

CAA Safety Sense Leaflet 4, 'Use of Mogas'.

EASA Safety Information Bulletin No: 2011-01R2 – 'Unleaded Aviation Gasoline (Avgas) UL 91,' or a later revision.

8 **Queries**

- 8.1 Any queries or requests for further guidance concerning this Leaflet should be addressed to:

Airworthiness Evaluation and Surveillance - Engineering
Civil Aviation Authority
Safety Regulation Group
Aviation House
Gatwick Airport South
West Sussex
RH6 0YR

Email address: department.certification@caa.co.uk

Chapter 31 Indicating/Recording Systems

Leaflet 31-10 Cockpit Voice Recorder System Fairchild A100 Series

1 Introduction

- 1.1 This SMP establishes minimum maintenance tasks and their intervals for the Fairchild A100 Series Cockpit Voice Recorder (CVR) System. These maintenance tasks take account of the Component Maintenance Manual 23-70-01, latest issue. Account is also taken of the lack of failure detection within the system other than that provided by the limited pre-flight test facility.
- 1.2 The maintenance intervals stated in this SMP are based on elapsed calendar time. These intervals should be interpreted as the maximum permissible periods between the maintenance tasks specified. Operators may submit Maintenance Schedules based on flight hours provided that fleet operating statistics show that the calendar time limits are unlikely to be exceeded.
- 1.3 Operators will need to review the results of their CVR sampling programme (see paragraph 8) and, where shown to be necessary, reduce maintenance intervals until an acceptable level of serviceability has been re-established. Such a review should be made annually and a report should be sent to the CAA.

Item	Equipment	Task	Maximum Interval	Interpretation
1	Cockpit Voice Recorder System	Operational check	Daily (pre-flight post-flight)	Confirm serviceability using TEST function on CVR controller (flight crew check).
2		Check/Functional Test	Not exceeding 6 months elapsed time	Inspect installation. Confirm, by means of the CVR controller monitor jack, proper recording on each voice channel from area microphone(s), receiver audio, sidetone, interphone, public address (if recorded) and boom microphone (including 'hot mike' function, i.e. interphone OFF). Confirm proper functioning of the inhibit logic for bulk erase.
3		Functional Test (helicopters only)	Not exceeding 12 months elapsed time	Confirm proper recording of data.

Item	Equipment	Task	Maximum Interval	Interpretation
4	Cockpit Voice Recorder	Check	Not exceeding 24 months elapsed time	Remove CVR for inspection, cleaning of erase/recording heads and tape transport mechanism, replacement of worn parts, weighing of Thermopack insulation assembly and test as required by the Component Maintenance Manual.
				<p>NOTES:</p> <p>1) Before cleaning is attempted, the quality of the recording already on the tape should be evaluated. Where indicated by the evaluation, appropriate maintenance should be performed on the aircraft from which the CVR was removed.</p> <p>2) The Component Maintenance Manual lists various items which may need to be replaced between 7000 and 9000 equipment operating hours.</p>
5	Ditching Sensor (Helicopters)	Check/Functional Test	Not exceeding 24 months elapsed time	Confirm proper sensor function. Test may be performed in situ if practical.
6	Crash sensor (where fitted)	Check/Functional Test	As stated by the vendor	Comply with the instructions issued by the vendor.
7	Underwater Locator Beacon	Check/Functional Test	As stated by the vendor	Comply with the instructions issued by the vendor.
8	Cockpit Voice Recorder System	Sample check * in accordance with criteria and procedures agreed with CAA	As agreed between operator and CAA	Remove CVR immediately after flight. Replay and evaluate quality of in-flight recording.
		<p>* NOTES: (1) The objective of this sample check is to confirm the adequacy of maintenance and to detect any deterioration of recording quality, e.g. due to vibration, electrical interference, acoustic noise or intermittent defects.</p> <p>(2) Operators will need to submit, to the CAA, proposals for their CVR sampling programme. Account will need to be taken of route structure, number of aircraft in the fleet type, and their annual utilisation. See also paragraph 1.3.</p>		

Chapter 32 Landing Gear

Leaflet 32-10 Tyres

1 Introduction

1.1 This Leaflet provides general guidance and advice on the care and maintenance of aircraft tyres. It should be read in conjunction with the manufacturer's manuals for the tyres concerned, since minor variations may occur between the various manufacturers' products. The topics discussed are as follows:

Paragraph	Topic
1	Introduction
2	General
3	Tyre Markings
4	Fitting Tubed Tyres
5	Fitting Tubeless Tyres
6	Wheels Suitable for Tubed or Tubeless Tyres
7	Inflation after Fitting
8	Testing
9	Tyre Creep
10	Maintenance of Tyres
11	Removing Tyres
12	Inspection of Tyres and Tubes Removed from Aircraft
13	Repair of Tyres and Tubes
14	Remoulding Tyres
15	Storage
16	Records

1.2 Information on the maintenance and overhaul of wheels and brakes is given in Leaflet 32-20.

1.3 The high take-off and landing speeds of most transport aircraft have resulted in tyres being operated under increasingly severe and intensive loading conditions, therefore a high standard of maintenance and inspection is essential at all times to ensure the continued serviceability of the tyres. The CAA recommends that, in all cases where doubt exists regarding the condition of aircraft tyres, the tyres should be changed and the tyre manufacturer's representative should be consulted.

2 General

2.1 Tubed Tyres

Tubed aircraft tyres consist of two component parts, i.e. inner tubes and outer tyres. The general manufacture of a typical tyre is shown in Figure 1, but the detailed manufacture varies considerably according to the manufacturer and the duties for which the tyre is intended.

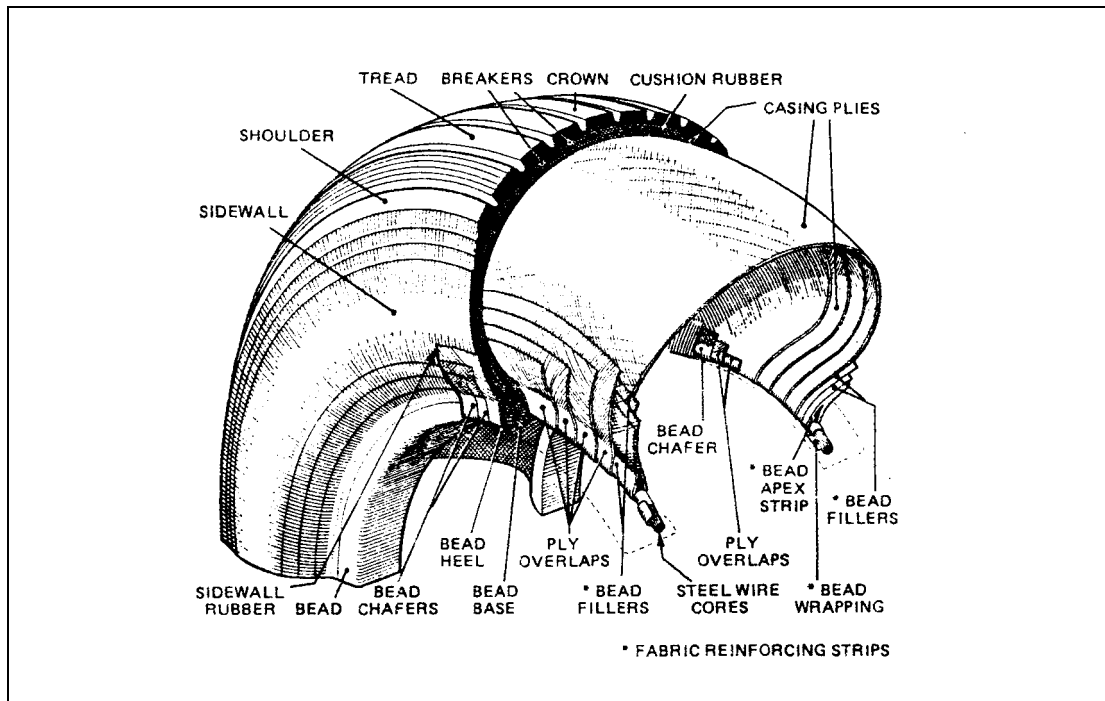

Figure 1 Manufacture of Typical Tubed Tyre

2.2 Tubeless Tyres

Basically a tubeless tyre is identical to a tubed tyre except that the tube is replaced by an air-retaining inner lining and the beads are designed to prevent air leakage at the rim of the wheel. Some of the advantages derived from the use of tubeless tyres include about 7½% saving in weight compared with using a tyre and tube, a reduction in permeability losses, cooler running by about 10°C, less danger of deflation due to puncture and the elimination of tube troubles. Because it is necessary to keep the bead areas in good condition, tubeless tyres are not fitted to well-base wheels.

2.3 High Pressure Tyres

Some aircraft tyres are inflated to pressures of 1400 kN/m² (200 lbf/in²) or more. Because of their strength and rigidity, such tyres, whether tubed or tubeless, are normally fitted only to divided or detachable-flange wheels. Special precautions are necessary to protect personnel from injury during initial inflation (paragraph 7.1).

2.4 Tyre Venting

During manufacture all tubeless tyres are provided with vents by partially piercing the rubber covering with an awl (of approximately 1.5 mm (0.0625 in) diameter) at several places, usually around the tyre immediately outside the area of the wheel flanges, but, in some instances, also on the crown and shoulder areas. These vents are provided as a means of releasing air under pressure from the tyre casing and are

marked with a green or grey spot. Such air may be residual air in the casing cords after manufacture, which is compressed to a high pressure on inflation of the tyre, or air which accumulates in the casing by normal permeation through the inner lining. If a free passage of air were not provided, the residual or permeating air could cause looseness or lifting of rubber on the tread or sidewalls of the tyre. Aircraft tyres to which tubes are fitted, are vented through the complete casing at the bead position in order to allow air trapped between the tube and tyre to escape.

2.5 Tread Patterns

- 2.5.1 The tread pattern on a tyre is usually designed to suit specific operating conditions, aircraft weights and aircraft take-off and landing speeds.
- 2.5.2 Ribbed (i.e. circumferentially grooved) tread tyres are probably used more than any other types and there are a number of variations on the basic pattern such as the number of ribs and the width of grooves. A ribbed tread provides a good combination of long tread wear, good traction and directional stability, particularly on hard surfaced runways.
- 2.5.3 Diamond pattern (or 'all-weather') tyres are also widely used and give good performance on all types of surfaces. They are particularly suitable for unpaved (e.g. turf or packed earth) airfields.
- 2.5.4 Plain tread was at one time very common, particularly on British aircraft, but has gradually been replaced by ribbed and diamond pattern treads. It is, however, still used on some light aircraft and helicopter tyres.
- 2.5.5 Some nosewheels are fitted with tyres having twin-contact tread, i.e. a tread consisting of a large circumferential rib at each side of the crown, which is designed to assist in preventing shimmy.
- 2.5.6 Some nosewheel tyres are also fitted with a water deflector (or 'chine') on the upper sidewall, to deflect water away from rear-mounted engines. This deflector may be on one side for twin-wheel installations or on both sides for single-wheel installations.
- 2.5.7 Water dispersing treads, which have many small holes incorporated in the crown and shoulder rubber, are also fairly common as a means of helping to prevent aquaplaning.

3 Tyre Markings

- 3.1 Tyres have certain markings imprinted on their sidewalls for identification purposes. These markings vary according to the manufacturer but usually include size, part number, serial number, date of manufacture, tubed/tubeless, speed rating, ply rating and the type and number of retreads carried out. These markings are explained in paragraphs 3.2 to 3.8.

3.2 Size

Tyres are identified for size in the following way:

Example: 26 x 10·00–18.

The first number (26) indicates the outside diameter (A in Figure 2) in inches.

The second number (10·00) indicates the width (C in Figure 2) in inches.

The third number (18) indicates the bead diameter (B in Figure 2) in inches.

It will be found that some tyres do not specify all three dimensions. Some tyres of American manufacture may quote only the outside diameter (e.g. 26) but otherwise

the tyre width will always be stated, either preceded by the outside diameter (e.g. 26 x 10·00) or followed by the bead diameter (e.g. 10·00–18).

NOTE: Dimensions (A) and (C) may, alternatively, be quoted in millimetres.

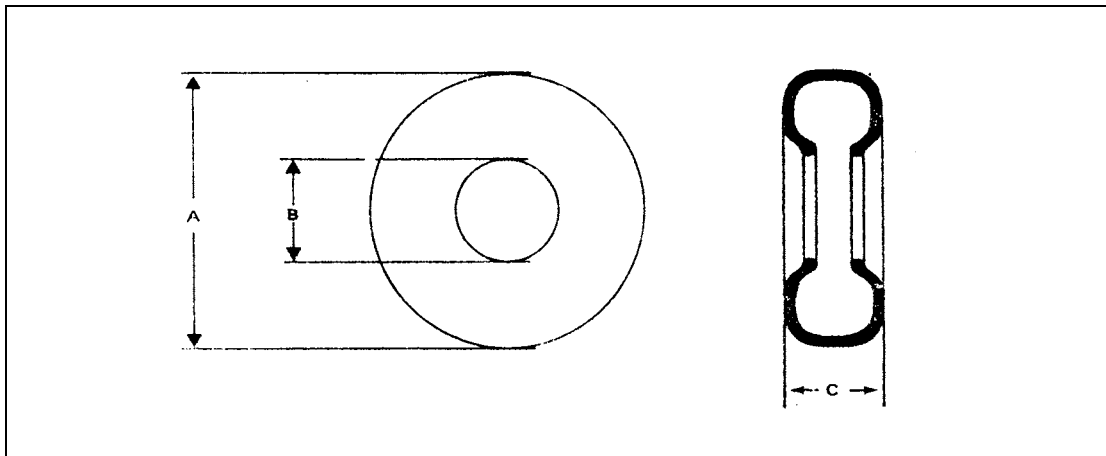

Figure 2 Tyre Dimensions

3.3 Part Number

The part number usually includes the manufacturer's identification, the drawing to which the tyre is manufactured and letters to indicate the tread type and whether it is tubed or tubeless. The part number is the only positive means of identifying a tyre and size markings alone should not be used for this purpose. Example: DR 7153 T.

3.4 Serial Number

The serial number is usually marked in conjunction with the date of manufacture, which may be in the form of a code indicating the day, week, or month and the year.

Example: 2283 Nov 72 or 23202283.

3.5 Ply Rating

The term 'ply rating' is used to identify a tyre with its maximum recommended load and pressure. It is the index of the tyre strength and does not necessarily represent the number of cord plies used in its manufacture. The marking may be imprinted in full, e.g. 10 PLY RATING, or abbreviated, e.g. 10PR.

3.6 Speed Rating

Most high speed tyres (i.e. those which may be used at speeds over 160 mile/h) have the speed rating imprinted on the tyre to indicate the maximum speed for which they are designed, e.g. 200 mile/h.

3.7 Other Markings

Other markings which may be found on new tyres include the following:

- a) Military Stores Reference Number.
- b) Green or grey spots indicating the positions of the awl vents.
- c) A red spot or triangle indicating the light part of the tyre.

3.8 Retreads

Retreaded tyres are usually marked in accordance with a system peculiar to each manufacturer. The markings usually include the tyre part number, the name of the

retreader, the number and date of the last retread and in the case of retreads in which the sidewalls are covered with new rubber, the tyre serial number, manufacturer, speed, size and ply rating.

4 Fitting Tubed Tyres

- 4.1 The successful fitting of tyres is not difficult provided that a suitable procedure is employed and the correct type of tool is used for each operation. However, careful attention to detail is essential throughout the process, since visual inspection after the tyre is fitted is obviously limited.
- 4.2 When a new tyre is required on those aircraft fitted with tubed tyres, it is advisable to fit a new tube since any stretching or local thinning present in the original tube may result in the formation of wrinkles during refitting, leading to early failure of the tube. If it is decided to refit the original tube it should be carefully examined for signs of damage or defects before refitting.
- 4.3 Care should be taken to ensure that the tyre and tube are of the correct size and of types authorised for use on the particular wheels of the particular aircraft. It is also important to ensure that the correct type of valve cap is fitted, since an incorrect type of cap may foul the airframe structure when the landing gear is retracted.

4.4 Tyre Balance

The balance of tyres and tubes is checked and brought within specified limits by the tyre manufacturer (often by the addition of a balancing patch). Where balance is not perfect the lighter side of the tyre is marked with one or two circular or triangular spots above the bead heel and the heavier side of the tube is marked with a red or yellow band approximately 10 mm (0.375 in) wide; fitting the tyre and tube with these markings together will achieve the best state of balance.

4.5 General Fitting Precautions

When fitting tyres and tubes to any type of wheel, the following general precautions should be observed:

- a) Care must be taken to ensure that nothing is left inside the tyre, e.g. labels, paper or tools and that the rim of the wheel is clean, free from oil and grease and from damage which, apart from other considerations, might be harmful to the tyre or affect its form.
- b) Wheels should be rested on rubber or felt mats to prevent damage during assembly.
- c) The outer surface of the tube and the inner surface of the tyre should be dusted with French chalk, any excess being shaken off.
- d) Tyre and tube balance marks (paragraph 4.4) should be aligned during assembly.
- e) After fitting a tube into a tyre, the tube should be smoothed out with the hand to remove any creases; this will help to prevent the trapping of air inside the tyre during inflation.
- f) Care should be taken to ensure that valves of the correct part number are fitted. The inflation valves for all high pressure tyres should have hexagonal valve caps and should be fitted with cores having stainless steel springs.

4.6 **Well-base Wheels**

4.6.1 **Preparation for Fitting**

When fitting a tyre to this type of wheel, all air should be expelled from the tube before it is fitted into the tyre. This should be done by removing the core from the valve and rolling the tube tightly until it is completely deflated; the core should then be refitted.

4.6.2 **Fitting the Lower Bead**

The tyre should be inclined to the wheel and the lower bead pushed on by hand to just over half-way, ensuring that the bead enters the well. The fitting of the bead should be completed in a series of small 'bites' with the appropriate lever, using water or an approved bead lubricant to facilitate fitting.

4.6.3 The tube should be placed on top of the tyre so that the position of the valve stem corresponds to the valve hole in the wheel. The valve-bearing portion of the tube should then be pushed into the tyre, the valve inserted into the valve hole and loosely secured with the valve cap or extension piece. Finally, the remainder of the tube should be pushed into the tyre and, after ensuring it is clear of the bead seat, inflated gently until it adopts its correct contour, so that it can be checked for freedom from twisting or creasing. While it is inflated, the position of the valve should be checked to ensure that it is concentric with the hole.

4.6.4 **Fitting the Top Bead**

The top bead should be fitted with the appropriate lever, ensuring that the bead section adjacent to the valve is the last to be fitted and using a lubricant as before. Care must be taken to ensure that the bead enters the well without nipping the tube.

4.6.5 After the tyre has been fitted it should be inflated to a pressure sufficient to position the beads on the bead seats. The tube should then be slowly deflated, care being taken not to disturb the bead positions and slowly re-inflated and tested as outlined in paragraphs 7 and 8 respectively. The purpose of deflation is to ensure that the tube adopts a position free from creases and that the minimum amount of air is trapped between the tyre and tube.

4.7 **Divided Wheels**

4.7.1 **Preparation for Fitting**

The wheel should be dismantled by removing the nuts, collars, locking plates and bolts and then the upper half of the wheel should be lifted off.

4.7.2 **Fitting the Tyre**

The tube should be placed in the tyre and then inflated until it just adopts its correct contour. Great care is necessary when fitting tyres to this type of wheel, since if the tube is not sufficiently inflated it may become trapped between the two halves of the wheel; conversely, if the tube is over-inflated, the halves of the wheel will not meet. The tyre, with the tube inflated as described above, should be placed on the lower half of the wheel, with the valve in alignment with the valve hole.

4.7.3 The upper half of the wheel should then be fitted, two opposite bolts being inserted to guide it into position; care should be taken to ensure the valve is centrally positioned in its hole. On pressing the two halves of the wheel together, a metallic noise should be heard when they meet; this is a good indication of whether or not the tube has been nipped. When it is ensured that the tube is not trapped, the remaining bolts should be inserted and the nuts fitted, but not tightened at this stage since tightening may cause the wheel to turn in the tyre and so damage the valve stem.

- 4.7.4 The tyre should now be inflated to a pressure sufficient to position the beads on the bead seats and as soon as one bead grips the wheel, the bolts should be progressively tightened, taking opposite bolts in a sequence similar to that shown in Figure 3. The final tightening should be in the order and to the torque values recommended by the manufacturer.

NOTE: If the tyre has fitting lines on its walls just above the wheel rim, these should be used as a guide to the correct fitting of the tyre.

- 4.7.5 The nuts should then be locked, as appropriate and the tyre inflated and tested as outlined in paragraphs 7 and 8 respectively.

4.8 Detachable Flange Wheels

4.8.1 Preparation for Fitting

The lock-ring and loose flange should be removed from the wheel, the method of removing the lock-ring depending on the type fitted.

a) To remove the split type lock-ring, a screwdriver should be inserted in the slot and, after the flange has been pushed inward and clear of the lock-ring, the lock-ring should be gently prised from the groove. Lock-rings of the coil type can be removed with the fingers.

b) When the flange has been removed, the wheel should be laid flat on a block to allow the tyre to drop to the full depth of the wheel.

4.8.2 Fitting the Tyre

The tube should be placed inside the tyre and inflated to shape, after which the tyre should be positioned on the wheel, care being taken to ensure that the valve is correctly positioned in relation to the valve slot.

- 4.8.3 The loose flange should be placed in position and pushed down clear of the lock-ring groove in the wheel; the lock-ring should then be fitted. If the lock-ring is of the split type, care must be taken to ensure that the collar, if fitted, is correctly positioned in the notches in the wheel and the flange. Coil type lock-rings must be fitted by hand. Finally, the tyre should be inflated and tested as outlined in paragraphs 7 and 8 respectively.

5 Fitting Tubeless Tyres

5.1 General

Prior to fitting the tyre, the wheel should be examined for scratches and other damage in the flange, bead seat and rim areas. Any damage should be blended out within the limits permitted by the relevant Maintenance or Overhaul Manual. The beads and inner liner of the tyre should be checked for damage and the wheel sealing ring should be checked for defects such as deformation, permanent set and ageing. The precautions outlined in paragraph 4.5 should be observed, as applicable.

5.2 Fitting the Tyre

- 5.2.1 The seal spigot joint faces of divided wheels and seal register area, should be cleaned and lightly lubricated with a preparation recommended by the manufacturer. The seal should then be stretched evenly onto the wheel, ensuring that it is seating correctly in its location groove.

- 5.2.2 The tyre bead and wheel bead seat areas should normally be kept dry, but some manufacturers permit or recommend the use of a bead lubricant to facilitate mounting. The tyre should be positioned on the wheel with the balance mark on the

tyre in alignment with the balance marks (if any) on the wheel. When the wheel has no balance marks, the tyre balance mark should be aligned with the valve location.

NOTE: It is important that the tyre beads should not become contaminated with wheel grease.

- 5.2.3 With divided wheels, the bolt threads should be lightly lubricated with a grease recommended by the manufacturer and the bolts progressively tightened, in a sequence similar to that shown in Figure 3, to the recommended torque value. Wet assembly of the bolts may be specified by the manufacturer.

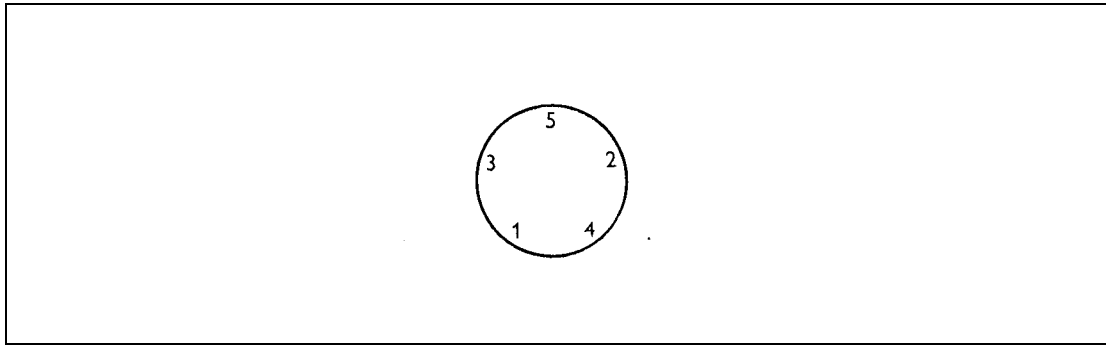

Figure 3 Tightening Sequence

- 5.2.4 With the valve core removed to permit the maximum flow of air, the tyre should be inflated as rapidly as possible to spread the tyre walls until the beads seat on the rim. Once this condition has been achieved, inflation should be discontinued immediately. If inflation cannot be effected, as a result of, for instance, tyre distortion caused by storage or transit, the assembly should be stood vertically and a load applied to the crown.
- 5.2.5 When the beads are correctly seated, the valve core should be refitted and the tyre should be inflated and pressure tested as outlined in paragraphs 7 and 8 respectively.

5.3 Sidewall Valves

Some tubeless tyres are fitted with a sidewall valve (Figure 4) which is in the form of a rubber self-sealing insert in the tyre wall. A central aperture in this insert permits the insertion of a servicing needle for inflation and deflation purposes. Before inflating a tyre of this type, the servicing needle must be inspected for cleanliness and lubricated with the felt pad contained in its sheath.

NOTE: Servicing needles should be inserted and removed using a twisting motion.

6 Wheels Suitable for Tubed or Tubeless Tyres

- 6.1 Detachable flange wheels are available to which either tubeless tyres or tubed tyres can be fitted. This is effected by means of special adaptors which permit an inflation valve assembly to be used for both purposes. For tubeless tyres the special adaptor is secured by a nut and washer and is made leakproof by a rubber 'O' ring clamped between the washer and the outer chamfered seating of the adaptor housing, as illustrated in Figure 5(A). For tubed tyres the adaptor is integral with the inner tube and is similarly secured by a nut and washer, but in this instance an additional rubber 'O' ring is fitted between the head of the adaptor and the inner chamfered seating of the adaptor housing, as shown in Figure 5(B).

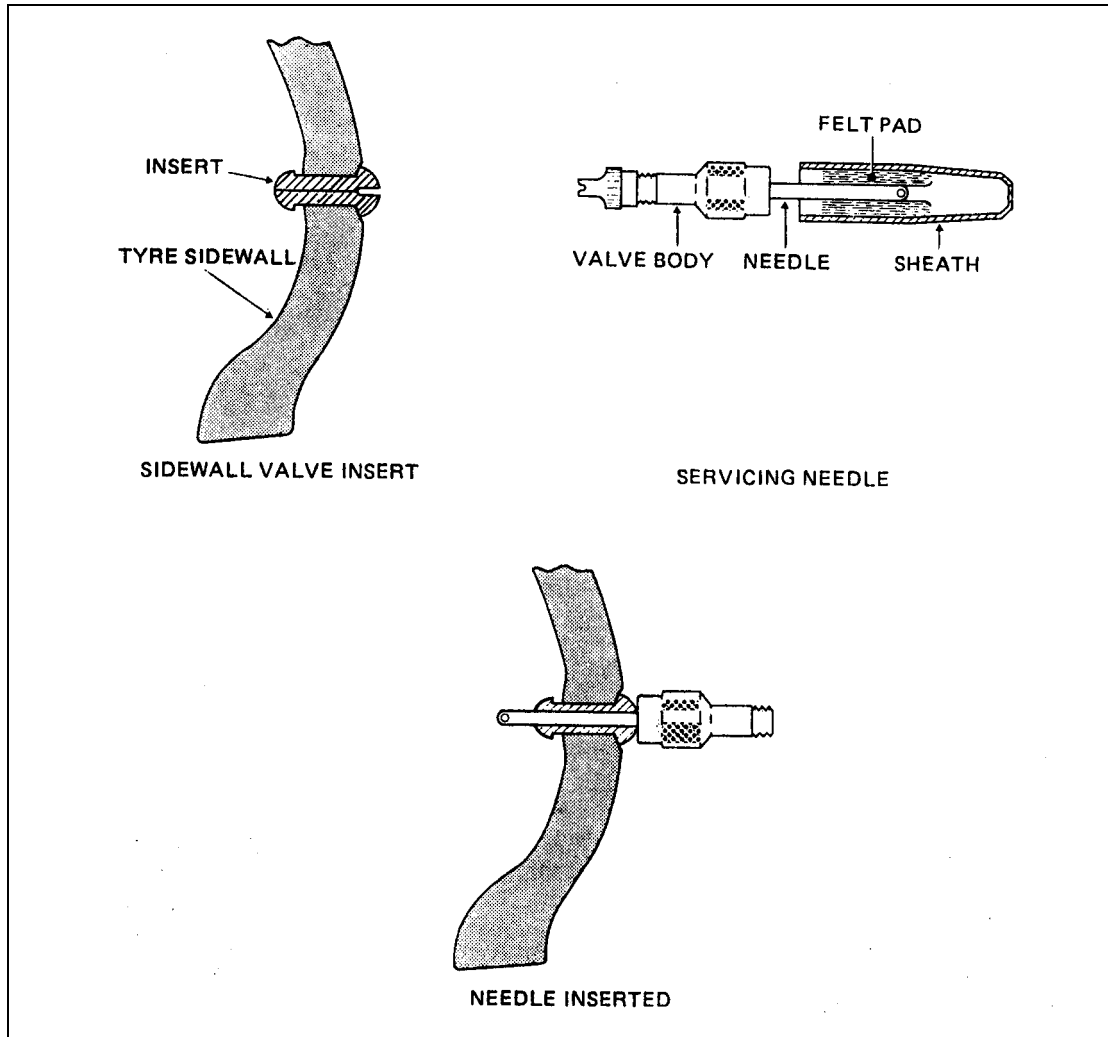

Figure 4 Sidewall Valve

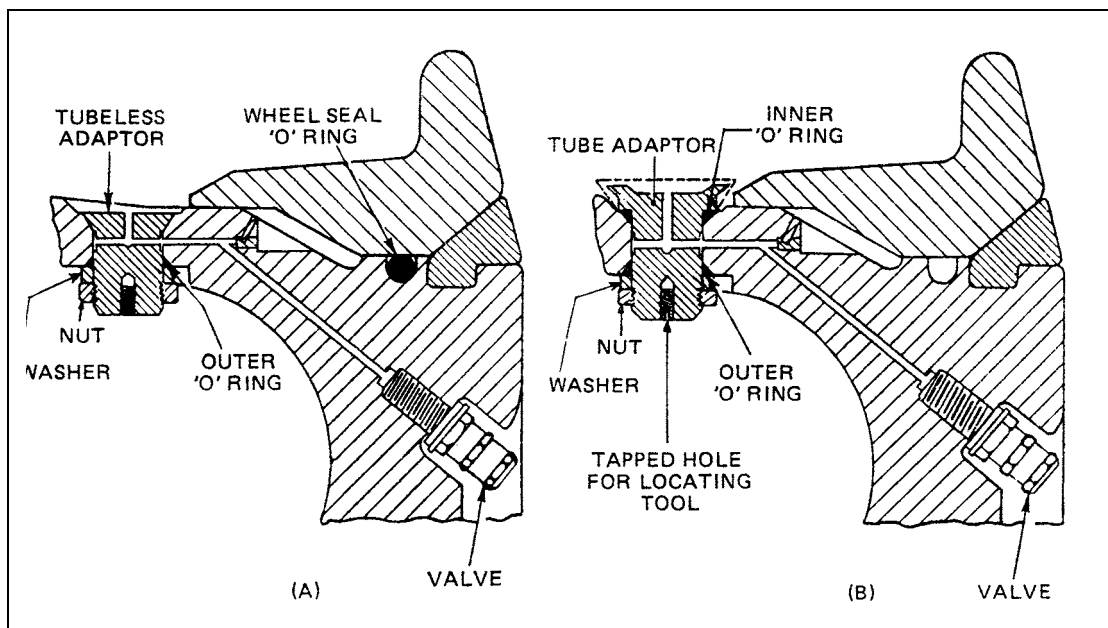

Figure 5 Adaptors For Combination Scheme

6.2 Fitting Tubeless Tyres

If the adaptor has been removed, ensure that its sealing face and also the sealing face of the wheel are not damaged or corroded. The adaptor should be placed in position and the outer 'O' ring should be lightly lubricated with an approved grease and carefully passed over the adaptor threads. The assembly should be secured to the wheel with the washer and nut and the adaptor should be wirelocked to its retaining nut. The tyre should be fitted as recommended in paragraph 5.2 and should be pressure tested as indicated in paragraph 8. If the duration pressure test (paragraph 8.3) is employed, the efficiency of the outer 'O' ring and the inflation valve seal should be checked by the local application of an acid-free soapy water solution (prepared with non-corrosive soap). After this test the solution must be washed off with clean water and the part thoroughly dried.

6.3 Fitting Tubed Tyres

6.3.1 The tube must be fully deflated (paragraph 4.5.1) before it is fitted into the tyre. The inner 'O' ring should be lightly lubricated with an approved grease and carefully passed over the adaptor threads until it seats around the shoulder adjacent to the tube.

6.3.2 The end of a special adaptor locating tool should be screwed into the end of the adaptor and the tyre should be placed on the wheel, aligning the adaptor with its housing.

6.3.3 The locating tool should be passed through the adaptor housing in the wheel and, after rechecking the alignment, the tyre should be fitted, ensuring that the adaptor remains located in its housing. Finally, the wheel should be assembled, but in this instance the 'O' ring between the loose flange and the wheel (Figure 5(B)) should not be fitted.

6.3.4 Assembling the Wheel

The wheel should be placed with the fixed flange upper-most and the adaptor should be pulled carefully into position. The outer 'O' ring should be greased and threaded over the locating tool, followed by the washer and nut, after which it should be passed carefully over the adaptor threads. The adaptor should be secured by finger-tightening the nut and the locating tool should be removed. The special retaining tool should be used to compress the inner 'O' ring, after which the adaptor nut should be fully tightened. The loose flange should then be fitted (paragraph 4.7.3).

6.3.5 Inflation and Testing

The tyre should be inflated (paragraph 7) and pressure tested (paragraph 8) and on completion of the test, the tightness of the adaptor nut should be rechecked, after which it should be wirelocked. The sealing efficiency of the outer 'O' ring should be checked by applying an acid-free soapy water solution over the crevices between the wheel, lock-ring and flange. The gap between the ends of the lock-rings should be blocked with rags or paper to prevent the solution draining into the wheel.

NOTE: This test on the inner 'O' ring should not be carried out until at least one hour after inflation in order to allow air trapped between the tyre and tube to escape first.

7 Inflation after Fitting

7.1 General

After fitting, both tubed and tubeless tyres should be inflated to the test pressure specified in the relevant manual.

- 7.2 A suitable supply of dry air or nitrogen should be connected to the valve; nitrogen is preferred (see CAP 747 Mandatory Requirements for Airworthiness Generic Requirement (GR) No. 16), but air may be used provided that the moisture content, measured in the expanded condition, is less than 0.02 g/m^3 . A screw-on type of connector should be used on tyres which are to be inflated to a pressure in excess of 700 kN/m^2 (100 lbf/in^2) and the tyre and wheel assembly should be contained within a safety cage to prevent injury to the operator.
- 7.3 All tyres should be inflated slowly and this is particularly important with tubed tyres. With tubed tyres, inflation to 140 kN/m^2 (20 lbf/in^2) should take at least two minutes and further inflation to full test pressure should take at least another four minutes. This procedure will reduce the possibility of trapping air between the tyre and tube.

8 Testing

- 8.1 The testing of either tubed or tubeless tyres should normally be by means of a duration pressure test, but an immersion test may sometimes be permitted on tubeless tyres when insufficient time is available. Pressure loss will occur on most tyres during a test, because of tyre stretch and will be most apparent during the first 12 hours; the figures quoted for the duration pressure test take account of this loss.

8.2 Venting

With a tubeless tyre, venting from the awl vents (paragraph 2.4) occurs in three stages. The first stage of venting results from residual air in the casing and may be fairly rapid, but virtually ceases after 20 minutes. The second stage is a slow seepage of residual air from the casing and may last for several hours. The third stage is a continuing process and results from normal permeation through the inner lining. Tubeless tyres should, therefore, be tested after the first stage of venting has ceased, or misleading results could be obtained.

8.3 Duration Pressure Test

This test should normally be carried out as follows:

- a) The valve cap should be removed and the valve checked for leakage.
- b) The actual tyre pressure should be checked and recorded.
- c) The assembly should be left for 12 hours and the pressure should again be checked and recorded.
- d) If the loss in pressure from that originally recorded exceeds 10% the assembly should be rejected. If the loss in pressure is less than 10% the tyre should be re-inflated to the original pressure.
- e) The assembly should be left for a further 12 hours and the pressure again checked and recorded.
- f) If the pressure loss is more than $2\frac{1}{2}\%$ the assembly should be rejected, but if less than $2\frac{1}{2}\%$ the assembly may be considered serviceable and returned to service.

NOTE: When recording tyre pressures allowance should be made for changes in ambient temperature. A temperature change of 3°C will result in approximately a 1% change in pressure. Application of the tyre pressure gauge will also result in a slight loss of pressure.

8.4 Immersion Test

After the first stage of venting, i.e. 20 minutes after inflation, the wheel and tyre should be mounted on a suitable bar and suspended in a tank of water so that the

water covers the lower cross-section of the tyre and valve, but does not reach the wheel bearings. The wheel should then be slowly rotated and checked for leakage from the bead seats, seal area, valve, fusible plugs (see CAAIP Leaflet 32-20) and wheel hub. A continuous stream of bubbles from any of these areas is cause for rejection. After testing, the wheel and tyre assembly should be thoroughly dried, using a jet of compressed air.

- 8.5 After tests have been satisfactorily carried out, the pressure should be reduced to 20% of unloaded inflation pressure for storage and transit and the valve cap should be refitted and tightened to the specified torque value.

9 Tyre Creep

- 9.1 When wheels are first fitted to an aircraft, the tyres tend to move slightly as they settle down on the rims, the initial movement varying according to load, pressure, braking, shimmy and outside diameter of the tyre in relation to rim diameter. After the settling down period, circumferential movement may continue gradually and, if this extends beyond a certain limit, the valve may be torn from the tube.
- 9.2 In order that creep may be detected, marks are moulded into the lower wall of most tyres. The marks usually consist of two arrows, spaced 25 mm (1 in) apart on tyres up to 600 mm (24 in) nominal outside diameter and 38 mm (1.5 in) apart for all larger tyres. The marks usually commence at the wheel rim and extend outward, the surface between being knurled.
- 9.3 The knurled surface should be painted white, the paint mark being carried down onto the rim. The width of this mark represents the maximum circumferential movement permitted with tubed tyres and if the tyre creep mark becomes out of alignment with the mark on the wheel by more than the width of the mark, the wheel should be removed and the tyre and tube taken off and reassembled; before reassembly, the valve should be checked to ensure that it is undamaged. In the case of tubeless tyres, creep is not considered to be detrimental provided that bead condition is satisfactory and any pressure loss is within limits.
- 9.4 When tyre replacements are made, the old marking on the wheel should be removed with a suitable solvent and a new creep mark applied.

10 Maintenance of Tyres

- 10.1 Unsatisfactory tyre maintenance can significantly affect tyre performance and reliability and jeopardise aircraft safety. Serious accidents and incidents have occurred when engine, airframe and aircraft systems have suffered damage as a result of neglected or incorrect tyre maintenance. Various studies indicate that a significant number of tyre failures and premature removals could have been prevented by careful attention to recommended tyre maintenance procedures and practices.

NOTE: Where removal of a tyre is recommended in this paragraph, it should be understood that this implies removal of the tyre and wheel assembly from the aircraft.

10.2 Tyre Pressures

- 10.2.1 The importance of keeping tyres inflated to the correct pressure cannot be overstated. Underinflated tyres may creep to such an extent that the valve could be torn out, causing the tyre to deflate rapidly, whilst over-inflation can cause excessive vibration when taxiing, uneven tyre wear and high pressure bursts. In addition, where two wheels and tyres are mounted on the same axle, unequal tyre pressures will

result in one tyre carrying a greater share of the load than the other, with possible operation above its rated capacity; the undercarriage may also be subject to additional stress.

10.2.2 Tyre manufacturers specify a rated inflation pressure for each tyre, which applies to a cold tyre not carrying any load. The pressure to which a tyre should be inflated when it is subject to aircraft weight, is determined by adding a pressure allowance (normally 4%) to the rated inflation pressure. A tolerance of 5% to 10% above the loaded inflation pressure is generally specified and tyre pressures up to this maximum are permitted and may benefit tyre reliability. The loaded inflation pressures for the tyres on a particular aircraft may be specified in the relevant Maintenance Manual as the maximum and minimum pressures permitted, or in the form of a graph with pressure being a function of aircraft weight.

10.2.3 After an aircraft has landed, or has been subject to prolonged taxiing, individual tyre pressures may vary because of the absorption of energy by the tyre and heat transfer from the brake units and a pressure rise of up to 10% can be expected. This pressure should not be reduced to normal working pressure as this could result in under-inflation at normal temperatures.

10.3 Inflation Procedures

10.3.1 Dry air or nitrogen should be used for inflating all tyres and the applicable precautions outlined in paragraph 7 should be observed. The particular gas specified by the aircraft manufacturer should always be used and should not be mixed with the alternative unless specifically authorised (see CAP 747 GR No. 16). If a dial-type gauge is used, the required inflation pressure should register in the centre of the dial; all gauges should be checked for accuracy at frequent intervals. When using a high pressure storage bottle, a pressure reducing valve must be incorporated in the delivery line.

10.3.2 The normal procedure for inflating a tyre is as follows:

- a) Check the pressure required by reference to the aircraft Maintenance Manual.
- b) Remove the valve cap and connect the supply to the valve (ensuring that a screw-on connector is used for pressures above 700 kN/m² (100 lbf/in²)).
- c) Adjust the regulator on the inflation trolley to the required pressure.
- d) Slowly inflate the tyre to the required pressure.
- e) Disconnect the supply, check the valve for leakage, then refit the valve cap.

10.3.3 Cold Tyres

When checking the pressure of tyres which are at ambient temperature, any tyre which is more than 10% below loaded inflation pressure should be rejected, together with the companion tyre on the same axle. Any tyre which is between 5% and 10% below loaded inflation pressure should be re-inflated to the correct pressure and checked at the next daily check; if the pressure is again more than 5% low the tyre should be rejected.

10.3.4 Hot Tyres

It may often be necessary to check the pressures of tyres which are still hot following a landing. The pressure of each tyre should be checked and noted and compared with the pressures of the other tyres on the same undercarriage leg. Any tyre with a pressure of 10% or more below the maximum recorded on the same leg should be re-inflated to that maximum pressure but should be rejected if a similar loss is apparent at the next check.

10.4 Examination of Fitted Tyres

10.4.1 A careful visual examination of tyres should be carried out prior to each flight, rotating the wheels wherever possible to ensure that the whole surface of the tyre is checked. Manufacturers prescribe limits of damage within which a tyre may be kept in service; tyres damaged in excess of these limits should be removed from the aircraft and repaired or scrapped as appropriate. The following paragraphs summarise the actions which should be carried out.

10.4.2 Embedded Stones, Flints and Glass

The outer surface of the tyre should be examined for embedded objects and any found should be carefully removed.

10.4.3 Cuts and Scores

All cuts should be probed with a suitable blunt tool in order to assess the depth and extent of any damage to the casing. Minor damage may be defined as that which does not affect the casing cord: cuts in both the tread and side rubber, providing they do not expose the casing cord, do not appreciably weaken the tyre. Such defects should be filled with a tyre dough compound, since continued exposure permits the entry of water and grit, which tends to cause chafing and rotting. Tyres damaged beyond the limits described above should be rejected.

10.4.4 Bulges

The presence of bulges may indicate a partial failure of the casing and the tyre should be removed for further examination. If it is obvious that the casing has failed, i.e. if the fabric is fractured, the tyre should be rejected, but if not it should be returned to the manufacturer for possible repair.

10.4.5 Wear

The extent to which tread has been removed from a tyre is not always easy to assess and may be either general or local; methods of indicating wear are shown in Figure 6. Local wear may be in the form of a 'flat spot' caused by severe abrasion or skid burns and these may occur as a result of excessive braking, hard touch-downs or aquaplaning. The probability of aquaplaning increases as the depth of tread is reduced. It is recommended that tyres be removed when wear has reached the limits defined below:

- a) Patterned tread tyres may be used until the tread is worn to the depth of the pattern.
- b) Ribbed tyres with marker tie bars may be used until worn to the top of the tie bars.
- c) Ribbed tyres without marker tie bars may be used until worn to within 2 mm (0.080 in) of the bottom of the wear indicator grooves.
- d) Twin contact tyres may be used until the centre of the crown shows sign of having been in contact with the ground.
- e) Plain tread tyres may be used until either the grey cushion rubber is exposed (on early tyres only), or when the shape of the casing cords can be seen through the cushion rubber.

NOTE: On tyres with reinforced tread, several layers of fabric are moulded into the tread rubber and will become visible during normal use; the threads so exposed should not be confused with the casing cords. These tyres are provided with marker tie bars which should be used to assess the wear as in b).

10.4.6 **Creep**

Tyre creep should be dealt with as indicated in paragraph 9.

10.4.7 **Sponginess**

Tyres which are only slightly affected by fuel, oil or glycol and which, after being wiped and allowed to dry, show no appreciable signs of swelling or softening, may be considered serviceable; tyres affected beyond this stage should be rejected.

10.4.8 **Flat Spots on Nylon Tyres**

Tyres having nylon casings may, due to their lack of elasticity, develop a temporary 'flat spot'. This should not be confused with the flat worn on the tread as described in paragraph 10.4.5 but is caused by the local relief of tension in the cords at that section of the tyre and is usually the result of the tyre being subjected to static load for a lengthy period.

- a) Stretch of the nylon cords is considerable and progressive and when the load is removed the cords do not immediately resume a tension equal to that of the cords in the rest of the casing.
- b) Normally the flat spot works itself out during the period of taxiing before take-off, but should this not be the case, the tyre will be out of balance and set up vibration in the aircraft during take-off.
- c) Precautions against the occurrence of flat spots can, however, be taken; these include occasionally moving aircraft which are to be stationary for lengthy periods in order to transfer the load to different sections of the tyres.
- d) If a flat spot has developed, it can normally be remedied by rolling or taxiing the aircraft for a short distance.

10.4.9 **Heat Transmission**

On aircraft main wheels, excessive braking may result in the transmission of heat to the beads of the tyres. If this is evident from indications of excessive heat on the wheels (such as discolouration, paint flaking or melting of fusible plugs) the tyres should be carefully examined. The results of overheating are indicated by 'tackiness' of the tyre bead and, in severe cases, a deposit from the tyre will adhere to the wheel flanges and bead seats. Tyres affected in this manner should be rejected.

10.4.10 **Deflated Tyres**

Tyres which have been under load while in a deflated condition should be removed from the aircraft. If the aircraft has taxied with a tyre in this condition, the deflated tyre and its axle companion should be scrapped, but if a single tyre deflates while static (except when deflated for servicing purposes) it should be removed and inspected in accordance with the relevant Maintenance Manual. If more than one of the tyres on a multi-wheel undercarriage are found to have been run in a deflated condition, all the tyres on that undercarriage should be scrapped.

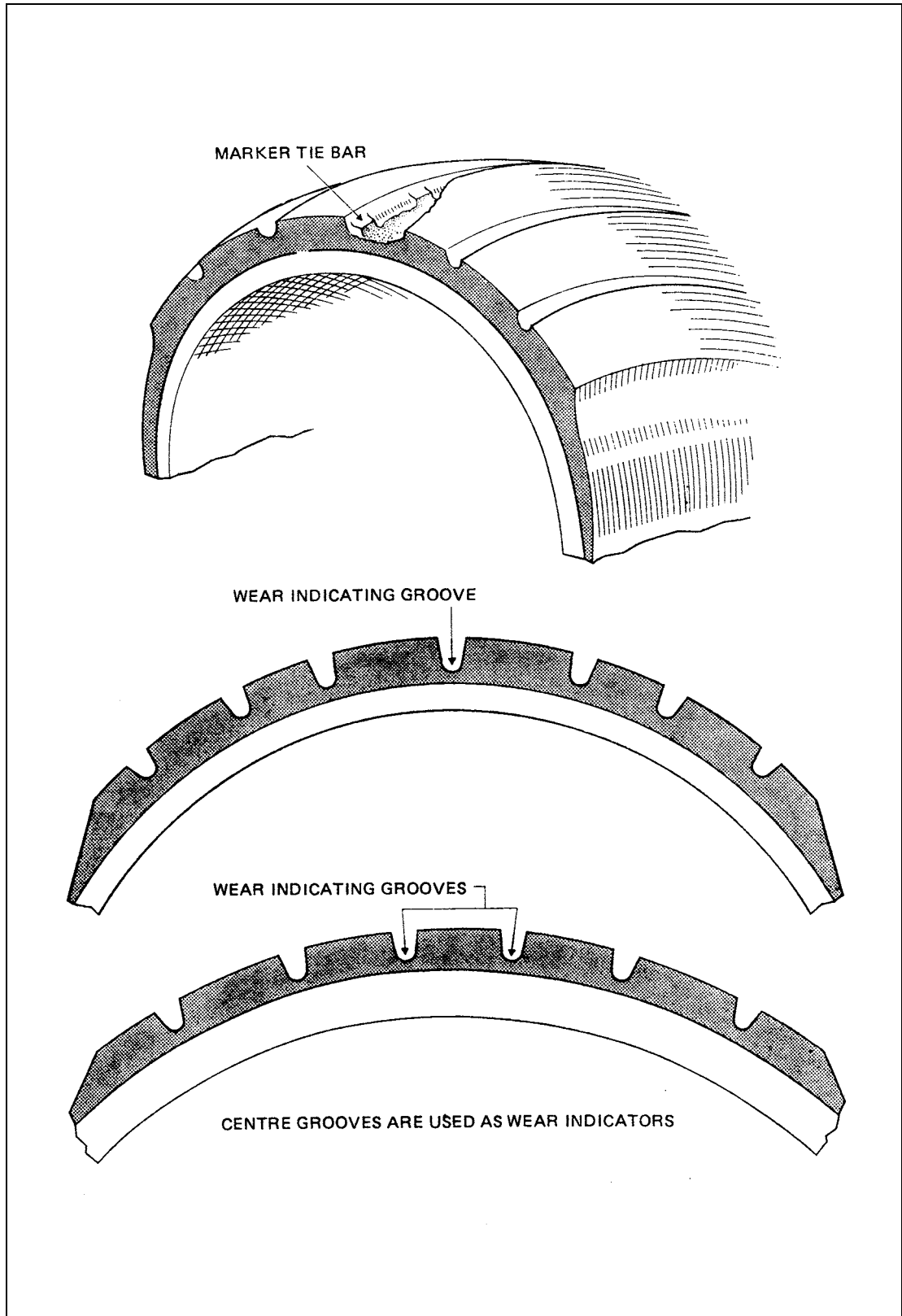

Figure 6 Indication of Tyre Wear

10.4.11 Rejected Take-offs

A rejected take-off at high energy levels may have resulted in the overstressing or overheating of all the main wheel tyres, although no evidence of damage may be visible. Reference should be made to the relevant Maintenance Manual for guidance on the action to be taken.

10.4.12 Replacement Tyres

New and retreaded tyres have slight differences in external diameters and replacement tyre and wheel assemblies for twin or multi-wheel undercarriages should be selectively fitted to ensure that both or all tyres take an equal share of the load.

10.5 Protection

Tyres must be protected from excessive heat, dampness and bright light and from fluids such as oil, fuel, glycol and hydraulic fluid, since all of these have a harmful effect on the rubber. If the aircraft is to be parked for any length of time, or if any of the above-mentioned systems are to be drained, an oilskin cover should be placed over the tyre. Any fluid inadvertently spilt or allowed to drip onto the tyre should be wiped off immediately.

11 Removing Tyres

11.1 Defects in tyres, particularly those which would be difficult to find once the air pressure is released, should be marked with wax crayon before the tyre is removed. It is recommended that the tyre pressure should always be reduced before removing a wheel from an aircraft and that a screw-on type deflator is used to deflate a tyre or tube.

11.2 Tubed Tyres

11.2.1 Well-base Wheels

- a) The tube should be deflated and the valve core removed; the bead should then be unseated by levering it away from the rim of the wheel on the valve side.
- b) The valve should be pushed in and tucked away under the tyre, the bead being levered off by commencing at approximately 60° from the valve and working away from it, using levers lubricated with acid-free soapy water.
- c) The wheel should be turned over and the other bead unseated as in a). Some difficulty may be experienced in levering the bead from the rim on this side of the wheel, owing to the heat generated by the brakes. In this instance also, the levers should be lubricated with acid-free soapy water.
- d) The tube should be removed by grasping it diametrically opposite the valve and pulling it out of the tyre, the valve being the last part of the tube to emerge.
- e) The bead should be pressed into the well of the wheel and a lever placed between the bead and the wheel flange with its tip positioned at the valve hole. When pressure is applied to the lever, the tyre should come off quite easily.

11.2.2 Divided Wheels

Great care must be taken to ensure that the tyre is completely deflated before any attempt is made to remove the loose members (see also paragraph 11.4).

- a) The tube should be deflated and the valve core removed; the bead opposite to the valve should be unseated by levering it away from the wheel rim, using acid-free soapy water as a lubricant.
- b) The second bead should be unseated in a manner similar to that used for the first bead and the bolts should be removed from the wheel.
- c) An aligning mark, to assist reassembly, should be placed on both halves of the wheel below the valve, after which the upper half of the wheel should be lifted off and the tyre removed.
- d) If a tyre is not to be fitted to the wheel immediately, the wheel should be reassembled.

11.2.3 Detachable Flange Wheels

Great care must be taken to ensure that the tyres are completely deflated before any attempt is made to remove the loose members. (See also paragraph 11.4).

- a) The tube should be deflated and the valve core and flange locking device removed; the detachable flange may then be levered away from the tyre bead. The wheel should be turned over and the second bead loosened, after which the tyre and tube should be removed from the hub, care being taken to ensure the tube valve is not damaged in the process.
- b) If a tyre is not to be fitted to the wheel immediately, the wheel should be reassembled.

11.2.4 Wheels Embodying Combination Adaptor Scheme

Deflate the tyre by removing the valve cap and core, but before attempting to remove the flange and locking device, remove the adaptor nut, washer and outer 'O' ring. The adaptor should be pushed well into the tyre with a blunt wooden probe to avoid the possibility of damage to the adaptor during dismantling. The wheel and tyre assembly may then be dismantled as outlined in paragraph 11.2.3.

11.3 Tubeless Tyres

The tyre should be deflated and the valve core removed, or, where a sidewall valve is used, deflated by removing the core from the servicing needle and inserting the needle in the valve insert. The valve core and cap should be refitted or the servicing needle removed as appropriate. The beads should be unseated from the taper bead seat by means of a special tyre removal machine which exerts an even pressure circumferentially round the wheel on both sides of the tyre. Sharp tools or tyre levers must not be used to unseat the beads as this may impair the sealing properties of the tyre and wheel. Finally, the wheel assembly should be dismantled according to its type and the rubber sealing rings removed.

11.4 High Pressure Tyres

During deflation of these tyres the valve stem may become blocked with pieces of ice. The use of probing devices to remove the ice is unnecessary, since the ice formation will break down under normal ambient temperatures, permitting the further passage of air. However, it must be noted that blockage of the valve by ice may take place several times during deflation and it is essential to allow sufficient time to elapse between the removal of the valve core and the commencement of dismantling to ensure that the air has been completely exhausted.

12 Inspection of Tyres and Tubes Removed from Aircraft

12.1 Paragraph 10 details the checks to be made on tyres during running maintenance; at the periods specified in the Maintenance Schedule, the tyres should be removed from the aircraft and examined as described in the manufacturer's Service Manual. Guidance on inspections and typical defects is given in this paragraph.

12.2 Tyres

12.2.1 Fractures

The inside of the tyre should be examined for fractures caused by fatigue or concussion. The latter defect may be caused by heavy impact on a protrusion, e.g. striking a stone during touch-down. External detection of the fracture may be difficult, but a dark stain on the tyre, or a very slight smooth bulge, may be visible where the rubber is bruised.

- a) If a fracture has occurred, internal inspection will reveal a diagonal line or a 'star', dark in colour, at the point where the impact occurred.
- b) The interior examination of a large tyre may be facilitated by rolling it along the floor and observing closely the area which is flattened by contact with the ground, since this tends to open the fracture.
- c) Tyres so damaged should be scrapped and labelled accordingly.

12.2.2 Bead Failure

Tyres showing any signs of bead chafing or break-up of the bead should be returned to the manufacturer for assessment of possible repair.

12.3 Tubes

12.3.1 The base of the tube, i.e. that part of the tube which has been in contact with the tyre, on the brake side, should be examined for evidence of thinning of the rubber caused by heat generated during normal braking operations.

12.3.2 Tubes which have thinned at the base, are perished or cracked, have 'grown' or stretched unduly, or show bad creases, must be discarded.

12.3.3 Valve stems should be examined for bending, cracks or damaged threads and if damaged beyond local repair, the tube should be rejected. Valve cores with bent pins or damaged threads, or showing signs of corrosion, should be renewed.

12.3.4 Cuts in tubes may be repaired by a vulcanising process, except where they occur in the region of the valve. Vulcanising is a specialised process and should only be done by trained personnel using suitable equipment.

12.4 Tubeless Tyres

The tyre should be thoroughly cleaned with clean water and inspected for damage, paying particular attention to the inner lining and the entire bead area. It is essential that the beads should be clean and free from grease.

13 Repair of Tyres and Tubes

13.1 Tyres and tubes which have been removed from aircraft because of damage which is considered to be in excess of the limits defined in paragraph 10, may still be repairable locally provided the necessary tools and vulcanising equipment are available. These repairs must not exceed the limits laid down in the manufacturers' Repair Manual and must be carried out by personnel having the specialised knowledge and experience

necessary and using only those materials specified by the manufacturer. The method of repair is to remove the damaged rubber and replace it with unvulcanised sheet rubber repair compound which is then vulcanised to the existing rubber by heat and pressure. During the vulcanising process the repair compound is converted into a material with properties almost identical to the surrounding rubber. A typical procedure for carrying out a repair is summarised in the following paragraphs.

13.2 **Classification of Damage**

The tyre or tube should be carefully inspected and all damage marked. A probe should be used to ascertain the depth and extent of cuts.

- 13.2.1 Minor damage to tyres is damage to tread or sidewall rubber not affecting the casing cords, up to a maximum of 38 mm (1.5 in) diameter. Numerous repairs of minor damage may be carried out.
- 13.2.2 Damage involving cut cords may be repaired in the tread area only, provided that not more than 20% of the cord layers or a total of four are damaged.
- 13.2.3 Small holes in tubes may be plugged with compound and larger damaged areas may be repaired up to an area of 50 mm x 50 mm (2 in x 2 in). Both types of repair must be vulcanised.
- 13.2.4 Tyres or tubes which are damaged beyond these limits should be returned to the manufacturer for possible repair.

13.3 **Repairs to Tyres**

- 13.3.1 For all types of repair, the tyre should be mounted on a wheel and inflated to a pressure of 140 to 210 kN/m² (20 to 30 lbf/in²) for crown and shoulder repairs, 70 to 140 kN/m² (10 to 20 lbf/in²) for sidewall repairs. A chalk line should be drawn round the damaged area to indicate the extent to which the rubber is to be removed.
- 13.3.2 The rubber is removed within the chalk circle by using a hollow drill, rotary rasp or knife as appropriate to the area affected, bevelling the edges at 45° and taking care not to damage the cords.
- 13.3.3 Where cords are damaged, the gap between the cord ends should be treated with tyre repair solution and filled with a suitable piece of tyre repair compound well rolled down.
- 13.3.4 The walls of the cavity and surrounding rubber should now be roughened with a rotary wire brush and the rubber remaining on the cord surface removed to expose the cords. The roughened rubber surface and exposed cords should now be given two coats of the tyre repair solution, the first coat being brushed well in and allowed to become tacky before lightly applying the second coat.
- 13.3.5 The repair area should now be built up with successive layers of tyre repair compound, each layer being well rolled down to exclude any air bubbles. When the level of the repair is slightly higher than the surrounding rubber, the surplus compound should be removed with a sharp knife (lubricated with water as necessary), leaving a slightly raised crown in the centre. The surface should then be cleaned, dried and dusted lightly with French chalk.
- 13.3.6 The pre-heated vulcanising unit, fitted with a suitably-shaped base plate, should now be clamped centrally over the repair and left in position for a period of time appropriate to the thickness of the repair as specified by the manufacturer. The temperature is controlled automatically at approximately 150°C (300°F).
- 13.3.7 After removal of the vulcanising unit, the repair should be tested by probing with a blunt pencil point; if the pencil springs back the repair is correctly vulcanised, but if an

indentation is left in the rubber the vulcanising unit should be replaced for a further 15 minutes.

- 13.3.8 The final stage of repair is the replacement of the tread pattern, which should be re-cut using either a hollow drill or knife.

13.4 Repairs to Tubes

13.4.1 Solution

The solution used for repairing tubes is prepared by cutting thin strips of tube repair compound, covering them with the solvent specified by the manufacturer and leaving them for 24 hours in a sealed container. The liquid thus obtained is then stirred and thinned down with solvent to the consistency of thin paint. Only small quantities of solution should be prepared as it is highly volatile and deteriorates quickly.

13.4.2 Small Holes

The hole should be roughened right through and the adjacent area cleaned with solvent and treated with solution. The plug should be made from a strip of tube repair compound, fed through the hole and trimmed off slightly proud of the surrounding material. The repair is completed by rolling down the plug and vulcanising for a period of time specified by the manufacturer.

13.4.3 Large Holes

A circular hole should be cut round the damaged area using a pair of curved scissors. Holding the scissors flat against the tube and working in a clockwise direction will ensure that the edge of the hole is correctly bevelled. The edges of the hole and surrounding area should now be roughened with a wire brush and cleaned with a muslin cloth dipped in solvent.

- 13.4.4 To prevent the repair from sticking to the opposite wall of the tube, a thin piece of paper, slightly larger than the hole, should be inserted through the hole and located centrally. The solution should then be applied on top of the paper and the roughened tube area and rubbed well in. When the solution has reached a dry, tacky, state the repair should be built up and vulcanised in the same manner as described for tyres in paragraphs 13.3.5 and 13.3.6, but using a flat base plate on the vulcanising unit and working on a suitable flat bench.

14 Remoulding Tyres

- 14.1 Most aircraft tyres, when worn beyond safe, usable limits, may have their useful life extended by replacement of the tread rubber; this operation may, however, only be carried out by the original manufacturer or by an approved specialist organisation. The term 'retread' is normally used where the crown and shoulder rubber is replaced and cured in a specially designed mould. The term 'remould' is normally used where the tyre is similarly processed, but is cured in a mould similar to that in which the tyre was originally made; the new tread is therefore cured and the sidewall rubber re-cured without being renewed. Tests have shown that the strength of a tyre casing does not deteriorate appreciably throughout its life; up to 10 remoulds have been carried out on specific tyres with only a 1% decrease in strength. The casing life for almost all aircraft tyres is therefore determined by initial tyre quality and the exercise of proper maintenance practices while the tyre is in service. One exception to the general rule is the case of the high performance aircraft where skin friction temperatures in continuous high-speed flight could result in prolonged high wheel-bay temperatures and consequently a diminished tyre life.

14.2 On new aircraft types the first few tyres are returned after service for a thorough examination by the manufacturer. If this examination is satisfactory the next few tyres are used to develop a remoulding technique and to evaluate the tyre's structural life. On successful completion of these tests the tyre is approved for one remould life. From this stage the process is repeated until a particular type of tyre can be released for its optimum number of remoulds.

14.3 **Initial Inspection**

The initial inspection of a tyre received by a manufacturer for repair or remould is carried out by personnel with a wide experience in the manufacture and servicing of tyres. The degree of damage which can be allowed depends on the use for which the tyre was designed and the aircraft type to which it is to be fitted. The inspector must take account of every type of deterioration to which the tyre has been subjected throughout its service life. Even though individual damage may be repairable, the general condition of a tyre often results in its rejection. The various types of damage which can occur are cracking, skin burns, oil contamination, excessive wear, tread separation, cuts, ply separation and damaged cords. The most highly stressed portion of the tyre is the bead area where only very minor damage is permitted.

14.4 **Buffing**

Depending on the extent of remoulding approved for a particular tyre the required amount of rubber is removed on a buffing machine. This operation also provides the opportunity for a further inspection of the tyre, as many defects such as cuts and broken cords, can only be seen when the tread is removed.

14.5 **Remoulding Process**

After the original rubber is removed, the casing is treated with a layer of cement and the complete new tread carefully rolled on under pressure. The whole assembly is then mounted in the appropriate mould, where heat and pressure are applied until vulcanising is complete. The vulcanising time and temperature are pre-determined by the manufacturer for the type, size and ply rating of the tyre.

14.6 When the remoulding process has been completed the tyre is balanced and re-inspected before being finally released for further service.

15 **Storage**

15.1 Excessive light and heat will cause cracking and general deterioration of rubber, therefore tyres and tubes should be stored in a darkened room having a dry temperature of from 10 to 27°C (50 to 80°F) and should be kept away from radiators, steam pipes, electric motors or other sources of heat. It should be ascertained that the possibility of contamination from oil or grease does not exist, since this would also cause rapid deterioration of the rubber.

15.2 **Tyres**

15.2.1 Preferably, tyres should be stored vertically in special racks embodying support tubes, so that each tyre is supported at two points. Two-thirds of the tyre should be above the support tubes and one-third below. By this method, the weight of the tyre is taken by the tread and distortion is reduced to a minimum. The tyres should be turned to a new position every two or three months.

15.2.2 Where space does not permit the use of the above method, tubed tyres may be stored horizontally in stacks on a level floor. The height of stacks should be limited to four tyres so that the weight does not cause distortion of sidewalls and tread on the

lower tyres which could lead to failure in service. Staggering the tyres in piles tends to distort the bead wires and casing. If possible a stack of tyres should be graded so that the largest tyre is at the bottom and the smallest at the top. This method of storing should not be used for tubeless tyres, as the beads could be pressed close together and make mounting and inflation more difficult.

15.2.3 Where tyres are delivered in bituminised hessian wrappers, the wrappers should be left on during storage.

15.3 **Tubes**

Tubes should preferably be stored in their original wrapping; if they cannot be stored in this manner they should be slightly inflated and stored inside tyres of appropriate size.

15.4 **Assembled Wheels**

The tyres on assembled wheels not required for immediate use should be inflated to a pressure of 140 to 210 kN/m² (20 to 30 lbf/in²) for storage and shipment.

15.5 **Shelf Life**

Provided that the ideal storage conditions are maintained, tyres and tubes may be kept in storage for up to seven years from the date of manufacture, without deterioration. It is recommended, however, that stocks be limited to a quantity which will ensure that a storage life of four years is not exceeded. This will ensure that the most advantage is taken of improvements in design and manufacturing techniques. After seven years in storage, tyres should be returned to the manufacturer for assessment.

16 **Records**

When required by the Maintenance Schedule, a record should be kept of the number of landings for each tyre on the aircraft.

INTENTIONALLY LEFT BLANK

Leaflet 32-20 Wheels and Brakes

1 Introduction

This Leaflet provides guidance and advice on the installation and maintenance of aircraft wheels and brakes. It should be read in conjunction with the relevant approved Maintenance and Overhaul Manuals and Maintenance Schedule, from which details of the manufacture and maintenance requirements of the particular components may be obtained. Information on flexible pipes is contained in Leaflet 20-50, on rigid pipes in Leaflet 20-60 and on tyres in Leaflet 32-10.

2 General

- 2.1 Aircraft wheels and wheel brakes are often subjected to severe conditions of operation including, shock loading and exposure to high temperatures. Therefore, the utmost care is necessary during installation and maintenance to ensure that their condition remains satisfactory during service.
- 2.2 Because of the risk of explosion caused by heat generated by friction in the brakes during landing and taxiing, special safety precautions may be necessary when handling or servicing brake, wheel and tyre assemblies, particularly in an extreme situation such as immediately after an abandoned take-off, when the components may be overheated.
- 2.3 On light aircraft, where aircraft weight and landing speed are low, single wheels are fitted at all landing gear positions. Wheel brakes on older types of aircraft are often of the expanding shoe type, similar to conventional automobile practice. These may be operated by cables or by a simple independent hydraulic system. A single hand brake lever may be used to apply both brakes together, or each brake may be operated individually from a pedal attached to the rudder bar. Modern high performance light aircraft are usually fitted with hydraulically operated disc brakes.
- 2.4 With larger and modern types of aircraft, where aircraft weight and landing speed are high and aerodynamic drag is low, multiple wheels are generally used at all undercarriage positions, to spread the aircraft weight over a greater area and facilitate stowage in the airframe structure. Some older types of medium sized aircraft are fitted with large single wheels and pneumatically actuated drum brakes, but most modern transport aircraft are fitted with twin nose wheels and twin wheels or a four-wheel bogie arrangement at each main undercarriage position. Brakes are of the multiple disc type and are operated from the normal aircraft hydraulic system.

3 Wheels

3.1 Manufacture

- 3.1.1 Wheels are usually made from aluminium or magnesium alloy forgings or castings and are of three main types (Figure 1), known as well-base, detachable flange and split hub. Well-base wheels are only fitted on light aircraft and are normally used in conjunction with tubed tyres. Nose wheels which do not house brake units, are usually of simpler manufacture than main wheels, but in some instances all wheels on an aircraft are interchangeable for ease of provisioning.

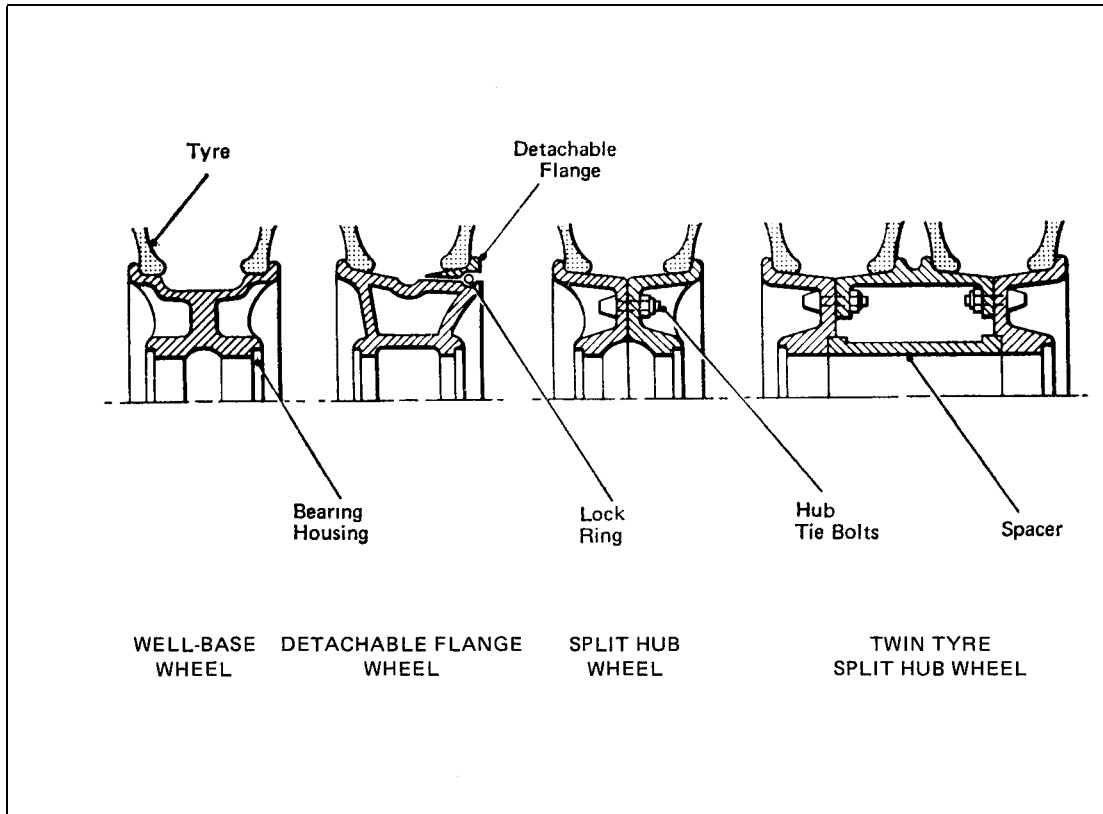

Figure 1 Wheel Types

- 3.1.2 Heat generated by braking action is dissipated by radiation and conduction through the wheel and tyre and every effort is made to keep heat transference to a minimum. Wheels are designed to permit optimum ventilation and cylindrical stainless steel heat shields may be installed around the brake unit. On some aircraft, an electric motor mounted within the axle, or a series of motors installed in the brake housing, drive fans which provide a forced draught through the wheel and relieve the build-up of heat.
- 3.1.3 To prevent the danger of tyre explosion, the main wheels of many modern aircraft are fitted with fusible plugs which melt at a predetermined temperature (approximately 150°C), allowing a piston to be blown out of the plug bore and thus deflating the tyre.
- 3.1.4 Some aircraft wheels are also fitted with a pressure relief valve, the purpose of which is to prevent over-inflation of the tyre.
- 3.1.5 In general wheels are mounted on ball or roller bearings which fit directly onto the axle, or onto a bearing sleeve which is keyed to the axle. In some cases, nose wheels are mounted rigidly onto a 'live' axle, which itself rotates within bearings in the nose wheel leg.

3.2 Removal

- 3.2.1 Before removing a wheel, the aircraft must be prepared and jacked up in accordance with the approved Maintenance Manual. These preparations may be very simple, such as chocking the opposite wheels and lifting the wheel which is to be removed by means of a bottle jack. On large transport aircraft additional procedures, such as fitting ground locks to the landing gear, landing gear doors and steering mechanism, may be necessary. In some cases one wheel of a twin wheel arrangement may be lifted clear of the ground by running the other wheel up an inclined block. On aircraft

with multi-disc brakes it is usual to set the brakes on before removing the wheel in order to keep the rotating discs in alignment with the driving keys in the wheel hub; on aircraft with drum brakes, however, application of the brakes would prevent removal of the wheel and they should be released.

3.2.2 A typical removal procedure is described below:

- a) Prepare aircraft for jacking in accordance with the appropriate aircraft Maintenance Manual.
- b) Raise axle or bogie, as appropriate, until the tyre is clear of the ground.
- c) Deflate tyre or reduce pressure to a low value.

NOTE: During release of tyre pressure, icing of the valve may occur and give a false indication of complete deflation. Sufficient time must elapse after the air flow has ceased to ensure that any ice has melted and that the tyre is sufficiently deflated.

- d) Where applicable, remove cooling fan or hub cap assembly.
- e) Remove axle nut locking device.
- f) Remove axle nut and install thread protector.
- g) Position wheel trolley and remove wheel carefully so as not to damage the axle.

NOTE: On some aircraft it is recommended that an approved extractor is used when removing the wheel.

- h) Remove grease seals and bearings.
- i) Install axle protector.
- j) Fit protective cover over the brake assembly if the wheel is not to be re-fitted immediately.

3.3 Installation

3.3.1 Before installing a wheel and tyre, the general condition of the wheel, tyre and bearings should be checked (paragraph 3.4 and Leaflet 32-10). The axle should also be checked for corrosion, scores and other damage, particularly in the bearing support area and, if an axle sleeve is fitted, this should be checked for allowable wear at the bearing area and correct fit on the axle. Bearings on new or replacement wheels may be packed with storage grease and this should be cleaned out and replaced by grease specified for service use.

3.3.2 A typical installation procedure is described below:

- a) Grease inner bearing and seal with the specified grease and install on axle.
- b) Slide wheel into position on axle, using the appropriate aligning fixture as necessary to line up the brake disc driving keys in the wheel hub with the slots in the rotating discs.
- c) Grease and install the outer bearing and seal.
- d) Remove thread protector and lubricate axle threads.
- e) Install axle nut and tighten to the recommended initial torque, rotating the wheel as the nut is tightened.
- f) Slacken axle nut then, again rotating the wheel, tighten to the specified final torque and fit the locking device.
- g) Replace cooling fan or hub cap assembly.

- h) Check tyre pressure and tyre growth clearance, retracting landing gear where necessary to facilitate this check, then lower the aircraft and remove the ground locks installed to prevent operation of the steering mechanism or landing gear doors.

3.4 **Maintenance**

3.4.1 **General**

A superficial inspection and minor repairs may be carried out with the wheel installed on the aircraft. A more detailed inspection is made when the wheel is removed for tyre replacement following operation with a deflated tyre (or with the companion tyre deflated on a twin wheel arrangement) and at the intervals specified in the approved Maintenance Schedule. Some wheels may require overhaul after a specified number of landings.

3.4.2 **Installed Wheels**

- a) The wheel should be examined for cracks, corrosion, distortion, dents and scores, particular attention being given to the wheel flanges. Small dents on the outside of the flanges may usually be blended within specified limits, but in general no damage is permissible where the flange is in contact with the tyre. When a dent or abrasion is blended out, the exposed metal should be closely inspected for cracks and the protective treatment renewed. It is particularly important to give prompt attention to protective treatments following repairs to magnesium alloy wheels.
- b) Wheel hub tie bolts and nuts, inflation valves, balance weights and, where visible, the axle nut locking device, should be inspected for security and damage. If any tie bolt is found defective, the wheel should be removed and the complete set renewed.
- c) The wheel, brake and tyre should be examined for signs of overheating, such as blistered or discoloured paint, distortion and leakage of grease from the wheel bearings.

NOTE: If a fusible plug is found to be blown out, the tyre should be scrapped and all fusible plug seals renewed, but the wheel may be satisfactory subject to certain checks (paragraph 3.4.3).

- d) Periodically the wheels should be raised clear of the ground in order to check for free rotation and end float in the bearings.

3.4.3 **Wheels Removed from Aircraft**

- a) The tyre must be completely deflated before any attempt is made to dismantle or remove a wheel or tyre.
- b) Dismantled wheels should be thoroughly cleaned in a suitable cleaning fluid and then examined for cracks, corrosion, distortion or other damage.
- c) Some manufacturers require that paint should be completely removed from wheels before checking for cracks. Where chemical paint strippers are used it is essential that the chemical is removed by thorough washing.
- d) A careful examination should be made for cracks around bolt holes, in the radius at the base of the wheel flange (tyre bead seat) and at other highly stressed points or changes of section. These examinations are normally made using ultrasonic or eddy current methods.

- e) Light surface corrosion can be cleaned off and damage blended out within specified limits, but deep corrosion, scores, dents or cracks beyond these limits will render the wheel unserviceable.
- f) Brake drums should be examined for signs of distortion, wear, scores and cracking and there should be no evidence of drum movement relative to the wheel. With disc type brakes the drive blocks in which the discs are tenoned should be checked for security, damage, wear and hammering.

NOTE: The braking surface of bi-metal brake drums is subject to crazing; this condition is acceptable until it advances beyond the limits specified in the relevant manual.

- g) Wheels should also be inspected for distortion and concentricity, by mounting the wheel on a mandrel in vee-blocks and checking at the flange with a dial test indicator. Distortion may also be checked using large calipers. After this check the wheel should be statically balanced.
- h) Wheels which may have been damaged by overheating but which are not found to be distorted and are otherwise serviceable, may be required to be given a check for material hardness. When this check is specified, the method and the acceptable range of hardness numbers will be found in the approved Maintenance Manual.
- i) Bearings may sometimes be inspected in position, but they must often be removed (using an extractor where necessary) in order that they may be thoroughly cleaned and inspected. They should be cleaned in a solvent such as white spirit and examined for corrosion, brinelling of the races, chipped balls or rollers, retaining cage condition, roughness and discolouration. If serviceable, bearings should be packed with approved grease immediately after inspection and protected from dust and dirt.
- j) Tie bolts, i.e. those used for clamping the two halves of a split hub, should be checked for corrosion, distortion, cracks and condition of threads. Any damage found on these bolts will necessitate their replacement. In some instances, self-locking nuts which are found to have a satisfactory locking torque may be re-used, but the manufacturer may require all stiffnuts to be discarded after disassembly.
- k) Wheels should be painted and reassembled in accordance with the manufacturer's recommendations and particular care should be paid to the sequence of assembly and torque tightening of the tie bolts. It is usually recommended that new seals should be fitted during re-assembly.
- l) When a tyre is assembled on a wheel, the complete unit should be statically balanced.

4 Drum Brakes

4.1 General

Although used extensively on earlier aircraft, drum brakes have largely been superseded by hydraulically operated disc brakes, on most modern high performance aircraft. Pneumatically operated drum brakes may still be found in service, however and the manufacture, operation and maintenance of a typical brake unit of this type is described in the following paragraphs.

4.2 Manufacture

- 4.2.1 The main components of the brake unit are the back plate, brake drum, expander tube (pressure bag) and brake linings (Figure 2).

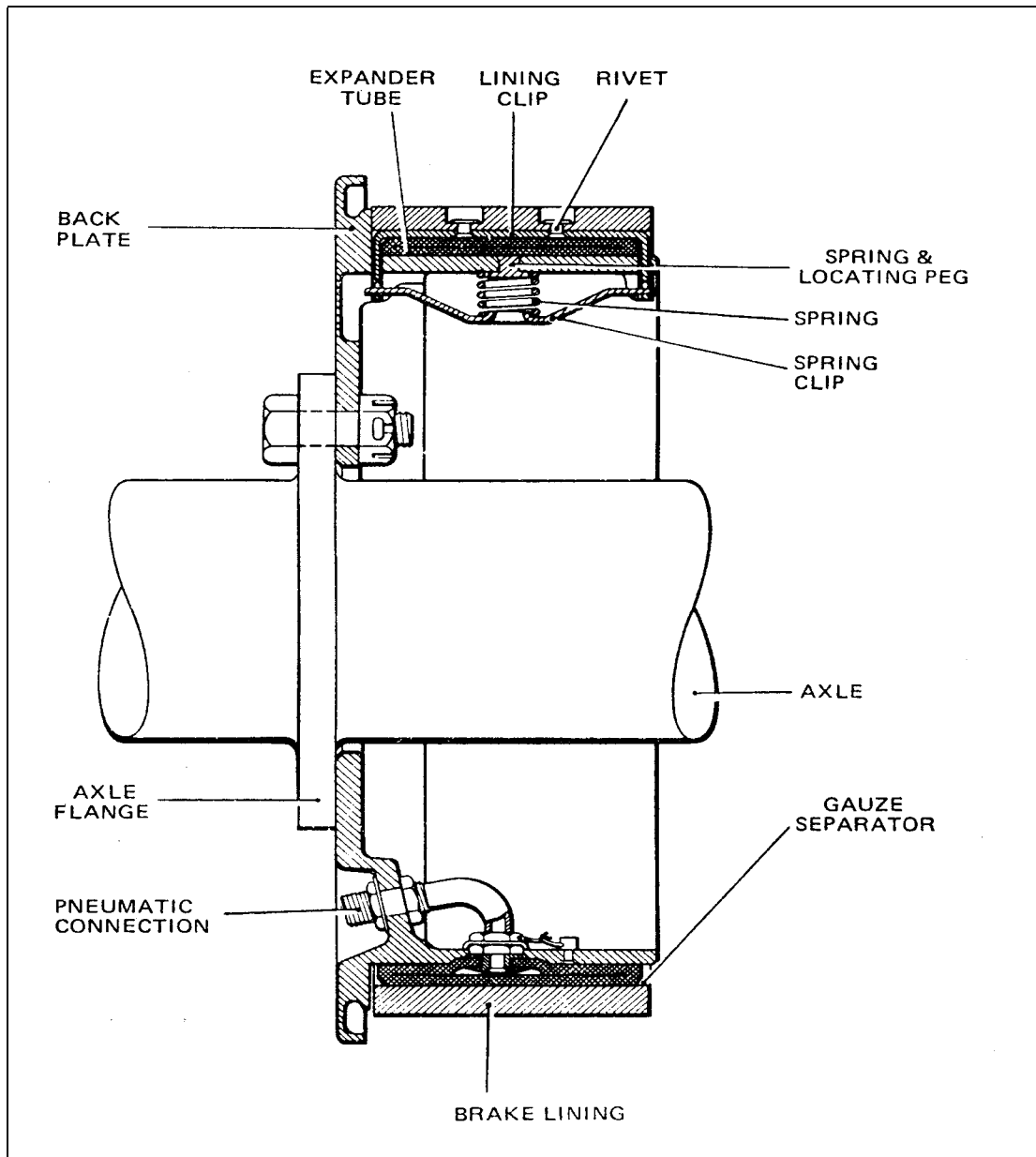

Figure 2 Drum Brake

4.2.2 Back Plate

This unit is cylindrical in shape and is attached to a flange on the axle. It houses the expander tube, brake linings and pneumatic connections.

4.2.3 Expander Tube

This is a circular, reinforced rubber tube of flat cross-section and is fitted around the back plate. It has a pneumatic connection leading through the back plate to the aircraft pneumatic system.

4.2.4 Brake Linings

The complete brake lining assembly is made up of a number of segments of heat-resisting friction material which form a ring around the expander tube and are shaped to conform to the inside radius of the brake drum. Each segment is bonded or riveted

to a metal fitting, which protrudes through the back plate and is secured by a spring clip.

4.2.5 **Separators**

Phosphor-bronze gauze separators are fitted between the ends of the brake lining segments to reduce heat penetration to the expander tube and to exclude carbon particles.

4.2.6 **Brake Drum**

The brake drum is a heavy steel cylinder, attached to and rotating with the wheel and against which the brake lining segments expand to produce the braking action.

4.3 **Operation**

When the pilot's control is operated, air pressure is applied to the inside of the expander tube, which expands and forces the brake linings against the brake drum. When air pressure is released the expander tube collapses and the brake linings are withdrawn from the brake drum by the action of the return springs.

4.4 **Removal/Installation**

4.4.1 Before attempting to work on the brake system or to remove a wheel, it is important to ensure that all air pressure is exhausted from the system. Disconnecting a pipe joint containing air pressure is a dangerous practice and if a wheel is removed with the brake system connected and pressurised, inadvertent operation of the brake could cause the expander tube to burst and possibly damage other parts of the system. In many pneumatic systems a pressure maintaining valve is used to safeguard the brake pressure in case of a leak elsewhere or failure of the compressor, so that lack of pressure in the brake system must be confirmed from the brake system pressure gauge and not by reference to the general system pressure.

4.4.2 When the wheel has been removed, the brake unit can be removed by disconnecting and blanking the air pressure connection and removing the bolts attaching the back plate to the axle flange.

4.4.3 When installing a new brake drum, the protective treatment applied for storage purposes should first be removed with a suitable solvent such as methylated spirits; petrol or paraffin should not be used.

4.4.4 When installing the brake unit, care must be taken to ensure that oil or grease do not come into contact with the linings; operators should also avoid handling the linings as the natural oils from the skin may have an adverse effect. If brake linings do become contaminated they must be considered unserviceable; no attempt should be made to clean the surface with solvents.

4.5 **Inspection**

4.5.1 Drum brakes are not normally accessible for visual inspection when installed on the aircraft. During a pre-flight inspection the back plate and wheel should be examined for signs of overheating and the flexible pneumatic hose between the brake units and the landing gear leg should be checked for damage, security or leaks. Operation of the brakes may be checked by means of the brake pressure gauge and also by checking that air is discharged from the brake relay valve when the brakes are released.

4.5.2 At the times specified in the approved Maintenance Schedule and whenever unsatisfactory operation is suspected, the brake unit should be removed for inspection and overhaul. Disassembly, which should be carried out on a rubber or felt covered bench, is normally straightforward, but reference should be made to the

approved Maintenance Manual for details of any special procedures or tests required. It may be found that the expander tube is stuck to the back plate and extreme care is necessary to prevent damaging the tube; the careful use of smooth, broad tyre levers is sometimes recommended. The assembly position of each brake segment should be marked so that, in the event of their being suitable for further service, they can be returned to their original positions.

- a) Brake segments should be examined for wear by measuring the thickness of the remaining material, the minimum thickness permitted for replacing the linings being stipulated in the approved Maintenance Manual. Any carbon deposits which may have been formed should be removed with a stiff bristle brush.
- b) The back plate should be examined for distortion, damage or corrosion and elongation or cracking at bolt holes and lining clip slots. Protective treatment should be renewed as necessary.
- c) The expander tube should be examined for signs of overheating, which is usually indicated by hardening or flaking of the rubber. The connection threads and nuts should also be in good condition.
- d) The brake lining rivets should be examined for security and the lining clips for cracks or damage, particularly at the corner radii.
- e) The brake drum should be checked for cracks, corrosion and distortion. The friction surface should be free from deep scoring which is likely to cause excessive lining wear and any trace of grease or dirt should be removed with a suitable solvent. If any grease or oil is found on the drum, the cause should be investigated to prevent a recurrence.
- f) New separators should be fitted when the brake is reassembled.

4.5.3 **Test After Reassembly**

Following reassembly the complete brake unit should be installed in an appropriate sized test brake drum and submitted to pressure tests as prescribed by the manufacturer. No leakage should occur and the linings should return to the 'off' position as soon as air pressure is released. The most suitable means of detecting a leak in the expander tube connection is by applying a solution of non-corrosive soapy water which, subsequently, must be washed off. Bubbles will indicate the position of a leak.

5 Disc Brakes

5.1 Most modern aircraft are fitted with hydraulically-operated disc brakes (also known as plate brakes). Light aircraft generally have a single-disc type and larger aircraft a multi-disc type.

5.2 Single-disc Brake Units

5.2.1 A simple single-disc brake unit is shown in Figure 3 and is of a type found on many light aircraft. A single operating cylinder is shown but two or three are often used for increased braking performance and larger aircraft may have brakes using five or six cylinders. The brake unit consists basically of a light alloy torque plate shaped for attachment to the landing gear leg or axle flange, housing a caliper-type hydraulic jack unit and a pair of friction pads. A steel disc is slotted into the wheel and rotates between the friction pads. When the brakes are operated, fluid pressure is applied to the cylinder and forces the operating piston towards the disc, thus squeezing the disc

between the operating and fixed friction pads and thus resisting wheel rotation. When the brakes are released the disc is free to rotate between the friction pads.

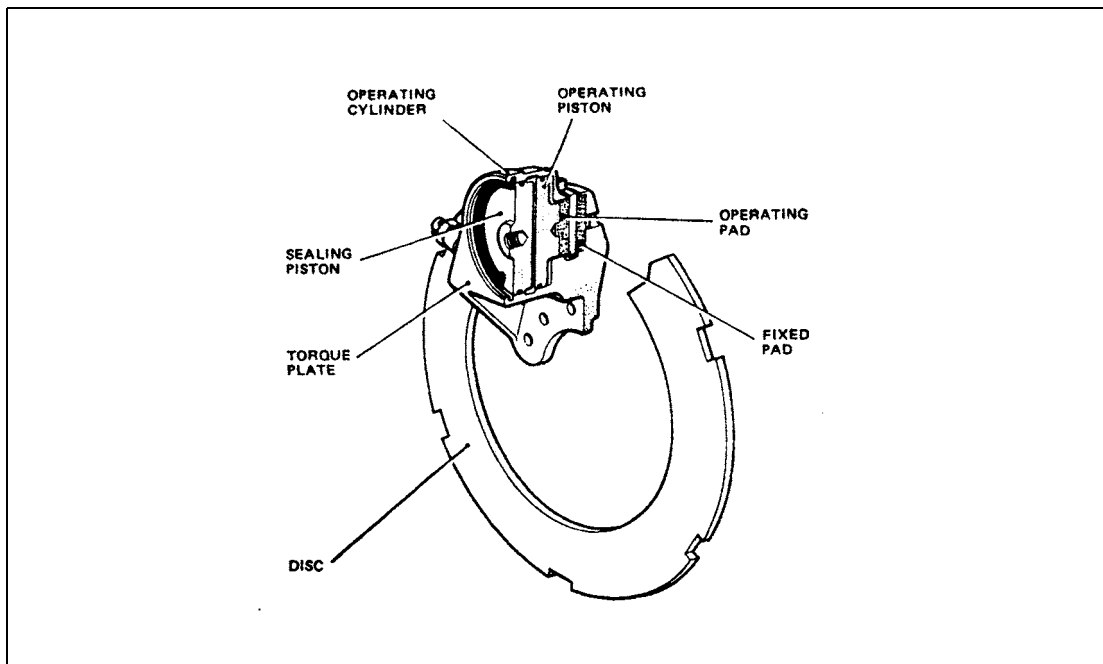

Figure 3 Single Disc Brake

5.2.2 The brake unit should be examined periodically for fluid leaks, damage or corrosion, the friction pads for wear and the disc for scoring or pick-up of surface plating. The single discs used on light aircraft brakes are prone to corrosion and pitting during periods of idleness and this may lead to rapid wear of the friction pads. Discs in poor condition should be replaced or machined to give a clean surface as appropriate. Replacement of worn pads is normally a very simple procedure once the wheel has been removed and often does not necessitate breaking down the hydraulic system. The servicing and repair procedures discussed in paragraph 5.3 are also applicable to single disc brakes but reference should be made to the approved Maintenance Manual for details of any particular limitations, procedures, tests or special tools recommended by the manufacturer.

5.3 Multi-disc Brake Unit

5.3.1 Multi-disc brakes are designed to provide increased friction surfaces for braking purposes. The general arrangement is basically similar to the single-disc brake, but the single disc is replaced by a stack of alternate stationary and rotating discs and a number of operating cylinders are equally spaced around the torque plate. The friction elements are normally in the form of pads attached to either side of the stationary discs, but on some types the rotating discs have sintered surfaces or pads. This type of brake is operated from the aircraft's main hydraulic system, through valves connected to the pilot's rudder pedals.

5.3.2 Manufacture

A typical multi-disc brake unit is shown in Figure 4. In this unit a torque plate and torque tube assembly fits over the axle and is bolted to a flange on the axle; alternative designs are often similarly mounted but prevented from rotating by means of a torque arm attached to a suitable fixture on the landing gear leg or bogie. A number of cylinders are spaced around the torque plate, connected to the hydraulic brake system and house pistons which apply load to the pressure plate. The disc pack

(also known as the heat pack) contains alternate stationary and rotating discs, the stationary discs being keyed to the torque tube and the rotating discs being keyed to drive blocks in the wheel hub. In this unit the stationary discs house the brake pads and the rotating discs are segmented to prevent heat distortion and brake drag. Correct working clearance in the disc pack is maintained by means of adjuster assemblies (paragraph 5.4). Pins attached to the pressure plate and protruding through the torque plate on this brake unit, indicate the amount of wear which has taken place in the disc pack.

- 5.3.3 A further type of multi-disc brake is known as a trimetallic brake. Manufacture is similar to the brake described in paragraph 5.3.2, except that the rotating discs have a metallic compound sintered to their faces and steel segments, known as wear pads, are riveted to the faces of the stationary discs. Alternatively, the faces of both sets of discs may be sintered, or the stationary discs may be plain.

5.3.4 **Operation**

When the brakes are selected 'on', hydraulic pressure is admitted to the cylinders and moves the operating pistons against the pressure plate. The disc pack is clamped between the pressure plate and thrust plate and the friction loads generated between the stationary and rotating members provide the required braking action. When the brakes are released, springs in the adjuster assemblies move the pressure plate back to maintain a working clearance in the disc pack and permit free rotation of the wheel.

5.3.5 **Maintenance**

Contamination of the friction surfaces of a brake unit by fluids used in aircraft servicing operations is highly detrimental to brake operation. It is essential, therefore, to protect brakes from contamination by fuel, oil, grease, paint remover, de-icing fluid, etc., when operations involving their use are undertaken and the condition of the brake units should subsequently be confirmed by inspection.

- 5.3.6 Installed disc brakes may be inspected for signs of fluid leakage, external damage, corrosion, disc pack wear and overheating and the associated hydraulic pipes for security, distortion, chafing or leaks. Brake disc pack wear can be checked by measuring wear pin protrusion, the limits being specified in the approved Maintenance Manual.
- 5.3.7 In some installations a worn disc pack may be exchanged after removing the wheel and thrust or back plate and without disconnecting the hydraulic system, but in order to carry out a detailed inspection the brake unit must be removed from the axle.
- 5.3.8 At the periods specified in the approved Maintenance Schedule the brake unit should be removed for inspection and overhaul. The wheel should first be removed (paragraph 3.2) and the hydraulic pipe couplings should be disconnected at the brake and fitted with suitable blanks. In some cases fluid will drain from these pipes and bleeding will be necessary (paragraph 5.5) after re-connection, but in other cases connection is by self-sealing couplings which isolate the hydraulic system from the brake unit. The brake unit attachment bolts (and, where fitted, the torque link) should then be removed and the unit carefully withdrawn.

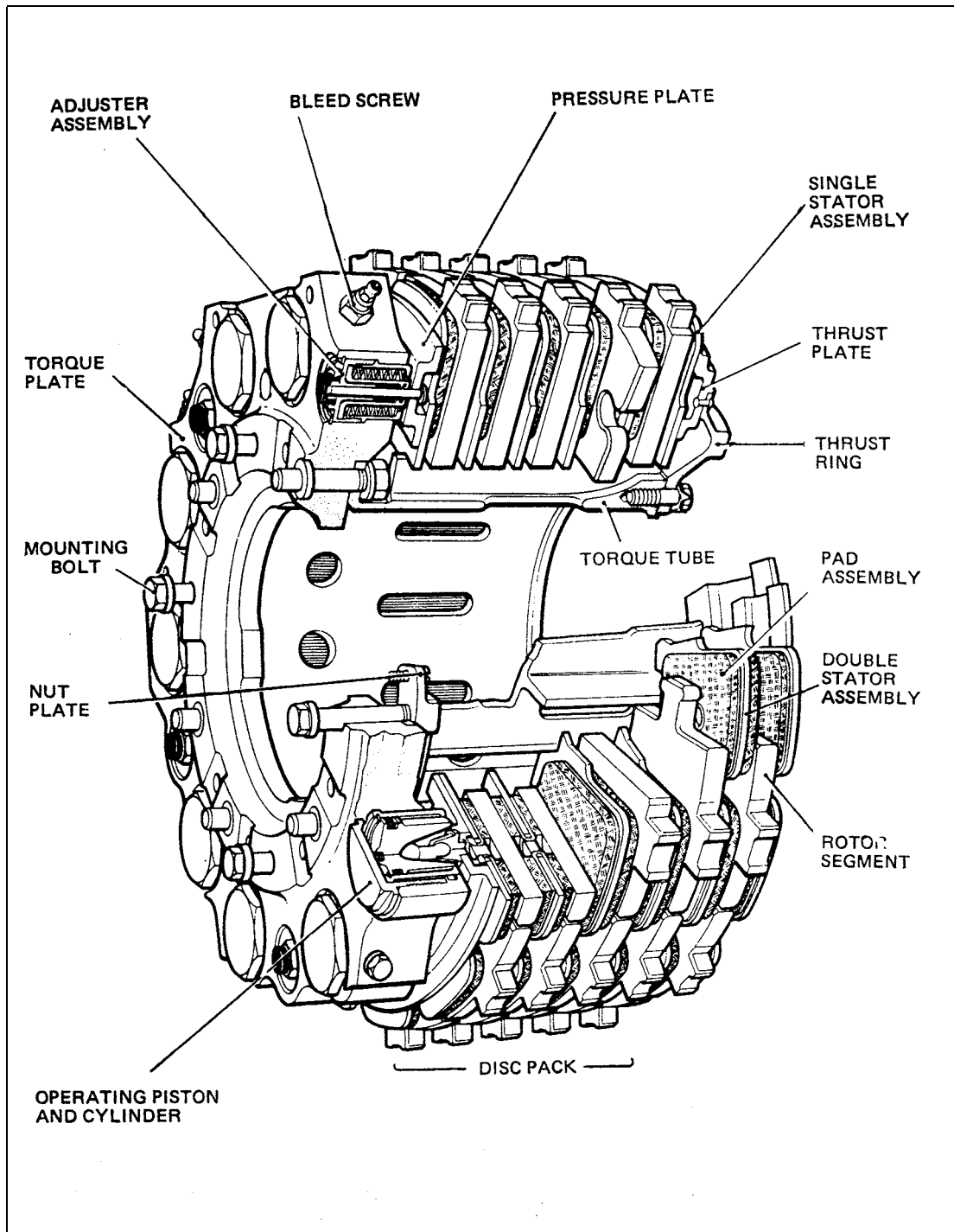

Figure 4 Multi-disc Brake

5.3.9 Following its removal, the brake unit should be dismantled, cleaned and inspected. All metallic components should be thoroughly cleaned and dried; if chemical solvents are used they must not be allowed to come into contact with the elastomeric seals. Inspection of components should be related to any limitations or repair schemes specified by the manufacturer and will normally include the following:

- a) Rotating discs should be checked for excessive scoring, corrosion, distortion and wear on the friction surfaces and driving slots. Light surface damage which would not cause excessive wear of the friction pads may be acceptable, but deep scores or corrosion should be ground out within prescribed limits. Heat damage may

cause surface cracking and, if present, must be within limits specified by the manufacturer for the disc to be re-used.

- b) Brake friction pads should be inspected for excessive wear (normally checked by measuring individual pad thickness and weighing the complete pack), burning, flaking, cracking, security of attachment to the stationary disc and contamination by oil or grease. It is normally specified that, if any pad is damaged or worn beyond limits, or contaminated with oil or grease, the complete set should be changed. In some instances it is also specified that the rotating discs should be changed. If part-worn pads are to be re-used they must be reassembled in their original location.
 - c) The torque plate, torque tube and thrust plate should be examined for cracks, corrosion, distortion and damage, particular attention being paid to bolt holes and other highly stressed areas. Cylinders and pistons should be inspected for scores or other damage and springs inspected for corrosion and given a load/compression test as specified by the manufacturer.
 - d) Operation of the self-adjusting mechanism should also be checked and the friction force applied to the retraction pin measured (Figure 5).
- 5.3.10 Protective treatment should be applied as necessary to the metal components and the brake unit reassembled and tested for leaks and correct operation. It is normally specified that new seals, gaskets and self-locking nuts should be used for reassembly and all fasteners torque loaded in accordance with the manufacturer's recommendations. The unit should be primed with hydraulic fluid and blanks fitted to all connections.
- 5.3.11 When re-installing the brake unit on the axle, care must be taken not to spill fluid on the disc pack. Jointing, sealing or anti-seize compounds should be used where specified and all fasteners and pipe connections should be torque loaded and locked to the manufacturer's requirements.

5.4 **Adjuster Assemblies**

- 5.4.1 The diagrammatic arrangement of a typical adjuster assembly is shown in Figure 5. At least two adjuster assemblies are fitted to the majority of disc brakes, their purpose being to maintain a suitable running clearance in the brake pack. In a single-disc brake the retraction pins are often attached directly to the operating pistons but on multi-disc brakes they are usually attached to the pressure plate. In operation, movement of the piston or pressure plate is transmitted via the retraction pin and friction bush to compress the adjuster spring and move the guide until it abuts the torque plate. When the brakes are released the adjuster spring pulls the guide back until it contacts the spring housing, the clearance between the guide and torque plate being the designed running clearance. As wear takes place in the discs the pressure plate has to move further forward, thus pulling the retraction pin through the friction bush by an amount equal to disc wear, but maintaining the design clearance when brakes are released. On some brake units wear may be assessed by measuring the protrusion of the retraction pin.

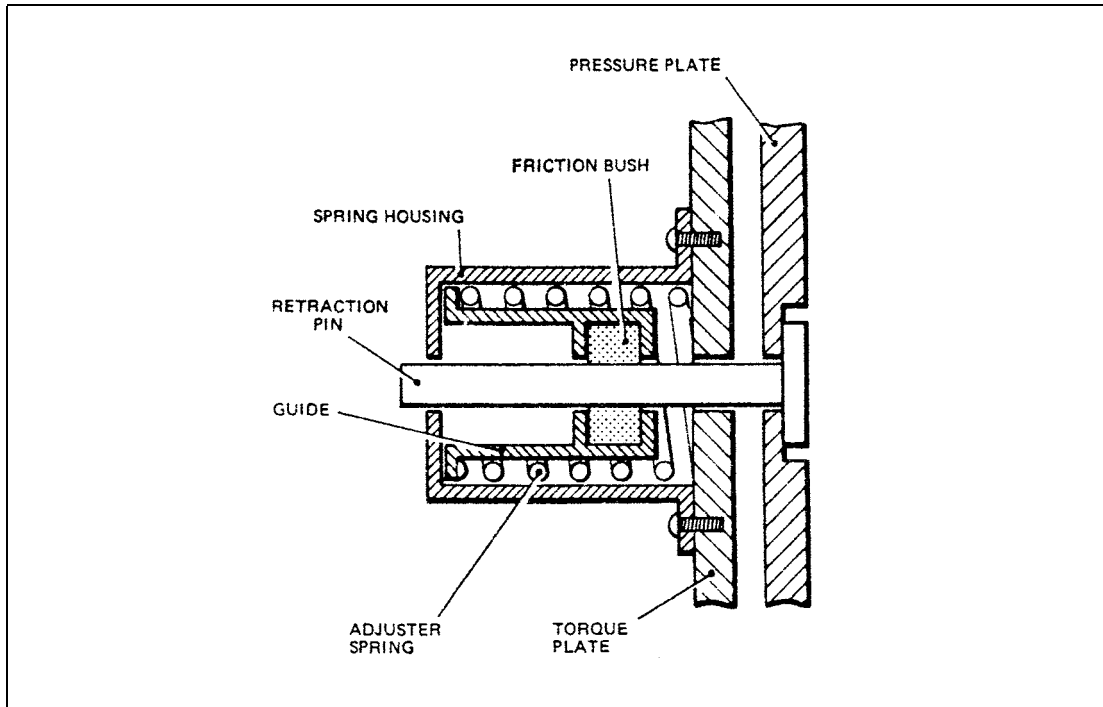

Figure 5 Adjuster Assembly

- 5.4.2 On initial assembly of the adjuster a special tool is used to position the retraction pin at the position of maximum protrusion through the friction bush. The pin takes up its initial operating position when the brakes are first pressurised.
- 5.4.3 On some types of disc brakes a conical friction bush is used and friction is adjusted by torque loading the retaining nut to a specified value, whilst on others, provision is made for manual adjustment of the working clearance.
- 5.4.4 Correct operation of the adjuster assemblies must be checked whenever the brakes are tested and should result in free rotation of the wheel when brakes are released.

5.5 Bleeding the Brakes

5.5.1 General

The presence of air in the hydraulic brake system will degrade the performance of the brakes and must be removed after initial installation and whenever brake response becomes sluggish.

- 5.5.2 The exact method of bleeding the brakes will depend to a large extent on the particular aircraft system and reference should be made to the approved Maintenance Manual for the aircraft concerned. However, the normal method of bleeding is to pressurise the brake system and open the bleed screws fitted to the brake units, allowing hydraulic fluid to flow through the system until bubble-free fluid is discharged; the bleed screws are then closed and brake operation tested. Bleed fluid should be piped to a suitable container and must not be allowed to come into contact with the disc pack.
- 5.5.3 On low pressure systems fluid is forced through the brake unit by slowly pumping the appropriate brake pedal. Care must be taken to ensure that the reservoir is kept topped up during this operation, since further air might be introduced if the fluid level is allowed to fall too low.

5.5.4 On high pressure systems the associated hydraulic accumulator is pressurised and as the brake pedal is depressed, fluid is forced out of the bleed screws under pressure. In this type of system it is sometimes recommended that only a specified quantity of fluid is discharged and it may be necessary to bleed other parts of the system such as, where fitted, the servo system from the brake pedals to the control valves, or the normal and emergency accumulators, before bleeding the brakes. After bleeding, the appropriate reservoir should be topped up as necessary.

5.6 Testing the Brakes

Brakes are normally tested after overhaul and after installation on an aircraft, while the aircraft is still jacked up. The brakes should be applied several times then released; there should be no leakage and the brakes should restrain wheel movement when pressurised and permit wheel rotation when released (free rotation is important, because binding brakes can cause overheating and increase take-off ground-run distance). Operation of the emergency and parking brake controls should be checked and, on completion, a full brake sense check should be carried out in a manner which will ensure correct brake operation for any brake application. Special care should be taken to ensure that the hydraulic systems are correctly connected and in particular that the main system and not the emergency system, is connected through the anti-skid device.

6 Brake Temperature Monitoring System

6.1 On some aircraft, in order to inform the pilot of excessive build-up of heat in the wheel brakes, a brake temperature monitoring system is fitted. A typical system includes a temperature sensor at each wheel, which supplies information to a central monitor and warning unit on the flight deck. The monitor contains a temperature gauge and a selection button for each wheel. The gauge normally records the temperature at the hottest brake and a button illuminates when the associated brake temperature exceeds a predetermined amount. When any button is pressed, the gauge records the temperature at the associated brake.

6.2 For testing purposes, operation of a test switch on the control unit will cause all buttons to illuminate and the gauge to read within a test signal range when all circuits are serviceable.

6.3 Installations vary considerably between aircraft and trouble-shooting charts are normally included in the appropriate Maintenance Manual to enable faults to be traced. Routine maintenance should include inspection of the sensors and associated wiring for security and damage and functional tests of the system using the appropriate test switches.

7 Skid Control

7.1 The braking systems of most modern aircraft are provided with a means of preventing the wheels from skidding on wet or icy surfaces and of ensuring that optimum braking effect can be obtained under all conditions, by modulating the hydraulic pressure to the brakes. Anti-skid units sense the rate of change of wheel deceleration, decreasing the hydraulic pressure applied to the brakes when a high rate of increase in deceleration (i.e. consistent with an impending skid) occurs and restoring it as the wheel accelerates again. A modulator is often fitted in conjunction with the anti-skid unit, to restrict the flow of fluid to the brakes after initial brake application and to conserve main system pressure. There are basically two types of anti-skid systems in use, the mechanically controlled and the electronically controlled.

7.2 **Mechanical System**

7.2.1 **General**

The anti-skid unit is mounted either on the brake unit torque plate or within the axle bore and is connected into the brake hydraulic circuit at the brake unit. The anti-skid unit consists of a valve assembly connected to a flywheel, which is driven by the associated wheel.

7.2.2 **Operation**

During normal braking action (i.e. when no skid is present) the flywheel rotates at the same speed as the drive and the valve is closed, allowing maximum hydraulic pressure to be applied to the brake operating pistons. When the rotational speed of the wheel decreases rapidly, as when a skid begins to develop, the inertia of the flywheel alters its angular relationship with the drive shaft and, through the action of a cam and push rod arrangement, the valve opens to relieve the pressure applied to the brake, thus reducing braking action and allowing the wheel to increase its rotational speed. As the wheel accelerates, the angular relationship between flywheel and drive returns to normal and the valve closes, increasing pressure to the brake. If the wheel bounces clear of the ground after brakes are applied, the adjustment of the anti-skid unit allows the brake to be completely released for a sufficient period of time to ensure that the brake is off when the wheel contacts the ground again.

7.2.3 **Installation**

The mounting details of the various types of mechanical units vary considerably and reference should be made to the appropriate Maintenance Manual for details of any particular installation. An external unit is driven by means of a rubber tyre surrounding its flywheel housing and engaging in a track on the landing gear wheel. The whole unit is spring-loaded, or the mountings shimmed, to maintain satisfactory driving contact with the track. The tyre loading is normally checked after installation by measuring the flat produced on the rubber tyre at its point of contact with the track. An axle mounted unit is driven by means of a shaft, which is splined into the anti-skid unit at one end and into a drive housing bolted to the wheel hub, at the other. All types of units are marked with the correct direction of rotation and this must be checked before installation.

7.2.4 Bleeding of the anti-skid unit is normally achieved when bleeding the main brake system but independent bleeding may be necessary after installing a unit. This is accomplished by fitting a drain pipe at the exhaust connection, rotating the drive smartly in the direction of rotation, then bringing it to rest. Each time rotation is stopped fluid will be discharged from the exhaust port and bleeding should be continued until the discharged fluid is free from air, then the pipe connections remade.

7.2.5 **Inspection**

At the periods specified in the approved Maintenance Schedule, the anti-skid unit should be inspected as follows:

- a) The unit should be cleaned and inspected for security, signs of corrosion, external damage and cracks.
- b) With brakes applied, the unit should be checked for signs of external leakage of hydraulic fluid.
- c) The pipelines should be checked for damage or distortion and the connections for security of attachment.

- d) The driving tyre and wheel track should be inspected for correct loading and alignment and the tyre for excessive wear.

NOTE: It is possible to lock the spring-loaded type units out of contact with the wheel track by inserting a pin in the mounting stud. This is normally done to facilitate wheel removal, but it is recommended that a red streamer should be attached to the pin as a visual reminder that the anti-skid unit is out of operation.

- 7.2.6 At the end of its overhaul life an anti-skid unit should be returned to the manufacturer or an approved firm for overhaul. Testing after overhaul requires the use of specialised equipment which is not normally held by operators. After removal, all fluid connections and orifices should be properly blanked, the fluid being retained as a guide to the internal condition of the unit. Packing should be suitable for the method of transit and the destination.

7.3 **Electronic System**

- 7.3.1 The system comprises a wheel speed transducer, a control unit and an anti-skid valve in the brake pressure line, together with associated switches and check-out and warning lamps. The wheel speed unit may supply either d.c. or a.c. depending on the type of system used. Operation is basically similar to the mechanical system but the use of sophisticated logic circuits in the later types of electronic control units enables much finer control to be exercised. Further refinements such as strut oscillation damping circuits, touch-down protection and locked wheel protection, may also be incorporated and some systems automatically de-activate at low speed to prevent interference with normal taxiing manoeuvres.

- 7.3.2 The method by which the wheel speed signal is processed in the control unit varies from type to type, but all operate on the basis that if any brake produces more torque than can be supported by the friction between the tyre and ground for the existing wheel load, the resulting impending skid will produce a smaller rotational velocity signal from the affected wheel. This reduced signal is detected by the anti-skid control circuits, which send a signal to the anti-skid control valve, causing brake pressure to be reduced sufficiently to correct the skid condition. Brake pressure will be re-applied to a level just below that which caused the skid and will then increase at a controlled rate.

- 7.3.3 Control units normally contain circuits which provide warning of failure in the system and a self-test facility which enables the serviceability of the various components to be checked. Controls for the operation and testing of the anti-skid system are contained in the control unit and in the flight compartment.

- 7.3.4 Some systems operate by providing a continuous bleed from the brake pressure line and in these cases the parking brake operates a cut-off valve in the brake return line.

7.3.5 **Maintenance**

The inspection, testing and maintenance of any particular anti-skid system will vary considerably between different installations and details should be obtained from the approved Maintenance Manual. However, the self-test facility normally enables complete testing of the system to be carried out and the test circuit is designed to facilitate location of faulty components. A visual inspection of the system should include the following:

- a) The various components should be examined for damage, security and where appropriate, fluid leaks.
- b) Pipelines should be examined for security, chafing and fluid leaks, particularly at connections.

c) Electrical cables should be examined for security, chafing and damage by fluids or heat.

7.3.6 The removal and installation of components in the anti-skid system often requires the observance of certain safety precautions. These precautions are detailed in the approved Maintenance Manual and normally include the fitting of landing gear ground locks and door locks and depressurising the appropriate hydraulic system.

8 Low Pressure Brake Systems

8.1 General

Most light aircraft are fitted with an independent hydraulic system for each brake, similar to that shown in Figure 6. On some aircraft a handbrake system is connected to each brake through a shuttle valve, while on others a parking brake control applies a mechanical lock to the footbrake linkage when brakes are applied. The main components in each system are a fluid reservoir and master cylinder, connected mechanically to the brake pedals and hydraulically to the brake operating cylinder.

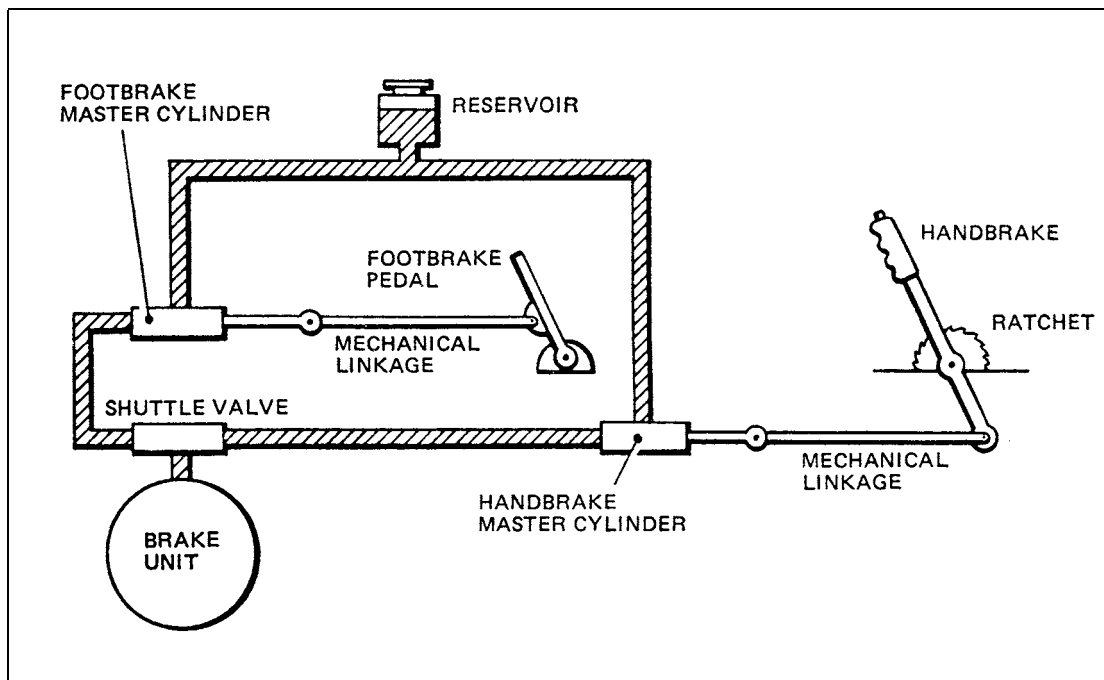

Figure 6 Simple Low-pressure Brake System

8.2 Operation

As the brake pedal is pressed, a piston in the master cylinder forces fluid through the pipelines to the brake operating cylinder, the braking force depending on the force exerted on the brake pedal. When the pedal is released, a return spring in the master cylinder returns the piston to its original position and pressure is relieved. Handbrake operation is similar except that the shuttle valve moves to allow pressure to the brake unit and close off the port from the footbrake master cylinder; brakes are held on by a ratchet device in the handbrake mounting. With the alternative parking brake system, the brake should be set by applying pressure with the footbrake, then the parking brake operated to lock the footbrake linkage; subsequent footbrake application will release the locking catch.

8.3 **Bleeding and Testing**

After installing the braking system and whenever faulty system operation is suspected, the aircraft should be jacked up and the following procedure carried out, subject to specific instructions contained in the approved Maintenance Manual.

- a) Ensure that the brake fluid reservoir is topped up.
- b) Undo the bleed screw in the brake unit and position a container to catch draining fluid. It is usually advisable to fit a tube between the bleed screw and container, to avoid contaminating the brake pads.
- c) Pump the brake pedal slowly until bubble-free fluid issues from the bleed screw, topping up the reservoir as necessary, then tighten the bleed screw.
- d) Apply the footbrake and ensure that the brake is operating, then release the brake and ensure that the wheel rotates freely.
- e) Hold the footbrake fully on for 30 seconds and check for hydraulic leaks. The brake should still be applied, with no apparent pedal movement, at the end of this time.
- f) Repeat e) using the handbrake or parking brake as appropriate.

8.4 **Maintenance**

- 8.4.1 Little maintenance is required with this type of brake system except for ensuring that the reservoir is kept topped up to the required level with the specified fluid. Use of the correct fluid is most important, since the piston and shuttle valve seals are often manufactured from a material which is compatible with a limited range of fluids and might deteriorate rapidly if a different fluid were introduced. Cleanliness is also an important aspect and every care should be taken to prevent the introduction of dust and dirt into the system when topping up the reservoir.
- 8.4.2 The components and pipelines should be inspected periodically for security, fluid leakage and correct operation. Flexible pipes are often fitted between the brake unit and landing gear leg and it should be confirmed that the pipes are secure and have freedom of movement throughout the range of movements of the landing gear.
- 8.4.3 Spongy operation of the brakes may be caused by air in the system, which should be bled as described in paragraph 8.3. Fluid bled from the brakes should not be replaced in the system.
- 8.4.4 Loss of brake pressure, or inability to hold the brakes on, may be due to faulty or worn seals in the master cylinder or shuttle valve. Extreme care is necessary when replacing these seals, as they usually have to be expanded over the valve or piston. The use of an assembly tool is often recommended and the seals should be lubricated with system fluid before fitting. Cleanliness is of the utmost importance since dirt and grit could prevent proper sealing and possibly score the piston or cylinder surfaces.

9 **High Pressure Brake Systems**

- 9.1 High pressure braking systems use the normal aircraft hydraulic system to provide fluid, under pressure, to the brake units. A brake system accumulator stores energy in the brake system for use in the event of normal system pressure not being available and an emergency pneumatic system is frequently included to safeguard brake operation in the event of complete hydraulic failure. A simplified system is shown in Figure 7.

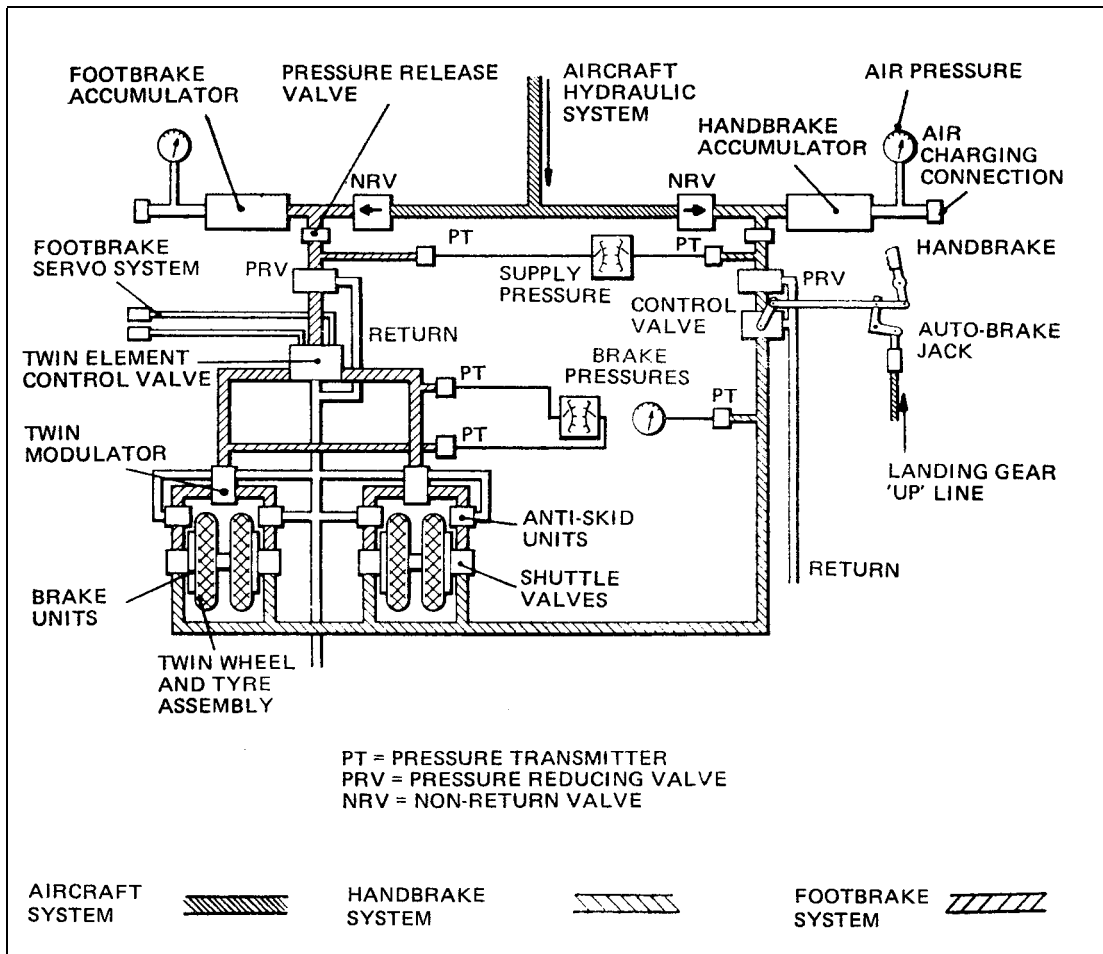

Figure 7 Simple High-pressure Brake System

- 9.2 Operation of the brakes can be controlled from either pilot's position, by brake pedals attached to the rudder bar. Application of left or right pedals at either pilot's station causes operation of the associated left or right brakes.
- 9.3 The brake pedals are linked through a system of levers and cables, or a hydraulic servo system, to a control valve (normally located adjacent to the main wheel bays to minimise the length of pipe run) which controls hydraulic pressure according to the position of the brake pedals. This pressure is often reduced through a pressure reducing valve and modulated by an anti-skid valve, before being applied to the brake cylinders.
- 9.4 **Adjustment**

The accurate setting-up of the mechanical linkage between the rudder pedals and control valve is very important since it controls the brake pressure in relation to pedal movement and must be identical in both left and right braking systems. Details of the setting-up procedure for a particular aircraft system will be found in the approved Maintenance Manual, but in a normal system, levers and bellcranks are locked in position by the insertion of rigging pins and the connecting rods and cables adjusted to fit these fixed locations. Alternatively, graduated quadrants may be fitted to show the angular positions of particular levers so that the connecting components may be correctly adjusted. Cables should be tightened to the tension quoted in the Maintenance Manual.

9.5 Bleeding

Bleeding of the hydraulic braking system is normally carried out using an approved hydraulic servicing rig connected into the aircraft system at selected quick-release couplings. It is normal practice to bleed the main hydraulic system first to ensure the fluid passing to the brakes is free from air. A typical procedure would be as follows:

- a) Install landing gear ground locks and door locks and chock wheels.
- b) Release parking brake.
- c) Connect hydraulic servicing rig to aircraft system and adjust to normal operating pressure.

NOTE: Cleanliness of the rig connections and fluid are most important and every precaution must be taken to prevent the ingress of foreign matter into the aircraft system.

- d) Apply and release brakes several times.
- e) Set hydraulic pressure to a low value (as specified in the Maintenance Manual) and slowly pump the brake pedals to discharge the brake accumulator, then set the parking brake.
- f) Release brake unit bleed screws and bleed until bubble-free fluid is discharged, then close bleed screws.
- g) Reset hydraulic pressure to normal system pressure and release parking brake.
- h) Operate foot brakes several times and check operation and release of brakes by observing movement of the disc return springs.
- i) Remove servicing rig, check level of fluid in hydraulic reservoir and restore aircraft to normal.

9.6 Testing

Operation of the wheel brakes may be checked by operating the brakes normally and visually observing the action of the disc return springs and their efficiency may be assessed during taxiing. When a full functional check is required however, such as after initial installation or following major component change, a more detailed procedure must be followed. This will normally entail the installation of landing gear ground locks and door locks, or jacking the aircraft and carrying out the following operations:

- a) Install a suitable pressure gauge at each brake unit bleed fitting.
- b) Provide hydraulic power (by connection of a hydraulic test rig or by running an aircraft hydraulic pump).
- c) Check operation of brake system warning lights and gauges by reference to the relevant Maintenance Manual.
- d) Fully depress each brake pedal in turn, note the pressure recorded at each pressure gauge and check brake operation.
- e) Release brake pedals, visually or physically check that the brakes are off and check that the readings on the pressure gauges are zero or less than a specified maximum pressure.
- f) Repeat checks with parking brake and, where fitted, the alternative hydraulic system.

NOTE: On some aircraft which are fitted with an automatic brake system to stop the wheels during landing gear retraction, the test may also include selecting the landing gear up and carrying out a function check.

9.7 Maintenance

9.7.1 The main items of maintenance common to all modern aircraft with high pressure braking systems are the checking of fluid levels and accumulator gas pressures, followed by replenishment as necessary. When recharging the gas in accumulators the system hydraulic pressure should be fully released and when topping up a hydraulic reservoir it must be ensured that all the hydraulic rams are in their appropriate positions. The various components and pipelines should also be inspected at frequent intervals for chafing, security, satisfactory bonding and freedom from leaks.

NOTE: High pressure air or nitrogen charging cylinders should be fitted with relief valves and extreme care taken to ensure that specified accumulator gas pressures are not exceeded.

9.7.2 The procedure necessary for the replacement of components in a braking system will be found in the approved Maintenance Manual and particular attention should be given to the prescribed safety precautions. In particular, since a high pressure braking system contains a pressurised accumulator, the system will always be under pressure whether the normal aircraft hydraulic system is operating or not and this pressure must be released before a disconnection is made. The normal method is to slowly pump the brake pedals until the accumulator is discharged and this also provides a means of checking internal leakage in the system by observing the number of full brake applications available.

10 Overheated Brakes

10.1 The action of braking converts kinetic energy into heat and the temperature of brake units will, therefore, rise during use. There is a limit to the amount of heat which can be absorbed and dissipated by a brake and wheel unit and excessive use of the brakes, such as during a rejected take-off or prolonged periods of taxiing, can lead to overheating and combustion and, in extreme cases, result in rupture of a wheel assembly.

10.2 One of the main problems associated with overheated brakes or brake fires, is how to cool the wheel without inducing uneven contraction of the metal. This could cause fracture of the wheel and explosive release of the air in the tyre. Serious and sometimes fatal, accidents have been known to occur as the result of the application of an incorrect extinguishant to a brake fire.

10.3 A small fire, due perhaps to combustion of grease on the wheel, would probably cause less damage in burning itself out than might be caused by attempting to extinguish it. A short period should be allowed, therefore, to check the progress of the fire before attempting to put it out. In some cases however, such as when the fire is fed by leaking hydraulic fluid, immediate action will be necessary; some aircraft wheels are made from magnesium alloys which, once ignited, burn fiercely and are difficult to extinguish.

10.4 Tests have shown that the safest extinguishant to use is a dry chemical agent and this must be used whenever possible. It should be applied by an operator standing in line with the tyre's rolling path and at a safe distance; an overheated wheel should never be approached in line with the axle.

10.5 If a wheel fire has to be extinguished and no dry chemical is available, CO₂ or foam may be used but extreme caution is necessary. The extinguishant should be applied as lightly as possible from a distance of at least 6 metres (20 feet) to reduce the likelihood of uneven cooling and the area should be kept clear after the fire has gone out, until such time as the wheel and brake are completely cooled.

INTENTIONALLY LEFT BLANK

Leaflet 32-30 Tyre Wear Limitations

1 Introduction

- 1.1 British Civil Airworthiness Requirements require that for certification of new types of aircraft, the depth of tyre tread below which wet braking friction characteristics are impaired should be specified at the time of certification; it is also required that it should be possible to determine, in operational conditions, when the tread depth is worn below this limit.
- 1.2 This Leaflet provides general guidance on the subject of tyre wear limitations for operators of all public transport aeroplanes of more than 5700 kg maximum weight on the UK Register for which a limiting tyre tread depth is not otherwise available.

2 Discussion

- 2.1 Accidents and incidents, resulting from both loss of braking friction and loss of directional control on wet runways, continue to occur. While the scheduled accelerate-stop and landing distances provide some allowance for deterioration in friction, it has been established that this allowance is not sufficient to maintain the required level of safety if tyres which are more than 80% worn are used in wet runway operations.
- 2.2 As it is not possible fully to allow for this by increasing the scheduled distances (because of the frequency of incidents caused by loss of directional control, even on the most favourable wheel arrangements), the CAA favours the retention of current scheduled distances, together with a recommended minimum tread depth applicable to all aircraft tyres.

3 Recommendation

- 3.1 In the absence of evidence of the safety of a lower limit for a particular aircraft/tyre/operation combination, it is recommended that a tyre be withdrawn from service when it is worn to such an extent that its wet runway performance would be seriously impaired. This may be defined as when:
 - a) it is worn such that any groove has a depth of less than 2mm of tread for more than one quarter of the tread circumference; or
 - b) at any place on the circumference the tread pattern is worn to a depth of less than 2mm across the whole width of the tread in contact with the runway.

NOTE: This is not a rigid definition and equivalence may be provided if, for example, tyre wear is such that whilst one groove is less than 2mm all the others are 3mm or more.

INTENTIONALLY LEFT BLANK

Chapter 33 Lights

Leaflet 33-10 Emergency Floor Path Lighting System

1 Introduction

This Leaflet provides additional information on the installation of an Emergency Floor Path Lighting System required by the Air Navigation Order Schedule 4, scale Z(3).

2 Interpretation of Requirements

2.1 The following guidance information is provided with the objective of ensuring a consistent and uniform interpretation of the emergency floor path lighting system requirements.

2.2 The markings and illumination provided should enable the passenger to visually identify the escape path along the cabin aisle floor.

NOTE: It is not necessary to provide visual guidance to enable passengers to move from their seat to the cabin aisle.

2.3 The illumination should be of sufficient intensity to enable the passenger to identify features bounding the cabin aisle.

2.4 Where exits are to be found in one direction only, the system should not tend to lead the passenger toward the end of the cabin where there are no exits.

2.5 The escape path markings, coupled with exit markings, should be so arranged that a passenger will not tend to proceed along the cabin aisle past any available exits. It is recommended that conspicuous markers be placed at the point of access from the cabin aisle to the exit.

2.6 Exit Identification

2.6.1 Only those exits which are either 'designated' emergency exits or 'excess' emergency exits should be identified by the emergency floor path lighting system.

NOTE: 'Designated' emergency exits are the minimum required for the certificated passenger capacity. 'Excess' emergency exits are additional exits to the minimum required which satisfy the same arrangement, marking and lighting requirements as for designated exits and which are also readily accessible.

2.6.2 The exit should be positively identifiable to enable a passenger to proceed to it without hesitation in conditions where the exit is either open or closed. All exits likely to be available for use in an emergency should, therefore, have exit identifiers.

2.6.3 Exit identifiers of floor level exits need to be located so that they can be seen directly when adjacent to the last aisle marker, or in the case of a flood-lit system, within the flood-lit zone, and viewed on the vertical centre line of the aisle at a height no more than 4 feet above the cabin floor level. Additional cues to a passenger may, however, be provided as an alternative such as horizontally mounted exit identifiers located on an aft or forward bulkhead in the vestibule leading to an exit and within direct line of sight of a passenger when approaching the vestibules from the aisle.

2.6.4 Exit identifiers should, wherever practicable, be located at such a distance from the floor that they will not be obscured by any strewn hand baggage likely to be present

in an emergency evacuation. It is, therefore, recommended that exit identifiers be located between 18 inches and 4 feet above the cabin floor level.

- 2.6.5 Where exit identifiers are mounted on cabin sidewalls and located close to passenger seats, they should be visible from the aisle with the seat next to the identifier occupied. This takes account of a passenger seated next to an exit being incapacitated. (A passenger slumped forward or sideways should also be considered.)

2.7 **Escape Path Markings along Cabin Aisle Floor**

- 2.7.1 Where single point incandescent type or electroluminescent strip type floor track markers are employed, the CAA recommends a distance between markers no greater than 20 inches (thus permitting a maximum distance between markers of 40 inches under typical Minimum Equipment List (MEL) conditions).

NOTE: Where incandescent lights are installed on the side of seats the distance between lights should not exceed 40 inches.

- 2.7.2 Floor track cabin aisle markers should be clearly visible when viewed from the aisle centre line at a height of 4 feet above the cabin floor.

- 2.7.3 At each end of a passenger cabin it is recommended that there are red/orange floor track cabin aisle markers (either, at least two closely spaced incandescent markers or, a short length of electroluminescent strip) to highlight clearly the ends of the aisle.

2.8 **Escape Path 'Flood Lighting' of Cabin Aisle**

- 2.8.1 Where a 'flood lighting' system is employed the maximum distance between light sources is to be agreed with the CAA and this will be dependant upon the intensity and distribution of light available.

2.9 **Aisle Cues for Overwing Exits**

- 2.9.1 Floor track marking system aisle cues for overwing exits are recommended to comprise three, with a minimum of two, closely spaced red/orange markers or a suitable length of red/orange strip-lighting, adjacent to the access route to overwing exits.

- 2.9.2 Where access to an overwing exit is achieved by a dual access route, the aisle cues should be located at the entrance to both access routes or be located so as not to bias one route when compared with the other.

- 2.9.3 Escape Path flood lighting systems do not normally provide adequate aisle cues for overwing exits and should be complemented by the provision of some discrete cues so located that they can be seen by a passenger at a maximum height of 4 feet above the cabin floor when moving down the aisle (strobe lights are not considered to be effective cues, especially when smoke is present).

2.10 **Cross Aisle Escape Path Markings**

A similar level of floor proximity escape path marking/illumination should be provided in cross aisles on multi-aisle aircraft to that provided for the cabin main aisles.

2.11 **The 25 Percent Rule**

- 2.11.1 Each escape path marking system is required to meet existing FAR/JAR/EASA CS 25.812 requirements. In particular, FAR/JAR/EASA CS 25.812(l)(1) requires that not more than 25 percent of the escape path marking system lights are rendered inoperative after any single transverse vertical separation.

- 2.11.2 For systems in which the lights are controlled by remote transmitters there must be sufficient transmitters installed to ensure that the FAR/JAR/EASA CS 25.812(l)(1)

requirement can be met even though, in a crash, there may be a considerable distance between the two vertically separated parts of the fuselage.

3 Evaluations

- 3.1 The means provided in showing compliance with the requirement of the ANO shall be the subject of an evaluation by the CAA. In addition, all concepts not already approved shall be the subject of a demonstration to determine both the strengths and weaknesses of a particular system.
- 3.2 Engineering evaluations and demonstration tests should be conducted in conditions of darkness either at night or where conditions have been simulated by preventing daylight from entering through windows or through exits whether open or closed.
- 3.3 Where it is intended that an aircraft's MEL is to permit continued operation of the aircraft with some elements of the system unserviceable, the test subject demonstration should be conducted with the system configured so as to simulate the relevant MEL standard.
- 3.4 A demonstration should clearly show, to the satisfaction of the CAA, that test subjects, on leaving their seat in any part of the passenger compartment and entering the cabin aisle can using the visible signs and markings, immediately determine in which direction(s) exits are to be found using visual references only.
- 3.5 The demonstration is intended to establish that there are adequate visual references which will provide the necessary orientation of the passengers. It is not necessary to assess the passenger evacuation rate under these conditions. Obstructions created by loose cabin baggage, etc., need not, therefore, be simulated, except in so far as baggage might interfere with an illumination system.
- 3.6 In assessing the effectiveness of all visual cues, the existing emergency lighting system which provides illumination from locations more than 4 feet above the cabin aisle floor, must be switched off. It is not intended that the test should be performed in conditions of smoke but simply taking into account its blanketing effect. Therefore, care needs to be taken to ensure that, in the absence of an overlaying smoke, the floor proximity system is prevented from illuminating and hence reflecting light from parts of the cabin above the 4 foot level.
- 3.7 Test subjects should not have detailed knowledge of the aircraft other than that obtainable from a study of the normal Passenger Safety Leaflet. The total number of test subjects is not critical but they should be adults and should include both males and females over 60 years of age.
- 3.8 The precise details of any demonstration should be discussed and agreed with the CAA but should include consideration of the following:

In each demonstration, the test subject acting alone and without any assistance should be able:

- a) to leave the seat or seat row and enter the cabin aisle;
- b) standing or stooping in the aisle and making use of the visual reference to the floor proximity marking system, to identify and locate the first exit or pair of exits either forward or aft (where appropriate);
- c) to proceed to the particular exit(s), without significant hesitation or evidence of confusion, making all exit identifications by reference only to visible features not more than 4 feet above the cabin floor.

After each test, the test subject should indicate to the observers the means by which the exit was located.

- 3.9 A sufficient number of tests should be performed to ensure that, at least, one exit of each type in the passenger cabin has been identified with the exit both open and closed using the associated marking systems. (Safety precautions should be taken particularly for any demonstration involving open exits).

Leaflet 33-20 Installation of High Intensity Strobe Lights (HISL) on Helicopters

1 Introduction

The purpose of this Leaflet is to provide information and guidance on the requirements for approval of HISL installations. This information does not represent official European Aviation Safety Agency (EASA) policy. However, the information presented in this Leaflet has been used by the UK CAA and is considered to be useful guidance material for the evaluation of HISLs on helicopters.

2 References:

JAR OPS 3 Commercial Air Transport (Helicopters)

Commission regulation No (EC) 1702/2003 Annex Part 21 – Certification of aircraft and related products, parts and appliances, and of design and production organisations

CS-27 – Certification Specification for Small Rotorcraft

CS-29 – Certification Specification for Large Rotorcraft

CS-VLR – Certification Specification for Very Light Rotorcraft

BCAR Section G6-7

AC 27-1B, Chg 1 Certification of Normal Category Rotorcraft

AC 29-2C, Chg 1 Certification of Transport Category Rotorcraft

CAP 393 Air Navigation: The Order and The Regulations

CAA Letter Captain J G Mimpriss dated 2 July 1991

3 Background

- 3.1 The UK Air Navigation Order Rules of the Air 1996 (Rules 9 and 10) require the mandatory fitment of an anti-collision light on certain classes of helicopters. They are helicopters having a maximum total weight authorised (MTWA) of more than 5700 kg and those having a MTWA of 5700 kg or less which conform to a type first issued with a type certificate on or after 1 April 1988. The Joint Aviation Requirements JAR-OPS 3, Commercial Air Transport (Helicopters), also requires that a helicopter operated in day VFR conditions shall be equipped with an anti-collision light system. Anti-collision lights may be fitted on other helicopters as an option.
- 3.2 The EASA Certification Specifications for aircraft are used to demonstrate compliance with the Basic Regulation (Regulation 216/2008) and its implementing rules (Regulation 1702/2003). These include airworthiness codes, which are standard technical interpretations of the airworthiness essential requirements contained in Annex 1 to the Basic Regulation; and acceptable means of compliance, which are non-exclusive means of demonstrating compliance with airworthiness codes or implementing rules.
- 3.3 The Certification Specifications for small rotorcraft and large rotorcraft (CS-27 and CS-29) include paragraph 1401, which requires that an anti-collision light system be

installed if the rotorcraft is to be operated at night. CS-VLR requires that if an anti-collision light system is fitted, it complies with CS-27.1401.

- 3.4 The Advisory material for paragraph 1401 states that certification for a night operation requires an approved aviation red anti-collision light. Determination of the location and how many anti-collision lights are required to satisfy the regulations are functions of aircraft shape and the ability to obtain the required area coverage and light intensity.
- 3.5 In addition, the Advisory material states that the anti-collision light(s) should be located to obtain the required coverage and to prevent cockpit reflections that would affect the crew's vision. The anti-collision lights are required to be red to reduce cockpit reflections and objectionable effect of rotor blade strobe effects.
- 3.6 The UK Air Navigation Order Rules of the Air define 'anti-collision light' as meaning, in relation to a helicopter, a flashing red light. They also require that an anti-collision light, when fitted, must be switched on in flight. In order to improve conspicuity however, the CAA has been requested to approve HISL units with a dual colour (red/white) capability. For daytime use the unit could be switched to flashing white and for use at night, flashing red. As the Rules of the Air require helicopters to display a flashing red light by night and day, the UK CAA issued a general exemption to Rule 9 (1) (b) in relation to these units for daylight use.
- 3.7 In response to concern expressed over the number of near collisions between low flying military aircraft and helicopters engaged on pipe or powerline survey, the CAA is to require the fitment of HISLs on these helicopters since 30 June 1992. CAA letter entitled 'High Intensity Strobe Lights for AOC Helicopters Engaged in Power and Pipe Line Survey Operations' dated 2 July 1991 refers.
- 3.8 This Leaflet summarises the requirements applicable to the fitment of flashing white or white/red HISLs on helicopters when fitted to improve daytime conspicuity.

4 General

- 4.1 The fitment of a HISL to a helicopter, whether in compliance with CAA requirements or not, will be classified as a major design change in accordance with EC Reg. 1702/2003 Annex Part 21A.97. It could normally be expected that this be introduced using Part 21 Subpart E, STC process, although Part 21 Subpart D for the TC process would be equally appropriate. The major design change application may only be submitted by the holder of the type certificate, for changes under Part 21 Subpart D; or by a person or organisation holding a design organisation approval in accordance with Part 21 Subpart J or equivalent agreed by the EASA. Part 21 paragraphs 21A.92, 21A.97, 21A.112, 21A.112B refer.

The major change will include the approval of the equipment; the responsibility for the equipment design would therefore be vested in the design organisation making the design change application.

- 4.2 For the purpose of improving the conspicuity of helicopters in daylight conditions, the minimum intensity of a white strobe light for it to be effective is considered to be 2000 candela. Anything less powerful will not provide an effective and easily discernible contrast against ambient sunlight and light coloured backgrounds. Therefore in the context of helicopters undertaking pipe and powerline survey operations, HISLs are considered to be those of 2000 candela or more. The intensity of other HISLs, fitted as optional equipment for other types of operations, may be chosen at the discretion of the applicant.

5 Effective Flash Frequency

- 5.1 The effective flash frequency is the frequency at which the HISL or HISLs are observed from a distance. The frequency applies to all sectors of light including the overlaps which might exist when the system consists of more than one light source.
- 5.2 The effective flash frequency of the light shall be not less than 40 and not more than 100 flashes per minute. In an overlap, flash frequencies of up to 180 flashes per minute will be permitted.

6 Coverage

When performing the functions of an anti-collision light, as required by the UK Air Navigation Order Rules of the Air, the HISL shall be visible in all directions within 30° above and 30° below the horizon. When fitted as an additional light in order to enhance conspicuity, the field of coverage should be as great as is practically possible when taking into account the limitations of installation weight, centre of gravity and structure. It is not expected that two HISL (upper and lower) need to be fitted to meet the UK CAA requirements relating to power and pipeline survey operations.

7 Design Considerations

- 7.1 Strobe light units normally operate by charging a capacitor to a high voltage and then discharging through the flash tube. Extra care is therefore necessary to ensure that there is no hazard to personnel from the high voltage, particularly if the capacitor is remote from the light fitting. Also the helicopter should be checked to ensure that the discharge of the tube causes no interference to any equipment and systems required for type certification or by the operating rules, or whose improper functioning would reduce safety. Special consideration should be given to cases where the unit is mounted close to an existing aerial. Care should be taken in the location of the discharge unit and in the routing of high voltage cables to ensure that they are not in close proximity to, or liable to be a source of ignition to, flammable fluids or vapours. All fittings should be adequately bonded. Fittings and wiring should be installed to ensure they can withstand the effects of lightning discharge.
- 7.2 The HISL, if fitted in addition to a standard red anti-collision light, must have a separate control switch which is independent from the red anti-collision light control.
- 7.3 The HISL must be positioned so as not to be a source of any interference to the pilot i.e. no distracting glare or reflection. This will primarily be achieved by careful positioning of the HISL but may involve the treatment of any reflecting surfaces.
- 7.4 Unless operation of the HISL has been evaluated and found not to be a source of distraction in these particular circumstances a cockpit warning placard shall be situated on the pilot's instrument panel stating:

WARNING – Turn off the white strobe light when in the vicinity of other aircraft or persons when on the ground, during flight in cloud, fog or haze and during night operations.

8 Flight Manual

As part of the major change, a Flight Manual Supplement shall be raised which states operating limitations and normal operating procedures associated with the HISL installation. A specimen Flight Manual Supplement is shown as Annex A.

9 Electrical Load Analysis

The electrical load analysis shall be amended, as appropriate.

10 Approval Procedures

The major change shall be approved in accordance with European Commission Regulation (EC) No. 1702/2003 Annex Part 21 Subparts D or E.

Annex A
Issue 1
SPECIMEN – FLIGHT MANUAL SUPPLEMENT

[Company ABC] Flight Manual Supplement No [X]

[Aircraft Type]

Manufacturer's Serial No:

Registration Mark:

The information contained herein supplements or supersedes the basic manual only in those areas listed in this supplement. For limitations, procedures, and performance information not contained in this supplement, consult the basic manual.

Introduction

[Company ABC] Modification No [XYZ] introduces a HISL installed at the [aircraft position]. The HISL emits a flashing white light at an intensity of [at least 2000 candela]. Pilot operation of the HISL is through a switch located [cockpit position].

Limitations

A cockpit warning placard is situated on the instrument panel stating:

WARNING

Turn off the white strobe light when in the vicinity of other aircraft or persons on the ground, during flight in cloud, fog or haze and during night operations.

Emergency Procedures – No Change

Normal Procedures

After Take-off

When clear of persons on the ground: HISL switch – ON

Before Landing

HISL switch – OFF

Performance – No Change

To be inserted at the back of the manual and the CAA revision record sheet amended accordingly.

[Company ABC] Supplement No [X]

CAA Approved

[Date]

INTENTIONALLY LEFT BLANK

Chapter 34 Navigation

Leaflet 34-10 Compass Base Surveying

1 Introduction

In carrying out a swinging procedure for direct-reading and remote-reading compasses, the primary object is to determine the deviations caused by the magnetic field components of an aircraft. It is, therefore, necessary for swinging to be undertaken at a location where only these aircraft field components and the earth's magnetic field can affect the readings of compasses. The location must be carefully chosen and surveyed to prove that it is free from any interfering local magnetic fields and also to establish it as the base on which all aspects of swinging procedures are to be carried out. The effect of interfering fields is to cause distortion of the direction and intensity of the earth's field. The effects on direction are the most critical and therefore, it is necessary for these to be determined during a survey. Any significant effects on the horizontal intensity will be detected as a change in direction, if suitable procedures are employed. The purpose of this Leaflet is to outline the basic requirements of a compass base, to define the accepted base classifications and also to outline the procedures which may be adopted for surveying selected locations.

- 1.1 The CAA does not carry out surveys or approve compass bases, but its interest in surveying procedures lies in the fact that the accuracy of a base is a significant factor in meeting British Civil Airworthiness Requirements relevant to the overall accuracy of compasses installed in aircraft. Surveys may be carried out by an operator or by an airport authority and in this connection, the standards set by QinetiQ, formerly the Ministry of Defence agency Defence Evaluation & Research (DERA), are recognised by the CAA. QinetiQ has the responsibility under the MOD's Long Term Partnering Agreement for surveying compass bases for military aircraft world wide, where the UK MOD have an interest, in addition to this QinetiQ also provides a technical and scientific advisory service to the MOD on all aspects of compass bases and compass calibration and testing. All aspects of these services can be commercially contracted by airline operators and airport authorities by contacting QinetiQ:

QinetiQ ix TECS Project Manager
Land Magnetic Facilities
Portland Bill
Portland
Dorset
DT5 2JT
UK

Tel. +44 (0) 1305 86 2038 or +44 (0) 1305 86 2000
Fax. +44 (0) 1305 86 2001

2 Base Requirements

A compass base must meet the following minimum requirements:

- a) It must be accessible, reasonably level in all directions and its use should not interfere with normal aircraft movements on the airport.
- b) It must be free from magnetic fields, other than that of the earth, which might cause aircraft compass errors. Most surface causes of errors are obvious, i.e. buildings and installations containing ferromagnetic components such as wire fences, drain and duct covers, picket points and lighting installations. The most likely underground causes of magnetic interference are:
 - i) Buried scrap metal and old brickwork.
 - ii) Reinforced concrete.
 - iii) Pipelines including drainage systems.
 - iv) Magnetic soil and rocks.
 - v) Electrical cables, conduits and airfield lighting transformers.
 - vi) Ferromagnetic pipes.

If such items are found at the selected location they should be removed if possible. Even though the area may be within permitted maximum limits of deviation (see paragraph 3) it is recommended that any ferromagnetic material present should still be removed as its magnetic effect may change with time and thereby downgrade the accuracy of the base. Where electrical cables cannot be avoided, their effects, with and without current flowing, must be checked at intervals along their length, especially around known joints. If a new base is being manufactured great care must be taken to ensure that the area is not magnetically contaminated after survey and during manufacture. Steel reinforcing must obviously be avoided and any aggregate or hardcore used in the foundations must not be magnetic or contain magnetic items such as steel wire or drums, bricks, boiler clinker, blast furnace slag or magnetic rock. All steel shuttering and associated pins used when laying concrete must be removed. On completion of all work a full survey must be repeated.

- c) A base should be sited so that its datum circle (see paragraph 2 f) iii)) is at least 46 metres (50 yards) away from hangars and other steel-framed buildings and at least 91 metres (100 yards) away from buildings containing electrical power generation and distribution equipment and also from overhead or underground power cables.

NOTE: Proposed building programmes should be examined to ensure that the site is not scheduled for other work.

- d) A base must be large enough and of such load-bearing strength as to take all types of aircraft for which it is likely to be used. In this connection, some important factors to be considered are:
 - i) Whether an aircraft will be towed or taxied during the swing.
 - ii) The radii of the turning circles of the aircraft.
 - iii) The position of sighting rods and target fixtures on the aircraft and their likely path during the swing.
 - iv) The likely positions of flux detector units of remote-reading compass systems.
- e) The surface of the base should not preclude its use in wet weather.

- f) The base should be clearly and permanently marked to show:
 - i) The base centre.
 - ii) The central area in which a direct-reading compass, or flux detector unit of a remote-reading compass system, should remain during the swing.
 - iii) The datum compass circle, i.e. the circle around the central area showing where the datum compass should be placed.
 - iv) Areas of magnetic anomalies which cannot be removed.
 - v) Nose wheel turning circles.
 - vi) If the base is to be used for carrying out 'electrical' swings a North-South line should be painted on the base, together with markings to indicate the locations of the compass calibrator monitor and turntable and the bearing of the reference target used when sighting the monitor (see also paragraph 5.6).

NOTE: Paint is the best medium for marking concrete. The datum compass circle, which may be on grass, must be marked permanently with a narrow continuous path of non-magnetic material such as tarmac or gravel.

3 Base Classifications

Compass bases may be established as either Class 1 or Class 2, the difference between them being only in the limits of permitted maximum deviation to be found anywhere within the base area as follows:

- a) **Class 1.** The maximum permissible deviation is $\pm 0.1^\circ$. Bases of this accuracy are required for carrying out refined swings, e.g. swinging of aircraft in which remote-reading compasses are used as magnetic heading reference systems, in conjunction with such equipment as Doppler Systems.
- b) **Class 2.** The maximum permissible deviation is $\pm 0.25^\circ$. Bases of this accuracy are suitable for carrying out standard swings, e.g. swinging of aircraft in which the primary heading reference is provided by a remote-reading compass system, with a direct-reading compass serving as a standby.

NOTE: A location, the permissible deviation of which is greater than $\pm 0.25^\circ$ may be used where a direct-reading compass is used as the primary heading reference (see paragraph 5.5).

4 Types of Survey

The following types of survey are normally carried out to assess the suitability of a location at which a compass base is to be finally established:

- a) **Initial Survey.** This is the first assessment survey of a location to determine gross errors and should be carried out by the aircraft operator or airport authority but, where appropriate, it is recommended that the certified services of QinetiQ be contracted (see paragraph 1.1). If the deviations obtained appear to be within the permissible limits laid down for Class 1 and Class 2 bases there is justification for carrying out an establishment survey.

- b) **Establishment Survey.** This survey is of a more detailed nature in that measurements are taken at a greater number of more closely spaced points. The survey may also be carried out by the aircraft operator or airport authority, but, where appropriate, it is recommended that the certified services of QinetiQ be contracted (see paragraph 1.1).
- c) **Periodic Re-survey.** After a base has been established a detailed re-survey must be carried out at the following intervals, in order not to compromise QinetiQ:
 - i) Class 1, every 5 years.
 - ii) Class 2, every 2 years. In addition, bases of this accuracy should, where possible, be surveyed by QinetiQ every 6 years.
- d) **Annual Check.** All bases should be checked annually to ensure that markings and boundaries are clearly defined and that no work has been done which might affect their magnetic properties and also to take into account changes in magnetic variation. If any doubt exists, the suspect area should be given a detailed magnetic survey.
- e) **Area Survey.** An area survey (see paragraph 5.6) is normally confined to the selection of a location which is to be used for carrying out a more specialised form of compass calibration procedure known as an 'electrical' swing.

5 Survey Methods

There are two principal methods which may be adopted for the surveying of a compass base:

- a) the reciprocal bearing method (see paragraph 5.3), and
- b) the distant bearing method (see paragraph 5.4). In both methods, the use of accurate magnetic bearing compasses of either the medium landing type or the high-precision datum type will be required to determine the effects of interference from local magnetic fields. There is also a third surveying method (see paragraph 5.5), but being of a lower order of accuracy its adoption should be strictly limited. For the area survey referred to in paragraph 4 e) units of a specially designed compass calibrator set are used (see paragraph 5.6).

5.1 Checking and Correction of Survey Instruments

Before carrying out a survey the appropriate survey instrument(s) should be given the full serviceability checks prescribed in the relevant operating manual, paying particular attention to checks which affect the repeatability of readings, e.g. pivot friction. Reference should also be made to any associated instrument test certificates to ascertain any instrument errors requiring correction. When the reciprocal bearing method (see paragraph 5.3) is used, bearings should be taken on a distant object with both compasses to establish a correction which can be applied to every reading taken from one of the compasses.

5.2 Positioning of Survey Instruments

In order that the deviation limits of a chosen location may be accurately assessed for base classification purposes from an establishment survey, the survey instrument(s) should be set up at close regular intervals, e.g. every 6 metres (20 feet), to cover the area quadrant by quadrant. The instrument(s) should be at the maximum height of its tripod which is approximately 1.5 metres (5 feet). In most types of aircraft, direct-reading compasses and flux detector units of remote-reading compasses are above this height. If a base is also to be used for an aircraft the compasses and detector

units of which are below 1.5 metres (5 feet), assessment should then be made closer to the ground.

NOTE: At certain stages of an area survey procedure, assessments are made with the tripod set at both minimum and maximum heights (see paragraph 5.6).

5.3 Reciprocal Bearing Method

This method is the most accurate and may be adopted for an initial assessment survey, a detailed establishment survey and a periodic re-survey. It requires the use of two precision datum compasses, one being designated the master compass and the other the mobile compass. The procedure is as follows:

- a) Following the checks for serviceability, both compasses should be aligned to a common magnetic datum. This is done by setting them up, in turn, on a tripod positioned as near to the anticipated centre of the base as is practical and sighting the compass on a distant object and noting, for each compass, the average of several determinations of the magnetic bearing. This produces the correction referred to in paragraph 5.1 which is subsequently applied to the readings of the mobile compass. Frequent checks on the accuracy of this correction should be made throughout the subsequent stages of the survey procedure.
- b) The master compass and tripod should be kept in its original position and the mobile compass and its tripod should be positioned at various points around the area to give good coverage (see paragraph 5.2). At each point, the two compasses are aligned on each other's sighting telescope object lenses.
- c) When the compasses are aligned, bearings should be taken from the bearing plates of the compasses and the magnetic deviation between the two compass positions should be obtained by taking the difference between bearing plate readings and subtracting 180° . The sign convention used for the deviation is that, if the reading of the mobile compass is greater than that of the master compass, the deviation is negative. Conversely, the deviation is positive if the master compass reading is greater than that of the mobile compass.
- d) The deviations should be recorded on an observation log, which should take the form of a scaled diagram of the area. The positions of any objects in the area such as drains, cable duct covers, lights, picketing points, etc., should also be indicated on the log. Areas in which deviations are in excess of the limits permitted by the appropriate base classification, should be investigated and, where possible, the source of magnetic interference should be eliminated. Where magnetic interference cannot be eliminated the area should also be indicated on the observation log as a prohibited area, i.e. an area which must be avoided when positioning an aircraft and datum compass for the purpose of swinging.
- e) Care should be taken to ensure that there are no obvious magnetic objects near the chosen centre of the base. If the deviations are such that their mean is more than half the deviation limits for the class of base being surveyed, it should be assumed that there is a buried object near the base centre.

5.4 Distant Bearing Method

This method should be used only for initial surveys and for gross error checks of Class 2 bases carried out because of doubts raised during annual checks. The procedure to be adopted is as follows:

- a) Select a distant object at least 2 nautical miles away and accurately locate its position and the position of the compass base on a larger scale map and measure the distance between them. Mark the line of sight from the centre of the compass base to the distant object.

- b) Calculate the angular correction to be applied to bearings taken away from the base centre using the formula:

$$\text{Correction Angle} = \frac{\text{Lateral distance from line of sight} \times 180^\circ}{\text{Distance to the object} \times \pi} \quad \text{Degrees}$$

- c) After ensuring that there are no objects in the area of the base centre likely to have a magnetic influence, the bearing compass, which may be of the medium landing type or precision datum type, should be set up and a datum bearing obtained by measuring the bearing of the distant object.
- d) Take bearings of the distant object from selected points around the base area and after applying the calculated corrections, compare the bearings with the datum bearing. Any difference obtained will be due to deviations present, assuming that the base centre is free from deviation. The deviations should be recorded on an observation log (see paragraph 5.3 d)).

5.5 Surveying Pole Method

This method is simpler than those already described and requires the use of two poles similar to those used by a land surveyor and in addition, a medium landing compass. Its survey accuracy is, however, of a lower order, principally because it does not utilise magnetic bearings of distant objects as a datum. The use of this method should, therefore, be restricted to the surveying of locations at which deviation limits outside those permitted under Class 1 or Class 2 (see paragraph 3) are acceptable; for example, a location for swinging aircraft using direct-reading compasses as the primary heading reference. It may also be used in such cases as the initial assessment of gross errors prior to a detailed establishment survey of a base and where, in the absence of an established Class 1 or Class 2 base or more accurate surveying equipment, a swing is necessary to enable an aircraft to undertake a positioning flight. The procedure for carrying out this method is as follows:

- a) One surveying pole should be placed in the centre of the area chosen and the medium landing compass should be positioned and levelled 9.1 metres (30 feet) to the south of the pole. A plumb bob should be suspended from the centre of the compass to the ground and the sighting device should be set to read due North. The second pole should be positioned 9.1 metres (30 feet) to the North of the centre pole, so that, when viewed with the compass sights as set, the two poles are in alignment.
- b) The plumb bob position should be marked with a peg or a painted mark and the position of the second pole and the compass should be interchanged. The compass reading with the poles as now positioned should be checked and should be within $\pm 1^\circ$ of the reciprocal of the initial reading.
- c) A further check should be made by moving and sighting the compass along a line between the North and South points already obtained, taking at least four readings at approximately equidistant intervals. The compass should not deviate by more than 1° from the original reading at any position.
- d) The same procedure outlined in paragraphs a), b) and c) should be followed for determining the East and West positions.
- e) The geometric location of the cardinal points should be proved by checking the chord distances between the points, as indicated by pegs or painted marks. If they are equal then the North-South and East-West lines are at right angles. In any case, the measurements should agree within ± 76 millimetres (3 inches).

- f) The whole of the foregoing procedure should be followed for determining deviations in the inter-cardinal areas and in the area around which the compass is to be positioned during the swinging procedure.

5.6 Area Survey

This survey is carried out using the monitor and console control units of a compass calibrator set which is also designed for the 'electrical' swinging of remote-reading compass systems. In this type of survey the principal objectives are

- a) to determine the direction and strength of the earth's magnetic field at the locations of aircraft flux detector units (detector unit location check);
- b) to select the point at which the compass calibrator monitor unit should be located in order to carry out an 'electrical' swing (monitor location check), and
- c) to mark out the monitor and turntable location points and also a North-South line over which an aircraft must be positioned during a swing. The full setting-up procedures and operating instructions are detailed in the calibrator operating manual and reference to this document should, therefore, always be made. The information given in the following paragraphs is for general guidance only.

5.6.1 Detector Unit Location Check

The purpose of this check is to determine the uniformity not only of direction, but also the strength of the earth's field at points of the compass base which will correspond to the locations of detector units, e.g. in the vertical stabiliser, or wing tips of an aircraft. The strength of field is determined in order to obtain certain voltage values which must be set up in the calibrator control console unit, during an 'electrical' swing procedure, to simulate the earth's field. The monitor and console control units are electrically interconnected by the appropriate cables and are set up within 3 to 4.6 metres (10 to 15 feet) of each other. Magnetic direction and strength is measured in both the vertical and horizontal planes.

- a) Measurements in the vertical plane are taken with the monitor mounted on its tripod, adjusted firstly to the minimum height position and then to the maximum height position. Direction is determined in each position of the tripod by setting the monitor on each of the four cardinal headings and noting the difference between these headings and the headings recorded on the control console unit. The average of the errors (the algebraic sum divided by four) is recorded as the monitor index error. The difference between the index errors at the minimum and maximum height positions is then calculated. If the difference exceeds the specified value (6 minutes is a typical value) the area surveyed is unsuitable. Field strength is determined at the minimum and maximum height positions of the monitor tripod, by setting the monitor to a heading of zero degrees and obtaining voltage values from settings made on the control unit.
- b) Measurements in the horizontal plane are carried out to determine the uniformity of the earth's field direction and strength over a circle of 1.5 metres (5 feet) radius, the centre of which is at the location of the flux detector unit on the aircraft. The readings are taken at the centre of the circle with the monitor tripod at its normal operating height and with the monitor set, in turn, on each of the four cardinal headings. The differences between monitor and control console unit headings are then noted and a monitor index error obtained in the same manner as that described in a). Readings are then taken on the cardinal headings with the monitor and tripod positioned, in turn, at four equidistant points on the perimeter of the circle and corresponding monitor index errors are obtained. The algebraic difference between these errors and the index error at the centre of the circle is

then calculated and should be within the limits ± 6 minutes. Field strength is determined by setting the monitor to a heading of zero degrees and obtaining voltage values with the monitor at the centre of the circle and at the four equidistant points on its perimeter.

5.6.2 Monitor Location Check

The purpose of this check is to select the location for the monitor in order to measure the earth's field during the 'electrical' swinging procedure. The location selected should be such that with an aircraft positioned on the base, the monitor readings will not be influenced by magnetic effects of the aircraft itself. A distance of 23 to 30 metres (75 to 100 feet) is normally sufficient. The direction and strength of the earth's field is determined at the selected location and corresponding monitor index error and voltage values, calculated. The bearing of a reference target at least 800m (one-half mile) distant from the location is also obtained. As this target is to be used during a compass swing it should be ensured that it will be visible from the monitor location when an aircraft is positioned on the base. The suitability of the selected monitor location is then determined by re-positioning the monitor at the flux detector unit location and measuring the direction and strength of the earth's field and then calculating the algebraic difference between values at each location. The readings at each location should be taken within a time of 30 minutes of each other to lessen the possibility of a change in the earth's field.

5.6.3 Marking of Base

On completion of the foregoing checks, markings must be permanently set out on the base to indicate the following:

- a) **Location of Flux Detector Units.** For aircraft the flux detector units of which are installed in the vertical stabiliser, the marking is made on the North-South line (see c)) and for aircraft the flux detector units of which are installed in each wing tip, the markings are made each side of the North-South line at distances corresponding to those from the aircraft centre line.
- b) **Location of Monitor.** In addition to this marking, the bearing of the reference target used during the survey should also be marked at the monitor location.
- c) **North-South Line.** This line should be marked out from a point which is used as a reference in determining the flux detector unit location. The monitor is set up over this point and by lowering the monitor telescope so that its graticules are observed against the base, several other points are marked out; firstly, with the monitor on a corrected zero degree heading and then on a heading of 180° degrees. The points are then joined by a painted line.

Leaflet 34-20 Compasses

1 Introduction

This Leaflet gives general guidance on the installation of compasses which are used as either primary or standby heading indicators, and also on the methods of compensating for deviation errors. Brief details of the operating principle of compasses are also included, but as there are so many variations in application to systems in current use, such details are only of a fundamental nature. It should be read in conjunction with Leaflet 34-10 Compass Base Surveying, relevant compass and aircraft Maintenance Manuals, and approved Maintenance Schedules/ Programmes.

1.1 Contents

Paragraph

1	Introduction
2	Direct Reading Compasses
3	Compass Errors And Methods Of Compensation Of Direct Reading Compasses
4	Remote-Reading Compass Systems
5	Compass Errors And Methods Of Compensation Of Remote Reading Compass
6	Compass Location
7	Inspection And Tests Before Installation
8	Installation
9	Preparation Before Swinging
10	Aircraft Sighting Points
11	Compass Swinging Area
12	Compass Swinging Procedure (Direct Reading)
13	Compass Swinging Procedure (Remote Reading)
14	Compensating And Recording
15	Compass Swinging In Service
16	Routine Inspection

1.2 Deviation is the angular difference between magnetic and compass headings, and is caused by magnetic influences in or near the aircraft. It is called Easterly (positive deviation) or Westerly (negative deviation) dependent on whether the North-seeking end of the magnet system is deflected to the East or the West of the magnetic meridian.

1.3 The technique of deviation compensation is known as 'swinging' and consists of:

- a) observing the relevant compass system indicator readings on different headings of the aircraft,
- b) calculating the deviation errors and determining coefficients,
- c) neutralising the aircraft's magnetic fields by adjustment of compensator devices, and
- d) recording any residual deviations on a deviation or 'Steer-by' card.

NOTE: This Leaflet describes one of the methods used for swinging, calculating deviations and applying corrections. There are other procedures in use which adopt different calculation sequences.

2 Direct Reading Compasses

There are two types in use, the card type and the grid-steering type. The major differences between the two are in the magnet system arrangement, the method of heading presentation and the arrangement of the deviation compensator devices.

- 2.1 Card type compasses, which are designed for mounting on an instrument panel or on a coaming panel, indicate magnetic headings by means of a graduated card affixed to the magnet system and registering against a lubber line in the front of the bowl. The deviation compensator device is usually secured directly to the compass bowl.
- 2.2 Grid steering type compasses, employ a needle and filament type magnet system which is referenced against a grid-ring located over the compass bowl. The grid-ring, which may be rotated and clamped in any position, has a graduated scale and two pairs of parallel grid wires in the form of an open T. Magnetic headings are indicated by the number of degrees read against a lubber line in the compass bowl, when the needle and filaments lie parallel to the grid wires, and the North-seeking filament points to the North mark on the grid ring. These compasses may be designed for mounting on a bracket below an instrument panel or for inverted mounting in a cockpit roof. In the latter case, heading indications are observed by means of a mirror attachment. Deviation compensator devices are normally separate and are mounted on the compass supporting bracket.

3 Compass Errors and Methods of Compensation of Direct Reading Compasses

In connection with the compensation of direct-reading compasses, the following principal errors have to be taken into account:

- a) **Index Error.** This error, which is also known as Coefficient 'A' error, results from misalignment of a compass in its mounting and has the same magnitude on **All Headings**. The error is calculated by averaging the algebraic sum of the deviations on each of the cardinal and quadrantal headings. Compensation is effected by rotating the compass in its mounting through the number of degrees calculated, and relative to the longitudinal axis of the aircraft.
- b) **One-cycle Errors.** These refer to the deviations produced in compass readings as a result of the effects of components of permanent or hard-iron magnetism of the aircraft's structure. The deviations vary as sine or cosine functions of the aircraft's heading, the maximum deviations being termed Coefficients 'B' and 'C' respectively. Other sources of these errors are components of soft-iron magnetism induced by the earth's field, the hard iron itself, and the effects of

electric currents from cables or equipment which may be mounted in the vicinity of the compass.

The Coefficient 'B' error is calculated by averaging the algebraic difference of the deviations on the East and West headings, while the Coefficient 'C' error is calculated by averaging the algebraic difference of deviations on the North and South headings. Compensation is effected by a permanent magnet type compensator unit, which, depending on the type of compass, is either secured direct to the compass bowl or is mounted separately on the compass support bracket. The unit contains two pairs of magnets, the axes of which are so disposed that their fields neutralise the effects of the magnetic components producing 'B' and 'C' deviations. Each pair of magnets can be rotated by a shaft provided with either a screwdriver slot or a shaped end requiring the use of a key.

4 Remote-Reading Compass Systems

The principal component of any system is a flux detector unit, sometimes called a flux valve or fluxgate. It is located in an area relatively free from any disturbing magnetic fields of the aircraft itself (e.g. a wing tip or vertical stabiliser) so that the horizontal component of the earth's magnetic field can be more accurately detected by the sensing element within the unit. The sensing element forms part of a synchro type of transmission system which, in most compasses, is coupled to a horizontal-axis directional gyro contained within either a heading display indicator mounted on the main instrument panel, or a master gyro unit from which heading data is transmitted to a separate indicator. In some aircraft using an inertial navigation system, the flux detector sensing element is connected to a compass coupler unit instead of a directional gyro, the purpose of the unit being to develop a stabilised magnetic heading reference from both sensing element and inertial navigation system signals. The sensing element is pendulously suspended in such a way that it has a limited amount of freedom in the pitching and rolling planes, but has no freedom in the yawing plane. In one currently used system the element is stabilised by a vertical gyro.

- 4.1 The sensing element is made up of material having high magnetic permeability wound with an exciter or primary coil and three pick-off or secondary coils. The exciter coil is supplied with a low-voltage single-phase a.c. at a constant frequency (typical values are 26 V, 400 Hz) and this produces an alternating flux in the sensing element material. In addition to this flux, the horizontal component of the earth's magnetic field is also introduced; its effect being to change the total flux cutting the pick-off coils in such a manner that an e.m.f. is induced in them which, in terms of amplitude and phase, represents the magnetic heading.
- 4.1.1 The induced e.m.f. causes current to flow to the stator windings of a receiver synchro within either the display indicator, master gyro unit or compass coupler, as appropriate, and a field is set up across the stator in a direction determined by the current flow in windings. If the detector sensing element and receiver synchro are in synchronism, the synchro rotor is in its 'null' position and no signal voltage is induced in its winding by the stator field cutting it. When a change in aircraft heading takes place, however, the position of the detector sensing element with respect to the earth's field also changes with the result that the current flow in the receiver synchro stator changes, causing the stator field to rotate. This, in effect, is the same as a rotor displacement from the 'null' position, and although the rotor itself always tends to rotate with the stator field it is restrained momentarily by the mechanical coupling between it and the gyro. Thus, an error voltage is induced in the rotor winding; the phase and amplitude of which being dependent on the direction and magnitude of

displacement of the rotor from the 'null' position. The voltage is fed to an amplifier and finally to a slaving system which produces a torque to precess the gyro and its indicating element to indicate the heading change. At the same time, the synchro rotor rotates in synchronism with the stator field.

5 Compass Errors and Methods of Compensation of Remote Reading Compass

In connection with the swinging and compensation of remote-reading compasses, the following principal errors have to be taken into account:

5.1 Index Error

This error, which is also known as Coefficient 'A' error, results from misalignment of the flux detector unit and has the same magnitude on All Headings. The error is calculated by averaging the algebraic sum of the deviations on each of the cardinal and quadrantal headings.

5.2 One-cycle Errors

These refer to deviations produced in compass readings as a result of the effects of components of permanent or hard-iron magnetism of the aircraft's structure. The deviations vary as sine or cosine functions of the aircraft's heading, the maximum deviations being termed Coefficients 'B' and 'C' respectively. Other sources of these errors are, components of soft-iron magnetism induced by the earth's field, the hard iron itself, and electric currents from cables or equipment which may be mounted in the vicinity of the flux detector unit. The error due to Coefficient 'B' is calculated by averaging the algebraic difference of the deviations on the East and West headings, while the Coefficient 'C' error is calculated by averaging the algebraic difference of deviations on the North and South headings.

5.3 Two-cycle Errors

These errors result from imperfections in the transmission of heading data and are usually referred to as transmission errors. They can be caused by impedance or voltage unbalance in the flux detector sensing element or in the synchros of the compass system. Another source of two-cycle error is soft-iron magnetism.

5.4 Crosstalk Errors

These errors occur particularly during an 'electrical' swinging procedure (see paragraph 13.2) when the d.c. signals simulating the earth's field are applied. They are caused by different sensitivities of the flux detector unit coils and by unequal air gaps separating the flux collector horns; the overall effect being to produce quadrature components which offset the field from that originally intended.

5.5 Methods of Compensation

Typical methods of compensating errors are described in the following paragraphs:

- a) **Index Error Compensation.** The error to be compensated is calculated from the Coefficient 'A' formula (see 5.1). In the most commonly used method, compensation is effected by rotating the flux detector unit in its mounting through the number of degrees so calculated, relative to a datum parallel to the longitudinal axis of the aircraft. The flux detector unit is rotated clockwise (when viewed from above) for a +A error and anti-clockwise for a -A error. In some compass systems the flux detector is first aligned with the centreline of the aircraft, and the 'A' error is removed by providing an electrical differential by means of a differential synchro between the flux detector unit and its synchro.

- b) **One-cycle Error Compensation.** The errors to be compensated are calculated from the Coefficient 'B' and Coefficient 'C' formulae (see 5.2). Depending on the type of compass system installed, compensation may be effected by one of the methods described in i) and ii):
- i) **Mechanical Methods.** In several types of compass systems, a permanent magnet type compensator unit secured to the top of the flux detector unit. The compensator contains two pairs of magnets, the axes of which are so disposed that their fields neutralise the effects of the magnetic components producing 'B' and 'C' deviations. Each pair of magnets can be rotated by a shaft containing a screwdriver slot, and associated gearing. In one particular type of compass system, mechanical compensation is effected by screws, a metal cam and cam follower; the complete device being incorporated within the compass indicator. For details of this method of compensation reference should be made to the relevant Maintenance Manuals.
 - ii) **Electrical Methods.** Electrical compensation is normally effected by a compensator unit connected to, and located remote from, the flux detector unit. A compensator unit contains two adjustable potentiometers, one for each coefficient. Depending on the compass system installed, the potentiometers can be adjusted to vary either the electromagnetic fields produced in two coils mounted on top of the detector unit, or they can be adjusted to produce the correcting electromagnetic field within the flux detector pick-off coils, by supplying direct current to the coils themselves. In this latter case, the coils have the dual and simultaneous function of picking-off voltages resulting from heading changes and of deviation compensation. In certain types of compensator unit, test points are provided to permit measurement of the d.c. voltages across the two potentiometers.

5.6 Crosstalk Error Compensation

Compensation is effected during an 'electrical' swing procedure, by applying d.c. signals to the flux detector unit coils and generating fields which oppose the quadrature components in the North-South and East-West directions.

6 Compass Location

The location of a compass or detector unit in an aircraft is important and factors such as angle of observation, illumination, vibration, and in particular, the effect of magnetic disturbances, require careful consideration. The location is determined during the aircraft's design stage and should not be altered unless authorised by the Airworthiness Authority.

- 6.1 Compensation may be made for a reasonable amount of permanent magnetism, but variable sources of deviation must be kept distant in order to minimise their effects.
 - 6.1.1 Where practicable, magnetic steel parts, especially movable parts, should not be positioned near the compass.
 - 6.1.2 Electrical cables carrying uni-directional current produce a magnetic effect on the compass magnet system which is governed by the current and distance from the compass. All such cables should be positioned, if possible, at least 2 feet away from the compass. If double pole cables are used (i.e. supply and return cables run closely together) the magnetic effects of the cables are usually insignificant.

- 6.1.3 To minimise the effect on the compass of items of equipment with magnetic fields, such items should not be located closer to the compass than the relevant compass safe distance specified for each item by the manufacturer.
- NOTE:** Compass safe distance is defined as the minimum distance from a compass at which an item of equipment may be located to produce a maximum deviation of 1° under all operating conditions. This distance is measured from the pivot of the compass magnet system to the nearest point on the surface of the equipment.
- 6.1.4 The possibility of magnetic fields generated by electric currents passing through windscreen pillars and frames, or through instrument mountings, should not be overlooked.
- 6.1.5 The effect of modifications to instrument installations, radio installations, electrical control panels or wiring in the vicinity of the compass must be considered, and tests should be made to determine whether any deviation will be caused under operating conditions.
- NOTE:** The most adverse combinations of electrical loads must not cause deviation in excess of 2° (5° for light aircraft).
- 6.1.6 In some instances, particularly in light aircraft, certain components and parts of the structure, e.g. control columns, control arches, tubular frames, may exhibit residual magnetism in varying amounts which cannot be corrected by compass deviation compensating devices. The origin and cause of such magnetism must be investigated and the appropriate remedial action must be taken. A simple practical detection method is to position a small pocket compass near suspect components or parts and to note any deflections of the needle.

7 Inspection and Tests Before Installation

Direct reading Compasses are particularly susceptible to damage in transit and to deterioration during storage. They should be stored in the transit boxes supplied by the manufacturer, and should be handled carefully to avoid shocks which might impair the pivot action or cause other damage. Compasses should not be stored on steel racks or shelves, or in steel cupboards. Each compass should be inspected for serviceability before installation as follows:

- a) The compass glass, anti-vibration devices and all movable or working parts, where appropriate, should be inspected for condition.
- b) In grid steering compasses, the grid-ring locking device should function correctly and the grid-ring should rotate freely when unlocked. The grid wires should be undamaged and the graduations should be legible.
- c) The compass bowl must be free from dents, and the card and liquid must not be discoloured.
- d) The liquid must be free from sediment and bubbles. There should be no sign of leakage from the bowl as indicated, for example, by staining of the bowl exterior.
- e) In compasses in which the deviation compensator devices are built in, the magnet adjusting screws or spindles should be slowly rotated through their full range of movement to check for roughness, 'hard spots' and backlash in the gearing. There should be sufficient inherent friction to prevent disturbance of compensator settings by shock or vibration. On completion of these checks, the compensators should be returned to their magnetic neutral positions as indicated by the alignment of indicator lines or dots engraved on the spindles with their fixed datum marks.

- f) Compasses with integral lighting should be tested to ensure that no deflection of the magnet system is caused when the lighting is switched on.

7.1 **Pivot Friction¹**

This should be checked with the compass in a level position. The magnet system should be deflected through approximately 10° and held for 30 seconds by placing magnetic material near the compass. The magnetic material should then be removed and the settling position of the magnet system noted. The system should then be deflected approximately 10° in the opposite direction, held there for 30 seconds, then released and the settling point noted. The angular difference between the two settling positions should not exceed the limits specified in the relevant manuals. During this test no tapping of the compass bowl is permissible.

7.2 **Damping Test¹**

The magnet system should be deflected with an external magnet through 90° and held for 1 minute. The deflecting force should be removed. The time taken for the magnet system to return through 85° should not exceed the limits specified in the relevant manuals.

7.3 **Defect Rectification**

The rectification of defects, such as might be revealed by the inspections and tests referred to in paragraph 5 may only be undertaken by an organisation approved by the CAA or JAA to carry out such work.

8 Installation

The compass should be so mounted that a line passing through the lubber line and the vertical pivot support is either on, or parallel to, the longitudinal axis of the aircraft. The lubber line in grid steering type compasses should always point forward. With the card type compasses the lubber line faces aft. Compasses provided with adjustment slots and scale for index error (coefficient 'A') correction, should be positioned so that the centre zero mark on the scale is aligned with the datum mark on the compass mounting.

- 8.1 When not integral, the compass deviation compensator device should be mounted as close as possible to the compass, and should be centrally disposed about the magnet system pivot support with the AFT engraving positioned aft.

- 8.2 Brackets, or other forms of compass supporting structure, should be made of non-magnetic materials; this also applies to all nuts, screws, washers and the tools used for mounting.

NOTE: In aircraft employing a direct-reading compass as a standby heading indicator, the instrument is usually installed adjacent to the central support frame of the windscreen panels. In such cases the retaining nuts and bolts used in this frame should also be of non-magnetic material.

- 8.3 The compass deviation or 'steer by' card should be positioned so that it may be easily read during flight.

- 8.4 If the compass has an integral lighting system the wiring should be properly connected to the appropriate terminals. The lighting circuit should then be switched

1. These paragraphs deal only with pre-installation checks on compasses which have passed their schedule of tests. The tolerances given are general and vary in accordance with the type of compass, the compass specification, the latitude at which the test is made, temperature variation and the strength of the earth's magnetic field.

on and a check made to ensure that this does not cause a deflection of the magnetic system.

9 Preparation Before Swinging

A check should be made to see that all airborne equipment is installed in the aircraft. Loose items or tools made from magnetic materials should not be left in the aircraft or carried by the personnel engaged in the swinging procedure. Any detachable cockpit mechanical control locks which might be magnetic should be removed and placed in their flight stowages. Where towing arms and towing vehicles are to be used for manoeuvring the aircraft, their possible magnetic effect should be investigated, and if significant they should be disconnected and moved clear before taking any compass readings.

NOTE: Throughout the serviceability test and other preliminary checks, and also subsequent swinging procedures, it is most important that power supplies to systems be continually monitored to ensure that voltage and frequency values remain constant within their prescribed limits.

- 9.1 Carry out a serviceability test of the system in accordance with the procedure prescribed in the relevant Maintenance Manual.
- 9.2 Ensure that all equipment required for the swing is available, e.g. appropriate datum compass, sighting equipment, test voltmeters and milliammeters, non-magnetic tools for adjustment of deviation compensators, and external power supply equipment.
- 9.3 Where appropriate, landing gear ground locks should be in position and landing gear shock struts should be checked to ensure that they are properly inflated. In some types of aircraft, a landing gear lever latch is employed which is solenoid-operated. The solenoid is normally energised in flight, and since its magnetic field may have an effect on the accuracy of the standby direct-reading compass, it should also be energised during the swinging procedure. Check that brake system pressure is normal for the appropriate type of aircraft.
- 9.4 The flying controls should be in the normal straight and level flight positions when taking the readings, and should then be operated to ascertain that the movements have no adverse effect on the compass readings. Flaps, throttles, etc., should also be set to the 'in flight' positions.
- 9.5 Electrical equipment, e.g. radio, instruments and pitot tube heaters, should be switched on to ascertain that there are no adverse effects on the compass. In this connection, reference should always be made to the relevant aircraft manuals for details of the electrical loads to be selected appropriate to the aircraft operating conditions, e.g. normal day or night operation, or operation with emergency power.
- 9.6 Deviation compensator devices should be set to their magnetic neutral positions after installation, or after replacement of a compass or deviation compensator device where this is a separate unit.
- 9.7 Obtain appropriate clearance to tow the aircraft to the compass base.

10 Aircraft Sighting Points

In all swinging procedures it is necessary to determine the position of the longitudinal axis of the aircraft with respect to a magnetic heading reference datum, and for this reason, two datum points on the aircraft (e.g. the aircraft nose and tip of the vertical

stabiliser) and directions from which they are to be sighted, must be carefully selected. If the datum points are at different heights above the ground, and if the aircraft is rolled out of a level plane as a result of the compass base not being level, then an error can occur in the measured datum heading. In several types of large transport aircraft, sighting is facilitated by the provision of sighting devices which are attached to the aircraft prior to carrying out the appropriate swinging procedure. Some examples are described in the following paragraphs.

10.1 **Sighting Rods**

In this example, front and rear sighting rods are attached to corresponding points provided along the centre line at the underside of the fuselage. An extension rod is also provided for attachment to either the rear sighting rod, if datum compass sightings are to be taken from the front of the aircraft, or the front sighting rod, if sightings are to be taken from the rear.

10.2 **Telescopic Target Fixture**

- a) A typical fixture is shown in Figure 1. It is attached to the bulkhead of a main landing gear wheel well so that the scale and cross hair are on the inside of the turning circle of the aircraft. The setting of the fixture with respect to the longitudinal axis of the aircraft, is determined by sighting the telescope on a target mark located at the underside of the front fuselage, in this case at the forward jack pad position. The scale is of the centre-zero type, angles to the right being positive and angles to the left being negative, when sighted from the datum compass. Magnetic heading of the aircraft is determined during the swinging procedure by sighting the datum compass on the crosshair and scale of the target fixture, and calculating the difference between the scale reading and the datum compass reading, the latter being the bearing of a pre-selected reference target located at some distance from the base.
- b) Another example of a target fixture is shown in Figure 2. In this case the fixture is attached to the underside of the front fuselage, and its telescope is sighted on a target ball mounted on a cable, the ends of which are secured to the up-lock rollers of each main landing gear strut. When the cable is in position, the ball is situated to the left of the aircraft centreline. Magnetic heading of the aircraft is determined in a similar manner to that described in a).

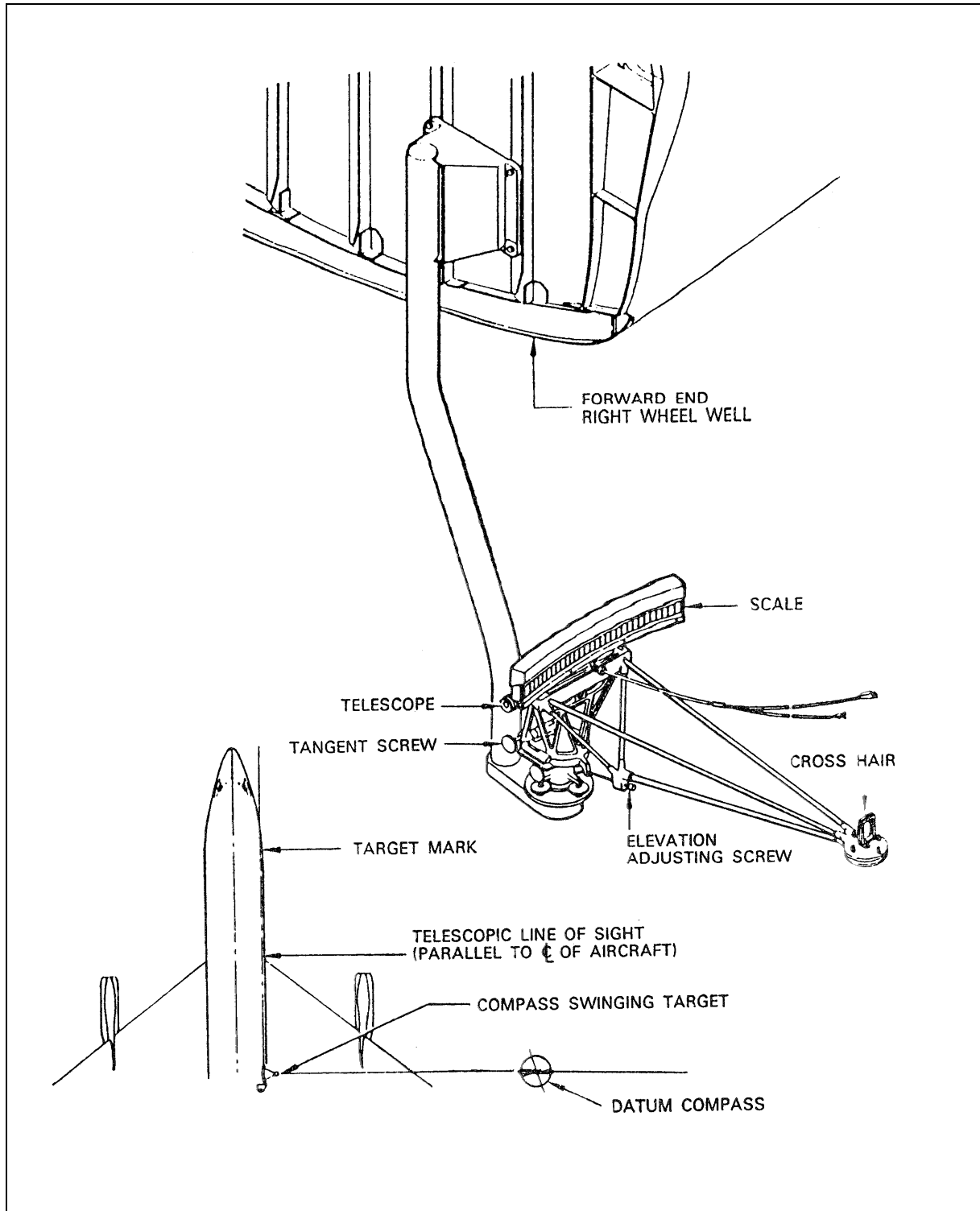

Figure 1 Telescopic Target Fixture

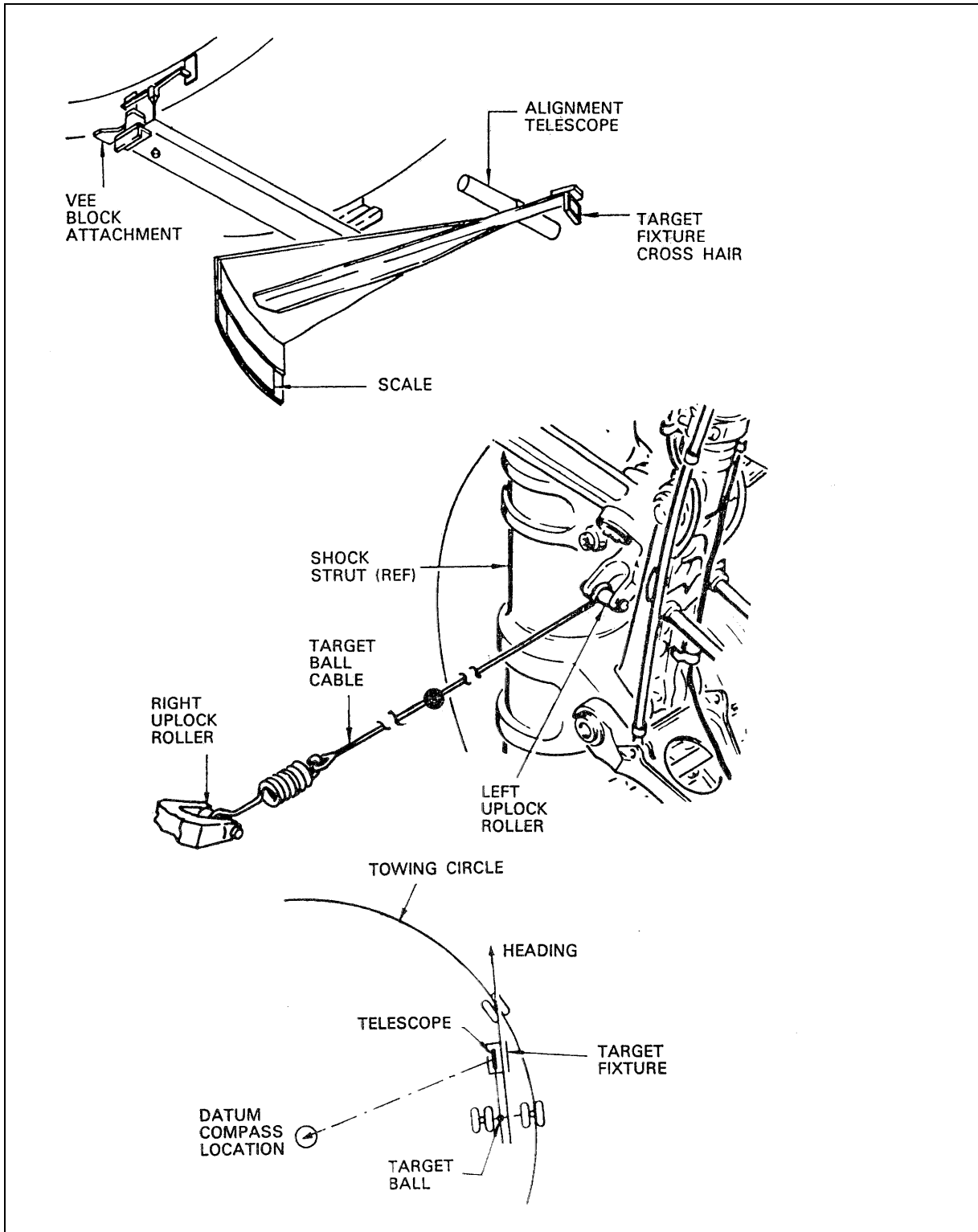

Figure 2 Target Fixture and Ball

10.3 **Plumb Line Sighting**

In this method, the longitudinal axis of an aircraft is indicated by the alignment of two plumb bobs suspended individually from fore and aft points at the underside of the fuselage. The use of the plumb bobs as a means of sighting depends on the compass swinging procedure adopted. If a swing is carried out on a base on which cardinal and quadrantal heading lines are marked out, the aircraft heading is determined by the position of the plumb bobs with respect to the marked lines.

- a) In case of an 'electrical' swinging procedure, the plumb bobs are used only for ensuring that the aircraft is aligned with the North-South line marked out on the base. Malalignment should not exceed a specified amount, usually 1° , and this is calculated from a nomograph comprising three scales corresponding to the separation between plumb bobs, to plumb bob displacement from the North-South line, and to aircraft malalignment. An example based on an aircraft in which the plumb bob suspension points are 76 ft 2 in apart is shown in Figure 3.
- i) When the aircraft is positioned over the North-South line, with its nose pointing North, the points where the plumb bobs come to rest are marked on the ground and the lateral displacement of each from the edge of the line is measured. If the displacement is West of the line it is negative, and if it is East it is positive. The algebraic difference between the two values is then obtained as a reference point on the plumb bob displacement scale, and aircraft malalignment is read off the appropriate scale at the point intersected by a line projected through the known points on the plumb bob separation and projection scales. Thus, in the example shown, the known points are 76 ft 2 in and 4 in, and a projected line intersects the malalignment scale at a value of 18 minutes. In the event that malalignment is greater than the maximum specified for the aircraft, the aircraft should be repositioned.

11 **Compass Swinging Area**

Since the swinging procedure determines deviations caused by the magnetic fields of an aircraft, it is necessary for it to be undertaken at a location where only these fields and the earth's magnetic field can affect the compass readings. The location must, therefore, be carefully chosen and surveyed to prove that it is free from any interfering local magnetic fields (see Leaflet 34-10 Compass Base Surveying).

12 **Compass Swinging Procedure (Direct Reading)**

Where compasses are to be compensated on a base with marked headings, the longitudinal axis of the aircraft must be aligned either on, or parallel to, the markings, usually with the aid of plumb lines dropped from points fore and aft along the axis. A datum compass such as the medium landing compass may also be used, whether or not a concrete or tarmac base is available. The datum compass should be aligned with the aircraft's longitudinal axis and positioned on the datum circle, or if this is not marked, at a specified distance from the aircraft (typical distances are 50 to 150 feet). In order that the longitudinal axis of the aircraft may be accurately determined, datum points on the aircraft and directions from which they are to be sighted, must be carefully selected. Some aircraft have provision for the fitment of sighting rods to aid determination of the longitudinal axis. Details of the procedure appropriate to a specific system and aircraft type are given in the Maintenance Manuals, and reference must, therefore, always be made to such documents. The information given in the following paragraphs is intended to serve only as a general guide to

procedures and to certain associated important aspects. The most straightforward direction for sighting is from the rear; the heading then corresponds to the datum compass reading. If the view from this aspect is unsatisfactory the view from ahead of the aircraft should be considered, bearing in mind that reciprocal headings will be indicated. It is not advisable to take sights from positions at angles to the longitudinal axis.

NOTE: When using a datum compass to position an aircraft, it is not necessary for the aircraft to be set exactly on the cardinal and quadrantal points; settings within 5° are acceptable.

13 Compass Swinging Procedure (Remote Reading)

The procedure to be adopted depends primarily on the type of compass and the method by which magnetic heading reference datum is obtained, i.e. from a base having headings marked out on it, from a datum compass, or from a base established for carrying out 'electrical' swinging as outlined in paragraph 13.2. Details of the procedure appropriate to a specific system and aircraft type are given in the Maintenance Manuals, and reference must therefore always be made to such documents. The information given in the following paragraphs is intended to serve only as a general guide to procedures and to certain associated important aspects.

13.1 Conventional Swinging Procedure

The term 'conventional' is used here to signify a procedure in which the magnetic heading reference datum is obtained, either from a compass base with heading alignment marks painted on it, or from a datum compass. In the former case, and with the aid of plumb line sighting, an aircraft can be aligned precisely on the cardinal and quadrantal headings. When using a datum compass, such precise alignment is not essential since the compass is always positioned to sight on the aircraft. It is usual, therefore, for positioning of both aircraft and datum compass to be within certain permissible limits. Limits commonly specified are within the range $\pm 3^\circ$ to $\pm 5^\circ$. A typical swinging sequence is outlined in the following paragraphs.

- 13.1.1 When the aircraft has been towed onto the base, the appropriate sighting equipment should be fitted (see paragraph 4.2) and the aircraft positioned so that it is heading North.
- 13.1.2 Compasses installed in aircraft with fuselage-mounted engines should be compensated with engines running. If this is not practical then they should at least be re-checked on four equally spaced headings with the engines running, on completion of the swinging procedure.
- 13.1.3 External power supply should be connected to the aircraft, and after the compass systems have been energised and their gyros allowed to run up to normal operating speed, carry out the preliminary checks specified in the appropriate Maintenance Manuals. The following checks are typical of those normally required for systems in current use:
 - a) Synchronising of heading indicators against annunciator devices to ensure that magnetic monitoring by flux detector units, has ceased before taking readings. In certain types of compass system this check is effected by plugging a centre-zero milliammeter into 'monitoring current' sockets provided in a unit (e.g. an amplifier) of the system. If the gyro has no drift, monitoring has ceased when the meter oscillations are evenly balanced about the indicator 'null' position within the tolerances specified for the particular system. In some cases, a monitoring meter

forms part of a compass indicator, thereby obviating the need for a centre-zero milliammeter.

- b) Slaving of compass system indicators, e.g. radio magnetic indicators.
- c) Check heading signals to auto-pilot and other associated navigational systems after selection of appropriate system switch positions.
- d) Operational check of power failure warning and other indicating flags on all heading indicators.
- e) Drift rate check of gyros.
- f) Setting of deviation compensators to their neutral positions. This is normally only done during an initial swing procedure, and whenever a new flux detector unit or a deviation compensator is installed (see also paragraph 15). If a compensator is of the permanent magnet type, the slots of the adjustment screws should be aligned with datum marks on the compensator body. In the case of a potentiometric type compensator the potentiometers should be adjusted until a 'null' position, as indicated by a test meter plugged into the compensator, is obtained. If a new flux detector unit has been installed its index error scale should also be aligned at the zero datum.

NOTE: It is recommended that if no new components have been installed, compensators should remain at their previous settings so that with each subsequent adjustment procedure, some indication of how coefficients change with time can be obtained.

13.2 **'Electrical' Swinging Procedure**

An 'electrical' swinging procedure is one in which the earth's magnetic field is simulated by electrical signals in such a way that it is unnecessary to rotate the aircraft onto the various headings as in the conventional forms of swinging. The aircraft is positioned heading North with its fore-and-aft axis co-incident with a North-South line marked on the selected compass base, and with its flux detector units positioned over marked location datum points (see also paragraph 10.2.3 and Leaflet 34-10). The electrical signals are in the form of varying d.c. voltages, the values of which are determined during the appropriate compass base survey procedure (see Leaflet 34-10) and also during the swinging procedure. The signals are designated as E1 and E2 voltages and are applied respectively to the A-leg pick-off coil and the B-leg and C-leg pick-off coils of the flux detector sensing elements, by adjusting the controls of a console unit forming part of a special calibrator set which can be connected into the flux detector circuit. The electromagnetic fields produced by the E1 and E2 voltages alter the effective magnitude and direction of the earth's field passing through the legs of the detector sensing element, resulting in a magnetic vector which rotates to various headings, thereby simulating rotation of the aircraft and detector unit relative to the earth's field. These simulated headings are compared with the actual headings indicated by the aircraft compass system to determine the deviation errors to be compensated.

13.2.1 **Compass Calibrator Set**

It is beyond the scope of this Leaflet to go into the complete details of the compass calibrator set and its use in the 'electrical' swinging procedure, reference should, therefore, always be made to the relevant manufacturer's operation manual. The information given in the following paragraphs serves only as a general outline.

- a) A compass calibrator set consists of a turntable, magnetic field monitor, field tester, console, power supply and optical alignment unit. The magnetic field monitor (which is a theodolite with a 22x telescope and a magnetic sensing element) is used, in conjunction with a console unit, to measure the strength, and

determine the direction, of the horizontal component of the earth's field. It is used for the magnetic survey of areas required for swinging (see Leaflet 34-10) and also to monitor changes in magnetic conditions during a compass swing. The magnetic sensing element is similar to that employed in a remote indicating compass flux detector unit, except that it is nonpendulous.

- b) The turntable is also a theodolite but without a telescope and magnetic sensing element. It is used for calibrating and aligning certain types of flux detector unit (see paragraph 13.2.2 b)) with magnetic North, and for determining the index or Coefficient 'A' error before installing a unit in the aircraft.
- c) The console unit is the central control unit of the calibrator and contains all the switches, controls and indicators for programming the E1 and E2 voltage signals and for determining the errors in aircraft compass system indications to be compensated. The console also provides interconnection of the magnetic field monitor, turntable and power supply unit. The power supply unit is a solid-state inverter which converts a 28V d.c. input into a 115V 400 Hz a.c. output required to operate the calibrator.
- d) An optical alignment unit consists of a fixed-focus 8x telescope and appropriate adjustment devices, and is used for aligning certain types of flux detector unit in an aircraft during its transfer from the turntable, thereby ensuring that the index error compensation is maintained (see paragraph 13.2.2 e)).

13.2.2 Swinging Procedure

The procedure for carrying out an 'electrical' swing depends primarily on whether a flux detector unit is of the pre-indexed type, or of the master type (pre-calibrated and pre-indexed). Basically, however, the procedure consists of the following sequence of operations:

- a) **Check on the Direction of Magnetic North.** This is done to determine whether there has been any shift from that obtained when the base survey was carried out. The check is carried out by sighting the calibrator monitor, from its location point on the base, on the pre-determined reference target, and then determining errors on the cardinal headings, and thus obtain an area compensation value for setting on the console control unit.
- b) **Magnetic Alignment of Detector Unit.** The purpose of this operation is to check the Index or Coefficient 'A' Error, and thereby the amount by which the detector unit is to be offset in its mounting with respect to magnetic North. If the detector units are of the pre-indexed type, the check is done with the unit mounted on the calibrator turntable at its location on the base, and before the aircraft is towed onto the compass base. In the case of master type detector units, the aircraft can be towed onto the base at the outset of the swing procedure, since the units, being pre-calibrated on the four cardinal headings for a specific compass system and aircraft installation, are already installed and the use of the turntable is thereby eliminated.
- c) **E₁ and E₂ Voltages Check.** The purpose of this check is to determine the voltages required to simulate the earth's field effects which would be obtained if the aircraft and its detector units were rotated onto various headings. The check also determines the adjustments which are necessary to compensate for one-cycle errors, i.e. Coefficients 'B' and 'C', during the compass swing operation.

The check applies to both pre-indexed and master type flux detector units, except that in the former case, voltage values are obtained by selecting headings on the

calibrator turntable, while for master units selections are made on the calibrator monitor.

- d) **Determination of Crosstalk Errors.** These errors (see paragraph 5.4) are measured at headings of 90°, 180° and 270°. Crosstalk error does not occur at 0 degrees since no voltages are applied to the flux detector unit to simulate this heading.
- e) **Optical Transfer of Flux Detector Unit.** This operation is applicable only to flux detector units which have not been pre-indexed or pre-calibrated. It is carried out by means of the calibrator optical alignment unit, and is necessary in order to ensure that a detector unit will be installed in the same position with respect to magnetic North, as that determined by the calibrator turntable magnetic alignment check. The aircraft is towed onto the base and positioned so that not only is the longitudinal axis coincident with the North-South line with the nose pointing North, but also the flux detector unit access location is directly over that of the calibrator turntable. The optical alignment unit is then attached to the detector unit and a reference bearing is obtained by sighting the telescope on a target which is at least half-mile distant from the base.

The values of aircraft malalignment and the flux detector unit index error, are then set into the optical alignment unit, and the detector unit, with equipment attached, is transferred to its mounting bracket in the aircraft and is rotated until the telescope is again aligned with the distant reference target. At this setting the detector unit is secured to its mounting bracket and electrically connected to its compass systems. The optical alignment unit is then removed.

NOTE: Optical transfer is a critical operation in 'electrical' swinging procedure, and extreme care should be taken to prevent the telescope from being jarred or knocked out of adjustment before a flux detector unit is fully secured in its mounting bracket.

- f) **Compass Swinging.** This operation, which applies to all compass systems irrespective of the type of flux detector unit employed, is the one in which compensations are made for one-cycle (Coefficients 'B' and 'C') and two-cycle (transmission) errors. Before compensating, a final check on E1 and E2 voltage values should be made, and adjustments should, where necessary, be carried out to allow for any possible changes in the earth's field strength. On completion of all adjustments, a final swing through increments of 15° should be carried out.

NOTE: Variations between compass system compensation can occur depending principally on the type of compensator used. Reference should, therefore, always be made to the relevant system and aircraft Maintenance Manuals.

13.3 Swinging by Inertial Navigation Systems

With the introduction of Inertial Navigation Systems (INS) into certain types of public transport aircraft, the use of system display unit heading information, as the datum for compass swinging, became a possibility. The swinging procedure, although basically similar to that employing an external magnetic datum, does however, require that the effects of diurnal changes in local magnetic variation be taken into account in order to minimise compass deviation errors.

- 13.3.1 Variation is the horizontal angle between the true and magnetic meridians, and in the United Kingdom it normally increases Westerly during the morning and decreases during the late afternoon. These diurnal changes, as they are called, are in the order of 0.1 degrees in the winter, and 0.3 degrees in the summer. During periods of high sunspot activity however, the changes become random and may increase in amplitude to 0.5 degrees, and have been known to be as large as one degree. In the case of a compass swing using an external magnetic reference datum, the diurnal

changes do not affect the swing since both the datum compass and the aircraft compass are affected by the same changes and the correct deviations are calculated. Furthermore, as long as the compass base has a constant value of variation over it, an accurate compass swing can be carried out irrespective of the value of local variation. In using INS heading information as a datum, diurnal changes will, however, affect only the aircraft compass, thereby giving rise to false deviation errors which require the application of variation corrections. An outline of a method of applying the corrections, based on that prescribed for a particular type of aircraft using three inertial navigation systems, is given in the following paragraphs:

- a) The aircraft is positioned within 2° of North using the readings of the INS display units, and the average of the three readings is noted. The aircraft's magnetic heading is then determined by applying the value for the local magnetic variation to the average of the display unit readings. For Westerly variation the value is added and for Easterly variation it is subtracted.
- b) The heading indications of the compass systems are then noted, after allowing each system to synchronise, and the deviations of each system on the North heading are calculated.
- c) The foregoing procedure is repeated on the other three cardinal headings, and the deviation coefficients are calculated and compensated in the manner prescribed for the particular compass systems.

13.3.2 Although the method described in paragraph 13.3.1 takes into account local variation on all cardinal headings, it should be noted that it is still possible for false deviations to occur as a result of diurnal changes taking place, for example, during the time required for compass systems to synchronise. Unless continuous calculations are made, or the aircraft headings are checked with the aid of an external datum compass, it is unlikely for local variation to be known accurately for the duration of the swing. Serious consideration should, therefore, be given to the maximum compass error which might occur during an INS datum swing compared with one using an external magnetic datum, and whether such error can be accepted for the aircraft compass systems concerned.

14 Compensating and Recording

When taking compass readings a brief pause should be allowed after placing the aircraft on each heading and the direct reading compass should then be tapped gently while the magnet system is allowed to settle. If compensating a remote compass, allow time for the compass to synchronise. A check should always be made on each heading to ensure that interference from each individual item of electrical equipment and its associated wiring, or the interference from the most adverse combination of the possible electrical load, has not been increased. For card type compasses, the readings are taken against the vertical lubber line. If the compass is of the grid steering type, the grid wires should be aligned parallel to the magnet system, North on North, and the reading against the lubber line should be observed. In both cases observations should be such that parallax errors are avoided.

NOTE: When more than one direct-reading compass is fitted in an aircraft, or when a direct-reading compass serves as a standby to a remote-reading compass, all readings and subsequent adjustments should be made simultaneously on each heading.

14.1 All observed readings and associated deviation calculations obtained during swinging should be recorded on properly prepared record forms. The layout of forms varies for different compensation methods but, in general, their composition follows that associated with the method described in this Leaflet and as set out in Table 1.

Table 1

Points	(1) Datum Compass or Base* Reading	(2) Aircraft Compass Cardinal Readings	(3) Deviation	(4) Deviations Corrected for C or B, as applicable	(5) Aircraft Compass Quadrantal Readings	(6) Deviation	(7) All Deviations Corrected for A	(8) Finally corrected Readings for Card
N	000	006	-6	-4	-	-	-2	002
E	090	088	+2	+1	-	-	+3	087
S	180	182	-2	-4	-	-	-2	182
W	270	270	0	+1	-	-	+3	267
NW	315	-	-	-	317	-2	0	315
NE	045	-	-	-	048	-3	-1	046
SE	135	-	-	-	138	-3	-1	136
SW	225	-	-	-	227	-2	0	225

*A compass base was used in this example.

$$C = \frac{\text{Deviation on N} - \text{Deviation on S}}{2} = \frac{(-6) - (-2)}{2} = \frac{-6 + 2}{2} = \frac{-4}{2} = -2^\circ$$

$$B = \frac{\text{Deviation on E} - \text{Deviation on W}}{2} = \frac{(+2) - (-0)}{2} = \frac{+2}{2} = +1^\circ$$

A = The sum of the Deviations on

$$\frac{N \ E \ S \ W \ NW \ NE \ SE \ SW}{8} = \frac{-4 + 1 - 4 + 1 - 2 - 3 - 3 - 2}{8} = \frac{-18 + 2}{8} = \frac{-16}{8} = -2^\circ$$

- 14.2 The aircraft should first be headed N and the compass reading should be noted in column 2 of the Table, e.g. 006°. The deviation is the difference between the compass reading (column 2) and the magnetic heading indicated by the datum compass or compass base (column 1); the sign is plus or minus according to whether it is necessary to add the deviation to, or subtract it from, the compass reading in order to obtain the magnetic heading. In this example it is -6° and this should be recorded in column 3.
- 14.3 The compass reading on E should next be checked, and the deviation obtained and recorded, e.g. 088° and +2°.
- 14.4 The aircraft should now be headed S and the compass reading and deviation also recorded, e.g. 182° and -2°. Coefficient 'C' should be calculated algebraically from the formula shown in the Table; thus, from the example readings, 'C' is -2°. This should be applied, with its sign unchanged, to the deviation noted on S and the result recorded in column 4, i.e. -4°. The sign of the coefficient should then be changed and applied to the deviation on N, the result being -4°, which should also be recorded in column 4. The appropriate adjusting spindle of the compensator device should be rotated until the compass indicates the corrected reading, i.e. 184°. The compass should be tapped gently whilst making the adjustment.
- 14.5 The compass reading on W should be checked next, and the deviation recorded, e.g. 270° and 0°. Coefficient 'B' should be calculated algebraically from the formula shown in the Table; thus, from the example readings, 'B' is +1°. This should be applied, with its sign unchanged, to the deviation noted on W and the result recorded in column 4, i.e. +1°. The sign of the coefficient should then be changed and applied to the deviation on E, the result being +1°, which should also be recorded in column 4. The appropriate adjusting spindle of the deviation compensator device should be rotated until the compass indicates the corrected reading, in this case 269°. The compass

should be tapped gently whilst making this adjustment. This completes the compensation of deviation on the cardinal headings.

- 14.6 The aircraft should again be headed on each cardinal heading and any residual deviations noted. A check should then be made on the compass reading, and deviation, at each quadrantal heading and these should be recorded in column 5 and column 6 respectively.
- 14.7 Coefficient 'A' should be calculated from the formula shown in the Table (after correction for coefficients 'C' and 'B'). It will be noted from the example readings that coefficient 'A' is -2° . Corrections should be made by adding this coefficient (sign unchanged) to the compass reading on any aircraft heading, and by adjusting the mounting position of the compass (e.g. rotating it about bolts in slotted mounting lugs) through the appropriate number of degrees until the lubber line is aligned with the corrected heading.
- 14.8 After correction for coefficient 'A', residual deviations should be calculated in order to obtain corrected readings for entry on the deviation card (column 8). The deviations, which should not exceed 3° (5° for light aircraft) on any heading, are calculated by subtracting coefficient 'A' from the deviations noted in columns 4 and 6, recording the values as in column 7, and then finally subtracting these values from the datum compass or base readings (column 1).
- 14.9 **Deviation Card**

A deviation or 'steer by' card (see Figure 4) should be compiled to show deviations related to standard headings at intervals of 45° (30° for light aircraft) and should be secured in a position adjacent to the respective compass. The card readings are those which the compass must indicate in order that the aircraft may be flown on correct magnetic headings, e.g. in order to fly on a magnetic heading 000 (North) the compass must indicate 002° . In cases where radio equipment is installed in instrument panels, it should also be stated whether the compass was swung with the equipment switched on or off. Details should be given on the back of the card to indicate aircraft type and registration, compass type and serial number, place and date of swing, signature and authority of the compiler. A record of the swing should be entered and certified in the aircraft Technical Log Book

For Magnetic Heading		Steer by Compass
N	000°	002°
NE	045°	046°
E	090°	087°
SE	135°	136°
S	180°	182°
SW	225°	225°
W	270°	267°
NW	315°	315°

Figure 3 Typical Deviation Card

15 Compass Swinging In Service

15.1 Direct Reading Compass

Swinging and compensation as detailed in paragraph 14 must be carried out whenever a direct-reading compass or separate deviation compensator device, if appropriate, is installed. On other occasions a check-swing is sufficient. A check-swing consists of placing the aircraft on four headings 90° apart, and comparing the deviations with those on the existing deviation card. If there is any difference between these deviations it will be necessary to carry out a complete swing.

15.2 Remote Reading Compass

The swinging procedures described in paragraph 14 should normally be carried out after installation of a complete compass system, and whenever standard type, or pre-indexed type, flux detector units are changed. Changing of a master type detector unit does not usually downgrade the performance of its associated system unless alignment of the unit in its mounting bracket, or alignment of the bracket itself, has been altered. Normally, a complete swinging procedure should also be carried out after a deviation compensator device has been changed, although in some systems this may not be necessary provided that compensating voltage settings are properly transferred to the replacement unit. On all other occasions it is sufficient only to carry out a check swing by placing the aircraft on four headings 90° apart, and comparing any deviations with those recorded on the previous calibration swing. If there is any difference between these deviations, a complete swinging procedure should be carried out.

15.3 Occasions for Check Swing of Compass:

- a) After a check inspection if required by the approved Maintenance Schedule.
- b) Whenever inaccuracies in heading indications are reported.
- c) After any modification, repair or major replacement involving magnetic material, particularly in aircraft the engines of which are mounted in the fuselage or wing nacelles.
- d) Whenever a compass has been subjected to shock, e.g. after a heavy landing.
- e) After the aircraft has passed through a severe electrical storm, or has been struck by lightning.
- f) Whenever the aircraft has been subjected to a magnetic crack detection examination.
- g) Whenever the sphere of operation of the aircraft is changed to one of different magnetic latitude.
- h) Whenever a significant change is made to the electrical or radio installation, particularly to circuits in the vicinity of the compass.
- i) Whenever a freight load is likely to cause magnetic influence and thereby affect compass readings.
- j) After the aircraft has been in long term storage.

16 Routine Inspection

The security of the mounting of each compass and deviation compensator device should be checked, and any adjustment or tightening should only be done by an

organisation approved by the CAA for such work or by an engineer licensed in the appropriate category. The compass should be inspected for bubbles in the liquid, discoloration, sediment, clarity of scale, liquid leakage, cracked glass and the effectiveness of the anti-vibration mounting where fitted. In compasses of the grid steering type, the functioning of the grid-ring locking device should also be checked, and when in the unlocked position it should permit complete rotational freedom of the grid-ring. The deviation card must be legible and secure in its holder.

INTENTIONALLY LEFT BLANK

Leaflet 34-30 Radio Altimeters and AVADs for Helicopters

PURPOSE: This Leaflet provides information and guidance concerning the installation of Radio Altimeters and audio voice alerting device/systems (AVAD).

REFERENCES: ANO 2016 Schedule 6 Scale EE
CAP 612 (Police Air Operations Manual)
CAP 999 (UK Helicopter Search and Rescue (SAR))

1 Introduction

- 1.1 To meet the requirements of Schedule 6 Scale EE of the ANO 2016 and the operating requirements under a Police or Search and Rescue Air Operator's Certificate (AOC), certain helicopters will need to be equipped with a Radio Altimeter and display indicator providing a voice and visual warning of descent below a pre-set height above surface level. This Leaflet provides guidance material on complying with these requirements.
- 1.2 Whilst most current Radio Altimeters include a height warning light, this is not considered sufficient for alerting a pilot to an inadvertent descent as his attention may be directed away from the indicator at the critical time. It is for this reason that an audio low height warning is considered necessary. An aural tone on its own is not considered to be acceptable. The warning must be distinguishable from other warnings and should therefore be a clear and concise voice message.

2 Requirement and Background

- 2.1 Schedule 6 of the ANO has, since 1 February 1986, required an audio warning operating below a pre-set height and a visual warning capable of operating at a height selectable by the pilot when a Radio Altimeter is fitted.
- 2.2 As an alternative, for helicopter flights under a Police AOC, both the audio and visual warnings may instead be capable of operating at a height selectable by the pilot.
- 2.3 Additionally, the Radio Altimeter and AVAD may be required operationally for night and Night Visual Imaging System (NVIS) flights.

3 Warning Format

- 3.1 In order to gain acceptance, the audio warning requires certain characteristics. They are:
- a) The warning should be unique (voice).
 - b) It should not be inhibited by any other audio warnings.
 - c) The urgency of the warning should be adequate to gain attention but not such as to cause undue annoyance during deliberate descents through the datum height.
- 3.2 Research activity has indicated that the characteristics above can be satisfactorily met if the warning format incorporates the following features:
- a) A unique tone should precede the voice message. A further tone after the voice may enhance uniqueness and attention-getting without causing undue annoyance.
 - b) The perceived urgency of the tone and voice should be moderately urgent.
 - c) The message should be compact as opposed to lengthy, provided the meaning is not compromised, e.g. 'One fifty feet' as opposed to 'One hundred and fifty feet'.
 - d) An information message is preferable (e.g. 'One hundred feet'). Messages such as 'Low height' do not convey the correct impression during deliberate descents through the datum height.
 - e) Command messages (e.g. 'Pull up, Pull up' are not acceptable unless they relate specifically to height monitoring (e.g. 'Check height').
 - f) The volume of the warning should be adequate and not variable below an acceptable minimum value.
- 3.3 Every effort should be made to prevent spurious warnings.

4 Altitude Trigger

- 4.1 The height at which the audio warning is triggered by the radio altimeter should be such as to provide adequate warning for the pilot to take corrective action. It is envisaged that most installations will adopt a height in the range of 100 – 160 ft. It will not be permissible for the datum to be altered in flight, except as provided for in 2.2.
- 4.2 The pre-set height should not be set such that it will coincide with commonly used instrument approach minima (i.e. 200 ft). Once triggered, the message must sound within 0.5 seconds.
- 4.3 The voice warning should be triggered only whilst descending through the pre-set height and be inhibited whilst ascending.

5 Approval Considerations

- 5.1 All Radio Altimeters must be CAA or EASA approved in accordance with BCAR Section A Chapter A4-10, and conform to either EUROCAE ED-30, EASA ETSO-2C87, FAA TSO C87 or RTCA DO 155.
- 5.2 All automatic voice alerting devices (AVAD) must be CAA or EASA approved in accordance with either the Accessory Procedure or Component Procedure of BCAR Section A, Chapter A4-8, Section B, Chapter B4-8 (non-EASA aircraft) or EASA Part 21 (EASA aircraft) as applicable.

6 Installation Aspects

- 6.1 The airframe installation must be approved under the modification procedures of BCAR Section A, Chapter A2-5, BCAR Section B, Chapter B2-5 (non-EASA aircraft) or EASA Part 21 (EASA aircraft) as applicable.
- 6.2 For a two pilot side by side seating cockpit, a single Radio Altimeter indicator may be permissible provided it is so arranged as to permit either flight crew member to see the indications readily from their seats with the minimum practical deviation from the position and line of vision they normally assume when looking forward along the flight path.
- 6.3 Radio Altimeters should be of an analogue type display that require minimal interpretation by the pilot for both an instantaneous impression of absolute height and rate of change of height. Digital only displays are not acceptable.
- 6.4 A suitable 'DH' amber light is acceptable as satisfying the ANO requirement for a 'Visual Warning'.
- 6.5 Radio Altimeters when fitted to helicopters operating under a Police Air Operator's Certificate must be capable of being powered in all phases of flight, including emergency situations, without intervention by the crew. Other helicopters are recommended to be powered accordingly.

Leaflet 34-40 Certification and Installation of ACAS 1 Equipment and Other Similar Non-Mandatory Aircraft Collision Avoidance Systems¹

PURPOSE: This Leaflet provides guidance for the certification and installation of ACAS 1 type equipment. A Flight Manual/Pilot's Operating Handbook (POH) supplement template is provided in Appendix 1 which, when completed, should be submitted to the Flight Manuals and MMEL Unit, Aviation House, Gatwick for approval. Guidance on ground and flight testing is given together with modification classification guidelines.

The leaflet is only applicable to non-EASA aircraft.

REFERENCES:

CS-23 Normal, Utility, Aerobatic and Commuter Category Aeroplanes

CS-27 Small Rotorcraft

CS 29 Large Rotocraft

ETSO-C118 TCAS 1

ETSO-C147 TAS

FAA TSO C147

Air Navigation Order 2009 (CAP 393)

BCAR Section A (CAP 553), sections A8-1, A8-2, A8-8, A8-9 and A8-21

AIC 37/2006 (Yellow 199)

BCAR Section K

BCAR Section G

CAA CAP 761 - Operation of IFF/SSR Interrogators in the UK - Planning Principles and Procedures

CAP 747 - Mandatory Requirements for Airworthiness, Generic Requirements (GRs) Nos. 4 and 6

CAP 562 - CAAIP Leaflet 51-80

1 Introduction

This Leaflet is issued in response to the increasing demand for non-mandatory Traffic Collision Avoidance System installations (TCAS 1 and TAS types).

These types of systems provide 'Traffic Alerts' (TA), including approximate bearing and range information. Unlike ACAS II (TCAS II Version 7), TCAS 1 does not provide

1. Excludes passive Collision Avoidance Systems that do not transmit signals in order to interrogate nearby SSR transponders, and ACAS II systems (carriage of ACAS II is mandatory for certain aircraft). The term Traffic Advisory System (TAS) may also be used to describe TCAS 1 'type' systems.

Resolution Advisories (in the form of vertical guidance to the pilot). The BF Goodrich, Skywatch System is similar in operation to TCAS 1 and for the purposes of this Leaflet it may be considered a TCAS 1 type system.

The guidance provided in this Leaflet is intended to assist the design organisation, maintenance organisation and aircraft operators to determine the certification considerations required to demonstrate compliance with the applicable airworthiness requirements. This Leaflet also provides some guidance on the installation considerations.

2 Airworthiness Approval

When assessing the installation of TCAS 1 installations the following needs to be considered:

2.1 Equipment Approval Issues

TCAS 1 type systems are not required to be installed on an aircraft to meet any airspace or operational requirement. These systems do, however, transmit and receive radio signals.

Article 39(8) of the ANO 2009 (as amended) requires that all radio communication and radio navigation equipment installed in an aircraft registered in the UK, or carried on such an aircraft for use in connection with the aircraft, shall be of a type approved by EASA or the CAA in relation to the purpose for which it is to be used.

2.2 Power Supply Considerations

The equipment should not be connected to the aircraft's emergency or battery supported busbar.

2.3 Performance Considerations

Good bonding and positioning of the TCAS 1 antenna(s) is essential to ensure correct operation of the system, and non interference to other aircraft systems.

The performance demonstration needs to include appropriate ground testing and possible flight evaluation. The ground test should demonstrate correct bearing and range of targets in each quadrant. An EMC (Electromagnetic Compatibility) test should be performed to ensure that the installed system does not affect existing aircraft systems. A flight evaluation is at the discretion of the installer, and may be conducted using targets of opportunity to confirm the correct operation of the system.

2.4 Flight Manual/Pilot's Operating Handbook (POH)

The modification will require a Flight Manual/Pilots Operating Handbook (POH) Supplement which will need to address, at least, the following:

Limitations:

Navigation must not be predicated on the use of the TCAS 1 display.

Normal Procedures:

If a 'Traffic Alert' (TA) is received, the pilot should not initiate a manoeuvre based on the display alone, without first visually acquiring the target .

Emergency Procedures:

None

Abnormal Procedures:

None

Performance:

None

A Flight Manual/Pilot's Operating Handbook (POH) Supplement template for a 'typical' TCAS 1 type installation is contained in Appendix 1 to this Leaflet.

The Design Organisation should submit the Flight Manual/Pilot's Operating Handbook (POH) Supplement, as detailed in Appendix 1, duly completed, to the Flight Manuals and MMEL Unit, Aviation House, Gatwick for approval.

Guidance on the compilation of a Flight Manual/Pilot's Operating Handbook (POH) supplement is provided in Appendix 2 to this Leaflet.

2.5 Electrical Load Analysis

The installation of TCAS 1 will affect the Electrical Load Analysis, and may affect compliance with CAP 747 GR Nos. 4 and 6. Continued compliance with these GRs will therefore need to be demonstrated.

2.6 Structural Analysis

A structural analysis of the installation, including the TCAS antenna(s) and their mountings must be conducted.

3 Classification of Modification

Classification of design changes is generally performed in accordance with BCAR A8-21, however a TCAS 1 type installation may be classified as **MINOR** provided the following conditions are satisfied:

- a) The TCAS 1/TAS equipment is of a type approved by CAA/ETSO authorisation and previous installations have been approved.
- b) The Flight Manual/Pilot's Operating Handbook (POH) Supplement requires no additional limitations, other than those listed in the Flight Manual/Pilot's Operating Handbook (POH) Supplement template given in Appendix 1.
- c) There is no effect to the existing instruments on the Flight Deck, by installation of the Traffic Display. For example, if the Traffic Display displaces another instrument, causing an overall change to the flight deck, an assessment of the flight deck will be required by Flight Department. Also, if the Traffic Display is located outboard of the main instrument panel by means of a bracket, or if it is located on the glare shield, a Flight Department assessment may be required.
- d) Interfacing of TCAS 1 with existing onboard sensors does not introduce possible failures to existing aircraft systems. An assessment may be required if existing systems are affected. Example: failure (signal grounded) of an altitude input to TCAS 1. If this input also supplies altitude information to other aircraft systems, a failure introduced by TCAS 1 could affect existing aircraft systems. (Pilot's display of barometric height could be affected, transponder output of Mode C altitude data could be affected.)
- e) TCAS 1 aural alerts do not inhibit any other aural alerts.

4 Approval to Operate an IFF/SSR Interrogator

All TCAS 1 or TAS systems that transmit interrogation signals on 1030 MHz require a separate approval to operate from the National IFF/SSR Committee (NISC). Certain specified ACAS 1 equipment has a generic approval from NISC. However, all other ACAS 1 systems require approval on a case-by-case basis. Further details can be found in AIC 37/2006 (Yellow 199), TCAS I Systems Approvals Policy, in CAP 761, Operation of IFF/ISSR Interrogators in the UK: Planning Principles and Procedures and on the Airspace Policy pages on the CAA website at: www.caa.co.uk. Enquiries and applications for approval should be submitted to:

NISC Secretariat
K6 G6
CAA House
45-59 Kingsway
London WC2B 6TE

Tel. 020 7453 6536
E-mail: nisc@caa.co.uk

For Airworthiness certification aspects, further information may be obtained from:

Airworthiness Evaluation and Surveillance Department
Aviation House
Gatwick Airport South
West Sussex
RH6 0YR

Tel. 01293 57 3132

For Flight Manual/Pilot's Operating Handbook (POH) and MMEL aspects, further information may be obtained from:

Flight Manuals and MMEL Unit
Airworthiness Evaluation and Surveillance Department
Aviation House
Gatwick Airport South
West Sussex
RH6 0YR.

Tel. 01293 57 3187 or 01293 57 3189.

Appendix 1

TEMPLATE FOR TCAS 1

FLIGHT MANUAL SUPPLEMENT/PILOT'S OPERATING HANDBOOK (POH)

<<Aircraft Type>> Flight Manual (or POH as appropriate) Reference <<XXXX>>

<<Company Name>>

FLIGHT MANUAL/PILOT'S OPERATING HANDBOOK (POH) SUPPLEMENT <<x>> ISSUE <<y>>

Registration Mark:.....

Serial Number

TCAS 1

Modification Number <<XXXX>>

ADDITIONAL LIMITATIONS AND INFORMATION FOR CERTIFICATION

The limitations and information contained herein either supplement or, in the case of conflict, override those in the Flight Manual/Pilot's Operating Handbook (POH).

LIMITATIONS

Navigation must not be predicated on the use of the <<insert name of TCAS 1 type system>> display.

If a 'Traffic Alert' <<insert aural message here, for example 'Traffic, Traffic'>> is received, the pilot should not initiate a manoeuvre based on the display alone, without first visually acquiring the target.

NORMAL PROCEDURES

The normal procedures specified in the Basic Flight Manual remain applicable.

EMERGENCY PROCEDURES

None

ABNORMAL PROCEDURES

None

PERFORMANCE

None

To be inserted in the Flight Manual/Pilot's Operating Handbook (POH) and the record sheet amended accordingly.

Page 1 of

CAA Approval

Date:

INTENTIONALLY LEFT BLANK

Appendix 2

NOTES ON THE PRODUCTION OF FLIGHT MANUAL / PILOT'S OPERATING HANDBOOK (POH) SUPPLEMENT

- a) The supplement should be written to fit the size and style of the Flight Manual/Pilot's Operating Handbook (POH) supplied by the aircraft manufacturer and to which it refers, preferably without resorting to photo-reduction.
- b) A company logo can be included if desired.
- c) The supplement must be uniquely identifiable within the referenced Flight Manual/Pilot's Operating Handbook (POH).
- d) A log of supplements should already be provided in the front of the manual/handbook. This log should be amended to reflect the additional supplement. Where no log of supplements exists, the design organisation/installer will provide one.
- e) Aircraft identification (Registration etc.) will be added to the copy which goes in the aircraft copy of the Flight Manual/Pilot's Operating Handbook (POH). Where several aircraft on the same Flight Manual/Pilot's Operating Handbook (POH) document have the same equipment, copies of the same Flight Manual/Pilot's Operating Handbook Supplement may be issued to each aircraft and annotated with the aircraft's identification accordingly.
- f) If a supplement is submitted for approval for a specific aircraft registration and/or serial number, the supplement will only be approved for that particular aircraft.
- g) Any information contained in the system users manual that addresses: the system's Limitations, Normal Procedures, Emergency Procedures, Abnormal Procedures and/or Performance, should be detailed in the Flight Manual/Pilot's Operating Handbook (POH). Provision of this information in the Flight Manual/Pilot's Operating Handbook (POH) by referencing the system's users manual should also be carried out with the guidance contained in AC 25.1581-1 & AMJ 25.1581.
- h) When approved, one copy of the supplement should be placed, as appropriate in the aircraft's Flight Manual/Pilot's Operating Handbook.

INTENTIONALLY LEFT BLANK

Chapter 39 Electrical-Electronic Components and Multifunction Units

Leaflet 39-10 The Selection and Procurement of Electronic Components

1 Introduction

The selection and procurement of electronic components for use within aircraft equipment or for direct fitment to airframes continues to present problems for those concerned with airworthiness procedures for Civil Aircraft. This Leaflet prescribes how the relevant British Civil Airworthiness Requirements (BCAR) should be applied in order to achieve design and quality control of equipment and components.

2 Definition

- 2.1 The term Electronic Components, as interpreted by the BSI and other agencies, may include such items as micro-switches or electrical connectors which are likely to be fitted directly to an airframe. More conventionally the term Component also refers to parts such as capacitors and resistors which have no method of mounting other than by the soldered electrical connections. The application of such terms is usually within an equipment which itself is approved for installation in an aircraft.
- 2.2 For the purpose of this Leaflet such items are referred to as:
- Aircraft Components**, for items *fitted directly* to airframe or engine, and
 - Component Parts**, for items *fitted within* equipment. BCAR Chapter A4-8 gives further definition of the terms used in this Leaflet.

3 Design Responsibility

- 3.1 **Aircraft Components** The requirements for electrical aircraft components are given in BCAR Chapter A4-8 and Certification Specifications 25.1351 to 25.1363, the installation requirements of electrical items is further considered in BCAR Section D6-1.
- 3.2 For the correct interpretation of this Leaflet it is important to understand the significance of the terms '**Controlled**' and '**Uncontrolled**' as applied to electrical components. For items used as Aircraft Components as defined here, the known or probable use will determine the approval category and, for Controlled Items, the requirements of paragraph 5 of BCAR Chapter A4-8 will need to be followed as appropriate. The term 'Uncontrolled' relates solely to the status of items in their functional role in an aircraft and does not imply that such components may be ignored. Paragraph 2 of BCAR Chapter D6-1 requires those designing installations to consider the suitability of 'Unclassified parts and Equipment' and, where necessary, these 'shall be controlled to a standard to ensure compliance with the relevant requirements of Section D'. Thus the design and build standard of the 'Uncontrolled Item' may still be subject to a measure of control under the CAA procedures prescribed in this Leaflet to ensure that no new unassessed failure modes are introduced.

- 3.3 The selection and use of Aircraft Components is normally the responsibility of an Approved Organisation with appropriate Terms of Approval under BCAR Section A procedure. Such organisations need to satisfy themselves, and ultimately the CAA, as to the suitability of an equipment in a given application. This is most conveniently done by obtaining a Declaration of Design and Performance (DDP) to a format based upon that given in BCAR Chapter A4-8 paragraph 7, BS 3G100 Part 1 or ISOR224. The authorisation of the DDP by an Approved Signatory within an Approved Organisation and its acceptance by the user constitutes Approval under Component Procedures. If the design authority for an equipment additionally obtains approval for their product from the CAA then the equipment is said to be 'Accessory Approved'. It is important to note, however, that 'Accessory Approval' does not absolve the user from ensuring that the item to be used as an Aircraft Component is suitable for the particular application.
- 3.4 The assurance that the products obtained are as declared on the DDP is a function of a clearly defined purchase order requiring 'CAA Release'. (See paragraph 5) In the context of this Leaflet it is essential that users appreciate that generalised claims that an item is approved can only relate to the conformity with specifications, compliance with which may, or may not, have been validated by a third party. Approval for aircraft use is a function of selection by an authorised Design Authority who will, in effect, approve the application of the item.

4 Component Parts – Selection

- 4.1 The designer of a piece of equipment which utilises individual component parts has freedom of choice in the matter of selection provided that the equipment taken as a whole meets its design specification and the relevant Airworthiness Requirements. The Requirements of BCAR Chapter A4-2 have to be satisfied and this establishes the need for control of the identification, reliability and modification standard of component parts. Users and overhaulers of equipment need to be able to procure component parts which will maintain the established and accepted reliability of the total equipment. It follows that all necessary information regarding special testing, selection or condition of component parts shall be given in Overhaul Manuals.
- 4.2 Items produced to BS 9000 Specifications may well be suitable if the defined level of quality is compatible with the declared reliability for the total equipment, as further noted in paragraph 7.

5 User Responsibility

- 5.1 Users and overhaulers of equipment are responsible for showing compliance with the requirements of BCAR Chapter A4-2 when obtaining replacement 'component parts' as stated in paragraph 4 of this Leaflet. It is emphasized that overhaulers of equipment are required to obtain authorisation before making substitutions or in any way deviating from the spares or replacements listed in the relevant Approved Overhaul or Maintenance Manuals of a 'controlled' item of equipment. In all cases of difficulty in procurement of the items referred to in Approved Manuals, the acceptance of alternatives must include authorisation by an appropriate Design Organisation.
- 5.2 BCAR Chapter A4-8 paragraph 6.1 provides guidance on the control of quality of components obtained from overseas suppliers.

6 The Approved Certificate

- 6.1 Users are reminded that the function of an Approved Certificate issued by a CAA Approved Organisation (who will hold an Approval Number DAI/ xxxx/ xx or AI/ xxxx/ xx) is intended to ensure that the purchaser obtains the items which are ordered. The use of an Approved Certificate does not automatically confer any 'CAA Approval' status on the product and it is the responsibility of the purchaser to reference the required part or drawing number on his order, together with any other necessary definition. The issue of a proprietary item on an Approved Certificate indicates that the producing organisation is approved and that appropriate CAA procedures have been followed, and will be followed in the event of any subsequent enquiry. It is apparent, therefore, that it is not necessary for products to be Design Approved by the CAA before they are released unless this is a condition of the order.
- 6.2 Purchasers should note that airworthiness procedures are applicable to airborne equipment and requests for 'CAA release' should be restricted to items which fall within the requirements of BCARs and where, therefore, the release has significance.

7 BS 9000 Electronic Components of Assessed Quality

Users proposing to accept components supplied to any form of BS 9000 specification or other specification systems employing similar formats should note and understand the assured quality aspect which is employed. Statistical sampling techniques essentially involve an element of risk which is determined by the Acceptance Quality Level (AQL) and sampling plans referenced in the specifications. The CAA will expect users of BS 9000 components to hold copies of specifications concerned and to be in a position to appreciate the significance of the quality assurance techniques employed in these and other specifications involving sampling techniques.

INTENTIONALLY LEFT BLANK

Leaflet 39-20 Antistatic Protection

1 Introduction

- 1.1 Certain semi-conductor devices are susceptible to damage from electrostatic charges and are at risk in any environment where they may come into contact with such charges. The prime risk during maintenance activities is the static charge held on personnel and tools, whilst in storage the risk is from the charge held on personnel and non-conductive packaging materials.
- 1.2 The metal oxide semi-conductor (MOS) and complementary MOS (CMOS) family of devices is most prone to damage from static electricity. Bi-polar devices which are also susceptible to this type of damage include, but are not limited to, Operational Amplifiers, Emitter-coupled Logic (ECL) devices and Transistor-transistor Logic (TTL) devices. In addition, there is evidence to show that thick and thin film resistors, multi-metal-layer hybrid substrates, discrete transistors and diodes, Field Effect Transistors (FET) and Schottky TTL devices also suffer damage from electrostatic discharges.
- 1.3 The information given in this Leaflet, although based on practices which, when carried out by properly trained personnel, are proving to be effective, is intended to serve only as a general guide to the establishment of certain minimum standards of conduct during handling, packaging, storing and testing of these devices.

2 MOS Device Manufacture

- 2.1 In an electronic circuit, a MOS device functions as a voltage-controlled resistor in which the MOS equivalent resistance between the drain and source is varied by a voltage applied to the gate electrode (see Figure 1). Physically, the gate electrode is a thin layer of metal deposited on a very thin layer of silicon dioxide (SiO_2 (glass)), typically 1000 to 1400 Angstroms thick. This layer of glass effectively insulates the gate electrode from the substrate, in essence, forming a capacitor, the plates of which are the gate electrode and substrate with the dielectric being the layer of glass between the gate electrode and substrate.

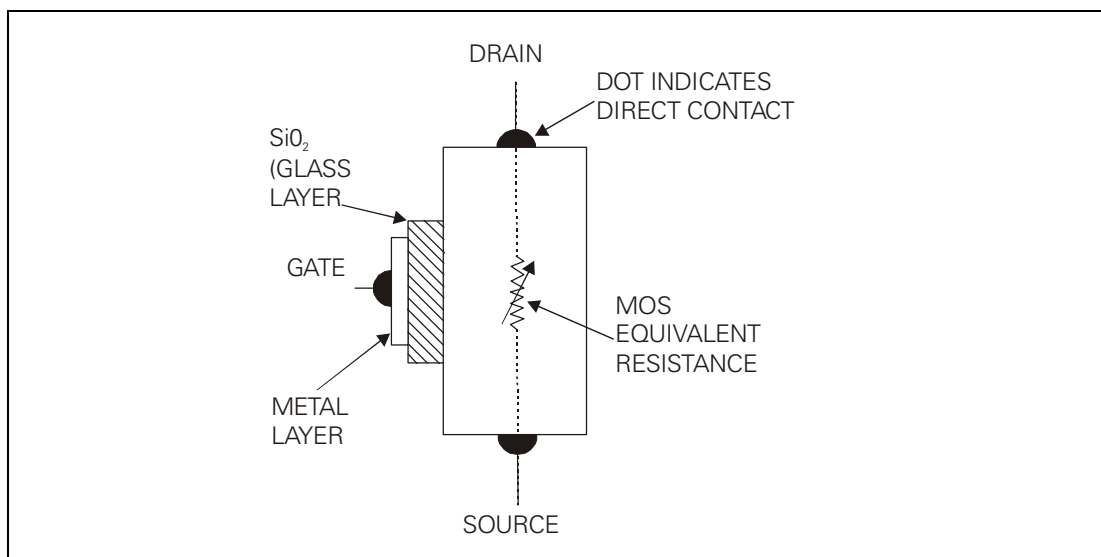

Figure 1 Typical MOS Device Showing the Insulated Gate

- 2.2 The dielectric strength of glass is approximately 101 V/cm, which means that a voltage in the range of 100 to 140V can cause a rupturing of the glass, which would result in catastrophic damage to the device, usually as the result of a short circuit of the gate (electrode) to the source, drain or substrate. To avoid damage from overvoltage, manufacturers of MOS/CMOS devices usually incorporate protective circuitry on the gate electrode input pins (usually some type of resistor-diode network) so designed as to provide an alternative path for transient voltage such as electrostatic discharges. It is not the voltage discharge to ground but the potential difference between the pins on the device which causes the damage. With the elimination of such potential difference the damaging effects of an electrostatic discharge can be prevented.
- 2.2.1 For an unprotected MOS device the resistance at the input pins is approximately 10^{14} ohms. Using this figure it can be calculated that a current of approximately 10^{-12} ampere (10 pA) can generate a 100 V potential which can rupture the layer of glass and destroy the device. Since all protective devices require the addition of some P-region the resistance can normally be reduced to approximately 10^{10} ohms. Although the effectiveness of the protective circuitry varies, most provide protection from human body electrostatic discharges only up to several hundred volts. Thus, such circuits can provide only limited protection against electrostatic discharges, which, in uncontrolled areas, can be measured in thousands of volts.
- 2.2.2 Figure 2 gives a schematic representation of a typical protected MOS device, as indicated by the presence of a built-in zener diode. The source, gate and drain electrodes are the equivalent of the emitter, base and collector electrodes of the typical bi-polar transistor (the substrate lead of the device is normally connected to the source lead). In most cases, the zener diode which protects the MOS device conducts at approximately 50 V. However, selection of a value for the substrate resistance can present a problem to the manufacturer as this resistance value must be great enough to limit current flow to prevent destruction of the zener diode, but must not be so high that the sum of the voltage drop across the zener-resistance combination exceeds the breakthrough voltage of the glass layer.

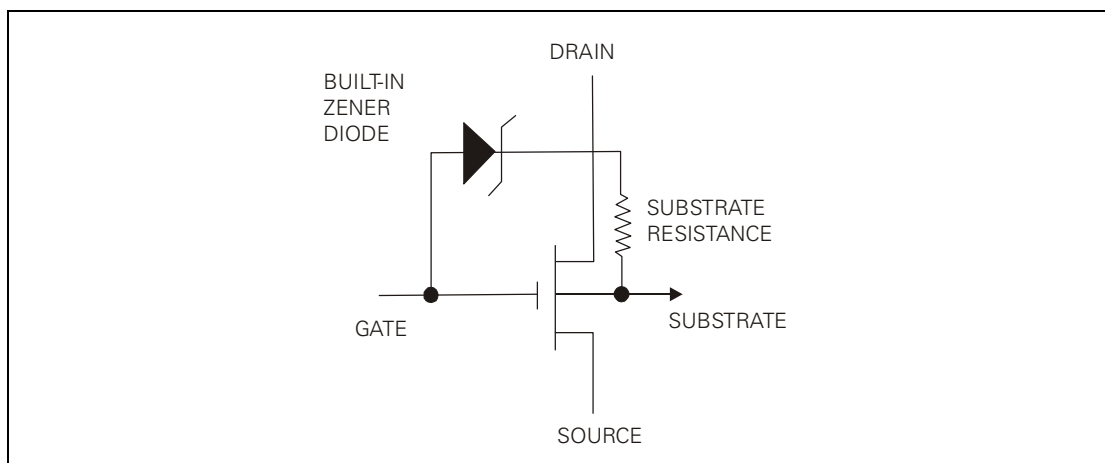

Figure 2 A Typical Protected MOS Device

3 Cause of Static Electricity

- 3.1 **Positive and Negative Charges.** Whether or not an item becomes subject to 'positive' or 'negative' electrostatic charges stems from the atomic or molecular structure of the materials involved in its manufacture. Materials which will readily give

up electrons become charged positively, whereas others which have an affinity for electrons become charged negatively. Whenever two items are brought into contact and then separated, there is likely to be electron transfer and thus electrostatic charging, which can result both from rubbing or non-frictional contact/separation. The net charges on the two materials will be equal but the conductivity (or resistivity) of the materials will greatly affect the potential electrostatic charges involved.

- 3.1.1 The charges tend to dissipate quickly over the entire surface of conductive materials, which not only lowers the electrostatic potential but increases the possibility of further dissipation to other materials which are in contact directly or via an air space.
- 3.1.2 On non-conductive materials the electrostatic charge can remain in localised areas at high potentials, creating electrical fields between themselves and other materials at different potentials and ground. Materials entering these fields can be charged by induction, which takes place when electrons of the material entering the field are attracted to those areas closest to any one of positive potential, leaving behind positive charged areas and creating negative charged areas. This transfer of electrons and consequent electrostatic charging by contact/separation is known as the 'triboelectric' effect.

3.2 Prime Electrostatic Generators

Materials common to electronic maintenance, repair and testing, which can be factors in the generation of electrostatic charges, include the human body, all work surfaces, floors (especially if waxed), furniture, personal clothing (including clean room garments), tools and all non-conductive packaging materials. Some type of motion is required for the generation of electrostatic charges and some non-conductive materials are extremely good generators of such charges. Nylon shirts or smocks, for example, can easily become charged to 20 000 V or higher. However, the human body is, in all likelihood, the most frequent source of damage to sensitive electronic components as a result of electrostatic discharge.

- 3.2.1 The electrostatic potential of the human body is a function of many variables, such as body capacitance, clothing material and style, body activity, relative humidity of the air, footwear, etc. A widely accepted electrical model for the human body is a capacitor (C_{HB}) and a series resistor (R_{HB}). There must, obviously, be a wide range of published values for both parameters, as many variables can affect them, e.g. body size, muscle tone, skin ruptures (spots, cuts, etc.), skin moistness, contact area, footwear, position in relation to the work piece, etc. However, the consensus of opinion would appear to support 200 pF as a reasonable approximation for C_{HB} and 1000 ohms for R_{HB} (including contact resistance). Table 1 gives representative data under typical industrial conditions.

Table 1 Typical Measured Static Charges for the Human Body

Situation	Relative Humidity of Air	
	Low 10-20%	High 65-90%
	Volts	Volts
Walking across a carpet	35 000	1 500
Walking over vinyl floor covering	12 000	250
Worker at bench	6 000	100
Vinyl envelopes containing work instructions	7 000	600
Polythene bag picked up from bench	20 000	1 200
Work chair padded with urethane foam	18 000	1 500

- 3.2.2 Clothing, floor coverings and furniture are not the only generators of static electricity. So, too, are many of the usual materials which are, unfortunately, still used for the packaging and transportation of electrostatic-sensitive semi-conductors and, in many instances, complete printed circuit board assemblies. Tools which have normally been used in electronic engineering and which have been thought to be safe, are often not. One particularly dangerous tool to use on an electrostatic-sensitive device is the plastics de-soldering tool; the sudden rapid movement of the plastics piston in the piston sleeve of the tool can generate a very high electrostatic potential. Another potentially dangerous tool is the electrical soldering iron which, unless it is 'grounded' at the tip, can also be a dangerous electrostatic carrier.

4 General Handling Procedures for All Semi-conductors

- 4.1 It is not possible to lay down a degree of electrostatic protection which would cover all types of semi-conductor. However, there is a strong consensus of opinion that a significant reduction of dangers related to electrostatic charges can be achieved by making personnel aware of possible electrostatic generators and improved general handling techniques, such as:

- a) Not removing or replacing line replaceable units with electrical power applied.
- b) Not unnecessarily touching the connectors, leads or edge connectors, etc., of printed circuit boards containing such devices.
- c) By using conductive packaging, shorting plugs, bands or wire when provided or prescribed in the relevant aircraft or equipment Maintenance Manual.
- d) By paying particular attention to stores procedures to ensure that protective packaging is not removed during any goods-inwards inspection.

5 Electrostatic-free Work Station

5.1 General

If, by the nature and volume of work, it is considered necessary to set up an electrostatic-free work station, guidance may be obtained from the following paragraphs which set out the various options which are open.

5.2 Humidity

A factor which needs to be considered when working with electrostatic-sensitive devices is the humidity of the working environment. The air in a very low-humidity environment is dry and has a very high resistance, such air will not discharge the static electricity as quickly as a moist air. Therefore, the working environment for an electrostatic-free work station should ideally, have a relative humidity of between 30 and 50%.

5.3 Working Environment

There are two basic methods of achieving a safe working environment in which to handle electrostatic-sensitive devices. One is dependent upon the provision of a conductive work surface, which, together with the operator and tools in use, is bonded electrically to a common ground. The other makes use of the conductive properties of an ionised atmosphere to dissipate static electrical charges.

5.3.1 Conductive Work Surface Technique

- a) The work surface of a bench is covered with a sheet of conductive material, e.g. plastics, or mat which is secured to the bench to prevent it from moving. The floor area in front of the bench is also covered with conductive material and electrically bonded to the work surface by means of a bonding strap. To be effective the bonding strap should have a resistance of approximately 2000 to 4000 ohms per linear foot and should be as short as possible. A further bonding strap is used to link a wrist strap, worn by the operator, to the work surface and this should have a resistance of 200k ohms to 1M ohms. To complete the system the work surface is connected to a suitable ground point. In addition the work seat may be covered with a conductive seat cover.

NOTE: Under no circumstances should the work surface of a static-free work station be connected to the electrical power supply ground circuit of the building.

- b) The main disadvantage of the conductive work surface is its conductivity. As each element of the system is bonded to a common ground to which the operator is connected via a wrist strap, immediately the operator is in direct contact with the work surface, which normally has a surface resistivity of approximately 3000 ohms, the wrist strap resistance is rendered ineffective.

5.3.2 Conductive Atmosphere Technique

- a) Electrical Ionisation

- i) An ozone laden atmosphere can be produced by several electrical methods. The safest and most acceptable method relies upon a capacitive connection between its ozone emitting needles and the conductor. The system for producing ozone consists of a rod made up of three separate elements. The outer element is a tube, made of an insulating material, which has stainless steel needles embedded at right angles at intervals along its length; the blunt ends of these needles protrude through to the second element, which is another tube of the same material coated with rings of a silver compound which are in contact with the needles. The third element which forms the centre of the rod is standard HT conductor cable (motor car ignition type) which is connected to an 8000V secondary winding of a mains operated transformer. The complete rod is housed in a metal shroud which both protects and supports it. The effective range of this type of electrostatic eliminator is normally 13 cm (5 in) but can be increased to 61 cm (24 in) by providing an air boost, at a pressure of 14 kN/m² (2 lbf/in²).
- ii) The conductive atmosphere technique depends upon ozone which in concentrations exceeding 1.0 parts per million (ppm) causes discomfort. It has been demonstrated that the ozone concentration 50 mm (2 in) from the nozzle of the eliminator is less than the 0.05 ppm which the Institute of Aviation Medicine states is a maximum for long term exposure. Electrically, the eliminator is completely safe despite the high voltage involved and the emitter rod can be freely handled during operation.

NOTE: Extended periods of working in such an atmosphere may, nevertheless, cause extreme drowsiness.

- b) In special circumstances when the setting up of an electrostatic-free work station is impractical, an air ioniser could be used. A blower projects a stream of air containing both positive and negative ions onto the work surface and onto the operator's hands temporarily neutralising the static charges in the region. These

blowers may also be used in conjunction with a conductive work surface when high levels of electrostatic charging are being experienced.

5.4 **General Operating Procedures**

5.4.1 **Conductive-Surface Work Station**

- a) Following the initial setting up the station should be checked for an effective ground and periodically monitored thereafter. In order to establish that wrist straps have not developed any faults, periodic checks should be made on their resistive value.
- b) Under no circumstances should the operator, or anybody else, touch electrostatic-sensitive devices, or assemblies containing such devices, without first having placed a wrist strap indirect contact with their wrist.
- c) When a conductive surface station is equipped with an air-ioniser blower, the normal operating procedure is to allow the blower to operate for approximately two to three minutes before performing any work. The operator should also move their hands into the ionised airstream for a few seconds, to allow for charge dissipation, before handling electrostatic-sensitive devices.

5.4.2 **Conductive Atmosphere Work Station**

Before commencing work it should be ensured that the ionising bars are working properly. This can be done by checking for the smell of ozone, thus establishing the presence of a cloud of ionised air. Satisfactory operation of the eliminator should also be determined by the vibration felt when it is held loosely in the hand, while the flow of boost air can be felt by passing a hand close to the emitter nozzle.

- 5.4.3 The effectiveness of an electrostatic-free work station can be further checked by the use of an electrostatic-detecting meter. Such meters are normally capable of detecting the presence, indicating the polarity and level of static electricity and can be read on various scales, ranging from 30 to 50 000 V at distances of 6.5 to 30 cm (2.5 to 12 in).

6 **Ground Connections**

- 6.1 For grounding purposes a copper mat or plate should be sunk into the earth to a depth which will ensure that it will be constantly damp. A typical grounding arrangement is shown in Figure 3. Ideally, electrostatic-free work stations should be connected to the grounding mat with a connecting strip of the shortest possible length, so reducing the possibility of radio frequency pick-up.

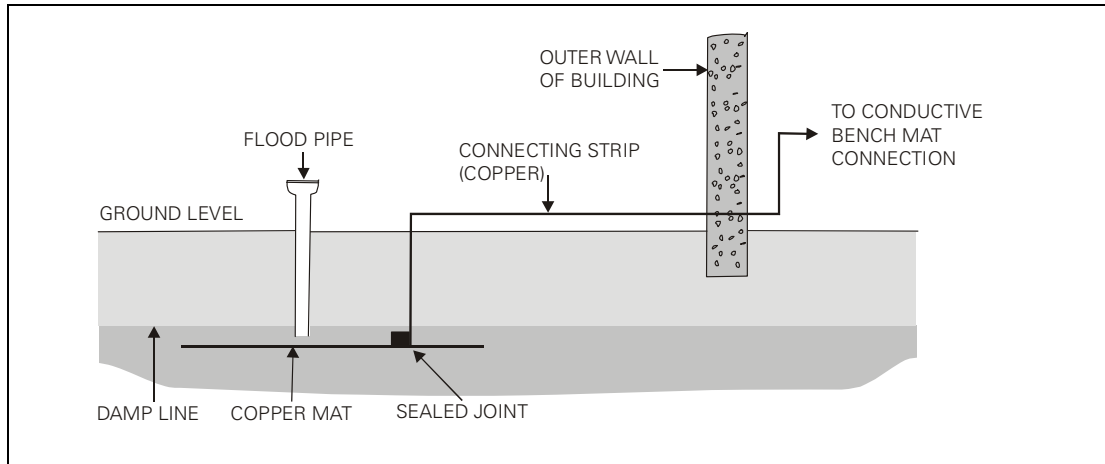

Figure 3 Typical Grounding Arrangement

- 6.1.1 Care should be taken to use a material for the connecting strip which will not create a potential of more than 0.25 V with the material to which it is joined. If the connections are made by welding or soldering, they should be thoroughly cleaned to remove all traces of flux residue and should then be completely covered with a sealing compound or other insulating covering.
- 6.1.2 In well drained locations, it is recommended that a pipe should be sunk over the ground mat to permit occasional flooding of the mat.
- 6.1.3 Where an outside wall position is not possible, a ground mat should be sited under the floor of the building or, alternatively, the work stations may be connected to grounding spikes.

7 Additional Precautions

7.1 General

Providing an electrostatic-free work station will not, on its own, ensure that no electrostatic-sensitive devices will be damaged or destroyed. Complete protection may only be achieved when certain standard operating and handling procedures are also adhered to. Only then will the complete effectiveness of the work station be realised.

- 7.1.1 Persons engaged in maintenance or repair work should be electrostatic conscious and should consider the avoidance of damage by electrostatic charges as a normal responsibility. They should also be aware of the necessity for the elimination of electrostatic generation such as plastics envelopes, non-conductive tapes and other commonly used items made from plastics, nylon and rubber.
- 7.1.2 The effectiveness of an electrostatic-free work station should be regularly checked with a static-detecting meter (see paragraph 5.4.3).
- 7.1.3 Work which involves the handling of exposed electrostatic-sensitive devices should not normally be undertaken outside the confines of an electrostatic-free work station. Such devices and any modules containing them should always be handled by their cases and the unnecessary touching of connecting leads, pins or edge connectors, even if grounded, should be avoided. Modules, printed circuit boards or components should never be removed or replaced with electrical power supplies switched on. Devices which are supplied with pin shorting links or wires should only have such links or wires removed after the devices have been fitted into the circuit.

- 7.1.4 Soldering irons should always be used with a grounded bit, except for those which are normally used in conjunction with an isolation transformer, as grounding of this type of soldering iron may be hazardous to personnel. Any accumulated electrostatic charge on other hand tools should be discharged prior to the tool being used. No attempt should be made to test electrostatic-sensitive devices with a multimeter.
- 7.1.5 For both serviceable and unserviceable electrostatic-sensitive devices, modules and printed circuit boards the same precautions should be observed. It is, therefore, advisable to retain any conductive or anti-electrostatic packaging material removed from serviceable equipment for re-packaging of the unserviceable items, ensuring that the package is suitably labelled to show that the contents are unserviceable but contain electrostatic-sensitive devices.

8 Testing

8.1 General

All testing of equipment containing electrostatic-sensitive devices should be strictly in accordance with the relevant manufacturer's instructions. The following paragraphs only draw attention to the more general precautions which should be observed during testing of electrostatic-sensitive devices and/or printed circuit boards or modules.

- a) In general, such items should not be inserted or removed from their installed positions unless all electrical power is switched off, as transient voltages may cause permanent damage.
- b) When bench testing, input test signals should not normally be injected into such items without electrical power being applied. All unused input connections should also, normally, be connected to a power source or to ground.
- c) Much of the test equipment used for the testing of such items will also contain electrostatic-sensitive devices. While calibration of this type of test equipment will not normally require the operator to wear a wrist strap, if a repair or replacement has to be made involving an exposed device or module, then a wrist strap should be worn and the electrostatic damage-prevention measures of this Leaflet should be implemented.

9 Storage

9.1 General

The creation of a safe storage environment does not depend on the provision of the same kind of facilities which have been outlined. The packaging of equipment precludes the use of a conductive atmosphere technique; therefore, adequate protection is dependent upon the provisioning of a conductive surface. Whilst it is advisable to store electrostatic-sensitive equipment in grounded metal racks and cupboards this alone will not necessarily completely protect such equipment.

- 9.1.1 It is known that plastics and polymer based packaging materials will retain static charges which produce voltage gradients across the surfaces; accordingly, electrostatic-sensitive equipment must never be stored alongside non-electrostatic-sensitive equipment.
- 9.1.2 Electrostatic-sensitive equipment should be packed in a conductive material, such as will ensure that the whole of the package is maintained at the same potential and should then be stored in grounded metal racks or cupboards.

9.2 **General Precautions**

- 9.2.1 All packages containing goods inward should be checked for the presence of electrostatic-sensitive devices by reference to external markings and reference numbers. Any package not so marked should, if it contains electrostatic-sensitive devices, be labelled accordingly and should be handled and stored in accordance with the recommendations of this Leaflet.
- 9.2.2 The conductive packaging of such equipment should never be removed outside the confines of an electrostatic-free work station.

INTENTIONALLY LEFT BLANK

Leaflet 39-30 Protection from the Effects of HIRF (High Intensity Radiated Fields) associated with Aircraft Modifications

1 Purpose

This Leaflet provides information on the issues to be considered when reviewing the HIRF requirement aspects of aircraft modifications.

NOTE: This information does not represent official European Aviation Safety Agency (EASA) policy. However, the information presented is the policy adopted by the CAA and JAA Certification Standardisation Panel. The EASA policy will supersede this Leaflet when available.

2 References

AC/AMJ 20.1317 – Final Draft Issue (EEHWG Document WG327 dated November 98)

EUROCAE ED107/SAE ARP 5583 – HIRF Users Guide – March 2001

EUROCAE ED-14F (RTCA DO-160F) – Environmental Conditions and Test Procedures for Airborne Equipment

EUROCAE ED-90A – Radio Frequency Susceptibility Test Procedures - Users Guide to ED-14F Section 20

NOTE: Although current versions of the above guidance and advisory material are quoted, the latest version of the above documents should always be applied where applicable.

3 Introduction

The current JAA/EASA HIRF Interim Policies are listed below:

INT/POL/25/2 Issue 2

INT/POL/27, 29/1 Issue 3 Draft

INT/POL/23/1 Issue 1

The threat levels and applicability dates for each of the above are varied but generally aircraft have been required to comply with HIRF requirements since early 1992.

Aircraft have therefore been certificated to various HIRF standards, which range from no requirement through to the current policies and standards.

EASA Part 21 A.101 (a) requires that an applicant for a change to a Type Certificate (Changed Product Rule, CPR) must show that the changed product complies with the applicable airworthiness requirements that are in effect at the date of the application, unless the applicant can demonstrate that certain exemptions exist, 21 A.101 (b).

The basic concern for better identification and protection from High Intensity Radiated Fields arose for the following reasons:

- a) Operation of modern aeroplanes is increasingly dependent upon electrical/electronic systems, which can be susceptible to electromagnetic interference.
- b) The increasing use of non-metallic materials like carbon or glass fibre in the construction of the aeroplane reduces their basic shielding capability against the effects of radiation from external emitters.

- c) Emitters are increasing in number and in power. They include ground-based systems (military systems, communication, television, radio, radars and satellite uplink transmitters) as well as emitters on ships or other aircraft.

Changes/modifications to equipment and systems that could be susceptible to the effects of HIRF are not specifically mentioned in 21.101/21.A101; however, such changes could contribute materially to the level of safety. These changes should therefore be considered as 'HIRF significant' in the first instance.

Modifications (STCs and Amended STCs) to aircraft should therefore be assessed for the effects that could be caused by exposure to HIRF, irrespective of the original certification basis.

This document therefore provides advice on the certification activities to be undertaken in this respect for modifications to aircraft for the various original aircraft HIRF certification standards.

NOTE: The approach is scaled dependent on the functional criticality levels (safety levels) determined in the Aircraft/System Hazard Assessment.

4 Advice

CAUTION

In addition to the certification activities that are described below, all modifications should, irrespective of their functional failure classification, be assessed for their effect and impact on existing installed system functions throughout the aircraft. There should be no adverse effect (introduced by wiring installation changes for example) on existing system functions as a result of the modification.

4.1 Aircraft certificated to the latest/current HIRF Policies

Modifications that involve electrical or electronic equipment changes should be assessed for full compliance with the latest HIRF Interim Policy to the level appropriate to the system functional criticality.

4.2 Aircraft certificated to an earlier/intermediate HIRF Policy

Following the original introduction of the JAR HIRF Policies (JAR 25 policy in 1992, JAR 27/29 policy in 1997) there have been iterations of the associated field strengths and test criteria. Aircraft were certificated to different standards deemed to be current at the time of aircraft certification. The actual values used were recorded in Certification Review Items (CRIs), which formed part of the aircraft certification basis. The field strengths used for the various frequency ranges could therefore be higher or lower than current values, dependent on the frequency band.

For aircraft certificated in this period, any future modifications that involve electrical or electronic equipment changes should be assessed for compliance with the HIRF requirements appropriate to the system function criticality level. The field strengths and test criteria to be used can either be based on the original standard at the time of certification or the latest standards, depending on the available equipment or aircraft test data available.

4.3 Aircraft certificated prior to the introduction of the HIRF Policy

As stated above, the HIRF requirements/policies were first introduced in 1992 to address concerns associated with the increasing use of electrical/electronic systems, non-metallic structures and the proliferation of RF transmitters.

When considering modifications to aircraft certificated prior to the introduction of the HIRF requirements the concerns regarding the use of electrical/electronic systems and the proliferation of RF transmitters are still valid if the modification involves changes to electrical or electronic equipment.

Therefore, modifications on this standard of aircraft that involve changes to electrical or electronic equipment should still address the issue of HIRF.

The consideration of HIRF should primarily focus on system functions, the failure of which would prevent the continued safe flight and landing of the aircraft. Consideration should also be given to those system functions the failure of which would cause large reductions in the capability of the aircraft or the ability of the crew to cope with adverse operating conditions. This will require an assessment of the criticality of the functions of the modified/changed equipment.

Compliance with HIRF requirements typically involves aircraft tests, equipment tests, analogy or similarity or any combination. As part of the normal equipment qualification process the equipment may have been tested to levels commensurate with the intended environment, i.e. the equipment would have been assessed as 'fit for its intended environment'. It is therefore possible that compliance with the HIRF requirements could be demonstrated by a review and analysis of the equipment and/or aircraft test data, without further equipment or aircraft testing.

Note that changes to Control Systems, the failure of which would prevent the safe flight and landing, require compliance to be based on actual aircraft testing or by similarity to other comparable aircraft tests.

Introducing electronic equipment based systems that are required by the certification specifications (e.g. CS 25) or operating rules that replace previously installed "Non-electronic" equipment systems which performed the same, or equivalent functions should consider HIRF. In such instances, the new equipment will be of a nature that could be susceptible to HIRF, and demonstrating that it performs its intended function when exposed to the operating environment (compliance with 23/25.1301(d) or 25.1309(a) – depending on certification basis) will necessarily need to include the consideration of HIRF.

The previously installed equipment would not necessarily have been susceptible to HIRF due to the nature of the components used.

If the "new electronic systems" can introduce a functional failure classification of Major, Hazardous or Catastrophic compliance with the HIRF policy should be shown. The application of the HIRF requirements demonstrates compliance with 2X.1301(d) and 2X.1309(a) and will show that the equipment is able to perform its intended function when installed in its operating environment.

5 Additional Points

The certification requirements for the HIRF aspects of any modification should be discussed with the Civil Aviation Authority at an early stage.

The acceptance of a modification from an applicant is predicated on the availability of the necessary original aircraft and equipment design data on which to base the HIRF assessment.

INTENTIONALLY LEFT BLANK

Leaflet 39-40 Lightning Strike Hazards on Light Aeroplanes and Gliders

1 Purpose

The purpose of this Leaflet is to provide technical information that may be useful when considering lightning protection for light aeroplanes. The information contained in this Leaflet is based on CAA (UK) experience with light aeroplanes. The implementation of this Leaflet alone may not be sufficient to meet the applicable lightning requirements. The users of this Leaflet are advised to identify the applicable lightning requirements and the acceptable means of compliance for the aeroplanes in consideration. Enquiries should be directed to the responsible Airworthiness Authority.

2 Introduction

The information given in this Leaflet outlines the problems which may be encountered on aeroplanes fitted with metallic or non-metallic tip tanks or other external non-metallic components and gives information on methods of reducing their vulnerability to lightning strikes.

Further information or assistance can be obtained from:

Engineering Section
Airworthiness Evaluation and Surveillance Department
Safety Regulation Group
Civil Aviation Authority
Aviation House
Floor 2E
Gatwick Airport South
West Sussex
RH6 0YR

Tel: 01293 573134 or 01293 573293

3 Lightning – What Is It?

In order to appreciate the problems of lightning strikes it is felt that a short description of the differences between static electrical charging and lightning associated with aircraft would be useful. These fall into three categories:

- a) Precipitation Static is the build up of charging on the aircraft by its passage through charged particles in the air. It is unlikely to cause damage to the aircraft but does interfere with radio, especially HF and ADF frequencies, and can cause serious navigation and communication problems. It can be attenuated by fitting static dischargers on the aircraft wing tips and empennage.
- b) St. Elmo's Fire is the visible corona of static discharge when passing through densely charged conditions, and is a very clear indication that the local areas are intensely charged and lightning may occur.
- c) Lightning Strikes. Natural lightning flashes usually originate from charge centres in a cloud. The positive and negative charges in clouds are produced by complex processes of freezing and melting and by movements of raindrops and ice crystals

involving collisions and splintering. The strong electric fields can initiate discharges, called lightning flashes, which may be of three types, namely:

- i) Flashes between regions of opposite polarity within a cloud (intra cloud discharges),
- ii) Flashes between regions of opposite polarity in different clouds (inter cloud charges), and
- iii) Flashes from clouds to ground and from ground to clouds of either polarity. Ground to cloud flashes, however, become only relevant to taller objects, e.g. towers and mountains.

A lightning strike to an aircraft will either be triggered (i.e. initiated) by the presence of the aircraft in a strong electric field and will originate at the aircraft, or will occur as a result of encounter with a naturally occurring discharge path. The result of a lightning strike is voltages and currents of an extremely high order passing through the aircraft structure which are capable of damaging component assemblies or destroying wiring and equipment if not adequately protected. System operational upseting may also occur.

4 Lightning Protection

When an aeroplane is struck the discharge will most probably enter and leave by the wing tips, nose or empennage and it is therefore these components that require special protection. All should be adequately bonded to each other through the aircraft's metallic structure or, in the case of non-metallic aircraft, by bonding links throughout the complete structure.

Wing and empennage tips (see Figure 1) can be protected by fitting copper straps either solid or a woven sheath of at least an equivalent to 1" x 26 SWG cross sectional area attached to the component to form a complete cage, and bonded to the structure at the nearest joint. However this is not always practical on existing parts and as an alternative metallic foil tapes can be glued on the exterior, but again should be bonded to the airframe, and routine inspections should be carried out to check against damage by erosion. It should also be noted that should the tape be struck it will burn away probably without damage to the airframe.

Wing tip fuel tanks made from non-metallic materials (see Figures 2, 4 and 5) should be given special attention and only external bonding may be used. This may be similar to that used on wing tips but in addition it is vital to ensure that the navigation lamp plus its earth return cable and associated duct is bonded to the airframe as near the wing tip as possible. Where the tanks are of all metal construction (see Figure 3) it is necessary to ensure that the nose and tail are not less than 0.080" thick in order to reduce the danger of being punctured by the lightning strike. The safest tank design is one with an air space at either end thus eliminating any fuel vapours from the most dangerous areas.

Where loss of or damage to a non-metallic nose cone can hazard the aeroplane it can be protected by a suitable cage (see Figure 6) in the shape of a cruciform fitted either inside or outside and made from similar materials as the wing tip protection. If radar is fitted (see Figure 7) fingers should be brought as far forward as possible without affecting the radar efficiency.

5 Gliders

Attention should be given to these aircraft, especially those of non-metallic structure, and bonding straps should be installed between the extremities to conduct any strike away from the flying controls. A point to remember is that bonding should be run as straight as possible avoiding loops formed by excess lengths at, for example, transport joints, since a lightning strike will jump across any sharp loops or bends.

6 Illustrations

The illustrations shown in this section are for information only and do not represent every aeroplane or their variants or the type of bonding that may be used.

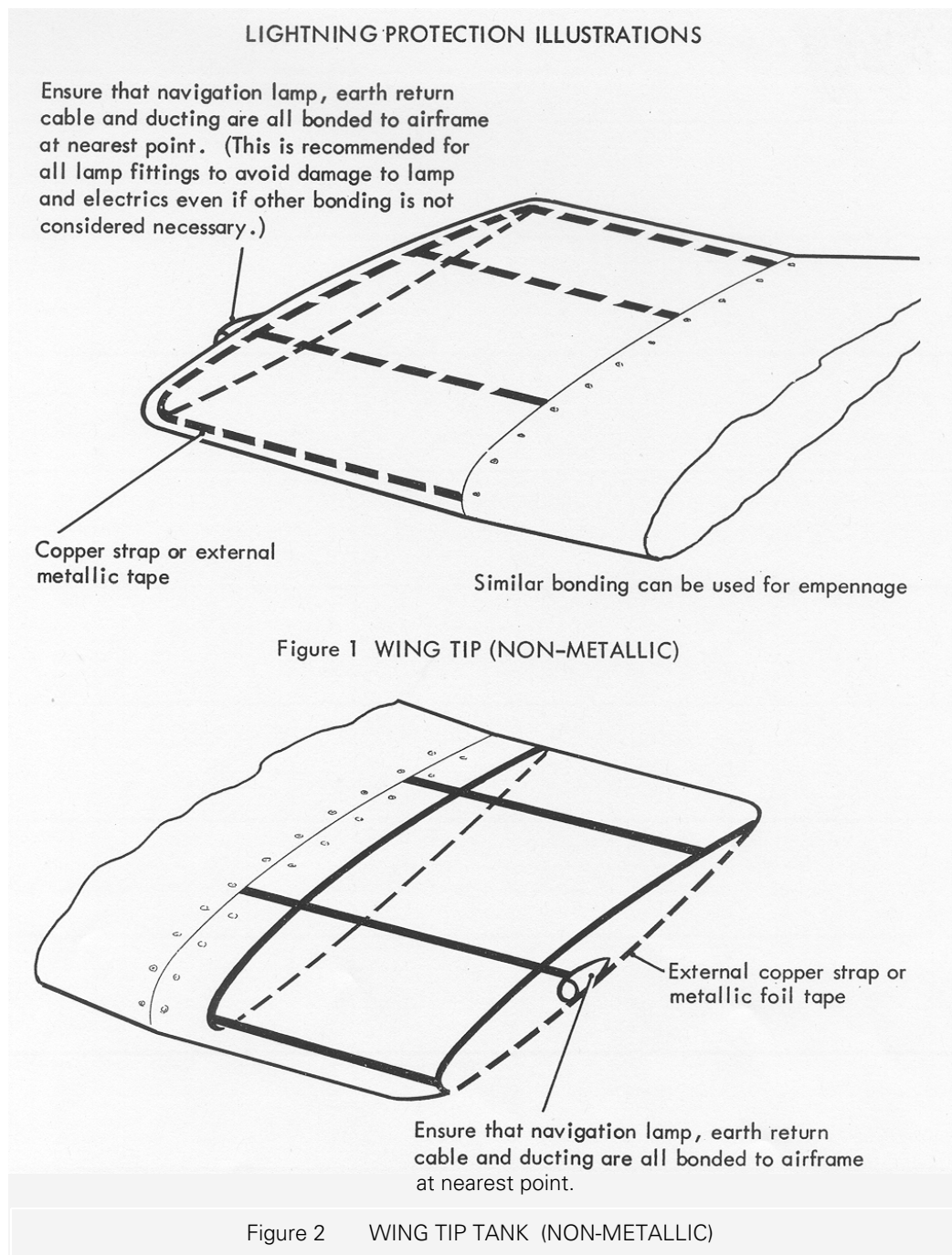

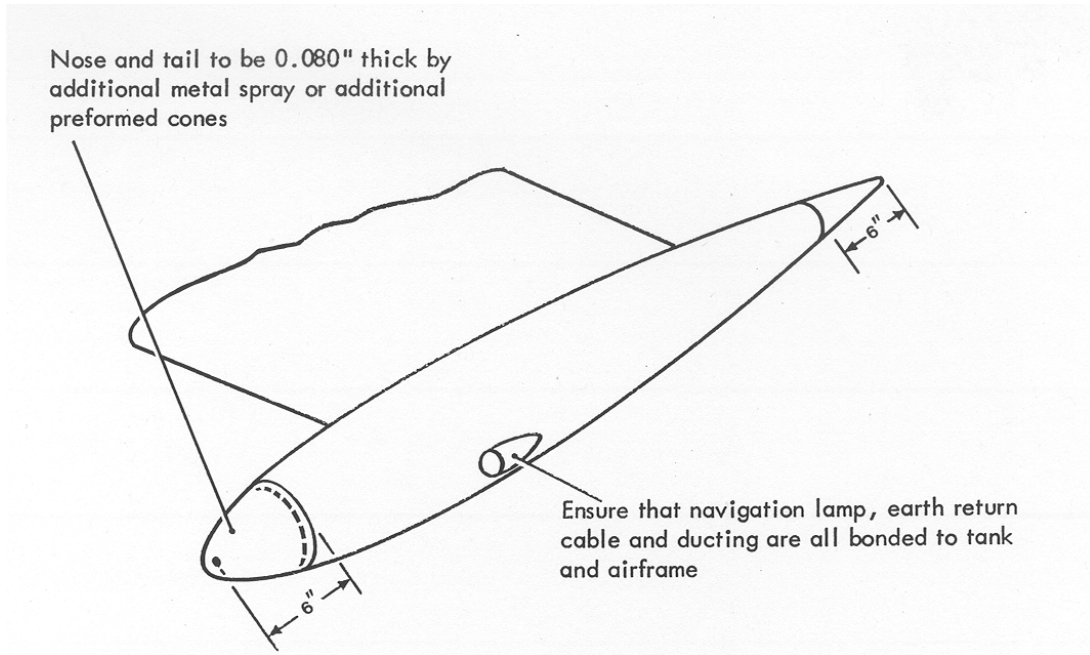

Figure 3 WING TIP TANK (ALL METAL)

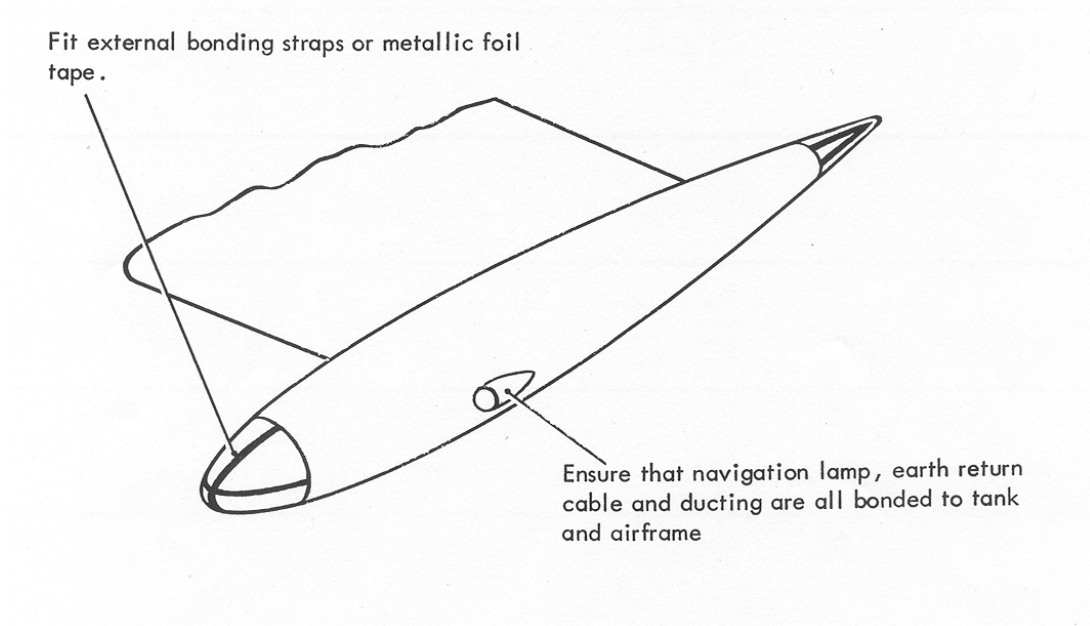

Figure 4 WING TIP TANK (NON-METALLIC ENDS)

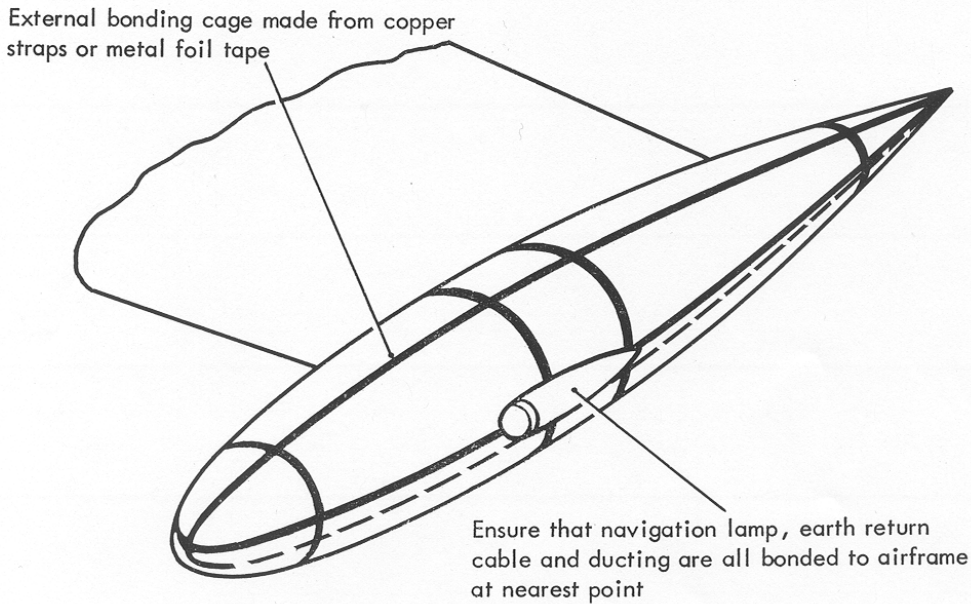

Figure 5 WING TIP TANK (NON-METALLIC)

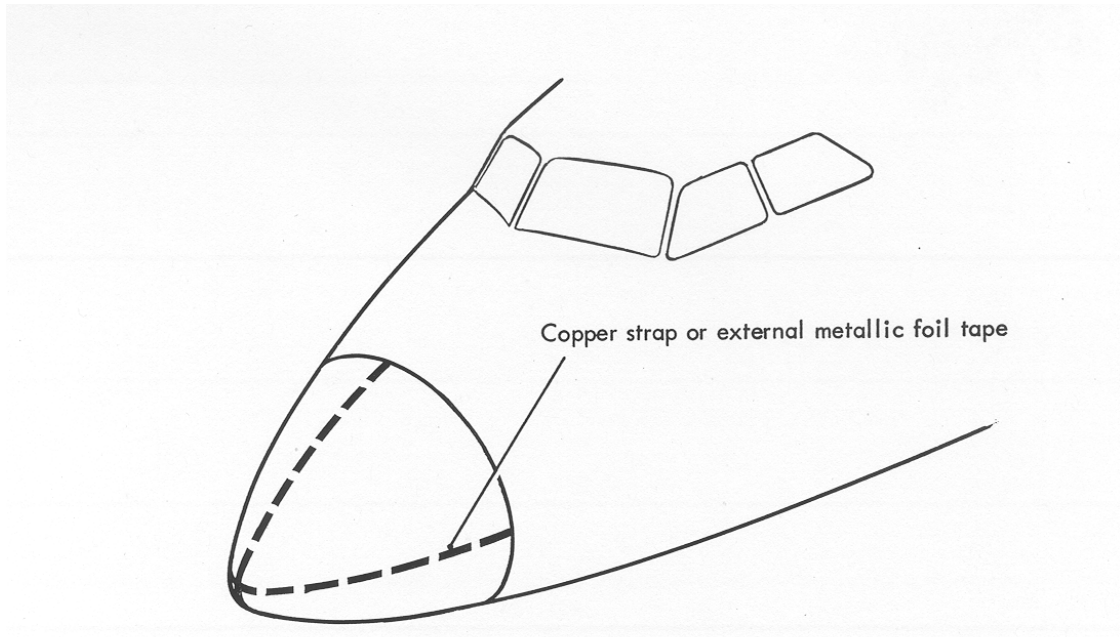

Figure 6 NOSE CONE (NON-METALLIC)

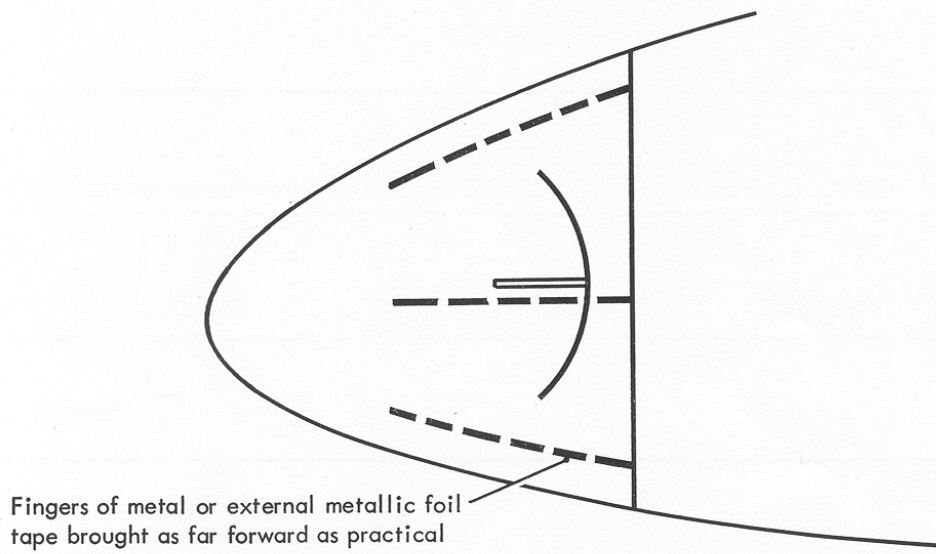

Figure 7 RADOME

Chapter 44 Cabin Systems

Leaflet 44-10 Continuing Airworthiness and Safety Standards of Passenger Service and In-Flight Entertainment Systems

1 Introduction

- 1.1 In recent years the aviation industry has experienced a number of incidents involving In-Flight Entertainment systems (IFE). IFE systems now regularly include integration with a variety of related equipment, including seat movement mechanisms, video systems, lighting and telecommunications. (For the purposes of this Leaflet all further references to IFE will also include consideration of these integrated systems and does not differentiate between 'one-off' modifications on corporate aircraft and series installations on commercial aircraft).
- 1.2 The availability of innovative electronic technology makes it clear that the increasing use of new technology within passenger cabins will continue. Significantly, more complex systems and their electrical wiring installations demand higher power consumption. Most IFE systems are installed as operator optional modifications and may not be subject to original aircraft manufacturer involvement. This has resulted in Instructions for Continuing Airworthiness (ICAWs), scheduled maintenance and system maintenance manuals being overlooked or given minimal consideration.
- 1.3 The CAA has conducted a review of the above concerns, the outcome of which identified a number of issues. This Leaflet has been published to provide guidance as to the best practice approach to gaining approval of and continuing airworthiness of In-Flight Entertainment systems and the related passenger services. In particular it identifies the need to consider and where appropriate determine maintenance practices to assure the continuing airworthiness of the systems in service.

2 Background

- 2.1 The variety and complexity of passenger in-seat services and the cabin installation can involve several disparate and separately approved modifications. The lack of specific scheduled maintenance guidance from the Supplemental Type Certificate (STC) Holder(s), for the total installation, is considered a potential weakness of the certification process. This can lead to a lack of clarity as to where the overall responsibility for the continuing airworthiness of the interface between the aircraft and the modified systems lies.
- 2.2 The adequacy of the certification requirements and objectives is not in question, but their practical interpretation can lead to system interface design and installation problems. In particular, defined standards for equipment and wiring installation/reinstallation are often minimal. IFE systems are often installed by organisations other than the aircraft manufacturer that can lead to differences in installation between otherwise identical aircraft, thus contributing to in-service problems.
- 2.3 Experience from the investigation of occurrences has shown that the condition of the installed system can deteriorate as a result of cabin environmental conditions. The constituent parts of an IFE system installation, including wiring, located within the passenger cabin are likely to be disturbed or removed on numerous occasions

throughout the operational life of an aircraft. This increases their vulnerability to occurrences if the maintenance standards and instructions are imprecise.

- 2.4 The JAA have published JAA Administrative and Guidance Material, Section One: General Part 3: Temporary Guidance Leaflet (TGL) number 17: Passenger Service and In-Flight Entertainment (IFE) Systems. This document provides guidance for the certification of new IFE designs. The CAA supports the use of this document. However, it has been identified that it does not provide comprehensive information regarding the development of installation instructions, standards and ICAW.
- 2.5 Applicable certification codes will typically lead the assessment of IFE to be a “nonessential” system. As such the system will only be subjected to limited system safety assessment and will not initiate the traditional maintenance task development processes. The service failures seen in practice would certainly appear to suggest that this ‘no additional-maintenance required’ assumption is invalid. Where appropriate, maintenance tasks should be identified to ensure system integrity. This is discussed further in Appendix 1 to this Leaflet.

3 Objective

This Leaflet has been issued to supplement JAA TGL 17 and to provide additional guidance to industry in order to ensure that:

- a) initial installation standards and instructions are clear and concise and demonstrate equality with aircraft manufacturers’ production standards;
- b) clear “overall” continued airworthiness responsibility is defined. There should be robust and co-ordinated ICAW data developed and published. Such data should cover the interface between IFE modifications and original design to ensure repeatable in-service removal and re-installation standards are achieved during scheduled maintenance and defect rectification;
- c) a logical method to develop IFE maintenance tasks and solutions is utilised; and
- d) IFE scheduled maintenance tasks are integrated into the Approved Maintenance Programme (AMP). Existing tasks to be reviewed and amended and when identified via the methodology above, the new IFE related tasks included.

4 Applicability

4.1 New IFE Installations

All new IFE installations and modifications should take account of and meet the intent of this Leaflet together with the JAA TGL 17.

NOTE: EASA will be transcribing the TGL into their publications in the near future.

4.2 Existing IFE installations

It should be noted that Commission Regulation (EC) NO 2042/2003, Part M.A.302 came into force on 28 September 2005. This particular requirement outlines what is expected to be included in an approved maintenance programme. With regard to M.A.302 (c) 2 this Leaflet provides the competent authority instructions, specific to IFE installations, which should be addressed as part of the periodic programme review.¹ It is therefore expected that the applicable aspects of this Leaflet be incorporated in the programme within one year of publication of this Leaflet to comply with the requirements of Part M.A.302.

1. This statement originally applied to AN 60 which was published in September 2005.

5 Recommendation

5.1 In order to address the above concerns and objectives it is recommended that project management practices be utilised to ensure appropriate compliance with certification codes, development of applicable and effective ICAWs and scheduled maintenance tasks.

5.2 An individual should be identified to the CAA who would fulfil the role of project manager. It is expected that the project manager holds a suitable position within an approved organisation, and, if not within the operator's organisation, this role is contractually linked to the operator.

5.3 A prime objective of the project should be to address the issues in paragraph 3. All stakeholders should be identified, these would include, as a minimum, the CAA, all the design organisations involved in the total installation, the aircraft manufacturer (where appropriate), equipment manufacturers (where appropriate), the installing organisation and the operator.

5.4 Considerations for Project Manager

The IFE system project plan should manage, as a minimum, compliance with the following:

- a) Definition of the whole IFE Installation, e.g. the STCs - how many, their approval basis, compatibility with TC and other STC(s), continued airworthiness responsibilities etc.
- b) The installing organisation – that they have the necessary approvals, competence, facilities, equipment etc. (with respect to the installation in question).
- c) Specific aircraft being modified - effect on particular airframe e.g. documents to be amended, maintenance programme amendment. Validation of all proposed documentation changes.
- d) Operational considerations – e.g. Crew operating instructions and training (including any normal, abnormal and emergency procedures), limitations of use etc.
- e) Stakeholders – establish communication links and identify all the relevant parties to ensure full and complete liaison with respect to their role in the whole IFE installation.
- f) Timeline – identification of specific milestones in the process, e.g. Agreed times to involve/contact CAA, what should be presented at these times etc.
- g) Development of Scheduled Maintenance and Maintenance Instructions – who will be responsible for doing this and the methodology to be utilised. (See Appendix 1 for guidance.)
- h) Ensure all stakeholders understand their role in order to achieve compliance with this Leaflet.

5.5 Considerations for Designer

The Designer for an IFE System should consider, as a minimum, the following key areas:

- a) Establish communication links with the project manager and the relevant stakeholders.
- b) Ensure that all installation instructions, operating conditions and equipment limitations (e.g. European Technical Standard Order (ETSO) and Declaration of

Design and Performance (DDP)) are considered and recorded in the appropriate drawings/manuals etc.

- c) It is expected that the designer will provide installation instructions (engineering drawings) that as a minimum equate to the original aircraft production standards. Statements such as “install in accordance with industry standard practices,” would be unacceptable. It is considered that such statements are inadequate because the standard practices cannot alone define the location, routing or security of electrical wiring for example.
- d) Identify any features that are believed to require new or amended scheduled maintenance tasks and participate in the scheduled maintenance task analyses. (See Appendix 1 for guidance.)
- e) Ensure that all appropriate Airworthiness/Operational data is produced in sufficient time for the operator to incorporate into relevant manuals prior to entry into service. This should include normal, abnormal and emergency procedures.
- f) IFE installations (equipment or wiring) may affect existing TC/STC Holder derived maintenance tasks. The designer should assess, in accordance with original scheduled AMP development processes, the effect of the modification on the existing maintenance tasks and inspections, and address accordingly.
- g) Validated maintenance instructions to be produced so that the original installation standards are maintained after in-service activities.
- h) Establishment of engineering liaison processes to address minor change requests required during installation, and to monitor and react to operator in-service reliability feedback.

5.6 **Considerations for Installer**

The installer of an IFE system should manage, as a minimum, compliance with the following:

- a) Establish communication links with the project manager and the relevant stakeholders.
- b) A verified internal competence and capability assessment should be carried out against the specific installation requirements. This should cover, as a minimum, any necessary unique skills, technologies, tools and training. Installer’s competence/scope should be described within the Part-145 Maintenance Organisation Exposition (MOE).
- c) The pre-planning function should seek to identify any shortcomings within the installation instructions prior to installation on the aircraft, and to report to the relevant stakeholders for resolution.
- d) Provide feedback and gain approval of minor installation and instruction/drawing changes found during installation.

5.7 **Considerations for Operator**

The operator of an aircraft installed with an IFE system should manage, as a minimum, compliance with the following:

- a) Establish communication links with the project manager and the relevant stakeholders.
- b) To update the existing Continuing Airworthiness (CAW) management processes to ensure that lines of communication with all of the IFE STC holders are

established. These links are to be maintained to ensure that changes to relevant stakeholders are known during the in-service life of the IFE installation.

- c) Prior to entry into service, operational procedures and crew training should be accepted by the CAA.
- d) Participate in the scheduled maintenance task analyses. Amend existing tasks and create new tasks as appropriate for addition to the AMP in collaboration with the TC/STC holder(s) and project manager. This must be approved by the CAA prior to entry into service. (See Appendix 1 for guidance.)
- e) Establish an effective IFE reliability system to feedback data to the TC/STC holder(s) to ensure that the CAW of the installation is maintained at the intended design standard. If necessary this will then produce additional changes to the ICAW.

6 Conclusion

As the expectation is that the project manager will be employed by an approved organisation, this project management will form part of the routine oversight of the approval by the CAA, when an IFE project is undertaken. The project manager should liaise with the Surveyor assigned to the organisation approval at an early stage to apprise them of the project definition and proposed plan. This will facilitate early identification of the appropriate CAA personnel to ensure all aspects are efficiently overseen. Review of continuing compliance with the relevant aspects of this Leaflet will form part of routine operator and design organisation oversight by CAA.

INTENTIONALLY LEFT BLANK

Appendix 1 Guidance on the Development of IFE Scheduled Maintenance Tasks and Solutions

1 Introduction

As stated in paragraph 2 of this Appendix, current certification codes when applied to the installation of operator optional systems may not provide the necessary cohesion to initiate the current industry standard practice for scheduled maintenance development (e.g. application of Maintenance Steering Group-3 (MSG-3) logic, that would result in an amendment to the Maintenance Review Board Report (MRBR)). Service experience has shown that a large number of IFE related reported occurrences were smoke/fire events caused by an ignition source within the IFE system. This type of failure consequence is clearly a safety concern and needs to be addressed when identifying applicable and effective scheduled maintenance and maintenance instructions. Recognising that Passenger Services and IFE modifications will not normally trigger involvement of the relevant Maintenance Review Board, the following guidance is considered an acceptable means to develop appropriate maintenance controls for such systems.

2 Procedure

- 2.1 In order to apply the logic in the following flowchart there are certain precursors to understand. Design features within the modification where failure or damage may exist and could result in a degradation of system function or a safety concern are designated Maintenance Significant Items (MSI). MSIs are identified from asking the following questions:
- Could the failure of this item be undetectable or not likely to be detected by the operating/cabin crew during normal duties?
 - Could the failure affect safety on the ground or in flight?
 - Could the failure or combination of failures have a significant effect on operations?
 - Could the failure or combination of failures have a significant economic impact?
- 2.2 For each MSI the function, functional failure, failure consequence and failure cause should be identified:
- Function** is the chosen design solution to prevent undesirable failure consequences e.g. insulation function, cooling function etc.
 - Functional failure** is the failure of a chosen design solution to perform the intended function.
 - Failure consequence** is the result of the functional failure. The most significant failure consequences are the presence of an ignition, heat or electric shock source that could lead to smoke/fire or passenger injury.
 - Failure cause** is the reason for the functional failure e.g.
 - Wiring prone to damage;
 - Components susceptible to fluid spill;
 - Dust/debris contamination causing overheating;

- Components prone to overheat;
- Passenger traffic damage;
- Components subject to frequent removal/replacement;
- Poor electrical bonding;
- Mechanical breakdown due to wear.

(List not exhaustive.)

2.3 **Development of Scheduled Maintenance Tasks and Solutions**

Once the functions and functional failures have been identified the series of questions contained in the following flowchart should be asked to determine the applicable and effective scheduled maintenance task and/or solutions to mitigate/prevent the failure of a chosen design solution. This development should be accomplished with the collaborative effort of the TC/STC Holder(s), operator and project manager as appropriate.

2.4 **Guidance on how to use the Flowchart**

Box 1

This question must be asked for each functional failure of the chosen design solution being analysed. The intent is to segregate the evident and hidden functional failures. The operating crew consists of qualified flight compartment and cabin attendant personnel who are on duty. Normal duties are those duties associated with the routine operation of the aircraft on a daily basis.

Box 2

Failure consequences to consider are those previously described e.g. ignition, heat or electric shock.

Box 3

The failure in question does not directly affect safety and therefore the issue is one of reliability and/or passenger convenience. The analyst should discuss this with the operator and address the failure as necessary.

Box 4

The question takes into account failure(s) in which either the single hidden/dormant failure (from Box 1) or in combination with one additional failure could cause one of the identified undesirable consequences.

Box 5

This is to propose various applicable and effective tasks and/or preventative actions, either singularly or in combination, for the analyst to identify:

(5a) Inspection – either:

- Detailed (An intensive examination of a specific item, installation or assembly to detect damage, failure or irregularity. Available lighting is normally supplemented with a direct source of good lighting at an intensity deemed appropriate. Inspection aids such as mirrors, magnifying lenses, etc. may be necessary. Surface cleaning and elaborate access procedures may be required).

Or

- General Visual (A visual examination of an interior or exterior area, installation or assembly to detect obvious damage, failure or irregularity. This level of inspection

is made from within touching distance unless otherwise specified. A mirror may be necessary to enhance visual access to all exposed surfaces in the inspection area. This level of inspection is made under normally available lighting conditions such as daylight, hangar lighting, flashlight or drop-light and may require removal or opening of access panels or doors. Stands, ladders or platforms may be required to gain proximity to the area being checked.)

(5b) Functional Check

- A quantitative check to determine if one or more functions of an item performs within specified limits.

(5c) Restoration Task

- That work necessary to return the item to a specific standard. Restoration may vary from cleaning or replacement of single parts up to a complete overhaul.

(5d) Discard

- The removal from service of an item at a specified life limit.

(5e) Update Maintenance Practice/instructions

- Amend standard practices (either company or manufacturers) or update maintenance manuals to provide additional guidance or precautions/warnings.

(5f) Training

- Update or introduce training programmes to address identified knowledge shortfalls in crew, maintenance and/or support staff.

(5g) Design/Modification

- Identification of a shortcoming within the design that requires correction and subsequent modification.

Box 6

If any (or combination of) boxes 5a, 5b, 5c, and 5d are selected the task(s) should be included in the operators approved maintenance programme. This will require approval by the CAA.

Box 7

If 5e is considered the applicable and effective solution then the necessary documents should be amended and validated e.g. Maintenance Manual, Wiring Diagram Manual, Standard Practices Manual, Component Maintenance Manual.

Box 8

If training has been considered the applicable and effective solution, then the appropriate training should be identified and implemented via a documented training needs analysis.

Box 9

If the identified solution rests with a redesign then this must be accomplished via an approved process.

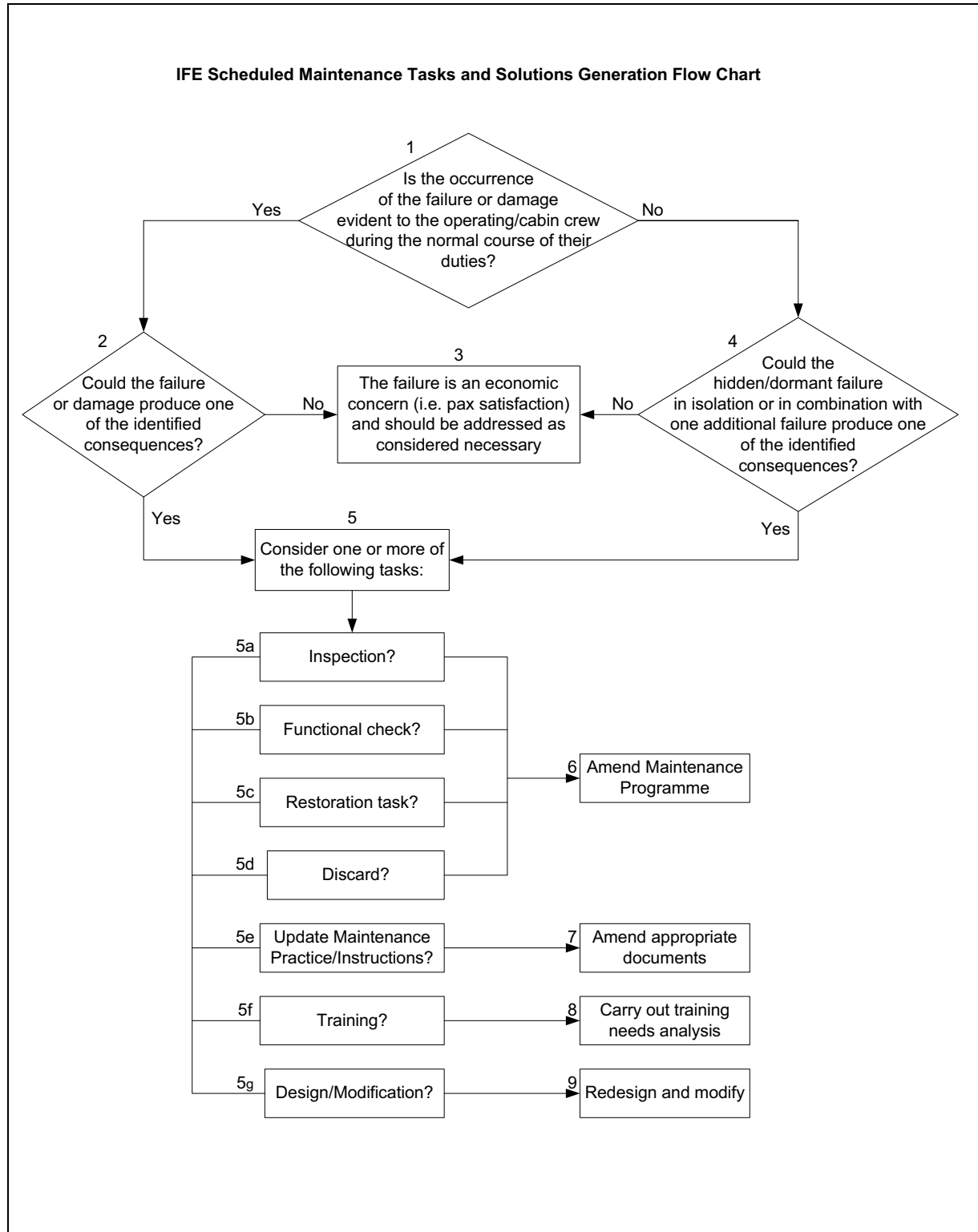

Leaflet 44-20 Aircraft Security, Flight Crew Compartment Monitoring Systems

1 Purpose

This Leaflet provides guidance for approval where cabin mounted video cameras in conjunction with flight deck displays are used.

NOTE: This Leaflet does not cover the Performance and Operational aspects of the monitoring systems. The CAA Flight Operations Department will address these aspects by installation appraisal and via a 'Special Communication'.

2 References

The following list is for guidance purposes only. The applicable requirements will depend upon the aircraft in which monitoring systems are to be installed. Although EASA CS-25 has been referenced for large public transport aircraft similar requirements can be read across to EASA CS-23 for smaller aircraft.

CS 25.561 – Emergency Landing Conditions – General

CS 25.773 – Pilot compartment view

CS 25.777 – Cockpit controls

CS 25.785 – Seats, berths, safety belts and harnesses

CS 25.789 – Retention of items of mass in passenger and crew compartments and galleys

CS 25.803 – Emergency Evacuation

CS 25.853 – Compartment Interiors

CS 25.869 – Fire Protection Systems

CS 25.1301 – Function and installation

CS 25.1309 – Equipment, systems and installations

CS 25.1333 – Instrument systems

CS 25.1351 – General

CS 25.1353 – Electrical equipment and installations

CS 25.1357 – Circuit protective devices

CS 25.1360 – Precaution against injury

CS 25.1523 – Minimum flight crew

CS 25.1529 – Instructions for Continued Airworthiness

CS 25.1555 – Control markings

TGM/21/07 – Electrical Wiring Policy

3 Introduction

3.1 ICAO Annex 6 Chapter 13 now includes a requirement such that appropriate means shall be provided for monitoring from either pilot's station the area outside the flight

crew compartment so as to identify persons requesting entry and to detect suspicious behaviour or potential threat.

- 3.2 This Leaflet provides a summary of policy and advisory material that should be applied when certifying the installation aspects of monitoring systems with flight deck display on aircraft. This policy has been derived from FAA policy as stated in FAA memorandum 01-111-196 dated October 5 2001.
- 3.3 Monitoring systems equipment is to be qualified approved as part of the overall modification to the aircraft in which it is to be installed.

4 Electrical Installation Considerations

The key aspects for the installation are as follows:

- a) In accordance with CS 25.1301, the monitoring system should be of a kind and design appropriate to its intended function, and should function properly when installed. The key words to understand the intent of this regulation are “appropriate” and “properly”, as they relate to airworthiness. To be “appropriate” means that the equipment is used in a manner for which it was designed. To function “properly” means that the monitoring system should not interfere with the ability of the aeroplane and flight crew to continue safe flight, landing, and egress.
- b) The monitoring system components and wiring should meet the flammability requirements of CS 25.853 and 25.869.
- c) Monitoring system wire should be installed in accordance with the wiring standards established by the original aeroplane manufacturer and in accordance with the JAA/EASA Guidance Material TGM/21/07.
- d) An electrical load analysis, based on the most recent electrical load configuration for the aeroplane should be accomplished in accordance with CS 25.1351(a).
- e) Monitoring system wiring should be protected by appropriately rated circuit breakers in accordance with CS 25.1357.
- f) System separation should not be compromised by the installation of the monitoring system (reference CS 25.1353(a)).
- g) Required instrument systems should not be compromised by the installation of the monitoring system (reference CS 25.1333(c)).
- h) Laboratory, ground and flight testing for electromagnetic interference should be accomplished, as appropriate.
- i) The monitoring system should be connected to an electrical bus that **does not** supply power to aeroplane systems that are necessary for continued safe flight and landing. System designers should be encouraged to select lower level electrical buses (e.g. utility, galley, ground service bus, etc.).
- j) A means should be provided for the flight crew to manually disconnect the monitoring system from its source of power. The removal of power should occur as close to the bus supplying power as possible. The disabling/deactivating of component outputs is not considered an acceptable means to remove power (i.e., disabling/deactivating the output as opposed to removing input power to the system).

NOTE: The ability to remove monitoring system power should not be provided outside of the flight deck (i.e., no control of the monitoring system within the passenger cabin).

- k) Reliance on pulling system circuit breakers (CBs) as the sole means to remove monitoring system power is not acceptable. The use of a CB as a switch will degrade the CB's ability to trip at its rated current trip point.
- l) The design and installation of the monitoring system should be such that impact upon operational procedures is minimised. However, the Aeroplane Flight Manual (AFM) must address any changes to normal, abnormal, and emergency procedures that are due to the installation of the monitoring system.
- m) CS 25.1529, Instructions for Continued Airworthiness, and any information and instructions to be contained in the MMEL should be addressed.

5 Construction and Attachment Strength Considerations

Monitoring equipment, attachments and supporting structure should be constructed such that the constituent parts do not break loose when subjected to the loads (both flight and emergency alighting) prescribed in the appropriate sections of the Certification Specifications. Commercial equipment may not comply with these requirements and may need to be strengthened before being installed in an aircraft.

The monitoring equipment has, as far as is practicable, to be so positioned that, if it should break loose, it will be unlikely to cause injury or nullify escape facilities provided for use after an emergency landing or alighting on water. When such positioning is not practicable each such item of equipment shall be restrained under all loads up to the prescribed ultimate inertia forces for the flight and emergency landing conditions.

NOTE 1: The structural requirements applicable to equipment can vary dependent upon the type and size of the aircraft in which it is to be installed. If the equipment is designed to be installed in any aircraft then all the relevant airworthiness codes will need to be consulted and an envelope of conditions determined for design purposes.

NOTE 2: The installer will need to consult the original aeroplane manufacturer to obtain data on the vertical acceleration factors (resulting from gusts and aircraft manoeuvres) applicable to the aircraft type and the proposed equipment location.

6 Flight Deck Human Factors Issues Associated with Installation of Monitoring System (To Allow Viewing of Cabin by Flight Crew)

The primary issue is to ensure that installation does not compromise usability of existing systems. The use of the monitoring system, in accordance with the proposed operating procedures, should not result in pilot distraction or workload that may unacceptably compromise pilot performance of other required tasks. If the system provides audio in addition to video, that audio should not interfere with required pilot communication, nor should it interfere with the detection and identification of aural alerts. The monitoring system should be de-activated during take-off, approach and landing conditions.

There are two categories of installations to be considered:

a) Standalone

The first category is a separate video display that is not integrated with existing approved, essential flight deck display systems. This category also includes installations that use the video display unit associated with other non-required, non-safety-related displays (e.g. maintenance displays).

Issues associated with standalone installations: These issues result from the installation of new controls and displays in the flight deck.

- i) Ensure that the video display unit does not produce unacceptable glare or reflections on the existing essential/critical displays or on the flight deck windows, under all expected lighting conditions. See also CS 25.773(a)(2);
- ii) Ensure that the installation does not place the controls for the camera system in locations that may result in inadvertent operation of other controls (i.e. when the pilot reaches for the camera control it is likely that some other control may be “bumped” and repositioned). See also CS 25.777(a);
- iii) Since this system is likely to be needed a number of times during a flight, ensure that the pilots can operate/view any controls and displays (that are to be used in flight) from their normally seated positions. See also CS 25.785(g);
- iv) Ensure that any cockpit mounted video display unit would not hinder crew emergency escape provisions. See also CS 25.803.

b) **Integrated**

Systems in which the video from the cabin camera is routed to existing approved, essential/critical displays (e.g. main panel multifunction displays, Flight Management System (FMS) control/display units) and/or the audio system.

Issues associated with integrated installations: In such installations, it is expected that the issues above will be less significant (even though they are applicable), because such an installation is likely to use previously approved controls and/or displays. In addition, the following issues should be considered:

- i) The camera system and its use should not interfere with the intended function and use of other essential/critical functions with which it shares displays and/or controls (e.g. viewing the video from the camera should not prevent or unacceptably interfere with the display of other required information, such as flight or navigation data). See also CS 25.1301(a);
- ii) Integration of the camera system controls and displays should not result in confusion in the labelling or operation of other required systems (e.g. the nomenclature of control functions should not be similar to existing nomenclature to the extent that confusion could result). See also CS 25.777(a), CS 25.1555(a).

7 Further Information

For Airworthiness Certification aspects further information may be obtained from:

Engineering Department
Safety Regulation Group
Aviation House
Gatwick Airport South
West Sussex
RH6 0YR
Tel: +44 (0)1293 573134

Leaflet 44-30 Helicopter Emergency Escape Facilities

PURPOSE: To provide guidance on interpretation of the requirements and recommended standards for emergency escape facilities for use should the helicopter capsize after a ditching.

REFERENCES: BCAR Chapter G4-3
BCAR Blue Paper G779 paragraph G4-3, 5.2.7
CAA Direction to Offshore Helicopter Operators dated 18 October 1985
Air Navigation Order 2016 (as amended) Article 106(4)(c)
JAR OPS 3. 837(a)(4) and (6)
CAT.IDE.H.275
SPA.HOFO.165(h), AMC1 SPA.HOFO.165(h),
GM1 SPA.HOFO.165(h)
CS 29.811(h), AMC 29.811(h)

1 Introduction

As long as the probability of a helicopter sinking or capsizing subsequent to ditching remains at a significant level, it is considered that it is necessary to improve the chances of escape from a submerged or partially submerged cabin in this situation. Following consultation with industry, it has been agreed that some aspects of the survival systems of the current helicopter fleet can be improved, and as a result the appropriate regulations and requirements have been amended.

This Leaflet addresses three of these aspects, namely improved emergency exit illumination, provision of additional escape routes, and security of loose articles, and gives guidance on interpretation and acceptable means of compliance.

2 Emergency Lighting

All helicopters being used in support of offshore energy exploitation have been required to comply with BCAR Chapter G4-3, 5.2.7 as amended by Blue Paper G779, or JAR OPS 3.837 (a)(4) which requires emergency exit illumination to be adequate for its purpose even when the aircraft is capsized and the cabin partially or completely submerged. Additionally, some cabin windows are of a suitable size to provide an additional escape route and, as required by the CAA Direction, or JAR OPS 3.837 (a)(6) must be made openable. (See 3 below). Although not a requirement, lighting for these 'escape windows' can be installed provided it does not reduce the effectivity of the emergency exit illumination.

NOTE 1: JAR OPS 3 was replaced by the EASA Air Operations Regulation and, from 01 July 2018, emergency exits and escape hatches are covered by CAT.IDE.H.275 and SPA.HOFO.165(h). The material contained in this leaflet remains extant for helicopters operated under the EASA Air Operations Regulation that are not certificated to CS 29 Amendment 5 or later.

NOTE 2: For helicopters certificated to CS 29 Amendment 5 or later, emergency exit marking (including lighting) is covered by CS.29.811 (h) and AMC 29.811(h), which supersedes the material contained in this leaflet for such helicopters.

2.1 Emergency Exit Lighting

Lighting systems should incorporate the following features and characteristics:

a) Activation

In principle at least two separate means of activation should be provided:

- i) by flight crew action, to switch all exit light systems simultaneously; and
- ii) automatically, when the cabin becomes more than half submerged in water, each emergency exit being provided with its own automatic switch.

NOTE 1: Where it is impracticable to provide for remote activation of an individual exit lighting, for example where the emergency exit is inset into a door, a self-contained automatic activation alone will be acceptable.

NOTE 2: Flight crew compartment emergency exit lights should only be activated automatically, unless it can be shown that reflections or dazzle will not be a hazard to the flight crew.

b) Lighting System Characteristics

- i) Lights should operate at their full brightness level for a minimum of 10 minutes after activation.

NOTE: Battery capacity should take account of the need for routine testing of the light system.

- ii) The system should remain fully operational when submerged to a depth of at least 50 feet.
- iii) Power supplies must comply with the existing requirements for emergency lighting power supplies.
- iv) The system should be designed so that any single transverse vertical separation of the fuselage will not result in the loss of exit lights not directly damaged by the separation.

c) Format

- i) Generally, all sides of each emergency exit should be equally illuminated, except that, where one side of the exit is at floor level, this side need not be illuminated.
- ii) For passenger compartment emergency exits, there must be sufficient light to locate the means of release of the exit. This will normally entail the provision of a discrete locator light adjacent to the exit release means.
- iii) Brightness should be such that the exit can be identified as such from a distance of at least 20 feet in clear water, without any additional light from other sources.

2.2 Escape Window Lighting

It is recommended that these lighting systems incorporate the following features and characteristics:

- a) **Activation.** This should be in a similar manner to emergency exit lighting activation, except that no manual control need be provided, and each window lighting system should be completely independent wherever possible.

- b) **System Characteristics.** These should be similar to the emergency exit lighting system, except that escape windows are only intended for use by occupants in their immediate vicinity. Illumination therefore need only be adequate to allow occupants of the immediately adjacent seats to identify the opening and its means of release.
- c) **Format**
- i) There should be no possibility of confusion between an emergency exit and an escape window.
 - ii) The arrangement of the lighting elements should direct an occupant to the centre of the aperture, and should avoid confusion with any spaces between apertures or exits.

3 **Escape Windows**

- 3.1 Escape windows should be provided in accordance with SPA.HOFO.165(h), including AMC1 SPA.HOFO.165(h) and GM1 SPA.HOFO.165(h).

4 **Security of Baggage**

- 4.1 Article 106(4)(c) of the Air Navigation Order 2016 (as amended) requires the pilot in command of an aircraft ‘...to take all reasonable steps to ensure that those items of baggage in the passenger compartment which the pilot in command reasonably considers ought by virtue of their size, weight or nature to be properly secured are properly secured.....’.
- 4.2 CAT.OP.MPA.160 “Stowage of baggage and cargo”, together with AMC 1 and 2, place similar requirements on the Operator.
- 4.3 In the case of helicopters operated for offshore energy exploitation support, this regulation should be interpreted as referring to all items of baggage which, if unsecured, might obstruct the occupants escape from the aircraft in the event of a capsize or flooded cabin following a ditching. For this reason no baggage or other loose articles of significant size or weight should be carried in the passenger compartment unless secured so that they cannot move from their secured location in an emergency, even if the aircraft becomes inverted and/or the cabin fills with water.

INTENTIONALLY LEFT BLANK

Chapter 51 Standard Practices and Structures – General

Leaflet 51-10 Inspection of Wooden Structures

1 Introduction

- 1.1 This Leaflet gives guidance on the inspection of wooden aircraft structures for evidence of deterioration of the timber and glued joints. It should be read in conjunction with the relevant aircraft manuals, approved Maintenance Schedules and manufacturers' instructions, from which details of particular structures may be obtained.
- 1.2 Information on the conversion of timber into aircraft parts is given in Leaflet 51-30 and on the use of synthetic resin adhesives in Leaflet 51-40.

2 CAA Policy

CAAIP Leaflet 51-20 describes the extent of the deterioration which has been found in wooden structures and the dismantling which may be necessary to enable thorough inspections to be carried out.

- 2.1 While Leaflet 51-20 expresses concern at the extent of deterioration found in some aircraft, it is also pointed out that there is no reason why aircraft manufactured in these materials should not have a satisfactory life provided they are protected from the adverse effects of extreme temperature and humidity and are kept in suitable hangars when not in use.

3 Glued Structures

Provided that protective varnish was applied to all exposed wood surfaces after gluing and satisfactorily maintained during the life of an aircraft, rapid deterioration of timber and glued joints would be unlikely. However, access to internal structure is often difficult or even impossible and deterioration takes place for a variety of reasons.

- 3.1 Some of the main factors which may cause deterioration are:
 - a) Chemical reactions of the glue itself due to ageing or moisture, to extremes of temperature or to a combination of these factors.
 - b) Mechanical forces due mainly to timber shrinkage.
 - c) Development of mycological growths (i.e. fungus).
 - d) Oil percolating from the engine installation.
 - e) Fuel contamination due to system leaks or spillage in the tank bays.
 - f) Blockage of water drainage holes.
- 3.2 Aircraft which are exposed to large cyclic changes of temperature and humidity are especially prone to timber shrinkage which in turn may lead to glue deterioration. The amount of movement of timber members due to these changes varies with the

volume of each member, the rate of growth of the tree from which the timber was cut and the way in which the timber was converted. Thus, two major members in an aircraft structure, secured to each other by glue, are unlikely to have identical characteristics and differential loads will, therefore, be transmitted across the glue film with changes of humidity. This will impose stresses in the glued joint which, in temperate zones, can normally be accommodated when the aircraft is new and for some years afterwards. However, with age the glue tends to deteriorate, even when the aircraft is maintained under ideal conditions and stresses at the glued joint, due to changes in atmospheric conditions, may cause failure of the joint.

- 3.2.1 In most wooden aircraft of monoplane manufacture the main spars are of box formation consisting of long top and bottom transverse members (i.e. spar booms) joined by plywood webs. The spar booms may be built up from laminations glued together and at intervals vertical wooden blocks are positioned between the two booms to add support to the plywood sides.
- 3.2.2 The main spars carry most of the loads in flight and are, at times, subject to flexing. The glued joints should, therefore, be free from deterioration but, unless the spar is dismantled or holes cut in the webs, internal inspection may be virtually impossible.
- 3.2.3 Long exposure to inclement weather or strong sunlight will tend to destroy the weatherproofing qualities of fabric coverings and of surface finishes generally. If fabric-covered ply structures are neglected under these conditions the surface finish will crack, allowing moisture to penetrate to the wooden structure and resulting in considerable deterioration through water soakage.

4 Survey of Structure

Before commencing a detailed examination of an aircraft structure, the aircraft should be inspected externally for signs of gross deformation, such as warped wing structures, tail surfaces out of alignment or evidence of obvious structural failure. In some cases of advanced deterioration this assessment may be sufficient to pronounce the aircraft beyond economical repair and thus avoid further work.

- 4.1 Whenever possible the aircraft should be housed in a dry, well ventilated hangar and all inspection panels, covers and hatches removed before continuing with the survey. The aircraft should be thoroughly dried out before examining glued joints or carrying out repairs.
 - 4.1.1 Immediately after opening the inspection panels, etc., each component should be checked for smell. A musty smell indicates fungoid growth or dampness and, if present, necessitates further examination to establish which areas are affected.
 - 4.1.2 Where the wings, fuselage or tail unit are designed as integral stressed structures, such as inner and outer ply skins glued and screwed to structural members (Figure 1) no appreciable departure from the original contour or shape is acceptable.

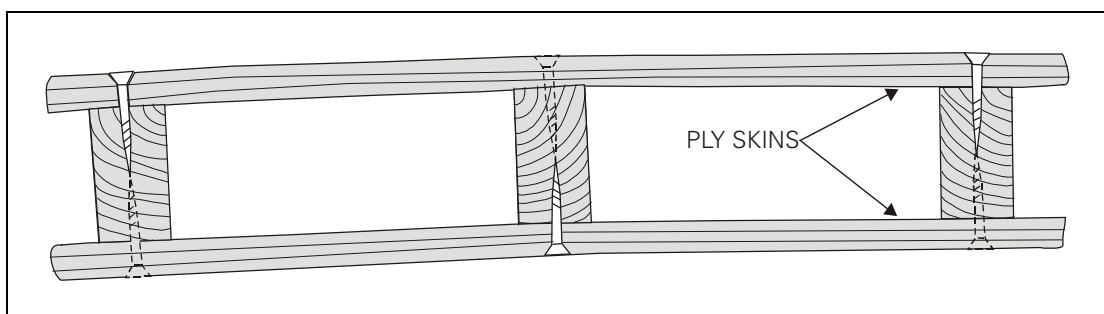

Figure 1 Double Skin Structure

- 4.1.3 Where single skin plywood structures are concerned, some slight sectional undulation or panting between panels may be permissible provided the timber and glue is sound. However, where such conditions exist, a careful check must be made of the attachment of the ply to its supporting structure and moderate pressure with the hand, to push the ply from the structure, should be used. A typical example of a distorted single skin structure is illustrated in Figure 2.

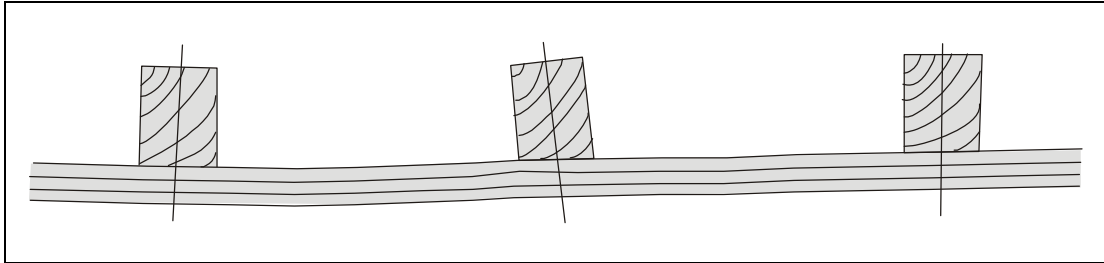

Figure 2 Single Skin Structure

- 4.1.4 The contours and alignment of leading and trailing edges are of particular importance and a careful check should be made for deformities. Any distortion of these light ply and spruce structures indicates deterioration and a careful internal inspection should be made for security of these parts to the main wing structure. If a general deterioration is found in these components the main wing structure may also be affected.
- 4.1.5 Where there are access panels or inspection covers on the top surfaces of wings or tailplane, care is necessary to ensure that water has not entered at these points where it can remain trapped to attack the surrounding structure.
- 4.2 Splits in the proofed fabric covering on plywood surfaces should be investigated by removing the defective fabric in order to ascertain whether the ply skin beneath is serviceable. It is common for a split in the ply skin to be the cause of a similar defect in the protective fabric covering.
- 4.3 Fabric having age cracks and thick with repeated dopings, may indicate that the structure underneath has not been critically examined for a considerable time. Insertion patches in the fabric could also indicate that structural repairs have been made at that point.
- 4.4 Whilst a preliminary survey of the external structure may be useful in roughly assessing the general condition of the aircraft, it should be noted that timber and glue deterioration often takes place inside a structure without any external indications. Where moisture can enter a structure, it will tend to find the lowest point, where it will stagnate and promote rapid deterioration. Other causes of glue deterioration are listed in paragraph 3.1.

5 Inspection of Timber and Glued Joints

Assessment of the integrity of glued joints in aircraft structures presents considerable difficulties since there is no positive non-destructive method of examination which will give a clear indication of the condition of the glue and timber inside a joint. The position is made more difficult by the lack of accessibility for visual inspection.

- 5.1 The inspection of a complete aircraft for glue or wood deterioration will necessitate checks on remote parts of the structure which may be known, or suspected trouble spots and, in many instances, are boxed in or otherwise inaccessible. In such instances, considerable dismantling is required and it may be necessary to cut access

holes in ply structures to facilitate the inspection; such work must be done only in accordance with approved drawings or the repair manual for the aircraft concerned and, after the inspection has been completed, the structure must be made good and protected in an approved manner.

- 5.2 All known or suspected trouble spots must be closely inspected regardless of log book records indicating that the aircraft has been well maintained and properly housed throughout its life.

NOTE: Where access is required and no approved scheme exists, a scheme should be obtained from the aircraft manufacturer or an Organisation appropriately approved by the CAA/EASA for such work.

5.3 Access Holes

In general, access holes are circular in shape and should be cut with a sharp trepanning tool to avoid jagged edges. It is essential to avoid applying undue pressure to the tool, especially towards the end of the cut, otherwise damage may be caused to the inner face of the panel by stripping off the edge fibres or the ply laminations.

- 5.3.1 Where rectangular access holes are prescribed care is necessary to ensure that they are correctly located and that corner radii are in accordance with drawing requirements.

- 5.3.2 The edges of all access holes must be smoothed with fine glasspaper, preferably before inspection is commenced, since contact with the rough edges may cause wood fibres to be pulled away.

- 5.4 It is important that the whole of the aircraft structure, including its components, e.g. tailplane, elevators, etc., is inspected in detail before any decision is reached regarding general condition. It is possible for the main airframe to be in good condition but for a marked deterioration to have occurred in, for example, a control surface.

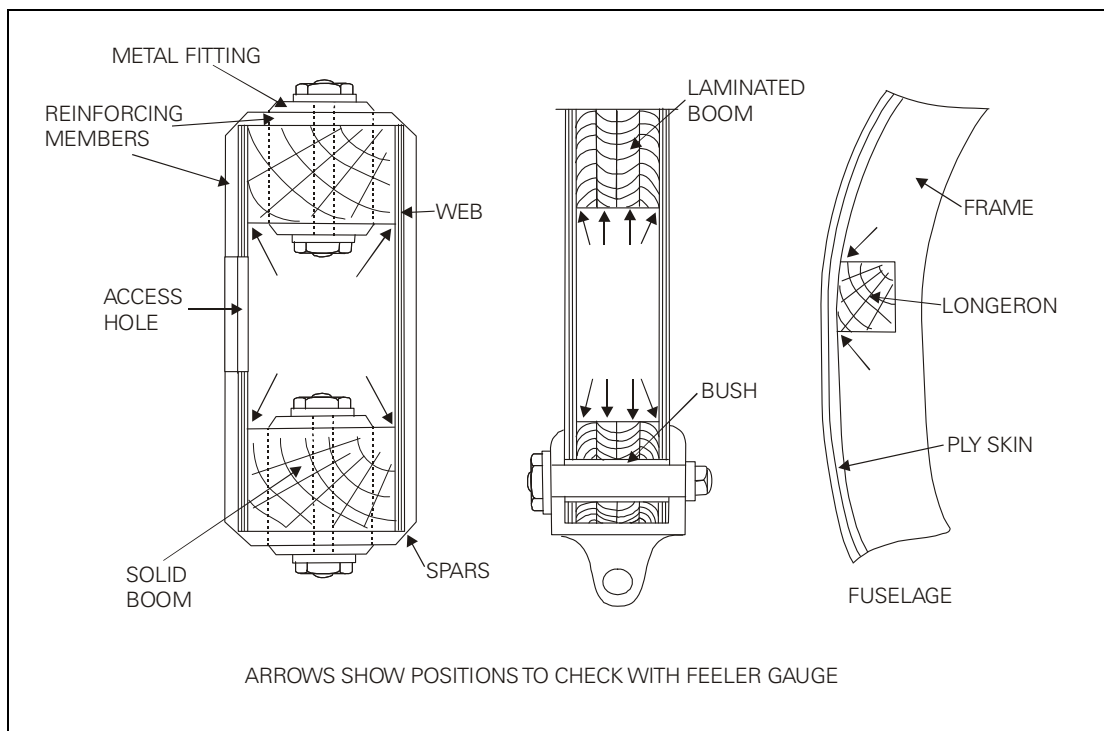

Figure 3 Glue Line Checks

5.5 Glue Line

When checking a glue line (i.e. the edge of the glued joint) for condition, all protective coatings of paint should be removed by careful scraping; it is important to ensure that the wood is not damaged during the scraping operation and scraping should cease immediately the wood is revealed in its natural state and the glue line is clearly discernible.

- 5.5.1 The inspection of the glue line is often facilitated by the use of a magnifying glass. Where the glue line tends to part or where the presence of glue cannot be detected or is suspect, then, providing the wood is dry, the glue line should be probed with a thin feeler gauge and, if any penetration is possible, the joint should be regarded as defective.

NOTE: It is important to ensure that the surrounding wood is dry, otherwise a false impression of the glue line would be obtained due to closing of the joint by swelling. In instances where pressure is exerted on a joint, either by the surrounding structure or by metal attachment devices such as bolts or screws, a false impression of the glue condition could be obtained unless the joint is relieved of this pressure before the glue line inspection is carried out.

- 5.5.2 The choice of feeler gauge thickness will vary with the type of structure, but a rough guide is that the thinnest possible gauge should be used. Figure 3 indicates the points where checks with a feeler gauge should be made.

5.6 Timber Condition

Dry rot and wood decay are not usually difficult to detect. Dry rot is indicated by small patches of crumbling wood, whilst a dark discolouration of the wood surface or grey streaks of stain running along the grain are indicative of water penetration. Where such discolouration cannot be removed by light scraping the part should be rejected, but local staining of the wood by the dye from a synthetic adhesive hardener can, of course, be disregarded.

5.6.1 Water Penetration of Structure

In some instances where water penetration is suspected, the removal of a few screws from the area in question will reveal, by their degree of corrosion, the condition of the surrounding joint (see Figure 4).

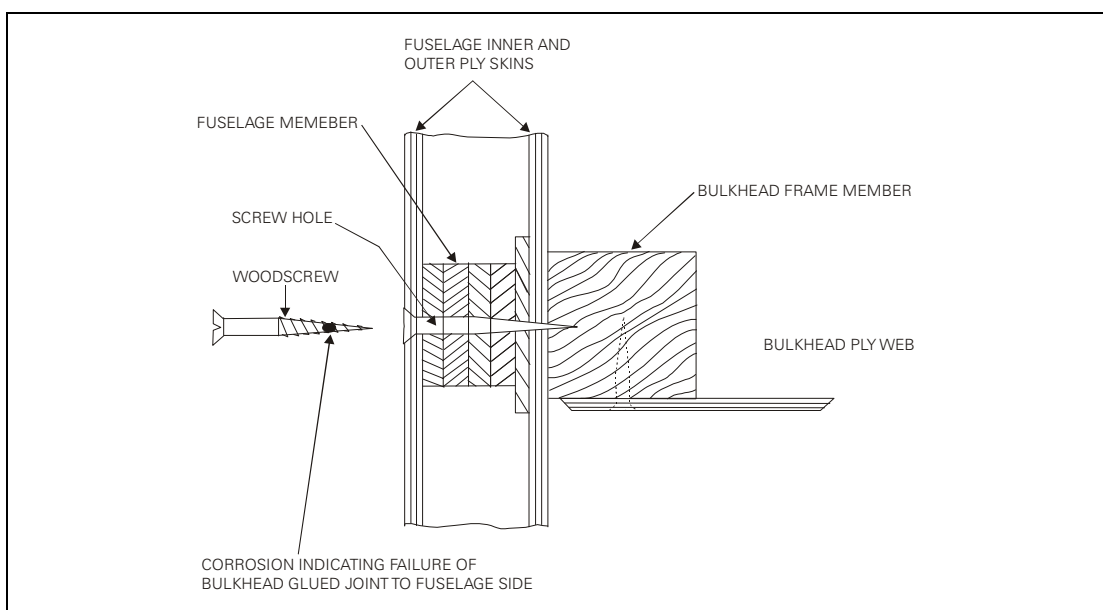

Figure 4 Check for Water Penetration

- a) Slight corrosion of the screw due to the adhesive will occur following the original manufacture, therefore, the condition of the screw should be compared with that of a similar screw, removed from another part of the structure known to be free from water soakage.

NOTE: Plain brass screws are normally used for reinforcing glued wooden members, although zinc coated brass is sometimes used. Where hard woods such as mahogany or ash are concerned, steel screws are sometimes used. Unless otherwise specified by the aircraft manufacturer, it is usual to replace screws with new screws of identical length but one size larger.

- b) Another means of ascertaining if water penetration has taken place is to remove the bolts holding fittings at spar root-end joints, aileron hinge brackets, etc. (see Figure 3). Primary joints may have bushed holes and the bushes should also be withdrawn. Corrosion on the surface of these bolts and bushes and timber discolouration, will provide a useful indication of any water penetration which has taken place. Bolts and bushes should be smeared with an approved protective treatment before being refitted through wooden members.

NOTE: When refitting bolts it is important to ensure that the same number of shrinkage washers are fitted as were fitted originally.

- c) Experience of a particular aircraft will indicate those portions of the structure most prone to water penetration and moisture entrapment (e.g. at window rails or the bottom lower structure of entry doors), but it must be borne in mind that this is not necessarily indicative of the condition of the complete aircraft.
- d) Where drain holes have become blocked, water soakage will invariably be found. Drain holes should be cleared during routine maintenance.

5.6.2 Water Penetration of Top Surfaces

As indicated in paragraph 3.2.3, the condition of the proofed-fabric covering on ply surfaces is of great importance. If any doubt exists regarding its proofing qualities or if there are any signs of poor adhesion, cracks, or other damage, it should be peeled back to reveal the ply skin.

- a) The condition of the exposed ply surface should be examined and if water penetration has occurred, this will be shown by dark grey streaks along the grain and a dark discolouration at ply joints or screw countersunk holes, together with patches of discolouration. If these marks cannot be removed by light scraping or, in the case of advanced deterioration, where there are small surface cracks or separation of the ply laminations, then the ply should be rejected. Where evidence of water penetration is found, sufficient of the surfaces should be stripped to determine its extent.
- b) Providing good care is taken of the protective covering from the beginning, much deterioration can be avoided.

5.6.3 Miscellaneous Defects

During the inspection of the aircraft, the structure should be examined for other defects of a more mechanical nature. Guidance on such defects is given in the following paragraphs.

- a) **Shrinkage.** Shrinkage of timber, as well as inducing stresses in glued joints, can cause looseness of metal fittings or bolts and, if fluctuating loads are present, can result in damage to the wood fibres at the edges of the fittings or around the bolt holes. Shrinkage can be detected by removing any paint or varnish as described in paragraph 5.5 and attempting to insert a thin feeler gauge between the timber and the fitting or bolt head.

- b) **Elongated Bolt Holes.** Where bolts secure fittings which take load-carrying members, or where the bolts are subject to landing or shear loads, the bolt holes should be examined for elongation or surface crushing of the wood fibres. The bolts should be removed to facilitate the examination and, in some cases, the bolt itself may be found to be strained. Rectification of elongated bolt holes must be carried out in accordance with the approved Repair Manual, the usual method being to open out the holes and fit steel bushes.
- c) **Bruising and Crushing.** A check should be made for evidence of damage such as bruises or crushing of structural members, which can be caused, for example, by overtightening bolts. Repair schemes for such damage are governed by the extent and depth of the defect.
- d) **Compression Failures.** Compression failures, sometimes referred to as compression 'shakes', are due to rupture across the wood fibres. This is a serious defect which at times is difficult to detect and special care is necessary when inspecting any wooden member which has been subjected to the abnormal bending or compression loads which may occur during a heavy landing. In the case of a member having been subjected to an excessive bending load, the failure will appear on the surface which has been compressed, usually at a position of concentrated stress such as at the end of a hardwood packing block; the surface subjected to tension will normally show no defects. In the case of a member taking an excessive direct compression load, the failure will usually be apparent on all surfaces. Where a compression failure is suspected, a hand torch shone along the member, with the beam of light running parallel to the grain, will assist in revealing this type of failure.
- e) **Previous Repairs.** When examining a structure for signs of the defects mentioned above, particular attention should be paid to the integrity of repairs which may have been carried out previously.

6 Joint Failure

A glued joint may fail in service as a result of an accident or due to excessive mechanical loads having been imposed upon it, either in tension or in shear. It is often difficult to decide the nature of the load which caused the failure, but it should be borne in mind that glued joints are generally designed to take shear loads.

- 6.1 If a joint is designed to take tension loads, it will be secured by a number of bolts or screws (or both) fairly closely pitched in the area of tension loading. If a failure occurs in this area, it is usually very difficult to form an opinion of the actual reasons for it, due to the considerable break-up of the timber occurring in close proximity with the bolts.
- 6.2 In all cases of glued joint failure, whatever the direction of loading, there should be a fine layer of wood fibres adhering to the glue, whether or not the glue has come away completely from one section of the wood member. If there is no evidence of fibre adhesion, this may indicate glue deterioration, but if the imprint of wood grain is visible in the glue this is generally due to 'case hardening' of the glue during manufacture of the joint and the joint has always been below strength. If the glue exhibits a certain amount of crazing or star shaped patterns, this indicates too rapid setting, or the pot life of the glue having been exceeded. In these cases, the other glued joints in the aircraft should be considered suspect.

NOTE: The use of a magnifying glass will facilitate the above inspections.

- 6.3 Damage caused by a heavy landing may be found some distance away from the landing gear attachment points. Secondary damage can be introduced by transmission of shock from one end of a strut or bracing to its opposite end, causing damage well away from the point of impact. A thorough inspection of the existing paint or varnish at suspected primary or secondary impact points may reveal, by cracks or flaking, whether damage has actually occurred.

Leaflet 51-20 Deterioration of Wooden Aircraft Structures

- 1 Concern over the susceptibility of wooden aircraft structures to deterioration, and recognition that extensive dismantling and inspection may be required to ensure their continued integrity was first expressed in Airworthiness Notices in 1957. In addition to wooden aircraft built in the United Kingdom, there is now a substantial number of foreign built wooden aircraft on the UK register.
- 2 Examination of older type wooden aircraft has highlighted several serious structural failures, and continued vigilance is therefore essential if the integrity of wooden aircraft structures is to be maintained. Deterioration has occurred in those assemblies where normal inspection is impossible and has not come to light until the adjacent structure has been disturbed to embody repairs or modifications, or during extensive overhaul. These closer examinations have revealed failure of glued joints in the primary structure and patches of timber in a state of decay as a result of exposure to extremes of atmospheric conditions.
- 3 General conclusions which have been drawn from the results of the examinations are:
 - a) the external appearance of wooden aircraft may give little or no indication of the condition of the timber and glued joints beneath the surface.
 - b) Aircraft built with glued ply and timber torsion box construction are the most vulnerable.
 - c) Under extreme conditions, deterioration can be very rapid indeed.
 - d) Lack of proper drainage can be a significant contributory factor, particularly when associated with c) above.
 - e) Many glues, especially those in use before 1950, lose strength with age and/or cycles of humidity and temperature.
- 4 Attention is drawn to the following:
 - a) Evidence to demonstrate that continued airworthiness has been established, means the aircraft records show that such aircraft have been dismantled, opened up and the upholstery removed to such an extent as to ensure that an adequate sample of timber and glued joints have been inspected and, if found to be defective, made good. In cases where defective timber and glued joints are found, it will be necessary to extend a sample of areas checked in order to establish confidence in the condition of the complete structure. This will apply to all wooden aircraft whether or not maintained to an approved maintenance schedule.
 - b) Wooden aircraft left continuously in the open or, conversely, stored for long periods in very dry conditions are particularly susceptible to deterioration. The type of storage provided for the aircraft must therefore be taken into consideration when assessing the amount of inspection necessary to meet the requirements of a) above.
 - c) Prospective purchasers of foreign registered aircraft are advised:
 - i) to establish whether the aircraft is classed as an EASA or Annex II type. In the former case the aircraft will be eligible for an EASA C of A and the requirements/conditions that apply. In the latter case the aircraft will be eligible for either a UK C of A or a Permit to Fly and the requirements/conditions that apply.

- ii) where such aircraft are of wooden construction, to consider carefully the condition of the structure and its history before applying for the issue of a C of A or Permit to Fly. The CAA will require information as to the type of constructions and glue used.

5 **Supplementary Information** CAA Civil Aircraft Airworthiness Information and Procedures Leaflet 51-10, Inspection of Wooden Structures.

Leaflet 51-30 Timber Conversion – Spruce

1 Introduction

- 1.1 A good basic knowledge combined with many years' experience in the handling of timber is essential for the accurate assessment of the characteristics and defects which make it either suitable or unsuitable for aircraft parts.
- 1.2 This Leaflet is not intended to give guidance on how to select timber; it outlines the CAA's recommended method of converting it into aircraft parts and mentions common defects which may be encountered during conversion.

2 Seasoning

- 2.1 Timber which has been cut from selected trees is stacked, prior to shipment, for approximately 60 days. During this time, the timber loses much of its free moisture and it is in this condition that it should be transported.
- 2.2 Timber is usually seasoned in air-drying sheds for periods ranging from one to three years, or longer. If it is required for immediate use, it may be artificially seasoned (i.e. kiln-dried).
- 2.3 The process of seasoning reduces the moisture content of timber to a point where it is in equilibrium with the surrounding atmosphere and enables protective treatments to be applied more effectively.

3 Characteristics

After the timber has been properly seasoned, samples should be cut and tested to determine its suitability for use on aircraft. Before taking the samples from a plank of timber, approximately 6 inches should be cut from the end and discarded as this piece may be drier than the remainder.

3.1 Moisture-Content

The moisture-content of the sample should be determined by weighing it and then drying it in an oven at a temperature of 100° to 105°C (212° to 221°F) until two successive weighings yield the same result. Care should be taken to ensure that when the sample is split up, no material is lost and that the weighing is done promptly so as to avoid false results. The moisture-content should be calculated from the following formula:

$$\frac{W_1 - W_2}{W_2} \times 100$$

where W_1 = the weight of the sample prior to drying
and W_2 = the weight of the sample after drying.

3.2 A quicker method of determining the moisture-content of timber is by the use of the Marconi Moisture Meter. This instrument will record the moisture-content in a few seconds, whereas the method of weighing, drying and calculating takes much longer. The meter should however, be checked periodically to ascertain that it remains accurate. For general guidance, the correct moisture-content should be 15% with a tolerance of $\pm 2\%$.

3.3 **Density**

The density should be determined by weighing and measuring the volume of a sample cut from the plank. A practical method of calculating the density in imperial units is to cut the sample 96 mm (3.8 inches) long, by 25 mm (1 inch) square, and determine its weight in grammes. The figure for the weight of the sample in grammes is equal to the figure for the density in pounds per cubic foot. The weight of spruce generally varies between 320 kg and 577 kg per cubic metre (20 lb. and 36 lb. per cubic foot). For Grade A spruce, the density should not be less than 384.45 kg per cubic metre (24 lb. per cubic foot) when the moisture-content is 15%.

3.4 **Brittleness**

3.4.1 A notched test piece, the sides of which are cut radially and tangentially, of the dimensions 133 mm (5¼ inches) long by 22 mm (7/8 inch) square, should be broken in an impact test machine of the Izod type, the blow being applied tangentially; the test piece should absorb not less than 6.78 Joules (5 foot-pounds). Care should be taken that the blow is applied in the right direction, for if broken the opposite way a false reading will be obtained. A tolerance of 0.68 Joules (0.5 foot-pounds) is generally allowed, provided the fracture shows a satisfactory amount of fibre.

3.4.2 The weight-dropping machine provides an alternative method of testing timber for brittleness. A plain test piece, 305 mm (12 inches) long by 25 mm (1 inch) square, should be cut radially and tangentially, and parallel to the grain. When placed in the testing machine, the test piece should withstand one blow of 17.63 Joules (13 foot-pounds) without showing signs of tension failure on the vertical sides. Where doubt exists, a further blow of 8.81 Joules (6.5 foot-pounds) may be applied and there should be no sign of failure. The opening out of a few fibres should not be interpreted as a failure.

3.5 **Splitting Test**

The object of this test is to determine the inclination of the grain. The sample should be split with a very blunt chisel so that the wood will be split and not cut. The split surfaces give the true direction of the grain. The split should be made some distance from the edge of the sample, otherwise a misleading result may be obtained.

3.6 **Rate of Growth**

The number of annular rings per 25 mm (1 inch) varies to some extent. Timber with a rate of growth of less than 6 rings per 25 mm (1 inch) should be rejected.

3.7 **Recording of Tests**

The results of the above-mentioned tests should be recorded and related to the plank of timber to which they refer. The actual test pieces should also be kept for a period of not less than 2 years.

4 Conversion

After the bulk timber has been tested and graded, it may be converted into structural members for use on aircraft. This conversion should be done with every possible care, for much depends on the way in which timber is sawn.

4.1 Rift-Sawing

The process of cutting timber along the radius of the annular rings is known as rift-sawing. An illustration of this is given in Figure 1. Rift-sawing and near-quarter-sawing are very much the same.

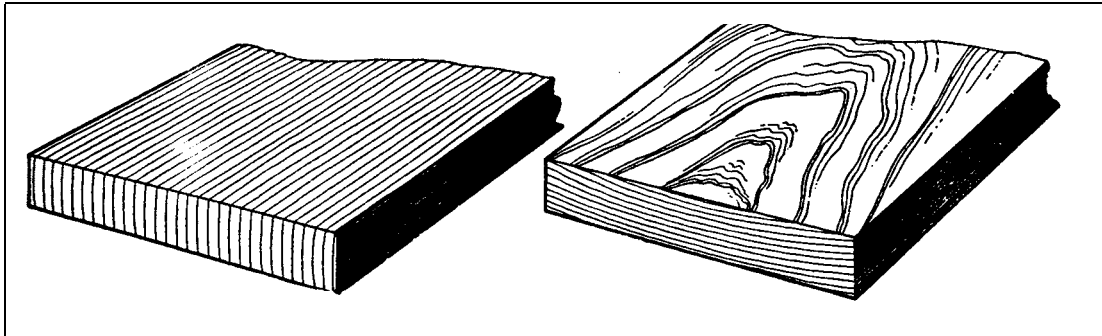

Figure 1

Figure 2

4.2 Tangential-Sawing

The process of cutting at a tangent to the annular rings is known as tangential-sawing. An illustration of this is given in Figure 2. Tangential-sawing (slashing) produces what is commonly known as a 'flower-face'.

4.3 General

4.3.1 Before a piece of bulk timber is converted, the end section of the plank should be noted, particularly the direction of the annular rings. It will be seen from this whether the plank is tangential-sawn, rift-sawn or quarter-sawn.

4.3.2 The actual method of converting timber is best described by the use of an example as follows. Assuming that spar members of a rough finished size of 102 mm (4 inches) by 51 mm (2 inches) are required and a 102 mm (4 inch) rift-sawn plank of timber is available, it should be cut tangentially to give a size of 102 mm (4 inches) by 102 mm (4 inches), after which a radial cut will give rift-sawn pieces 102 mm (4 inches) by 51 mm (2 inches) (allowance should, of course, be made for the saw-cut). The main advantage of rift-sawn timber is that it shrinks chiefly in one direction only, and does not warp very much.

5 Defects

After timber has been converted it should be examined for defects. Some of the more common defects are outlined in the following paragraphs.

5.1 Dote Disease

This is the worst of all defects and does much damage to the wood. It is an inherent disease which only occurs at the base of the living tree. When the tree is felled it is cut at a point ten feet or more above the ground as a precaution against the possibility of dote. Converted pieces of timber should be examined not only on the sides but also

on the ends; dote will be recognised by the presence of brownish yellow patches, somewhat similar to thin mineral oil spots. Dote is contagious and any infected wood should be burnt.

5.2 **Decay or Rot**

A defect similar to dote disease can develop after a tree has been felled if the timber is exposed to excessive soaking and partial drying. Dry-rot fungus requires a certain amount of moisture to thrive on but once the disease is established it thrives on the moisture already in the wood. The decayed wood is brown in colour and appears as though it had been charred; the timber is rendered soft and dry, and will flake off easily.

5.3 **Incorrect Grain Inclination**

The limit of grain inclination for spruce is 1 in 15 for grade A, and 1 in 12 for grade B. The inclination should be checked to ensure that the above limits are not exceeded. The most usual method of determining the inclination of the grain is by examining the flower-face of the timber to find the resin ducts. It will readily be seen whether they are straight or inclined. If the inclination exceeds the limits specified, the timber should be classified in a lower grade.

5.4 **Heart-Shake**

This defect usually follows the course of a sap duct longitudinally, and is usually visible on the tangential surface. The use of a small size feeler gauge will assist in finding the depth of the shake. The defect should be cut out of the timber.

5.5 **Ring-Shake**

This defect is indicated by a parting of the annular rings. Ring-shakes are usually caused by frost, particularly after a heavy rainfall. The defect should also be cut out of the timber.

5.6 **Compression-Shake**

This defect appears on a cross-section and usually takes the form of a thin wavy line. Compression-shakes are most dangerous as they are a partial fracture of the timber and any future loads may cause the fracture to be completed.

5.7 **Knots**

There are several kinds of knots which may be encountered when examining converted timber; these are the dead-knot, the bud-knot and the pin-knot. The presence of any of these knots can have a detrimental effect. Generally they should not be more than a quarter of an inch in diameter but no hard and fast rules can be specified; each case must be decided on its merits. Timber with 'clusters' of pin-knots in it should be rejected.

5.8 **Pitch Holes**

There are two kinds of pitch holes, one being the horizontal type which usually appears at the base of a knot, and the other the vertical type which is sometimes referred to as a gum pocket. Gum pockets may either be 'alive' (the gum-seam has not dried out) or 'dead', and in the case of the latter, the timber should be rejected. Tests on 'live' gum pockets have shown that the timber in the region of the gum pocket usually gives a better result than the remainder of the timber.

5.9 **Blue Stain**

This defect only occurs in sapwood which should not be used in aircraft parts.

Leaflet 51-40 Synthetic Resin Adhesives

1 Introduction

This Leaflet provides guidance and advice on the gluing of wooden structures and on the adhesives which can be used for this purpose.

- 1.1 Synthetic resin adhesives are used extensively for joints in wooden structures to avoid the localised stresses and strains which may be set up by the use of mechanical methods of attachment; the strength of such structures depends largely on the effectiveness of the glued joints and cannot be verified by means other than the destruction of the joints. Acceptance has therefore, to be governed by adequate inspection at various stages throughout the gluing process and by assessment of the results obtained from representative test pieces (see paragraph 9).
- 1.2 Synthetic resin adhesives used for gluing aircraft structural assemblies must comply with the requirements prescribed in an acceptable Specification, usually British Standard BS EN 301: 2006, for Weather and Boil Proof (WBP) or Moisture Resistant (MR) adhesives.
- 1.3 Information on the inspection of glued joints for evidence of deterioration under service conditions is given in Leaflet 51-10.
- 1.4 The terminology used in this Leaflet is that given in BS EN 301: 2006, entitled 'Adhesives, Phenolic and Aminoplastic, for Load Bearing Timber Structures: Classification and Performance Requirements'. For those not familiar with the terminology, a glossary of terms not explained in the text is given in paragraph 13.

2 General

Synthetic resin adhesives (see paragraph 13.12) usually consist of two separate parts, i.e. the resin and the hardener. The resin develops its adhesive properties only as a result of a chemical reaction between it and the hardener, and will not harden without it. With some adhesives, an inert filler may be added to increase viscosity and to improve gap-filling properties.

3 Preparation of Adhesives

Synthetic resins (see paragraph 13.11) can be obtained in either liquid or powder form. In general, powder resins have the longer storage life, since they are less susceptible to deterioration which can result from high ambient temperatures.

3.1 Powder Resins

Powder resins should be mixed with water in accordance with the manufacturer's instructions before they can be used in conjunction with a hardener and to obtain satisfactory results it is essential that they should be properly mixed. Once mixed, the resin should not be diluted unless this is specifically permitted by the manufacturer.

3.2 Liquid Resins

When resins are supplied in liquid form, they are ready for immediate use in conjunction with the hardener. Liquid resin should not be diluted unless this is permitted by the manufacturer.

3.3 **Hardeners**

When mixing the hardener (paragraph 13.7) with the resin, the proportions should be in accordance with the manufacturer's instructions. Hardeners should not be permitted to come into contact with the resin except when the adhesive is mixed just prior to use, or, as is necessary with some adhesives, when the joint is assembled by coating one face with resin and the other with hardener. When the latter method is employed, the surface to which each is applied should be in accordance with drawing requirements (see paragraph 6).

3.4 **Mixed Adhesives**

In many instances, manufacturers specify a definite period of time which must elapse between the mixing and the application of the adhesive and during this period the adhesive should be kept covered to prevent contamination.

3.5 **Utensils**

The utensils used for hardener should not subsequently be used for resin, and vice versa. These utensils and those used for the mixed adhesive should be acid-proof and should be kept scrupulously clean. After use and before the adhesive has had time to set, they should be cleaned with warm water containing 5% sodium carbonate (washing soda).

4 **Preparation of Surfaces**

4.1 **Plywood Surfaces**

All areas of plywood surfaces to be glued should first be 'sanded' in order to remove surface glazing and loose fibres. Sanding should be done lightly and uniformly either in the direction of the grain or diagonally across it, using a medium grade of glasspaper; local scratching or roughening, use of too coarse a paper and undue pressure, should be avoided. The sanding should not be excessive otherwise the fit of the joint may be affected.

4.2 **Timber Surfaces**

Timber surfaces should be suitably roughened so as to form a firm key for the adhesive and a medium grade of glasspaper or a wood scraper is suitable for this purpose. To form a strong efficient joint, it is essential that the mating surfaces should be a good fit. This is particularly important in the case of blind joints, the members of which may be chalked on their gluing surfaces before being assembled dry as a check on the fit; the chalk should be completely removed before application of the adhesive.

4.3 **Moisture Content**

It is important that the parts to be joined should have approximately the same moisture content, since variations may cause stresses to be set up as a result of swelling or shrinkage and thus lead to the failure of the joint. The moisture content should, additionally, be within the specification limits for the particular timber. A safe range would be 8 to 16%, but with resorcinols this could be extended to 20% from a gluing viewpoint; however, this would not be satisfactory for aircraft components as joints would be likely to shrink after manufacture.

4.3.1 The moisture content of timber can be determined by taking a sample of the timber to be glued, weighing it, and then drying it in an oven at a temperature of 100° to 105°C (212° to 221°F) until two successive weighings yield the same result. The moisture content can be determined by the formula:

$$\frac{W_1 - W_2}{W_2} \times 100$$

where W_1 = the weight of the sample prior to drying

and W_2 = the weight of the sample after drying.

- 4.3.2 A method of determining the approximate moisture content is by the use of an electrical meter working on either the resistance or the capacitance principle. When this instrument is used, its accuracy should be checked periodically against a sample, the moisture content of which is determined by the weighing method described in paragraph 4.3.1.

4.4 **General**

The surfaces to be joined should be clean and free from grease, oil, wax, crayon, paint and varnish; it is advisable not to handle the joint faces once they have been prepared. Where old timber is to be re-used, all traces of the previous adhesive should be removed and the timber beneath cleaned; local staining of the wood by previous hardener or casein cement may be disregarded. Where any painting operations are to be carried out, all surfaces which are to be glued should be adequately masked.

5 **Conditions for Gluing**

Synthetic resin adhesives are very sensitive to variations in temperature and the usable (pot) life of the adhesive, choice and proportion of hardener and clamping times, all depend largely on the ambient temperature at the time of gluing; it is, therefore, important to ensure that the manufacturer's instructions regarding these factors are followed.

- 5.1 The timber to be glued should be allowed sufficient time to attain the temperature of the room in which the gluing is to take place; it should not be overheated or raised too quickly from a low temperature, since this affects the surfaces of the timber and reduces the efficiency of most synthetic resin adhesives. It is important, therefore, that timber should be kept clear of radiators and other sources of heat prior to gluing.

6 **Application of Adhesive**

With certain exceptions, adhesives are used in the mixed form and the recommendations given in this paragraph apply only to the use of such adhesives.

- 6.1 It is generally desirable to apply adhesive to both surfaces of a joint. This applies particularly where plywood is to be glued to a fairly robust member, where the glue line (see paragraph 13.6) is likely to be variable or when it is not possible to apply uniform pressure to the joint after gluing.
- 6.2 Ordinary glue spreaders are satisfactory for the application of synthetic resin adhesives, but those having slightly grooved rubber rollers give the best results. Brushes may also be used provided they are perfectly clean.
- 6.3 The amount of adhesive required depends largely on the type of timber and the accuracy of machining; dense timbers require less adhesive than soft or porous types. Side-grained surfaces may be satisfactorily glued with thin spreads, and while end-grain joints have virtually no structural value, generous spreads may be applied for gap

filling and sealing purposes. The general rule is that the adhesive should completely cover the surfaces to be glued and should be tacky when pressure is applied to the joint.

- 6.4 Difficult gluing conditions may sometimes occur when a soft timber is to be glued to one which is much denser, because the adhesive tends to flow into the more porous timber. In such instances, unless otherwise specified by the manufacturer of the adhesive, pre-coating and partial drying of the softer surface, prior to normal spreading, is recommended.

7 Assembly

Care should be taken before the adhesive is applied to ensure that the surfaces make good contact and that the joint will be correctly positioned, since once contact is made after the adhesive is applied, the joint will be below strength if further movement is necessary. The interval between the application of the adhesive and assembly of the joint under pressure should, unless otherwise permitted, be kept as short as possible. Pressure should be applied quickly and should be even. All devices used to bring the glued surfaces together should be checked (this applies particularly to clamps) to ensure that the pressure is uniformly applied over the entire area; uneven pressure may cause uneven contact and a gaping joint.

NOTE: Some adhesives contain solvents which should be allowed to evaporate before the joint is made. If this is not done, bubbles may be created and a weakness caused. For adhesives of this type the manufacturer will specify a time interval which should elapse before the joint is closed.

- 7.1 High clamping pressures are neither essential nor desirable provided that good contact between surfaces being joined is obtained. For parts which are flat and unstressed it is not always necessary to maintain the pressure until the full joint strength is developed, but for work which is shaped by pressure, longer times may be required to guard against opening stresses. The tightness of clamps should be checked approximately 10 minutes after assembly.
- 7.2 If the parts are thin and the pressure is uniformly distributed, only a slight pressure is required and small pins or screws will generally provide this; care should be taken not to pump the adhesive out of the joint when hammering pins through closing strips.
- 7.3 When pressure is applied, a small even quantity of glue should be expressed from the joint and this should be wiped off before it dries. The pressure should be maintained and the joint should not be disturbed during the full setting time; this is important as the adhesive will not re-unite if disturbed before it is fully set.
- 7.4 When large 'glue-face' areas are to be joined, e.g. when joining two ply surfaces, the drawing usually specifies the drilling of small vent holes at regular intervals to prevent air being trapped between the two surfaces. After the joint has been made, these holes should be checked to ensure that adhesive has exuded from them.

8 Setting Times and Temperatures

The setting time depends on the temperature at which the jointing operation is carried out; an increase in temperature results in a decrease in the setting time. Conversely, a decrease in temperature causes a considerable increase in the setting time and with some adhesives a temperature below 15°C (60°F) is not recommended. It is, therefore, generally advantageous to apply heat during pressing whenever possible so as to effect reasonably quick and strong adhesion. Heat may be applied by means

of an electrically or steam heated platen such as would be used for special presswork. Local warmth may be applied with electrically heated blankets, electric fires, a battery of electric bulbs, or drying kilns. The temperature may generally be raised to approximately 80°C (176°F) for very rapid setting; intense surface heating should be avoided as this may scorch the timber and cause the glue to bubble, the latter resulting in the production of a very weak joint. It must be remembered that it is the temperature of the glue line which determines cure rate and not the surface or ambient temperature. The warming of a cold assembly may cause the exuded glue to harden quickly, giving a false impression that the complete joint has cured (see also paragraph 5.1).

- 8.1 Full joint strength and resistance to moisture will only develop after conditioning for a period of at least 2 days, depending on the temperature and the type of hardener used. However, when repairs are made on aircraft, the joint should be of sufficient strength after one day. When it is necessary to ensure maximum resistance to moisture it is generally recommended that the assembled structures should be kept at room temperature of 21° to 24°C (70° to 75°F) for 2 to 3 weeks so that complete chemical reaction can take place.
- 8.2 Further assembly work can be carried out immediately the clamps have been removed provided the joint is not subjected to additional stress, otherwise the conditioning period recommended by the manufacturer is necessary. The degree of setting of the adhesive which has squeezed from the glue line is not necessarily an indication of the strength of the joint, and precautions should be taken to ensure that the joints are handled with due care until they have attained full strength.
- 8.3 After the joint has been conditioned and all work completed, all unprotected parts should be treated in accordance with drawing requirements.

9 Testing

Frequent tests should be made to ensure that joining techniques are satisfactory. Wherever possible, tests should be carried out on off-cuts of actual components from each batch. Where off-cuts are not available tests should be carried out on representative test pieces glued up with each batch of mixed adhesive. In addition, the glue strength of component rejected for faults other than gluing should be checked periodically.

9.1 Test Samples

The test samples should be cut from the timber used for the component and should not be less than 50 mm (2 in) long and 25 mm (1 in) wide with one member overhanging the other by 12 to 18 mm (½ to ¾ in). The glued test sample should, when conditioned, be put in a vice and the joint should be broken by leverage exerted on the overhanging member. The fractured glue faces should show at least 75% of wood fibres, evenly distributed over the fractured glue surfaces. A typical broken test piece is shown in Figure 1.

9.2 Wet Tests

When specified, wet tests should be made for the purpose of testing the efficiency of the adhesive after immersing the test samples in water at different temperatures and for different times. Such tests are prescribed in British Standard BS EN 301: 2006, but the results are only valid if BS EN 301: 2006 test pieces are used. However, testing joints, in a manner similar to that outlined in paragraph 9.1, after immersion in cold water (15° to 25°C (60° to 77°F)) for 24 hours, will give a good

indication of whether they are cured. Such tests should only be carried out on joints which have been conditioned for 2 to 3 weeks as in paragraph 8.1.

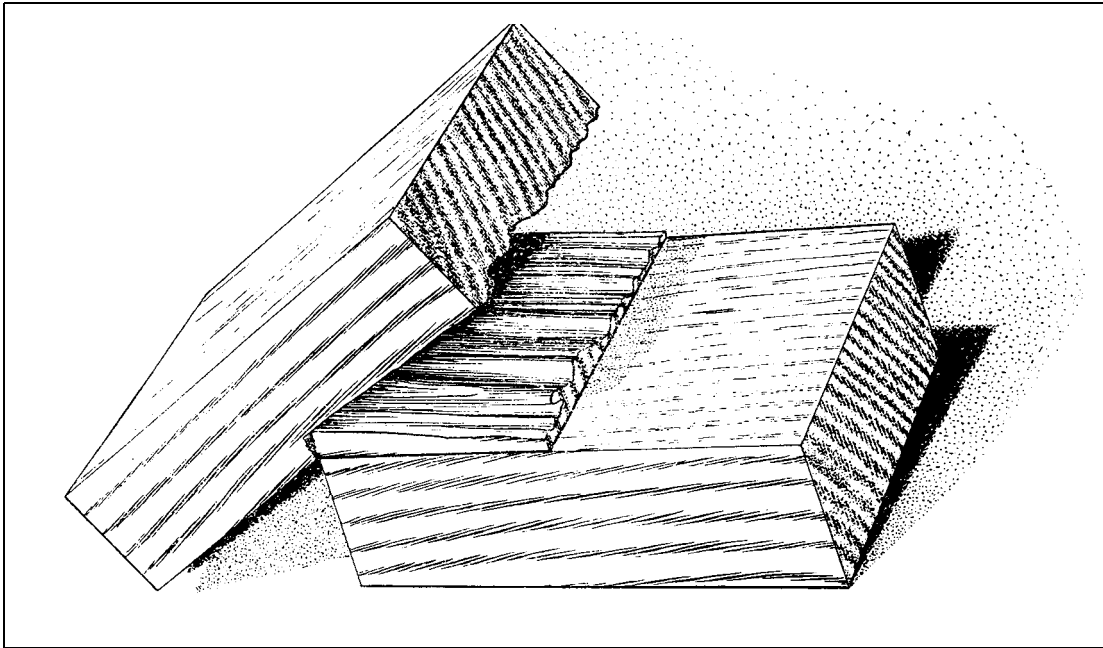

Figure 1 Broken Test Piece

10 Failure of Glued Joints

Glued joints are designed to provide their maximum strength under shear loading. If a glued joint is known to have failed in tension it is difficult to assess the quality of the joint, as these joints may often show an apparent lack of adhesion. Tension failures often appear to strip the glue from one surface leaving the bare wood; in such cases, the glue should be examined with a magnifying glass, which should reveal a fine layer of wood fibres on the glued surface, the presence of which will indicate that the joint itself was not at fault. If examination of the glue under magnification does not reveal any wood fibres but shows an imprint of the wood grain, this could be the result of either pre-cure of the glue prior to the application of pressure during the manufacture of the joint, or the use of surface-hardened timber. This latter condition is particularly common with plywood and with other timbers which have been worked by high speed machinery and have not been correctly prepared in accordance with paragraph 4.1. If the glue exhibits an irregular appearance with star-shaped patterns, this may be an indication that the pot-life of the glue had expired before the joint was made or that pressure had been incorrectly applied or maintained. In all such instances other joints in the aircraft known to have been made at the same time should be considered to be suspect.

11 Aircraft Repairs

Where repairs are to be carried out on old aircraft in which the wooden structure is joined with a casein glue, all traces of the casein should be removed from the joint, since this material is alkaline and is liable to affect the setting of a synthetic resin adhesive; local staining of the wood by the casein can however be disregarded. Where urea formaldehyde (UF) glues are to be used, the surface should be wiped with a solution of 10% w/w acetic acid in water, and allowed to dry before applying.

NOTE: This process must only be used with urea formaldehyde (UF) glues. If used prior to the application of, for example, resorcinol formaldehyde (RF) glues, the joint strength could be seriously impaired.

12 Storage

Apart from the very limited pot-life of the mixed adhesive, the resin itself will not keep indefinitely, even under ideal storage conditions. Under no circumstances should the shelf life specified by the manufacturer be exceeded. Furthermore, resins in powder form which show signs of caking or corrosion of the container and liquid resins which show signs of 'gelling' or have become excessively viscous, should be rejected even if the shelf life has not been exceeded. During storage, a temperature of 21°C (70°F) should not be exceeded.

13 Glossary of Terms

For the benefit of those not familiar with the terms used in relation to synthetic resin adhesives and their application, a glossary is given below.

- 13.1 **Cold Setting Adhesive.** An adhesive which sets and hardens satisfactorily at ordinary room temperature, i.e. 10° to 32°C (50° to 86°F), within a reasonable period.
- 13.2 **Close Contact Adhesive.** A non-gap-filling adhesive suitable for use only in those joints where the surfaces to be joined can be brought into close contact by means of adequate pressure and where glue lines (see paragraph 13.6) exceeding 0.125 mm (0.005 in) in thickness can be avoided with certainty.
- 13.3 **Closed Assembly Time.** The time elapsing between the assembly of the joints and the application of pressure.
- 13.4 **Double Spread.** The spread of adhesive equally divided between the two surfaces to be joined.
- 13.5 **Gap Filling Adhesive.** An adhesive suitable for use in those joints where the surfaces to be joined may or may not be in close or continuous contact, owing either to the impossibility of applying adequate pressure or to slight inaccuracies of machining. Unless otherwise stated by the manufacturer, such adhesives are not suitable for use where the glue line (see paragraph 13.6) exceeds 1.25 mm (0.05 in) in thickness.
- 13.6 **Glue Line.** The resultant layer of adhesive effecting union between any two adjacent wood layers in the assembly.
- 13.7 **Hardener.** A material used to promote the setting of the glue. It may be supplied separately in either liquid or powder form, or it may have been incorporated with the resin by the manufacturer. It is an essential part of the adhesive, the properties of which depend upon using the resin and hardener as directed.
- 13.8 **Open Assembly Time.** The time elapsing between the application of the adhesive and the assembly of the joint components.
- 13.9 **Single Spread.** The spread of adhesive to one surface only.
- 13.10 **Spread of Adhesive.** The amount of adhesive applied in order to join two surfaces, usually expressed in g/m² or lb/100 ft².
- 13.11 **Synthetic Resin.** A synthetic resin (phenolic) is derived from the reaction of a phenol with an aldehyde. A synthetic resin (aminoplastic) is derived from the reaction of urea, thiourea, melamine or allied compounds with formaldehyde.

- 13.12 **Synthetic Resin Adhesive.** A composition substantially consisting of a synthetic resin of either the phenolic or aminoplastic type, but including any hardening agent or modifier which may have been added by the manufacturer or which may be required to be added before use, according to manufacturer's instructions.

Leaflet 51-50 Inspection of Metal Aircraft Structures

1 Introduction

This Leaflet gives general guidance on the inspection of those parts of a metal aircraft structure which, because of their remoteness, complexity or boxed-in design, are not readily accessible for routine maintenance or require special attention in the light of operational experience.

2 General

Deterioration may arise from various causes and can affect various parts of the structure according to the design of the aircraft and the uses to which it is put. Therefore, this Leaflet should be read in conjunction with the appropriate manufacturer's publications, i.e. OEM Standard Practices and the Maintenance Programme for the aircraft concerned.

- 2.1 Although considerable guidance may be given in the appropriate publications as to suitable opportunities for inspecting normally inaccessible structures (e.g. when a wing tip is removed permitting access to the adjacent wing structure) experience should indicate to the operator further opportunities for such inspections which can be included in the Maintenance Programme. Apart from the airworthiness aspects, these combined inspections could often be to the operator's advantage, since they would obviate the need for future dismantling.
- 2.2 Where access has been gained to a part of the structure which is normally inaccessible, advantage should be taken of this dismantling to inspect all parts of systems thus exposed.

3 Corrosion

The presence of corrosion in aircraft structures is liable to result in conditions which may lead to catastrophic failures. It is therefore essential that any corrosive attack is detected and rectified in the earliest stages of its development.

- 3.1 In general, no corrosive attack on an aircraft structure will occur without the presence of water in some form. However, a fact less well appreciated is that, in a wide variety of ambient conditions, condensation will form on various parts of the structure and this is one of the main causes of corrosion.
 - 3.1.1 By the nature of their operation, aircraft are exposed to frequent changes of atmospheric temperature and pressure and to varying conditions of relative humidity; therefore, all parts of the structure are subject to some form of condensation. The resultant water takes into solution a number of corrosive agents from the atmosphere or from spillages (which convert the water into a weak acid) and will corrode most metal surfaces where the protective treatment has been damaged or is inadequate. Cases of serious corrosion have been found in both closed and exposed parts of structures of aircraft operated under a wide variety of conditions.
 - 3.1.2 Corrosion can be intergranular; therefore, the removal of the surface products of corrosion followed by reprotection is not necessarily effective. Once the surface is penetrated the reduction in strength due to corrosion is disproportionate to the reduction in thickness of the metal.

3.2 Air-conditioned Compartments

In air-conditioned compartments, condensation will occur where the warm inside air impinges on the colder areas of the structure such as the inner surfaces of a pressure cabin skin. Considerable quantities of water will tend to collect and run down the inside of the cabin walls.

3.2.1 To avoid corrosion it is important to ensure that the water is unimpeded in its flow down to the bilge area. The structure and all drain holes through stringers, etc., should be kept clean and free from obstructions and drainage ducts should be checked for clearance and damage. A check should be made to ensure that water or moisture is not being trapped by the thermal acoustic lining or any other form of upholstery.

3.2.2 Water collecting in the lower parts of the structure and in the bilge area can be highly contaminated. It will not only contain the corrosive agents mentioned in paragraph 3.1.1, but also other impurities due to fumes, spillages, etc., emanating from the galley, toilets and smoking compartments, thus intensifying the corrosive nature of the water. At specified periods these parts of the structure should be thoroughly cleaned and carefully inspected for signs of corrosion and for deterioration of the protective treatment.

3.2.3 Thermal acoustic linings usually have a waterproof covering on the side adjacent to the structure, or the thermal acoustic material may be completely enveloped in a waterproof covering. Any damage to the waterproof covering may lead to considerable absorption of water into the lining, setting up corrosion between the damaged lining and the surrounding structure.

NOTE: Water soakage of upholstery and especially of thermal acoustic linings can also result in an appreciable increase in aircraft weight. Instances have also occurred where saturated compartment linings have caused electrical failures.

3.3 Structural Parts Susceptible to Corrosion

The manufacturer's publications give general guidance on the inspection of those parts of the structure which are most likely to be attacked by corrosion. Nevertheless, it should be noted that, in the light of operational experience, other parts of the structure may require special attention. Engineers should be on the alert for any signs of corrosion in parts of the structure not specifically mentioned in the manufacturer's publications or instructions.

3.3.1 In 'blind' or boxed-in structures where accessibility is difficult and where cleaning and maintenance are awkward, dirt and dust tend to collect and lodge in various parts. This dirt and dust acts as a 'wick' for moisture which, in the course of time, will work through any inadequate protective treatment and penetrate to the metal to act as an electrolyte. Even on new aircraft the problem is still present in some boxed-in or intricate structures.

NOTE: Protective treatments with a rough surface finish, such as primer paints, tend to hold dust and dirt and cleaning is rendered more difficult because of this tendency of dust and dirt to adhere to such surfaces. Hard gloss finishes, such as epoxy resin paints, will provide a more effective and lasting protection.

3.3.2 Completely boxed-in structures should be adequately vented to prevent stagnation of the internal air. It is important to ensure that vents and drain holes are clear, are of the correct size and are unobstructed by ice in freezing conditions on the ground.

3.3.3 Honeycomb structures, especially those in components of small cross-sectional area (e.g. wing flaps), are often prone to the collection of water if careful attention has not been given to the sealing around attachment screw holes and at skin joints to prevent ingress of moisture. Cases are known where the trapped water in the structure has

frozen and caused distortion of the outer skin of the component due to internal expansion.

- 3.3.4 Fuselage keel areas, structures concealed by upholstery (see e.g. paragraph 3.2) and the double skin of freight bay floors, are typical areas liable to corrosion. Special attention should be given to all faying surfaces in these areas and particularly the faying surfaces of stringers to skin panels and skin lap joints. In general, visual inspection supplemented by radiological methods of examination is a satisfactory way of detecting corrosion, provided it is expertly carried out and proper correlation between the findings of each method is maintained. In some instances, however, normal methods of visual inspection supplemented by radiological examination have not proved satisfactory and dismantling of parts of the structure may be required to verify the condition of the faying surfaces.
- 3.3.5 Structures manufactured from light gauge materials which are spot-welded together, such as the faying surfaces of stringers mentioned in the previous paragraph, are liable to serious and rapid corrosion as this method of attachment precludes the normal anti-corrosive treatments (e.g. jointing compound) at the faying surfaces. Cases of serious corrosion have also been found in similar structures riveted together where the jointing compound has been found to be inadequate.
- 3.3.6 In some instances, where stringers are of top-hat section and are bonded to the panel by a thermosetting adhesive, corrosion has been known to affect the stringers, the panel and the bonding medium; such stringers are often sealed at their ends to prevent the ingress of moisture, etc. Where adhesive is used to attach a doubler to a skin, corrosion can occur between the surfaces and will eventually be indicated by a quilted appearance.

3.4 **Exhaust Gases**

Structural parts which are exposed to exhaust gases are prone to corrosion due to the sulphur content of exhaust gases and jet efflux. Although this problem can be reduced by regular and thorough cleaning, particular attention should be given to the condition of the protective treatment of these structures.

3.5 **Stress Corrosion**

- 3.5.1 Stress corrosion in aluminium tends to occur mainly in the high-strength alloys and is due to locked-in stresses resulting from some aspects of heat treatment or inappropriate assembly practices. Stress corrosion takes the form of cracking which, in conjunction with other corrosion, can lead to the sudden and complete failure of structural parts.
- 3.5.2 Stress corrosion cracking in titanium depends on the composition of the alloy, its processing and its notch sensitivity. Some titanium alloys may develop rapid crack growth if contaminated with a saline solution after a crack has been initiated.

3.6 **Fretting**

Fatigue failures often result from fretting at structural bolted joints. Fretting is revealed by black or greyish brown powder or paste around the periphery of the faying surfaces and may result in the formation of cracks at the outer edge of the fretted area; these cracks may develop across the component and will not necessarily pass through the bolt hole. Dismantling of suspect parts is usually necessary and an inspection by penetrant dye, magnifying lens, eddy current or ultrasonic (surface wave) methods should be carried out.

4 Spillage

Spillage or system leaks of extraneous fluids which may penetrate the structure during maintenance, repair or operation of the aircraft, should be carefully traced and thoroughly cleaned out. Where required, any protective treatment should be restored. Fluids such as ester-based engine oils, glycol defrosting fluids, etc., will damage most protective treatments not intended to be in contact with them. Accidental spillage of refreshments such as mineral waters, coffee, etc., have a particularly deleterious effect on floor structures.

- 4.1 With an aircraft in operation there are areas where spillages invariably occur, such as in galleys and toilet compartments. Here, careful cleaning and the maintenance of any special floor protection is important. The floor structures around and below these compartments should receive special attention to ensure protection against seepage and corrosion. Where animals are carried, special precautions are essential because corrosion due to animal fluid can cause rapid deterioration of metals. The floor and sides of compartments in which animals are housed should be protected by suitable means against seepage and the structure below the floor should be carefully inspected for any signs of seepage or corrosion.

NOTE: Where animals are not housed in containers specially designed for air transport, unbroken impervious sheeting such as waterproof canvas or heavy polythene sheet, should be laid on the floor and fixed at the required height on the fuselage sides and bulkheads to prevent any seepage into the aircraft structure. A form of matting, preferably made of absorbent material, should be laid on the sheeting to prevent damage due to animal movements.

- 4.2 Battery compartments should be examined for any signs of acid corrosion. Compartment vents should be clean and undamaged and the anti-sulphuric protective treatment should be carefully maintained. Special attention should be given to the structure in the immediate vicinity of the battery for any signs of corrosion caused by acid spillage or a damaged battery. It should be noted that heavy concentrations of battery fumes, resulting from faulty compartment venting or a runaway battery, may also lead to corrosion in the surrounding structure.

NOTE: If there is any indication of corrosion, the parts affected should be cleaned with a solution of water and washing soda, then rinsed with fresh water and dried out. After 24 hours a re-check should be made for further signs of corrosion and, if satisfactory, the protective treatment should be restored.

- 4.3 The spillage of mercury in an aircraft can have devastating effects on any aluminium alloy skin or structure with which it comes into contact.

5 Corrosive Effects of Agricultural Chemicals

On aircraft used for crop spraying or dusting, considerable attention and special care should be given to the inspection of the structure owing to the highly corrosive nature of certain of the chemicals used for these purposes. The corrosive effect of some of the chemicals used for agricultural purposes may not always be fully known. Some chemicals which were considered to be harmless to aircraft materials, have proved, in the course of time, to be corrosive.

- 5.1 Thorough cleaning of the whole aircraft structure after agricultural spraying operations is very important. Unless otherwise specified by the manufacturer of the chemical, the aircraft should be thoroughly washed, both internally and externally, with copious supplies of clean water. Engine intakes and exhausts and other openings, should be blanked during the washing to prevent the ingress of water. After washing, it is

essential to check that no pockets of chemicals or water remain trapped in the structure, that all drains are clear and that all covers or devices used to prevent the ingress of chemicals are properly refitted.

- 5.2 A check should be made to ensure that the spray equipment tanks, pipes, pumps, etc., are leak-proof and that spray booms or spray nozzles are in their correct positions.
- 5.3 When filling up with chemical spray fluids care is necessary to avoid spillage. Where there is no provision to prevent spilled fluid finding its way into the structure, it is essential to avoid over-filling and the chance of accidental spillage can be reduced by using the proper filling equipment. If spillage does occur, it should be cleaned out immediately before it has penetrated into parts of the structure where cleaning would be more difficult.

6 Metal Fatigue

Metal fatigue can be briefly described as a weakening of a metal part under repeated applications of a cycle of stress. The weakening effect can be seriously accelerated by corrosion of the metal.

- 6.1 In the early stages, fatigue damage is difficult to detect by visual inspection and one of the methods of non-destructive examination outlined in the Part 1 Chapter F is usually specified; the method used depending on the type of structure and material concerned. In the majority of cases the presence of fatigue damage is revealed by the formation of a small hairline crack or cracks. Refer to paragraph 9 of this Leaflet.
- 6.2 Those parts of a structure where fatigue damage may occur are determined by design calculations and tests based on the expected operational use of the aircraft and substantiated by operational experience. At the periods specified in the appropriate publications, examination or renewal of the parts will be required. These periods are usually in terms of flying time or the number of landings, or from readings logged by load recording instruments. With certain materials and structures, renewal or sampling checks may be required on a calendar basis.
- 6.3 It is important to note that some parts of a structure may be liable to fatigue damage resulting from unforeseen causes, e.g. parts damaged or strained on assembly, invisible damage to the structure during assembly or maintenance work, or fretting (see Leaflet 51-110). When carrying out inspections it is important to check carefully for any signs of cracks emanating from points of stress concentration such as bolt-holes, rivets, sharp changes in section, notches, dents, sharp corners, etc. Fatigue damage can also be caused by pits and notches created by corrosion, although the corrosion may no longer be active. During the application of repeated stress cycles, crevices can be opened up and may eventually result in a fatigue failure.

NOTE: Poor fitting or malassembly can reduce fatigue life considerably. A spar has been known to fail under tests at a fraction of its normal life as a result of the stress concentration caused by a tool mark in a bolt-hole. Defects such as a burr on a bolt can cause a scratch inside the bolt-hole, which can seriously accelerate fatigue damage in a stressed member.

7 Cleanliness

It is important that aircraft should be thoroughly cleaned periodically and reference should be made to Leaflet 12-10.

- 7.1 Care should be taken not to damage protective treatments when using scrubbing brushes or scrapers and any cleaning fluids used should have been approved by the aircraft manufacturer. For final cleaning of a boxed-in type of structure an efficient vacuum cleaner, provided with rubber-protected adaptors to prevent damage, should be used. The use of air jets should be avoided as this may lead to dirt, the products of corrosion, or loose articles, being blown from one part of the structure to another.

8 Inspection

The structure should be maintained in a clean condition and a careful check should be made for any signs of dust, dirt or any extraneous matter, especially in the more remote or 'blind' parts of the structure. Loose articles such as rivets, metal particles, etc., trapped during manufacture or repair, may be found after the aircraft has been in operation for some considerable time. It is important to examine these loose articles to ensure that they did not result from damaged structure. It is generally easy to determine if a loose article has formed part of the structure by its condition, e.g. an unformed rivet could be considered as a loose article, but a rivet which had been formed would be indicative of a failure.

8.1 General

- 8.1.1 The structure should be examined for any signs of distortion or movement between its different parts at their attachment points, for loose or sheared fasteners (which may sometimes remain in position) and for signs of rubbing or wear in the vicinity of moving parts, flexible pipes, etc.

NOTES: 1) A wing structure has been known to have had a rib sheared at its spar attachments due to the accidental application of an excessive load, without any external evidence of damage, because the skin returned to its original contour after removal of the load.

2) For the inspection of bolted joints see Leaflet 51-110.

- 8.1.2 The protective treatment should be examined for condition. On light alloys a check should be made for any traces of corrosion, marked discolouration or a scaly, blistered or cracked appearance. If any of these conditions is apparent the protective treatment in the area concerned should be carefully removed and the bare metal examined for any traces of corrosion or cracks. If the metal is found satisfactory, the protective treatment should be restored.

NOTE: To assist in the protection of structures against corrosion some manufacturers may attach calcium chromate and/or strontium chromate sachets to the vulnerable parts of the structure. The presence of chromate in the sachets can be checked by feel during inspection. After handling these materials, the special precautions, e.g. hand washing, given in the manufacturer's manual, should be followed.

- 8.1.3 In most cases where corrosion is detected in its early stages, corrective treatment will permit the continued use of the part concerned. However, where the strength of the part may have been reduced beyond the design value, repair or replacement may be necessary. Where doubt exists regarding the permissible extent of corrosion, the manufacturer should be consulted.

- 8.1.4 The edges of faying surfaces should receive special attention (see also paragraph 3.3.4); careful probing of the joint edge with a pointed instrument may reveal the products of corrosion which are concealed by paint. In some instances slight undulations or bumps between the rivets or spot welds, or quilting in areas of

double skins due to pressure from the products of corrosion, will indicate an advanced state of deterioration. In some cases this condition can be seen by an examination of the external surface, but as previously mentioned in this Leaflet, dismantling of parts of the structure to verify the condition of the joints may be required.

- NOTES:**
- 1) To avoid damage to the structure, the probing of a joint with a pointed instrument should be carried out with discretion by an experienced person. Any damage done to the protective paint coating, however small, should be made good.
 - 2) Where dismantling of parts of the structure is required, reference should be made to Leaflet 51-90.

8.2 Visual Examination

Nearly all the inspection operations on aircraft structures are carried out visually and, because of the complexity of many structures, special visual aids are necessary to enable such inspections to be made. Visual aids vary from the familiar torch and mirrors to complex instruments based on optical principles and, provided the correct instrument is used, it is possible to examine almost any part of the structure.

NOTE: Airworthiness Requirements normally prescribe that adequate means shall be provided to permit the examination and maintenance of such parts of the aeroplane as require periodic inspection. Inspection standards can be found in OEM Documents and Aircraft Maintenance Planning Documents.

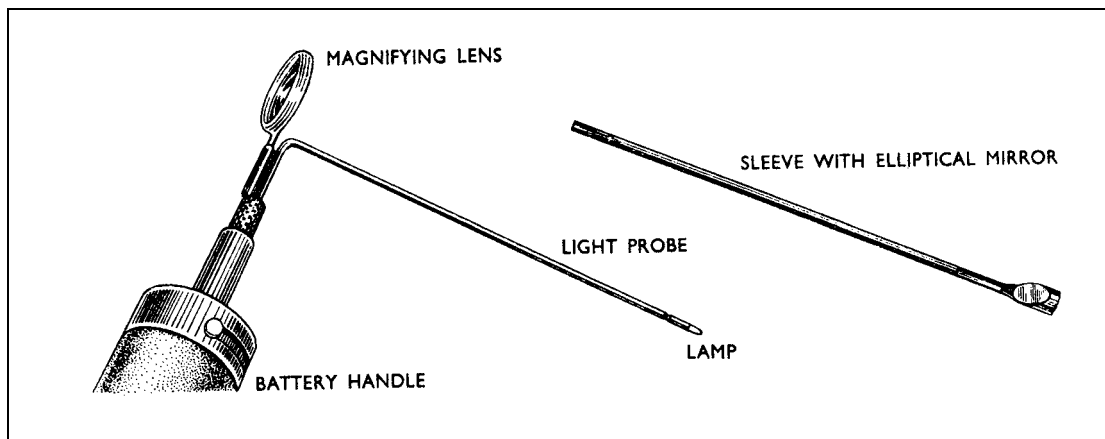

Figure 1 Typical Light Probe

8.2.1 Light Probes

It is obvious that good lighting is essential for all visual examinations and special light probes are often used.

- a) For small boxed-in structures or the interior of hollow parts such as the bores of tubes, special light probes, fitted with miniature lamps, as shown in Figure 1, are needed. Current is supplied to the lamp through the stem of the probe from a battery housed in the handle of the probe. These small probes are made in a large variety of dimensions, from 5 mm ($\frac{3}{16}$ in) diameter with stem lengths from 50 mm (2 in) upwards.
- b) Probes are often fitted with a magnifying lens and attachments for fitting an angled mirror. Such accessories as a recovery hook and a recovery magnet may also form part of the equipment.

- c) For the larger type of structure, but where the design does not permit the use of mains-powered inspection lamps, it is usually necessary to use a more powerful light probe. This type of light probe consists of a lamp (typically an 18 watt, 24 volt type) which is protected by a stiff wire cage and mounted at one end of a semi-flexible tube or stem. On the other end is a handle with a light switch and electrical connections for coupling to a battery supply or mains transformer. As the diameter of the light probe is quite small it can be introduced through suitable apertures to the part of the structure to be inspected.

NOTE: Where spillage or leakage of flammable fluids may have occurred or when inspecting fuel tanks, etc., it is important to ensure that the lighting equipment used is flameproof, e.g. to BS 229.

8.2.2 Inspection Mirrors

Probably the most familiar aid to the inspection of aircraft structures is a small mirror mounted at one end of a rod or stem, the other end forming a handle. Such a mirror should be mounted by means of a universal joint so that it can be positioned at various angles thus enabling a full view to be obtained behind flanges, brackets, etc.

- a) A useful refinement of this type of mirror is where the angle can be adjusted by remote means, e.g. control of the mirror angle by a rack and pinion mechanism inside the stem, with the operating knob by the side of the handle, thus permitting a range of angles to be obtained after insertion of the instrument into the structure.
- b) Mirrors are also made with their own source of light mounted in a shroud on the stem and are designed so as to avoid dazzle. These instruments are often of the magnifying type, the magnification most commonly used being 2X.

8.2.3 Magnifying Glasses

The magnifying glass is a most useful instrument for removing uncertainty regarding a suspected defect revealed by eye, for example, where there is doubt regarding the presence of a crack or corrosion. Instruments vary in design from the small simple pocket type to the stereoscopic type with a magnification of 20X. For viewing inside structures, a hand instrument with 8X magnification and its own light source is often used.

- a) Magnification of more than 8X should not be used unless specified. A too powerful magnification will result in concentrated viewing of a particular spot and will not reveal the surrounding area. Magnification of more than 8X may be used, however, to re-examine a suspected defect which has been revealed by a lower magnification.
- b) When using any form of magnifier it is most important to ensure that the surface to be examined is sufficiently illuminated.

8.2.4 Endoscopes (Leaflet F-90)

An endoscope (also known as an introscope, boroscope or fibrescope, depending on the type and the manufacturer) is an optical instrument used for the inspection of the interior of structure or components. Turbine engines, in particular, are often designed with plugs at suitable locations in the casings, which can be removed to permit insertion of an endoscope and examination of the interior parts of the engine. In addition, some endoscopes are so designed that photographs can be taken of the area under inspection, by attaching a camera to the eyepiece; this is useful for comparison and record purposes.

- a) One type of endoscope comprises an optical system in the form of lenses and prisms, fitted in a rigid metal tube. At one end of the tube is an eyepiece, usually

with a focal adjustment and at the other end is the objective head containing a lamp and a prism. Depending on the design and purpose of the instrument a variety of objective heads can be used to permit viewing in different directions. The electrical supply for the lamp is connected near the eyepiece and is normally supplied from a battery or mains transformer.

- i) These instruments are available in a variety of diameters from approximately 6 mm (¼in) and are often made in sections which can be joined to make any length required. Right-angled instruments based on the periscope principle are also available for use where the observer cannot be in direct line with the part to be examined.
- b) A second type of endoscope uses 'cold light', that is, light provided by a remote light source box and transmitted through a flexible fibre light guide cable to the eyepiece and thence through a fibre bundle surrounding the optical system to the objective head. This type provides bright illumination to the inspection area, without the danger of heat or electrical sparking and is particularly useful in sensitive or hazardous areas.
- c) A third type of endoscope uses a flexible fibre optical system, thus enabling inspection of areas which are not in line with the access point.

9 Non-destructive Examination

In cases where examination by visual means is not practicable or has left some uncertainty regarding a suspect part, the use of one of the methods of non-destructive examination will normally determine the condition of the part.

9.1 A brief outline of the methods of non-destructive examination most commonly used on aircraft structures is given in the following paragraphs. For further information on these and other methods reference should be made to the Part 4 series of Leaflets. The selection of the method to be used will depend largely on the design of the structure, its accessibility and the nature of the suspected defect.

9.2 Penetrant Dye Processes (Leaflet F-20 and F-40)

These processes are used mainly for checking areas for those defects which break the surface of the material, which may be too small for visual detection by 2X magnification and where checking at higher magnifications would be impractical. Basically, the process consists of applying a red penetrant dye to the bare surface under test, removing after a predetermined time any excess dye and then applying a developer fluid containing a white absorbent. Any dye which has penetrated into a defect (e.g. crack) is drawn to the surface by the developer and the resultant stain will indicate the presence and position of the defect.

NOTE: Penetrant dye processes of inspection for the detection of surface defects require no elaborate equipment or specialised personnel. It is emphasised that the cleanliness of the surface to be tested is of prime importance if this process is to reveal microscopic cracks.

9.2.1 The manufacturer's detailed instructions regarding the applications of the process should be carefully followed. The most suitable processes for testing parts of aircraft structures 'in situ' are those which employ water-washable dye penetrants, with the penetrant and developer contained in aerosol packs.

9.2.2 The characteristics of the red marks, such as the rapidity with which they develop and their final size and shape, provide an indication as to the nature of the defect revealed.

- 9.2.3 After test, the developers should be removed by the method prescribed by the process manufacturer and the protective treatment should be restored.

NOTE: A similar process to the Penetrant Dye Process is the Fluorescent Penetrant Process. However, this process is less adaptable for testing aircraft parts 'in situ' because portable 'black light' lamps are used to view the parts and dark room conditions are generally required.

9.3 **Radiographic Examination** (Leaflet F-60)

The use of radiography will often facilitate the examination of aircraft structures and it is used for the detection of defects in areas which cannot be examined by other means because of inaccessibility or the type of defect.

- 9.3.1 Radiography can be a valuable aid to visual inspection and the examination of certain parts of an aircraft structure by an X-ray process will often result in a more comprehensive inspection than would otherwise be possible. However, radiographic methods can be both unsatisfactory and uneconomical unless great care is taken in the selection of suitable subjects. In this respect the opinion of the aircraft manufacturer should be sought.

- 9.3.2 During routine inspections, the use of radiography based on reliable techniques of examination can result in more efficient and rapid detection of defects. In some instances, defects such as cracking, loosening of rivets, distortion of parts and serious corrosion of the pitting type can be detected by this method. It should be borne in mind, however, that a negative result given by a general NDT method such as radiography is no guarantee that the part is free from all defects.

- 9.3.3 Where radiography is used for the detection of surface corrosion it is recommended that selected areas should be radiographed at suitable intervals, each time simulating the original radiographic conditions, so that the presence of corrosion will become apparent by a local change in the density of succeeding radiographs.

- 9.3.4 The accurate interpretation of the radiographs is a matter which requires considerable skill and experience if the maximum benefits are to be obtained. It is essential that the persons responsible for preparing the technique and viewing the results have an intimate knowledge of the structure.

NOTE: Close contact should be maintained with the aircraft manufacturer who will be aware of problem areas on an aircraft and be able to advise on particular inspection techniques.

9.4 **Ultrasonic Examination** (Leaflet F-50)

In some instances ultra-sonic examination is the only satisfactory method of testing for certain forms of defects. Ultrasonic flaw detectors can be used to check certain aircraft parts 'in situ' and it is sometimes an advantage to use this method to avoid extensive dismantling which would be necessary in order to use some other method. The chief value of ultrasonic examination in such circumstances is that cracks on surfaces which are not accessible to visual examination should be revealed. Thus solid extrusions, forgings and castings which are backed by skin panels, but which have one suitably exposed smooth surface, can be tested for flaws on their interface surface without breaking down the interface joint. On some aircraft, spar booms and similar extruded members require periodic examination for fatigue cracks, but the areas of suspected weakness may be inaccessible for examination by the penetrant dye method. In such cases radiography may be recommended, but where ultrasonic testing can be used it will give quicker results on those parts which lend themselves to this form of testing and may also be useful to confirm radiographic evidence.

9.5 **Eddy Current Examination** (Leaflet F-80)

Eddy current methods can detect a large number of physical and chemical changes in a conducting material and equipment is designed specifically to perform particular types of test, e.g. flaw detection, conductivity measurement and thickness measurement.

9.5.1 The main advantages of this method of inspection are that it does not require extensive preparation of the surface or dismantling of the part to be tested and does not interfere with other work being carried out on an aircraft. In addition, small, portable, battery-operated test sets can be used in comparatively inaccessible parts of the structure.

9.5.2 Eddy current testing is usually of the comparative type, indications from a reference piece or standard being compared with indications from the part under test. A technique for detecting a particular fault is established after trials have indicated a method which gives consistent results.

9.6 **Magnetic Flaw Detection** (Leaflet F-70)

Magnetic flaw detection methods are seldom used on aircraft structures and are generally restricted to the manufacturing, fabrication and inspection of parts. The method has, however, sometimes been used where other non-destructive testing methods have proved to be unsatisfactory. Before using the method, the effects of magnetisation on adjacent structure, compasses and electronic equipment should be considered and it should be ensured that the magnetic ink or powder can be satisfactorily removed. If this method is used, demagnetisation and a test for remnant magnetism must be carried out to ensure that there will be no interference with the aircraft avionic systems and magnetic compasses.

INTENTIONALLY LEFT BLANK

Leaflet 51-60 Corrosion of Aircraft Structures

- 1 Recent aircraft experiences have reaffirmed the problems that corrosion can pose to the airworthiness of transport aircraft. The more vulnerable aircraft are those which are 'high time' (age beyond half their original design life aim) when corrosion in conjunction with fatigue can pose serious airworthiness hazards. However, corrosion can also develop soon after an aircraft has entered service with similar consequences.
- 2 Deterioration in material thickness of more than 50% and cracking of airframes induced by corrosion have been found shortly after aircraft have been declared airworthy following a major check in accordance with the maintenance schedule.
- 3 Non-destructive inspection (NDI) techniques have developed significantly over the last decade so that corrosion not readily detectable visually, such as within joints and between faying surfaces, can be detected by eddy current, ultrasonic and mechanical impedance techniques, as appropriate. Development of NDI techniques is a continuing activity and the advice of the aircraft manufacturer should be sought for information on the most effective techniques to be used.
- 4 Aluminium alloys in particular are susceptible to intergranular corrosion (i.e. corrode along the grain boundaries within the metal), thus the removal of superficial products of corrosion followed by re-protection is generally not an effective method of preventing further corrosion. Repair or replacement of the component may be required. All repairs necessitated by corrosive attack, of whatever nature, must be made to an approved repair scheme in accordance with the manufacturer's recommendations. Further information on corrosion is contained in CAP 562 'Civil Aircraft Airworthiness Information and Procedures' Leaflet 51-50.
- 5 Manufacturers' maintenance documentation is being updated to include corrosion control and prevention programmes, which give details of the areas most likely to suffer corrosion and the required maintenance actions. Poorly drained areas, the faying surfaces of joints, fuselage bilges, and structures concealed by sound proofing or hidden below freight bay floors, are typical of the areas liable to corrosive attack requiring particular attention.
- 6 The use of organic water-displacing and corrosion inhibiting compounds is advocated in corrosion control programmes. Normally the compounds approved for use and the areas of application are stated by the aircraft manufacturer. Operators or maintenance organisations applying other compounds have the responsibility to justify technically, to the CAA, the fitness for purpose of those they use. Furthermore, adequate procedures should be in place to ensure that the material procured by the operator or maintenance organisation consistently meets its specification. (See CAAIP Leaflet B-180, Appendix 51-3.)
- 7 The use of corrosion inhibitors does not negate the requirement for a comprehensive inspection as part of a corrosion control programme. Such programmes have mandatory status.
- 8 Operators and maintenance engineers are reminded of the continual need for vigilance to detect the onset of corrosion, particularly where ageing aircraft are concerned. Confirmed evidence of significant corrosion should be reported at once to the manufacturer and to the CAA.

INTENTIONALLY LEFT BLANK

Leaflet 51-70 Inspection of Metal Aircraft After Abnormal Occurrences

1 Introduction

- 1.1 Aircraft are designed to withstand flight and landing loads within specified limits; these limits are calculated to allow for all normal manoeuvres and exercises which may be undertaken by that aircraft and include safety factors to allow for unforeseen circumstances. If design limits are exceeded due to abnormal occurrences, the integrity of the structure may be jeopardised and safety impaired. Any report or evidence on the aircraft which suggests that the design limits have been exceeded or equipment damaged should, therefore, be followed by a careful inspection appropriate to the nature of the occurrence and in accordance with the Approved Maintenance Manual.
- 1.2 The types of occurrence which may lead to structural damage are considered in the following paragraphs, but these should be considered as a general guide and not as a complete list; additional inspections may be required on some aircraft and these will be described in the appropriate manuals. Inspections peculiar to helicopters are described in paragraph 8 of this leaflet and some guidance on the inspection of wooden aircraft structures is given in Leaflet 51-10.
- 1.3 **General**
- The appropriate aircraft Maintenance Manual and other relevant literature, such as Service Bulletins, should be consulted to ascertain the particular inspections which are necessary and the areas where damage has been known to occur in similar circumstances on aircraft of the same type. The aircraft should then be viewed for obvious damage such as distortion or twisting of the main structure, before carrying out the detailed inspections applicable to the particular incident.
- 1.4 The repairs necessary, if damage is found during inspection, are outside the scope of this Leaflet and reference should be made to Leaflet 51-90 and to the manufacturer's Overhaul and Repair Manuals.
- 1.5 The subject headings are as follows:

Paragraph	Subject	Page
1	Introduction	1
2	Heavy or Overweight Landings	2
3	Burst Tyre Incidents	4
4	Tyre Explosion	5
5	Flight Through Severe Turbulence	5
6	Lightning Strikes	6
7	Damage from Jet Blast	7
8	Helicopters	7
9	Other Occurrences	8

1.6 Related CAAIP Leaflets:

- 51-10 Inspection of Wooden Structures
- 51-90 Repair of Metal Airframes
- 51-120 Rigging Checks on Aircraft

2 Heavy or Overweight Landings

- 2.1 An aircraft landing gear is designed to withstand landing at a particular aircraft weight and vertical descent velocity. If either of these parameters is exceeded during a landing, then it is probable that some damage may be caused to the landing gear or its supporting structure. Overstressing may also be caused by landing with drift or landing in an abnormal attitude, e.g. nose or tail wheel striking the runway before the main wheels.
- 2.2 Some aircraft are fitted with heavy landing indicators, which give a visual indication that specified 'g' forces have been exceeded, but in all cases of suspected heavy landings, the flight crew should be consulted for details of aircraft weight, fuel distribution, landing conditions and whether any noises indicative of structural failure were heard.
- 2.3 The damage which may be expected following a heavy landing would normally be concentrated around the landing gear, its supporting structure in the wings or fuselage, the wing and tailplane attachments and the engine mountings. Secondary damage may be found on the fuselage upper and lower skin and structure and wing skin and structure, depending on the configuration and loading of the aircraft. On some aircraft it is specified that, if no damage is found in the primary areas, the secondary areas need not be inspected; but if damage is found in the primary areas, then the inspection must be continued.
- 2.4 Because of the number of factors involved, it is not possible to lay down precise details of the inspections which must be made after any incident, on any type of aircraft, but a preliminary inspection should normally include the items detailed in paragraphs 2.5 to 2.10.
- 2.5 **Landing Gear**
- a) Examine tyres for excessive creep, flats, bulges, cuts, pressure loss, excessive growth and security of balance weights/patches.
 - b) Examine wheels and brakes for cracks, other damage and fluid leaks.
 - c) Examine axles, struts and stays for distortion and other damage.
 - d) Check shock struts for fluid leaks, scoring and abnormal extension.
 - e) Examine landing gear attachments for signs of cracks, damage or movement. In some instances this may require removal of certain bolts in critical locations, for a detailed magnetic crack detection test.
 - f) Examine structure in the vicinity of the landing gear attachments for signs of cracks, distortion, movement of rivets or bolts and fluid leakage.
 - g) Examine doors and fairings for damage and distortion.
 - h) Jack the aircraft and carry out retraction and nose-wheel steering tests in accordance with the approved Maintenance Manual; check for correct operation of locks and warning lights, clearances in wheel bays, fit of doors and signs of fluid leaks.

2.6 Mainplanes

- a) Examine the upper and lower skin surfaces for signs of wrinkling, pulled rivets, cracks and movement at skin joints. Inertia loading on the wing will normally result in wrinkles in the lower surface and cracks or rivet damage on the upper surface, but stress induced by wing-mounted engines may result in wrinkles on either surface.
- b) Check for signs of fuel leaks and seepage from integral tanks.
- c) Examine root end fillets for cracks and signs of movement.
- d) Check flying controls for freedom of movement; power-controlled systems should be checked with the power off.
- e) Check balance weights, powered flying control unit mountings and control surface hinges for cracks and the control surfaces for cracks or buckling.
- f) Where possible, check the wing spars for distortion and cracks.

2.7 Fuselage

- a) Examine fuselage skin for wrinkling or other damage, particularly at skin joints and adjacent to landing gear attachments and centre section.
- b) Examine pressure bulkheads for distortion and cracks.
- c) Examine, for distortion and cracks, the supporting structure for heavy components such as galley modules, batteries, water tanks, fire extinguishers, auxiliary power units, etc.
- d) Check that the inertia switches for the fire extinguishers, emergency lights, etc., have not tripped.
- e) Check instruments and instrument panels for damage and security.
- f) Check ducts and system pipes for damage, security and fluid leaks.
- g) Check fit of access doors, emergency exits, etc. and surrounding areas for distortion and cracks.
- h) Check loading and unloading operation of cargo containers and condition of cargo restraint system.
- i) Check gyroscopic instruments for erection time, precession and unusual noises.

2.8 Engines

- a) Check engine controls for full and free movement.
- b) Examine engine mountings and pylons for damage and distortion. Tubular members should be checked for bow greater than prescribed limits and cracks at welds. Mounting bolts and attachments should be checked for damage and evidence of movement.
- c) On turbine engines check freedom of rotating assemblies and on piston engines check freedom of rotation with sparking plugs removed.
- d) Examine engine cowlings for wrinkling and distortion and integrity of fasteners.
- e) Check for oil, fuel and hydraulic fluid leaks.
- f) Where applicable, check the propeller shaft for shock loading in accordance with the procedure in the Maintenance Manual.
- g) Check propeller attachments and counterweight installations.
- h) Check oil system filters/chip detectors.

2.9 Tail Unit

- a) Check flying controls for freedom of movement.
- b) Examine rudder and elevator hinges for cracks and control surfaces for cracks and distortion, particularly near balance weight fittings.
- c) Examine tailplane attachments and fairings, screw jacks and mountings, for distortion and signs of movement.

2.10 Engine Runs

Provided that no major structural distortion has been found, engine runs should be carried out in accordance with the appropriate Maintenance Manual, in order to establish the satisfactory operation of all systems and controls. A general check for system leaks should be carried out while the engines are running and on turbine engines the run-down time should be checked.

2.11 Inspection of Damaged Areas

If any superficial damage is found during the preliminary inspection, the supporting structure should be examined for distortion, loose rivets, cracks or other damage and rigging and symmetry checks should be carried out; see Leaflet 51-120 to ascertain whether the damage has twisted or warped the main airframe structure. Where flying controls pass through supporting structure, cable tensions should be checked. On pressurised aircraft a cabin leak rate check should be carried out.

3 Burst Tyre Incidents

3.1 Tyre failures on large transport aircraft particularly wide-body types, have resulted in serious incidents and accidents. The principal problem is that if one tyre fails, its axle companion becomes overloaded and sometimes fails. If a tyre bursts during taxiing, take-off or landing, fragments of the tyre may fly off the rotating wheel and cause damage to parts of the aircraft in line with the wheel disc. Where single wheels are employed, more serious damage may occur through the wheel rolling on the paved runway and transmitting shocks to the landing gear leg and supporting structure. Multiple wheel landing gears will generally be less seriously affected by a single burst tyre, but the axles, bogies, torque links or steering mechanism may become bowed or strained as a result of the effects of uneven loading. In some cases extensive damage, including fire, has resulted from tyre and wheel degradation and there has been an attendant reduction in braking performance.

3.2 In most cases the wheel on which the burst occurred will generally be damaged and must be returned for overhaul. In addition, the following inspections should be carried out:

- a) Examine for damage, the wheels and tyres which have not burst.

NOTE: Where one of the tyres on a multi-wheel undercarriage has burst, it may be specified that all tyres on that leg or axle should be discarded, or removed for detailed examination.

- b) Examine the brake units on the affected leg for damage. On those wheels which are not fitted with fusible plugs, the tyre burst may have resulted from overheating caused by a binding brake and when the replacement wheel is fitted attention should be given to the operation of the associated brake including, in particular, freedom of rotation of the wheel with brakes released.
- c) Examine the landing gear bay for damage and hydraulic fluid leaks.

- d) Examine the affected leg, including pipelines, operating jacks, etc., for damage and hydraulic fluid leaks.
- e) Inspect the supporting structure and attachments of the affected leg, for cracks, warped panels and loose rivets. In some instances it may be specified that certain highly-stressed bolts in the supporting structure or retraction mechanism should be removed for non-destructive crack detection tests.
- f) Examine the adjacent fuselage or wing skinning and landing gear doors, for damage.
- g) Check rear-mounted engines for possible ingestion of debris.

4 Tyre Explosion

- 4.1 The majority of in-flight tyre bursts have been attributed to the tyre carcass being weakened by foreign object damage, scuffing, etc., such that a rapid release of pressure takes place. Such failures are usually experienced when the gear has been retracted for some time and the effects of brake heat transfer, internal tyre temperature and differential pressure are combined. However, a tyre inflated with air and subjected to excessive heating, possibly caused by a dragging brake, can experience a chemical reaction resulting in release of volatile gases. Such a chemical reaction in the presence of the oxygen in the contained air may result in a tyre explosion in a landing gear bay and/or an in-flight fire since it appears that the protection normally afforded by conventional pressure relief devices in the wheel would be incapable of responding adequately to the rapid increases in temperature and gas pressure associated with auto-ignition.
- 4.2 Laboratory material and tyre burst testing indicated that the risk of auto-ignition could be reduced by using an inert gas for tyre inflation and servicing. Accordingly, Airworthiness Notice No. 70 (since transferred to CAP 747 Mandatory Requirements for Airworthiness as Generic Requirement (GR) No. 16) was issued prescribing that all braked wheels of retractable landing gear units on aeroplanes exceeding 5700 kg will be required to have tyres inflated with Nitrogen, or other suitable inert gas, and maintain such as to limit the Oxygen content of the compressed gases to not greater than 5% by volume.
 - 4.2.1 Other potential benefits may accrue from the use of Nitrogen as it will tend to reduce wheel corrosion, tyre fatigue and the risk of fire when fusible plugs melt due to brake overheating.
 - 4.2.2 At airfields where suitable inert gases are not normally available, it is acceptable to use air for inflation or servicing provided that a suitable entry is made in the aeroplane Technical Log and that the tyre is reinflated or serviced in accordance with the agreed procedure at the earliest opportunity or within 25 flight hours, whichever is the sooner.

5 Flight Through Severe Turbulence

- 5.1 If an aircraft has been flown through conditions of severe turbulence, the severity of the turbulence may be difficult to assess and report upon, but an indication may be obtained from the accelerometers or fatigue meters fitted to some aircraft. However, these instruments are designed to record steady loads and force peaks recorded during flight through turbulence may be exaggerated due to instrument inertia and should not be taken as actual loads. Generally, if readings exceeding -0.5 g and $+2.5\text{ g}$ are recorded on transport aircraft, then some damage may be found. With other types

of aircraft (e.g. aerobatic or semi-aerobatic), accelerometers and fatigue meters are seldom fitted and reported flight through turbulence should always be investigated.

5.2 Severe turbulence may cause excessive vertical or lateral forces on the aircraft structure and the effects may be increased by the inertia of heavy components such as engines, fuel tanks, water tanks and cargo. Damage may be expected at main assembly points such as the wing-to-fuselage joints, tail-to-fuselage joints and engine mountings. Damage may also occur in those areas of the wings, fuselage, tailplane and control surfaces where the greatest bending moment takes place, i.e. part way along their length and may be indicated by skin wrinkles, pulled rivets or similar faults.

5.3 An inspection for damage, after a report of flight through severe turbulence, should include the inspections detailed in paragraph 2, except, in most cases, those covering the landing gear.

NOTE: Further dismantling and, in some cases, removal of some portions of the skin, may be necessary in order to inspect supporting structure where skin damage has been found.

6 Lightning Strikes

6.1 Lightning is a discharge of electricity between highly charged cloud formations, or between a charged cloud and the ground. If an aircraft is flying, or on the ground in the vicinity of such a cloud formation, the discharge may strike the aircraft and result in very high voltages and currents passing through the structure. All separate parts of an aircraft are electrically bonded together to conduct a lightning strike away from areas where damage may hazard the aircraft, e.g. fuel tanks or flying controls and during manufacture special precautions are often taken with non-metallic components such as wing tips, external fuel tanks and nose cones.

6.2 Lightning strikes may have two effects on an aircraft; strike damage where the discharge enters the aircraft and static discharge damage subsequent to the strike. Strike damage is generally found at the wing tips, leading edges of wings and tail unit and at the fuselage nose, but on some aircraft types other areas may be particularly susceptible and this information should be obtained from the appropriate Maintenance Manual. Static discharge damage will usually be found at wing tips, trailing edges and antennae.

6.3 Strike damage is usually in the form of small circular holes in the exterior skin, either in clusters or spread out over a wide area and often accompanied by burning or discolouration, blisters on radomes and cracks in glass fibre. Static discharge damage is usually in the form of local pitting and burning at trailing edges.

6.4 Inspection

Since both lightning and turbulence occur in thunderstorms, an inspection for lightning damage will often coincide with an inspection following reported flight through severe turbulence. The areas stated in paragraph 6.2 should be examined for signs of strike or static discharge damage and bonding strips and static discharge wicks should be examined for burning and disintegration. All control surfaces, including flaps, spoilers and tabs, should be inspected for damage at their hinge bearings; unsatisfactory bonding may have allowed static discharge and tracking across the bearings, causing burning, break-up or seizure. A check for roughness and resistance to movement at each bearing, will usually indicate damage at such points. In addition, the following inspections should be carried out:

a) Examine engine cowlings and engines for signs of burning or pitting. If a lightning strike is evident, tracking through the bearings may have occurred and some

manufacturers recommend that the oil filters and chip detectors should be examined for signs of contamination; this check should be repeated periodically for a specified number of running hours after the occurrence.

- b) Examine the fuselage skin and rivets generally, for burning or pitting.
- c) If the landing gear was extended when the lightning strike occurred, examine the lower parts of the gear for static discharge damage. Check for residual magnetism and demagnetise where necessary.

6.5 The inspections outlined in paragraph 6.4 should be followed by functional checks of the radio and radar equipment, instruments, compasses, electrical circuit and flying controls, in accordance with the relevant chapters of the approved Maintenance Manual. On some aircraft a bonding resistance check on radomes may also be specified.

7 Damage from Jet Blast

7.1 Considerable damage may be caused to an aircraft through the action of another aircraft turning or taxiing in the vicinity. The damage may be caused by blast or impact from debris and may be particularly severe in the case of light aircraft.

7.2 Flying control surfaces should be inspected for distortion, particularly where they were unlocked and may have been driven hard against their stops.

7.3 An inspection for impact damage in the form of skin dents and cracked or chipped windscreens or windows, should be made and the air intakes for engines, heat exchangers, etc., should be examined for debris which may have blown into them.

7.4 With light aircraft, further inspections may be necessary to ensure that no structural damage has been sustained, particularly when the jet blast has been sufficiently strong to move the whole aircraft.

8 Helicopters

8.1 The inspections necessary on helicopters following unusual occurrences, are broadly similar to those detailed in the preceding paragraphs, but additional checks are normally specified for the main rotor blades, head and shaft, tail rotor and transmission, following heavy landings or flight through severe turbulence. Inspections are also required following overspeeding of the rotors. The inspections outlined below are typical.

8.2 Heavy Landings or Flight Through Severe Turbulence

8.2.1 Rear Fuselage or Tail Boom

Examine for evidence of strike damage from the main rotor blades and if damage is found check for cracks, security and symmetry.

8.2.2 Main Rotor Blades

Remove the rotor blades and examine them for twisting and distortion. Check the surface for cracks, wrinkles, or other damage and check the security of the skin attachment rivets or structural bonding. If the main rotor blades are badly damaged through impact with the tail boom or ground, certain components in the transmission may be shock-loaded and it is sometimes specified that, for example, the main rotor shaft, pitch change rods and main gearbox mounting bolts, should also be removed for inspection.

8.2.3 **Main Rotor Head**

Disconnect pitch change rods and dampers and check that the flapping hinges, drag hinges and blade sleeves move freely, without signs of binding or roughness. Examine the rotor head and blade stops for cracks or other damage and the dampers for signs of fluid leaks. Damage in this area may be an indication of further damage inside the main gearbox.

8.2.4 **Tail Rotor**

Examine the blades for damage and security and the coning stops for evidence of damage. Damage to the tail rotor blades which is beyond limits, will normally entail either inspection or replacement of the hub, pitch change links, tail rotor gearbox and drive shaft.

8.2.5 **Skid Type Landing Gear**

With the helicopter jacked clear of the ground, check cross tubes for excessive bowing, fasteners for integrity and security and abrasion plates for wear. Where Float Gear is fitted, check for leaks, fabric scuffing and integrity of attachment straps.

8.3 **Rotor Overspeeding**

The extent of the inspection will normally depend on the degree of overspeeding. Overspeeding below a specified limit will usually entail checking the rotor blades for distortion and damage and the rotor head for cracks and smooth operation, but, if this limit is exceeded it is usually specified that both the main rotor head and tail rotor head should be removed for overhaul. If damage has occurred to the main rotor blades, the rotor head, shaft, pitch control rods, tail rotor and transmission should also be removed for overhaul and the gearbox attachments should be inspected for damage.

9 **Other Occurrences**

Occurrences not covered in the preceding paragraphs, or peculiar to a particular aircraft type, may necessitate a special inspection and this is often specified in the appropriate Maintenance Manual. Where no specific instructions exist, experience on the type of aircraft, combined with a knowledge of the structure and stress paths, will normally enable a satisfactory inspection to be carried out. As an example, if the flap limiting speed has been exceeded, the flaps should be examined for twisting and buckling, the hinge brackets on the wings and flaps should be examined for damage such as cracks and strained attachment rivets and bolts and the operating mechanism should be examined for general distortion, bowing, cracks and security. Provided these checks are satisfactory and operation of the system reveals no evidence of malfunction, or excessive friction, then the aircraft may be considered airworthy.

Leaflet 51-80 Fatigue Lives

- 1 For fatigue reasons the major components (e.g. wings and centre-sections) of certain types of aircraft have lives restricted to a specific number of flying hours, flight or landings. These restrictions are applicable to certain older, large transport type aircraft. However, it has been found necessary to introduce similar restrictions on certain smaller types of aircraft, some of which are operated for the purposes of Private flight. It should be noted that all Additional Airworthiness Directives relating to fatigue, issued by the CAA on foreign aircraft types, have been removed from CAP 747. Fatigue and Ageing Aircraft issues are being addressed by EASA through their Ageing Aircraft Rulemaking Working Group, MDM.028
- 2 The 'lifing' of components is intended to prevent structural failure under the action of repeated air and ground loads experienced in service, the lives being based on the results of tests carried out by the manufacturers of the aircraft. If the specified fatigue life of a critical component is exceeded, the possibility arises of catastrophic structural failure. Where fatigue lives have been imposed, full details have been published by individual manufacturers in their documentation holding instructions for continued airworthiness and Service Bulletins, and compliance with such information is required by the CAA and EASA. Structural Life limitations are determined for Likely average utilisation of a type of aircraft. Any operations which depart substantially from the typical, require reassessment of the structural life limitations for those specific operations and may require alteration in the Safe Fatigue Lives. Examples of operations in this category are low level flights in a maritime surveillance, or geological survey role (particularly using pressurised aircraft), or long endurance operations.
- 3 For the purpose of establishing structural life limitations a landing is defined as an occasion when the main undercarriage wheels make contact with the airfield surface and lift is significantly destroyed. A flight is associated with each landing and, therefore, the total number of flights pressurised and unpressurised is equal to the total number of landings. A pressurised flight is one in which the aircraft's pressurisation system is operated at a pressure differential of 14 kN/m² (2 lb/in²) or above.
- 4 Because of the transfer of components from one aircraft to another, it has, in some instances, been impossible to establish the remaining safe life of individual components. For this reason it is necessary to ensure that when a component in this category is installed in an aircraft, a record is kept with the aircraft documents showing, as applicable, the hours flown and number of flights or landings already sustained by the component at the time of installation. In the case of pressurised flights the applicable pressure differential may be significant. Certificates of Release to Service may not be signed until the signatory is satisfied that the required history of the component has been established.
- 5 Failure to comply with the above procedure may, due to the absence of evidence showing that the components in question have any remaining safe life, result in owners or operators being required to replace such components prematurely.

NOTE: In addition to recording operating hours of Engines, Auxiliary Power Units and Propellers, the CAA require on most engines, auxiliary power units and propellers that a record be kept of cycles completed. Cycles are defined by the Manufacturer of each engine, auxiliary power unit and propeller.

INTENTIONALLY LEFT BLANK

Leaflet 51-90 Repair of Metal Airframes

1 Introduction

1.1 This Leaflet gives general guidance on repairs to the structure of metal aircraft and should be read in conjunction with the relevant approved publications.

1.2 Repairs must be carried out in accordance with the appropriate Repair Manual or approved repair drawings relative thereto, in conjunction with any other related information contained in other documents recognised or approved by the CAA/EASA.

NOTE: For American manufactured general aviation aircraft, where specific repair manuals or repair documentation is not available, the FAA publication 'Advisory Circular AC 43.13-1B Change 1 Acceptable Methods and Techniques–Aircraft Inspection and Repair' may be used for guidance.¹

1.3 Chapter A6–7 for UK Manufactured Aircraft and B6–7 for Foreign Manufactured Aircraft of British Civil Airworthiness Requirements (BCAR) prescribes that in the case of structural repairs to aircraft where the repairs are of a major nature or not covered in the particular approved manual, the approved organisation or the appropriately licensed aircraft maintenance engineer concerned should advise the nearest CAA area office of the nature of the repair or repairs before work commences (see CAAIP General Information, Contact Details for addresses). Repair schemes not previously approved by the CAA will normally be investigated as modifications in accordance with the procedures in BCAR Chapter A2–5 or B2–5 for Foreign Manufactured Aircraft.

2 Preparation for Repair

2.1 General

Details of the inspections necessary before repair and the methods of assessing the extent of damage, supporting the structure, checking alignment and geometry and assessing allowance for dressing of damage and limits of wear are generally given in the Repair Manual.

2.1.1 In the case of damage not covered by the Repair Manual but which, nevertheless, is thought to be repairable, a suitable repair scheme can often be obtained by application to the aircraft manufacturer (or to a Drawing Office holding the appropriate Design Approval). When supplying information of the damage to the manufacturer, photographs showing details of the damage are often helpful and may save both time and expense.

2.2 Preliminary Survey of Damage

A preliminary survey enables the damage to be classified (e.g. negligible, repairable or necessitating replacement) and a decision to be made as to the preparations necessary before commencing the repair. How the aircraft was damaged or overloaded should be determined as accurately as possible and perusal of the flight crew's or engineering staff's accident report will give guidance to the necessary checks.

2.2.1 Structure distortion which can be evident at the site of the incident, may not be apparent when the aircraft is lifted and the locally imposed loads have been removed.

1. Obtainable from the Superintendent of Documents, U.S. Government Printing Office, Washington, D.C. 20402, U.S.A.

Therefore, the aircraft should normally be inspected on the site where the damage occurred and the damage and distortion plotted on a station chart and ideally photographed before the aircraft is moved, providing a valuable indicator as to areas that require a more detailed inspection.

- 2.2.2 Depending on the results of the preliminary survey, the expected duration of the repair work and the precautions necessary as a result of local conditions, it may be necessary (among other things) to remove the batteries, drain the fuel system and/or inhibit the engines.

2.3 **Supporting the Aircraft**

If the aircraft requires lifting to facilitate the repair operations or supporting to avoid distortion of structural parts during dismantling, the aircraft should preferably be placed in the rigging position (see Leaflet 51-120). To ensure that the aircraft has not moved during the progress of the repair a daily check should be carried out by a responsible person, such checks being based on inspections to ensure that seals placed on jacks have not broken and, at the other end of the range, theodolite checks carried out against established references.

- 2.3.1 Trestling and jacking equipment is usually designed for this operation by the aircraft manufacturer and will facilitate any alignment, rigging or functioning checks necessary during or after repair. With large aircraft it is essential to follow the jacking instructions laid down by the aircraft manufacturer and to use the recommended equipment. The jacks used for these aircraft are usually fitted with a pressure gauge, so that each jack load can be calculated during the lifting operation. In some cases extension and retraction of all jacks used in a lifting operation are controlled from a central source

NOTE: If the fuel system is not drained, the maximum permissible jacking weight should be verified before lifting.

2.3.2 **Additional Support**

In some instances it may be necessary to provide additional support or temporary bracing in order to prevent distortion or movement of the airframe during removal of primary structure such as stressed skin and other load bearing panels; this is usually provided by means of adjustable trestles and/or jury bracing devices.

2.3.3 **Adjustable Trestles**

Adjustable trestles are often made up from specially designed sets of steel members which can be bolted together to form trestles of various sizes. The sets usually contain top cross-beams, adjustable at each end by means of screw jacks, which can be fitted with wooden formers shaped to the contour of the structure they are required to support. To avoid damage to the structure, the formers should be lined with a layer of felt or similar cushioning material, which must be dry and free from extraneous matter (particularly swarf) and covered with polythene sheeting. Rubber should not be used for lining.

- a) Prior to use, the trestles should be checked for correct assembly and it is important to ensure that the maximum permissible load will not be exceeded.
- b) Trestling positions or 'strong points' where trestles may be positioned are given in the Maintenance and Repair Manuals and may also be stencilled on the aircraft. The positioning of the trestles in relation to these points should be carefully supervised, since supporting an aircraft at other than recognised load-bearing positions may result in considerable damage.

2.3.4 When adjustable trestles or jacks are being used to support a structure during repair, the adjusting mechanism, controls, etc., of such should be locked to prevent inadvertent movement whilst repairs are in progress.

2.3.5 **Jury Structures**

Special bracing devices, often referred to as 'Jury' structures, are sometimes needed to take the loads carried by structural parts before they are removed or cut for repair purposes. A jury structure may consist of no more than a length of timber cramped or bolted to the structure, or it may be a specially made strut or jig designed to prevent movement and distortion by holding various key points of the structure in their correct positions. When such devices are made up locally, it must be ensured that they conform in every way with the requirements of the Repair Manual, especially with regard to strength and accuracy of dimensions.

2.4 **Alignment and Geometry Checks**

In instances where the airframe has sustained unusually high loading, structural distortion may have occurred. Although in most instances there will be visual evidence (e.g. skin wrinkling, cracking of paint at the joints of structural members, loose rivets, etc.), this is not always the case and alignment and geometry checks should be made. Similarly, if the aircraft has been damaged by impact, malalignment and distortion of the structure may have occurred in areas remote from the initial impact point in addition to the damage which may be clearly visible at the impact point.

2.4.1 The control and structural integrity of an aircraft are, to a large extent, dependent on the correct alignment of its separate components, not only in themselves but in their relationship one to another and malalignment may result in the imposition of stresses of such magnitude that a premature structural failure could occur. It is therefore essential that alignment is checked before, during and after repair work and guidance on this is given in Leaflet 51-120.

2.5 **Cleaning**

When the structure requires cleaning, this should be carefully supervised, otherwise useful evidence may be lost (e.g. the products of corrosion will help in locating corroded parts and the presence of a dark dusty substance at a structural joint will indicate fretting). Where mud, oil or other extraneous matter has to be removed, the cleaning solutions should be those given in the Repair or Maintenance Manual. Where a fire has occurred, it is important to remove all traces of fire extinguishant and smoke deposits as soon as possible, as some of these products promote rapid corrosion.

2.5.1 It is important that the cleaning fluids specified in the manual are used in the strengths recommended and in applications where their use has been specified. Cases have arisen where cleaning fluid in combination with kerosene has had a deleterious effect on aircraft structure, the penetrating quality of kerosene promoting seepage into skin joints. Such cases are particularly troublesome and it becomes difficult to diagnose the cause of corrosion. Unspecified cleaning fluids may contaminate or destroy pressure cabin and fuel tank sealing media and should not be used.

3 Inspection Before Repair

Structural damage can result from a variety of causes, such as impact, corrosion, fatigue, fire and overloads due to heavy landings or turbulence. In every case careful inspections must be made to ascertain the full extent of the damage and to ensure

that other damage not necessarily associated with the particular incident is also rectified. The applicability of all repair schemes involved should be established as soon as possible by reference to the Repair Data, so that if none is given to cover the case in point, delay is avoided in making application to the aircraft manufacturer for a suitable scheme. Guidance on the nature of the inspections to be made and subsequent repairs is given in the following paragraphs.

3.1 **Cracks**

Care should be taken that cracks, however minor they appear to be, are not overlooked. Where visual inspection is not completely satisfactory, especially at points of concentrated stress, one of the methods of non-destructive examination described in Part 1, Chapter F should be used.

3.2 **Corrosion**

Particular attention should be given to evidence of corrosion.

3.3 **Scores and Abrasions**

Where a score or abrasion in a stressed part is within the limits specified in the Repair Data for blending out into a smooth surfaced shallow depression, it is often necessary to submit the part to one of the non-destructive testing processes described in the Part 4 series of Leaflets. This will ensure that minute cracks are detected and included in the assessment of damage.

3.4 **Bolted Joints**

Checks should be made on all bolted joints in the locality of the damaged area, or where overstressing is suspected, for evidence of bolt and associated hole damage. Where no obvious sign of movement is detected, sample inspection by removal of bolt(s) is often advised. (For bolted joint inspection see also Leaflet 51-110).

3.5 **Skin Panels**

3.5.1 Where buckling of a skin panel is apparent, a careful check of the area and related structure should be made for loose bolts, loose or sheared rivets, cracks and distortion. This should include any remote positions where the loads induced by the particular incident may have spread. In some instances where buckling is within limits specified in the Repair Manual, schemes are provided for fitting a strengthening member, otherwise a new panel should be fitted after any associated structure has been repaired.

NOTE: Loose rivets are often indicated by grey or brown stains around the head.

3.5.2 Where denting in skin panelling is in the form of a smooth and fairly circular depression and no other damage is present, it may in some cases, be considered negligible provided the ratio between the depth and area of the depression is within the limits given in the Repair Data. For example, if a depression of 1.2 mm (0.05 in) is within the limits of the depth permitted, then provided the smallest linear dimension across the depression is not less than fifteen times the depth of the depression the damage may be considered negligible. In the example given above the smallest linear dimension permitted would be 1.2 mm x 15 = 18 mm (0.05 in x 15 = 0.75 in).

3.6 **Internal Inspection**

The internal inspection of a structure is particularly important since damage or defects can often be present without any outward indication. In instances where the damage is extensive, the whole structure should be inspected. Guidance on the internal inspection of structures, together with the various aids which may be used to

facilitate the inspection, is given in Leaflet 51-50, which should be read in conjunction with this Leaflet.

NOTE: In areas where sealants are used (i.e. integral tanks and pressure cabins), structure inspection is made more difficult and it may be necessary to remove the sealant at sample areas to ensure that the structure is free from damage. The sealant should be removed using only the solvent specified and eventually restored strictly in accordance with the instructions given in the relevant manual or repair scheme.

3.7 Removal of Damage

In some instances it will be necessary to cut away the damaged material and dress back the surrounding structure. Although it should be ensured that no more material than is necessary is removed, it is necessary to make sure that the adjacent structure to which the repair is to be applied is in a sound condition.

- 3.7.1 When removing riveted structure, care must be taken not to damage those rivet holes which are to be used again (e.g. by burring, enlargement or undercutting) since circular, smooth-edged holes are essential if the risk of failure by fatigue is to be kept to a minimum.

NOTE: A method widely used for removing rivets is to centre-punch the middle of the preformed rivet head and then, using a drill equal in diameter to that of the rivet, drill only to the depth of the rivet head. The area surrounding the rivet should then be supported on the reverse side and the rivet punched out with a parallel pin punch slightly smaller in diameter than the rivet.

- 3.7.2 Bolt holes should be treated with equal care, it being particularly important that the holes in stressed parts should be free from scores or burrs. Where necessary, bolts should be eased with penetrating oil before extraction but it is also necessary to ensure that the oil does not damage adjacent sealing media. Bolts on which the nuts were locked by a peening over process must have the burrs removed to remove the nuts and these bolts must not be used again.

NOTE: A check should be made to note whether the structure 'springs' as bolts are withdrawn. If this occurs interchangeability fixtures should be used when rebuilding the structure to ensure correct alignment and prevent the introduction of locked-in stresses.

- 3.7.3 When damaged panels are to be removed by cutting (i.e. not by dismantling at a production joint) all edges must be free from burrs and notches and trimmed to a smooth finish. It is important that the corner radii of stressed panels are correct and that the dimensions and locations of cuts are within the limits specified in the repair drawing.

- 3.7.4 Special care is necessary when damaged parts are removed by cutting, to ensure that the remaining structure or material is not damaged by drills, rotary cutting tools, hack-saw blades, etc.

- 3.7.5 Repairs in pressure cabin and integral fuel tank areas may involve separation of members riveted and sealed together. Some sealants have considerable adhesion and may cause difficulty in separating the members after the rivets have been removed. Where such separation is necessary, the solvents specified and methods of separation detailed in the Repair or Maintenance Manual must be strictly followed.

NOTE: After repairs in a pressurised area or a fuel tank, either a leak test or a pressure test may be specified in the appropriate manual.

3.8 **Wear**

Where holes are found to be elongated by stress the part must be renewed. However, if elongation is due to wear and is beyond the limits permitted by the Repair Manual, rectification schemes are usually given.

- 3.8.1 The corresponding pin or bolt assemblies should be inspected for wear, distortion, 'picking-up' and shear and where necessary renewed. Lubricating ducts should be checked for obstruction.
- 3.8.2 Where bushed holes are fitted it is usual to renew the worn bush, but where the hole in the fitting has become enlarged so that the new bush is loose, a repair scheme is usually available for reaming out the hole and fitting an oversize bush.
- 3.8.3 When excessive wear has taken place in unbushed holes the fitting should be renewed unless there is an approved scheme available whereby the hole can be reamed oversize and a bush fitted; in some cases an oversize bolt or pin may be specified.
- 3.8.4 Wear in ball and roller bearings should be checked.

3.9 **Fire Damage**

It is extremely difficult to assess the damage caused to a structure which has been exposed to an abnormally high temperature, since apart from the more obvious damage, such as buckling, the mechanical properties of some of the light alloys may be adversely affected, without any apparent indication. In some instances non-blistering of the paint is a good guide that temperatures have not been unduly high but this cannot be taken as a general rule.

- 3.9.1 In some cases an eddy current test can determine the extent of fire or heat damage by measuring the change in conductivity in the material (see Leaflet F-80), but where doubt exists, sample portions of panels, ribs or frames should be cut out for mechanical testing by an approved test house. Where it is not possible to remove such samples the advice of the aircraft manufacturer should be sought.
- 3.9.2 It is generally necessary to renew any parts made from magnesium, plastics or rubber which were in the vicinity of a fire. This applies, for example, to the bag type of fuel tank in contact with a tank bay wall, the other side of which was affected by the fire.

3.10 **Damage by Lightning**

In a properly bonded aircraft, lightning damage is not usually of a major character and can generally be rectified by the application of one of the standard repairs. However, it is important to note that because of the unpredictable nature of the damage it is important to make a thorough inspection of the whole aircraft, its engines, systems and equipment. The most common form of damage is numerous small burns or punctures in the skin of the aircraft, or the disintegration or burning of non-metallic materials on the exterior, e.g. radomes, radio aerial covers and navigation light covers.

- 3.10.1 Where a control surface has been struck, the bearings and hinges should be checked for pitting and/or stiffness due to the passage of the lightning discharge and all control surfaces should be checked for full and free movement.
- 3.10.2 The bonding of the aircraft should be checked as described in aircraft Manufacturers' Manuals.
- 3.10.3 The compasses may have been affected by the magnetising of steel parts near to them and should be checked swung. If the compasses are found to be affected, a landing compass should be used to locate the disturbing magnetic fields and steel parts found to be magnetised should be demagnetised, as described in Leaflet F-70.

3.10.4 When a structure is de-magnetised, the compasses and any instruments having permanent magnets in their mechanisms should be temporarily removed from areas in which degaussing is being carried out.

3.11 **Repair Report**

A report detailing all the repair work and the procedures involved should be compiled. The details of the rectification work necessary should be based on approved repair schemes, the reference numbers and any other relevant details of which should be quoted.

3.11.1 In addition, the report should record any maintenance work, such as mentioned in paragraph 3.8, which could usefully be carried out during the repair work, since this may obviate the need for further dismantling after a relative short period.

3.11.2 According to the nature of the repair, stage inspections will be necessary during the progress of the repair work (e.g. inspection of rivet or bolt holes, inspection of structures before covering for workmanship, protection, security, locking of screw-threaded parts and duplicate inspection of controls. These inspections should be listed on an Inspection Record Sheet in a sequence related to the repair report and should give details of the inspection required.

NOTE: Before any disturbed parts of the aircraft or engine control systems are concealed, they must be inspected in duplicate as prescribed in BCAR Section A, Chapter A6–2, or Section B, Chapter B6–2 for foreign manufactured aircraft.

4 **Repairs**

A repair to a stressed structure usually involves the removal of damaged panels, the complete or partial removal of structural members such as frames, ribs and stringers and the rebuilding of the structure in accordance with the repair scheme. The particular procedure involved will obviously vary with the design of the aircraft but paragraphs 4.1 to 4.3 cover the general aspects of a repair.

NOTE: If the repair is at all extensive it is often advantageous to have the approved repair drawings duplicated and displayed at the site of the repair.

4.1 Materials used for the repair should be checked for correct specification and gauge thickness and, where applicable, heat treated in accordance with specification requirements.

4.2 On completion of bending or forming operations the material must be free from defects such as scratches, scribe marks, hairline fractures on the outside of bends, cracks at edges adjacent to bends, tool marks, twisting and warping.

NOTE: Complete detail parts must be manufactured by suitably Approved Organisations in accordance with the appropriate drawings. The holder of an Aircraft Maintenance Engineer's Licence in Category B is not authorised to certify the manufacture of aircraft parts.

4.3 Where panels are concerned, care is necessary to prevent buckling and distortion, particularly in the case of large panels, which should be allowed to attain the ambient temperature of the repair site before being fitted. Where the application of heat (e.g. by means of an electric blanket) during the fitting of a panel is specified, it is important that the heat application and control should be strictly in accordance with the requirements of the applicable Repair Data.

4.3.1 In some instances the aircraft manufacturer may provide preformed and partially built-up parts for incorporation into the repair (e.g. sections of leading edge fitted with nose ribs, panels fitted with stringers, saddle pieces, bridging joints in stringers, etc.) and

- it should be ensured that such parts are correctly identified and bear evidence of prior inspection.
- 4.3.2 Particular attention should be given to the drilling of holes, which should be circular and free from scores and sharp edges in order to satisfy design requirements. In some cases it may be specified or recommended that holes in stressed parts should be drilled with a drill reamer, or drilled and then reamed to size. It is also important that drills are sharpened correctly so as to produce the intended hole diameter; a drill running off-centre will produce an oversize hole.
- 4.3.3 Where existing rivet holes are to be used again, repair schemes may often call for special repair rivets to be used. These rivets have a slightly larger shank diameter but the same size head. However, when necessary (e.g. due to hole damage), the use of rivets the next size larger than the original may be permitted, in which case it should be ensured that the landing limits between the new rivets and the sheet edge or other rivets are maintained. In instances where blind rivets are used it is usually necessary to replace the original rivet by the next size larger and the same precautions regarding landing limits apply.
- 4.3.4 With some repair schemes the method of riveting may be very similar for a wide range of applications, but may vary in detail according to the location of the repair (e.g. the type of rivet or the pitch may vary). Similar variations may also apply to the type of jointing compound used (e.g. in pressurised areas) and to the protective treatment required. The repair drawing should therefore be studied very carefully for any special instructions.
- 4.3.5 Care is necessary, particularly with large repairs, in keeping swarf out of places where it may present a hazard. This applies to joints, wiring looms, exposed moving surfaces (e.g. jack rams and pulley assemblies) and unsealed bearings, all of which should be protected before work is commenced. When drilling through laminations or lap joints which cannot subsequently be separated for cleaning, it is essential to ensure that the parts comprising the joint are held firmly together during the drilling operation.
- 4.3.6 Before assembling a joint it should be ensured that the contacting surfaces are clean and free from swarf and that all holes and edges are deburred. If specified, jointing compound should be applied evenly before final assembly and riveting and should form a fillet at the edges of the joint when assembly is complete. The manufacturer's instructions regarding the mixing, working and curing time of the jointing compound should be carefully followed.
- 4.3.7 Guidance on the assembly of bolted joints is given in Leaflet 51-110.
- 4.3.8 When repairs have been made to control surfaces, the balance may have been upset by the additional weight of metal or paint. Such surfaces should be checked for balance by the method given in the appropriate manual and the balance corrected as necessary. For reasons of balance the repairs permitted on control surfaces are often limited in area and position.

5 Metal-to-Metal Adhesive

- 5.1 Since a metal adhesive often requires special heating and pressing equipment, its use may be impracticable for repair work. The damaged part should therefore be cut out as shown in the approved Repair Scheme and a new part riveted in position.
- 5.2 It is possible, however, in certain large repairs to obtain from the aircraft manufacturer a built-up section or pre-formed skin panel with parts secured in position by adhesive.

The repair then consists of removing the damaged section complete and riveting the replacement section into position.

- 5.3 When it is necessary to remove parts which are secured with adhesive, e.g. a stringer, this can be done as shown in Figure 1. Care should be taken to avoid damaging any parts or material other than those to be removed.

NOTE: When paint is removed in the area of a metal-to-metal adhesive joint, only the paint stripper stipulated should be used. Some strippers may have a deleterious effect on metal-to-metal adhesives.

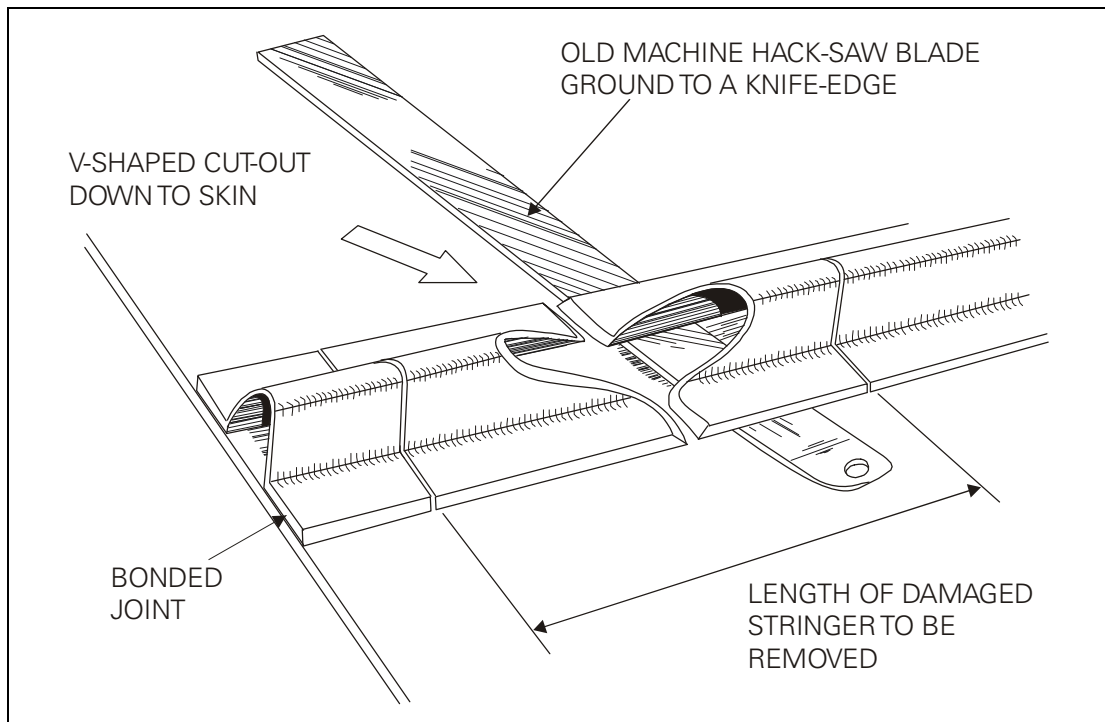

Figure 1 Removal of Bonded Component

6 Repairs by Welding

Repairs by means of welding are often specified for welded structures such as landing gear structures, engine mountings, etc. The welding procedure to be used will depend on the design and manufacture of the structure and will be fully detailed in the Repair Data. It will often be necessary to use jigs or jury structures to ensure that the main structure is held in the correct position during welding.

6.1 Welding Procedures

Some of the welding procedures most commonly used for aircraft repairs are the following: Oxy-Acetylene Welding, Arc Welding and Spot Welding.

- 6.1.1 As prescribed in Chapter A8–10 of BCAR, welders must be approved by the CAA.
- 6.1.2 Where highly stressed components have been repaired by welding they should be submitted to one of the non-destructive examination tests outlined in the Part 4 series of Leaflets.
- 6.1.3 Before welding is commenced any protective treatment in the area of the repair must be completely removed and the parts prepared in accordance with the repair scheme applicable.

6.2 Typical Oxy-Acetylene Welding Repairs

The oxy-acetylene welding technique is more widely used than any of the other methods and in the following paragraphs a brief outline of some oxy-acetylene welding repairs is given.

6.2.1 Welded-Patch Repair

This type of repair illustrated in Figures 2 and 3 is often used for rectifying such damage as cracks, dents, or holes in tubes, provided certain limitations are not exceeded.

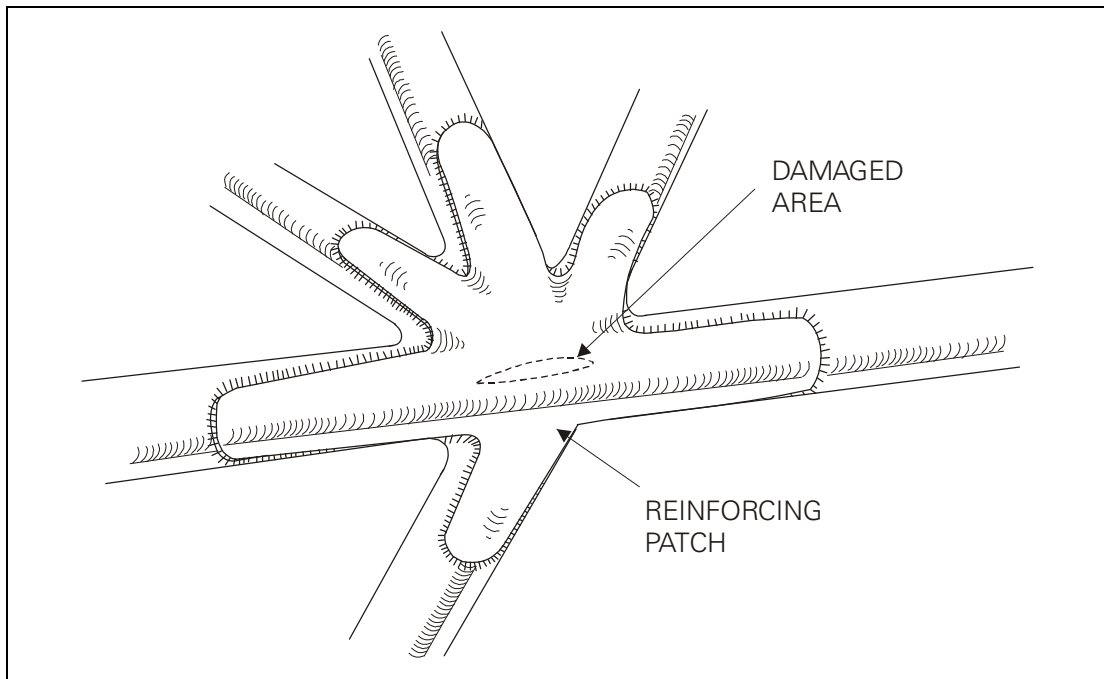

Figure 2 Patch at Tube Joint

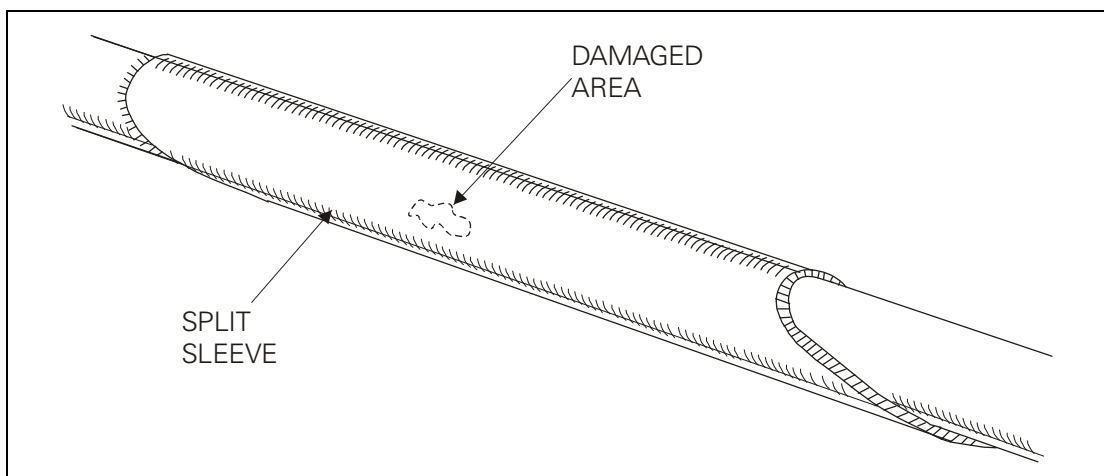

Figure 3 External Sleeve Repair

6.2.2 Partial Replacement – Inner Sleeves

Fairly extensive damage to a tube is often repaired by the use of an inner sleeve splice as shown in Figure 4.

- a) The condition and location of the associated structure should be checked and secured to prevent movement when the damaged portion is removed.

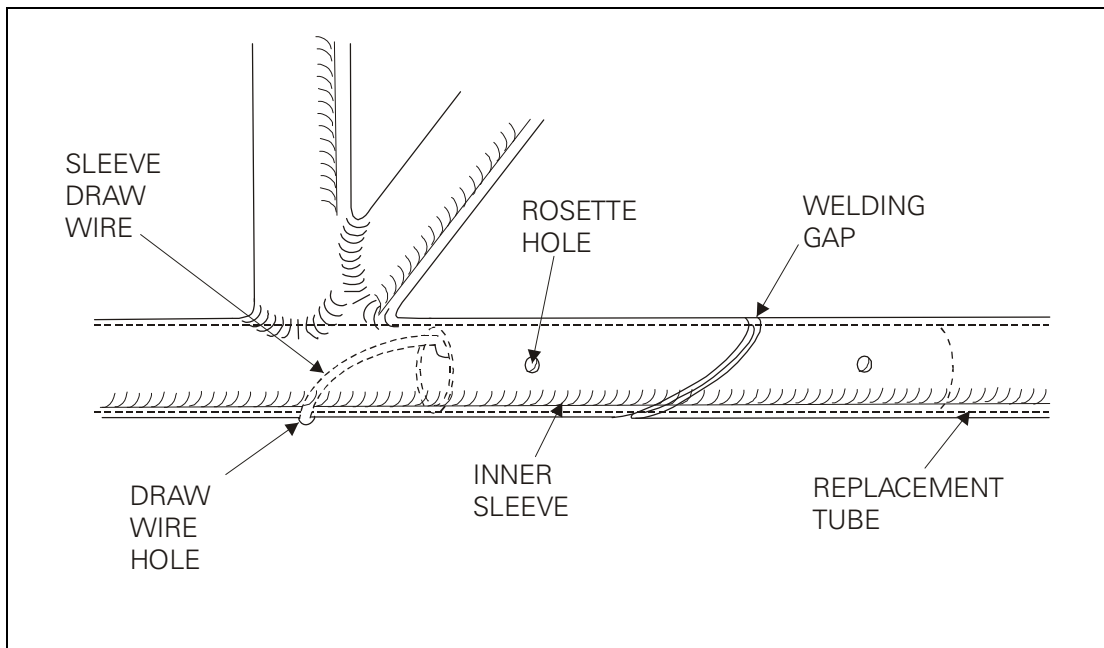

Figure 4 Internal Sleeve Repair

- b) The damaged portion of the tube should be cut out using 30° or 45° diagonal cuts and the burrs inside the tube should be removed.
- c) A replacement piece of tube should be cut to fit where the damaged portion was removed and a gap of approximately 2-4 mm ($\frac{3}{32}$ in) should be left for welding.
- d) The inner sleeves should be cut to length and a check made to ensure that they slide smoothly in both tubes. If rosette holes are required they should next be cut and the burrs removed; when a draw wire is required it should be welded into position.
- e) The inner sleeves should be marked at the half-way position, fitted into the replacement tube and positioned with the midpoint at the diagonal cut.
- f) The repair should be completed by welding at the diagonal cuts and at the rosette holes or the draw wire hole as applicable.

6.3 Partial Replacement – Outer Sleeves

This method should only be used where it is impracticable to use inner sleeves. The procedure is basically the same as for inner sleeves except that the replacement tube should be cut square at both ends and the outer sleeves scarfed at 30° or 45°.

6.4 Protective Treatment

After welding, the parts concerned should be thoroughly descaled, cleaned and the protective treatment restored.

7 Gauging Damage

- 7.1 Where a score, dent, or corrosion damage in a stressed part has been removed by blending out into a smooth surfaced hollow depression, the maximum depth of the depression will have to be measured to ensure that it is within the limits given in the Repair Data. This should be done before applying any protective treatment.

- 7.1.1 A method of gauging the depth of such a depression is by mounting a dial test indicator on a special adaptor block as illustrated in Figure 5. The bottom edge of the block should be straight and radiused to about 1.2 mm (0.05 in) and the dial test indicator (DTI) stem should be at right angles to this edge. The point of the conical anvil should be lightly stoned to avoid scratching the surface of the depression.

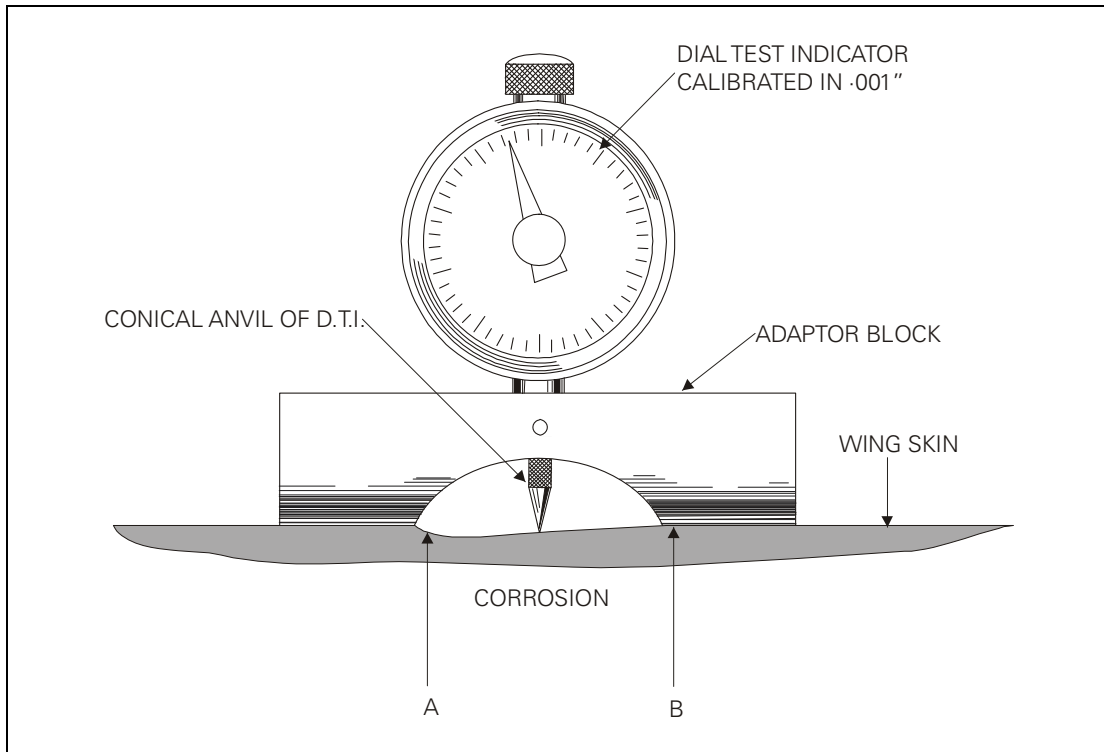

Figure 5 Measurement of Surface Damage

- 7.1.2 When gauging the depth of a depression, a reading should first be taken at two points, adjacent to but unaffected by the depression (such as A and B in Figure 5), then the maximum depth reading (D) should be taken. By subtracting the average of the two point readings $\frac{A+B}{2}$ from the depth reading (D) the actual depth of the depression will be obtained thus:

$$\text{depth of depression} = D - \frac{A + B}{2}$$

7.2 Bowing Limits

To measure the amount of bow in a structural member (e.g. a strut), a straight edge and a set of feeler gauges can be used, providing the part to be measured is free from protruding fittings and the straight edge can be applied directly along the surface of the member. The straight edge should be placed along the entire length of the member and parallel to its axis, then by inserting feeler gauges at the point of maximum clearance the amount of bow can be calculated by the formula:

$$\text{Bow} = \frac{\text{Clearance measured by feeler gauges}}{\text{Length of member}}$$

- 7.2.1 For example, if the length of the member is 2 ft and the clearance measured by the feeler gauge is 0.040 in, the amount of bow is:

$$\text{Bow} = \frac{0.040}{24.0} = \frac{4}{2400} = \frac{1}{600} \text{ or 1 in 600}$$

NOTE: In general a maximum bow of 1 in 600 is normally acceptable unless otherwise stated in the Repair Manual. However, in some instances the manual may permit tolerances for bow greater than this figure.

- 7.2.2 To measure a member which has protruding fittings, a trammel fitted with three pointers can be used to bridge the fittings. The three points should be checked for truth against a straight edge or surface table and adjusted if necessary. The outer points should be placed at the ends of the member and any clearance between the member and the centre point checked with a feeler gauge, the amount of bow being calculated as in paragraph 7.2.1.
- 7.2.3 For more accurate measurement the central trammel point can be replaced by a depth gauge in which case the neutral reading on the depth gauge in relation to the outer points should be carefully noted by checking on a surface table.

7.3 **Curved Sections**

When checking the maximum depth of a depression in a curved surface (e.g. a leading edge), the adaptor block or the trammel must be placed over a line at right-angles to the curvature of the part, i.e. parallel to the longitudinal axis of the curve.

8 **Certification**

The CAA's requirements regarding certification after repair are given in BCAR Section A, Chapter A6–7 or Section B, Chapter B6–7 for foreign manufactured aircraft.

- 8.1 Full particulars of the work done should be entered in the appropriate log book and a Certificate of Release to Service should be signed.
- 8.2 According to the nature of the repair made, the aircraft should be weighed, the Weight and Centre of Gravity Schedule should be amended or replaced by a revised Schedule, a certificate of fitness for flight should be issued and the aircraft should be tested in flight. Particulars and results of such testing must be provided.

INTENTIONALLY LEFT BLANK

Leaflet 51-100 Locking and Retaining Devices

1 Introduction

The purpose of this Leaflet is to provide guidance and advice on the methods of locking screw-threaded components, and the retention or location of circular parts in various assemblies. Chapter D4-1 of British Civil Airworthiness Requirements and EASA CS 25.607 prescribe that an approved means of locking must be provided on all connecting elements in the primary structure, fluid systems, controls and other mechanical systems essential to the safe operation of an aircraft. Information on the assembly and locking of turnbuckles is given in Leaflet 20-80 and on the assembly and inspection of critical bolted joints in Leaflet 51-110.

- 1.1 The purpose of a locking device is to prevent loosening or disengagement of mating components under varying conditions of stress, vibration and temperature as its effectiveness may be of the utmost importance to the safety of an aircraft. Locking devices should be fitted in such a way as to prevent the possibility of fretting, distortion, displacement or uneven stressing of the locked parts.
- 1.2 During inspection of the assembly, it is necessary to ascertain that all locking or retaining devices are of the type and material specified in the relevant drawings or the appropriate publication and that the locking or fitting operation has been correctly performed with the appropriate tools.

2 Split Pins

Split pins are manufactured from corrosion resisting steel and are used in conjunction with drilled bolts and slotted or castellated nuts. The pins should be a reasonably close fit in the nut and bolt/stud assembly. Table 1 indicates the diameters and length of pins normally used in conjunction with bolts/studs up to 1 inch diameter.

Table 1 Split Pin Sizes

Bolt Diameter (inch)	Pin Diameter (inch)		Pin Length (inch)
	British (SP 90)	American (MS 24665)	
1/4 or 2 BA	1/16	1/16	3/4
5/16	1/16	1/16	1
3/8	1/16	3/32	1
7/16	3/32	3/32	1.1/4
1/2	3/32	3/32	1.1/4
9/16	1/8	1/8	1.1/2
5/8	1/8	1/8	1.1/2
3/4	5/32	1/8	1.3/4
7/8	5/32	1/8	2
1	3/16	1/8	2.1/4

NOTE: It will be seen that British and American practice differs with regard to split pin diameters for different thread sizes and care must be taken to ensure that the correct pin is selected for any particular drilled bolt. The size of the split pin hole in the bolt should be checked before fitting the nut.

- 2.1 The legs of split pins should be turned as indicated on the design drawings, but when the method is not specified it is recommended that one of the methods illustrated in Figure 1 should be used. If necessary, pins should be cut to a suitable length to prevent pick-up in clothing, cleaning cloths, etc., and the surplus ends accounted for to prevent their becoming a loose article hazard.

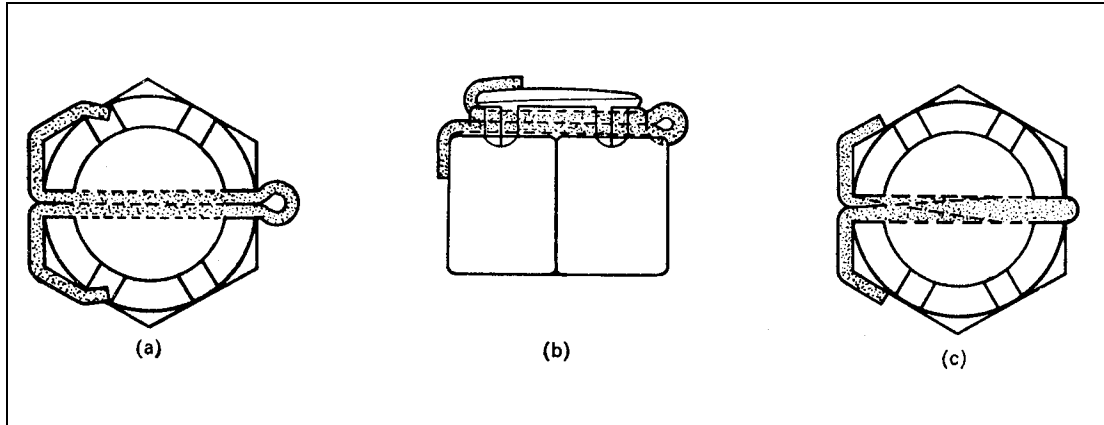

Figure 1 Split Pinning

- 2.2 After turning and closing the legs to the nut faces, an inspection should be made to ensure that cracking or cutting has not occurred at the bends. The most common methods of split pinning are illustrated by Figure 1 (a) and (b). The method shown in Figure 1 (c) is used where clearances are critical.
- 2.3 For bolted joints, one pair of slots must be in alignment with the hole in the bolt when the specified degree of tightness has been obtained. Undrilled bolts should be prepared for drilling by tightening the nut to the specified torque loading and marking the hole position. The nut should be removed and the split pin hole drilled with the aid of a drilling jig. Burrs should then be removed, the nut fitted and tightened to the required torque loading and the correct size of split pin fitted.
- 2.4 In instances where torque loading is not specified, it may be permissible to tighten the nut slightly to achieve alignment, but in no circumstances should a nut be eased back from the normally tight position since this may result in slackness between the parts of the assembly. Nuts must not be filed to facilitate the fitting of split pins. Alignment is more difficult with drilled bolts, and selective assembly of nuts and/or washers may be required.
- 2.5 Split pins should not be used more than once. Split pin holes should not be enlarged, nor split pins filed to facilitate fitting.

3 Locking Washers

There are several types of locking washers in general use consisting of spring washers, cup washers, shakeproof washers, crinkle washers and tab washers (Figure 2).

3.1 Spring Washers

These washers are available in two forms, i.e. as a single coil (SP 47) or as a double coil (SP 55 and 56).

- 3.1.1 In some instances, particularly with light alloy assemblies, spring washers are assembled with plain facing washers between the spring washer and the component,

to prevent damage to the surface of the component or the protective treatment when the spring washer is compressed. Often, however, particularly in steel assemblies, plain washers are not specified.

3.1.2 It is good practice to renew spring washers during overhaul or repair. This is essential in engines and engine components, and units with reciprocating parts, such as compressors or pumps.

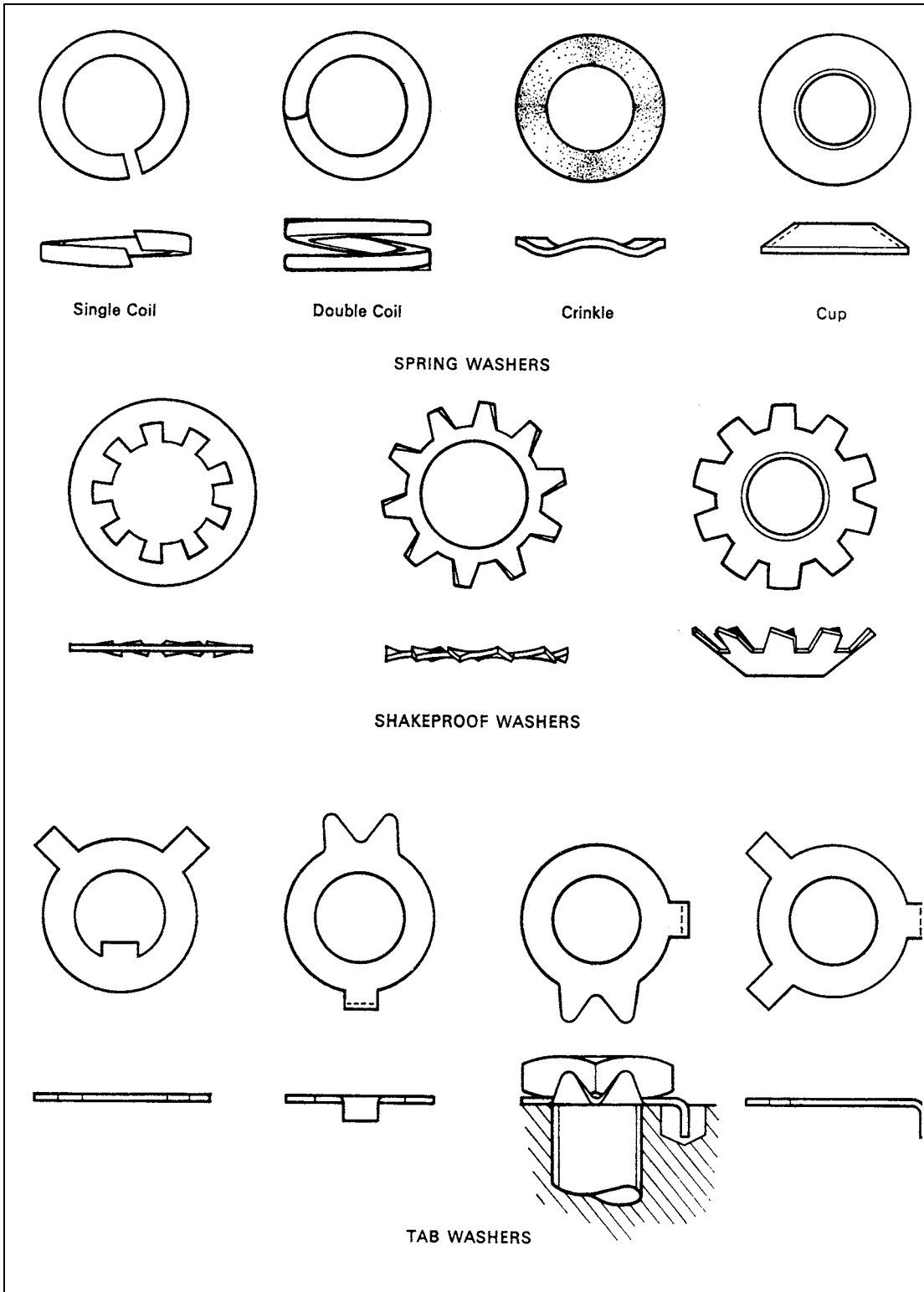

Figure 2 Types of Washers

3.2 **Cup Washers**

These washers (AS 8690 to 8699) are manufactured in spring steel and are dished to form a spring of high rating; assembly should be in accordance with the manufacturer's instructions.

3.3 **Shakeproof Washers**

Flat washers of this type (AGS 2034 and 2035, steel; AGS 2037, phosphor bronze) are sometimes used instead of spring washers and in certain circumstances, conical shakeproof washers (AGS 2036, steel) are used for locking countersunk screws. Either the internal diameter (AGS 2035 and 2037) or external diameter (AGS 2034 and 2036) is serrated, the serrations being set to bite into the component and nut to prevent rotation. Shakeproof washers should only be used once.

NOTE: These washers will not normally be specified in assemblies where anti-corrosion treatment of components has been carried out.

3.4 **Crinkle Washers**

These washers (SP 134 to 138, copper alloy, and SP 139 to 140, corrosion resisting steel) are often used in lightly loaded applications in instrument and electrical installations.

3.5 **Tab Washers**

Tab washers are manufactured from thin metallic sheet materials, to SP 41 to 46 or SP 107 to 112, or to proprietary specifications, and have two or more tabs projecting from the external diameter; they may also be designed for locking two or more nuts. When the washer is fitted, one tab is bent against the component or fitted into a hole provided for that purpose, whilst a second tab is bent against a flat or flats of the nut, after the nut has been correctly tightened down. The component tab should not be bent against a curved surface, since this would permit movement of the washer, and result in loosening of the nut.

3.5.1 Before bending the second tab, an examination should be made of the tab already fixed to ensure that it is not disturbed, sheared or distorted as a result of the washer turning with the nut. When the second tab has been bent, this too should be examined for cracks.

3.5.2 In some assemblies, washers having a tab projecting from the inside diameter are used. The tab fits into a slot machined in the bolt thread or the component hole, whilst an external tab is turned up as described in paragraph 3.5.

3.5.3 Tabs must not be bent more than once. Multiple tab washers may be re-used after removing the used tab, dressing sharp edges, and carefully inspecting the remaining tabs for cracks or scoring.

4 **Locknuts**

Generally, locknuts are thin plain nuts which are tightened against ordinary plain nuts or against components into which male threaded items are fitted, although proprietary locknuts are available which are formed from sheet material. Control rods, swaged-end cables and jack ram eye-end fittings are common examples of the use of locknuts, but in some instances wire locking is also specified. To ensure efficient locking, the bearing surface of the nuts and the component must bed together evenly and the correct degree of tightness must be obtained by applying the stipulated torque loading. It is emphasised that the locknut should not be over-tightened, since this will result in the stripping of the nut threads or over-stressing of the male component. In cases where rotation can occur, the plain nut must be held stationary whilst the locknut is tightened.

5 Locking Plates

Locking plates are usually manufactured from steel. They are placed over hexagonal nuts or bolt heads after these items have been tightened down, and secured, usually by a screw, to an adjacent part of the structure. A typical application is shown in Figure 3.

- 5.1 Locking plates may be used repeatedly provided they remain a good fit around the hexagon of the nut or bolt head.

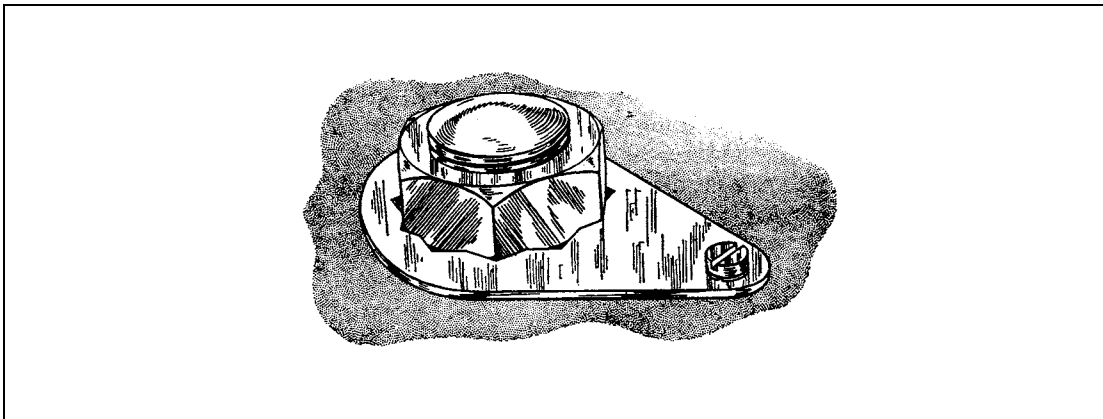

Figure 3 Locking Plate

- 5.2 In certain instances, particularly where vibration is likely, locking plate screws are fitted with spring or shakeproof washers. Some plates may be located by countersunk screws, which may be locked by peening (see Figure 8). Plates may also be provided with a retaining screw slot which permits a limited amount of angular adjustment to suit the position of the nut.

6 Circlips and Locking Rings

Many of these locking devices (see Figure 4) are standard AGS parts manufactured from spring steel wire, sheet or plate, but they may also be specially designed for a particular application. All are hardened and tempered to give inward or outward spring for locking screwed parts together, for locking grub screws (paragraph 10), or for locating components within bores or housings.

- 6.1 Wire circlips have both ends bent whilst other types have drilled ends which facilitate expansion or contraction for fitting into position.
- 6.2 Generally, wire locking rings have one bent end which is inserted into a radial hole drilled through the outer or inner component, depending on whether it is an external or internal type. Locking rings of sheet or plate are seldom provided with a bent end, and the fitting of these entails the use of special expanding/contracting tools and protecting sleeves.
- 6.3 Grooves for circlips and locking rings are semi-circular for wire types and of rectangular section for others. Before fitting, precautions should be taken to ensure that these are free from deformation, burring or dirt.
- 6.4 Inspection should ensure that all of these devices are bedding correctly and that the locking end of locking rings is correctly engaged.

- 6.5 Identification of these devices is difficult and every care should be taken to ensure that the correct items are fitted. Items should be obtained by part numbers and not identified by comparing the old and new, since the diameters of the old are likely to differ considerably from those of new items. Part numbers of the correct part to be fitted should be verified from the appropriate drawings, Overhaul or Repair Manuals or Parts Catalogue.
- 6.6 Some manufacturers stipulate that circlips and locking rings must not be used more than once. However, in some instances, it is specified that the gap between the ends of a circlip or locking ring should, after fitting, be within prescribed limits and as such individual selection may be necessary. The radial position of the gap may also be specified.

7 Wire Locking

Corrosion resisting steel and heat resisting nickel alloy are the materials normally recommended for wire locking, except in the circumstances described in 7.6. Care should be taken to ensure that the wire used is to the correct specification and gauge required by the relevant drawing. In the normal twisting method of wire locking, a suitable length of wire should be cut from the coil and passed through the hole provided for the purpose in the component. The wire should be twisted over the length required to reach the locking point, through which one end of the wire should be passed, and then twisted for not less than a further 13 mm (½inch) whilst being pulled taut. It is necessary to pull the wire taut to ensure that the final twists are close to the locking hole, but neither this nor the twisting should be too severe. After surplus wire has been removed, the twisted ends should be bent in such a manner as to prevent their catching in clothing, cleaning cloths, etc. There should be no untwisted lengths in excess of 9.5 mm (3/8 inch) and lengths of unsupported wire should not normally exceed 76 mm (3 inches).

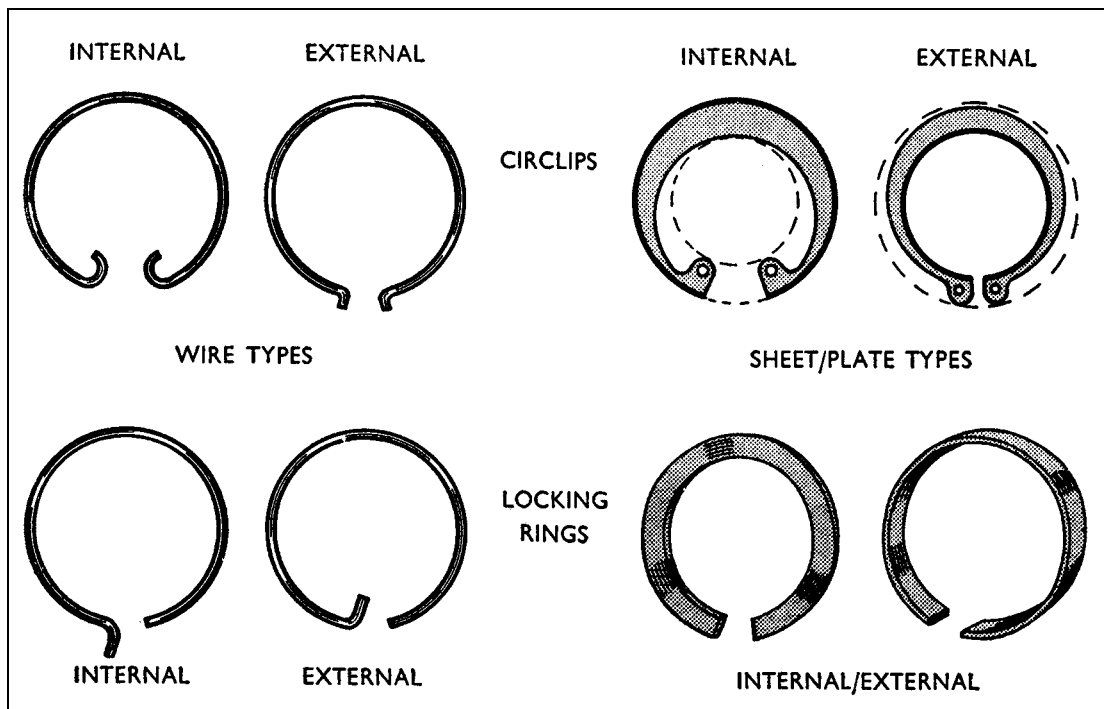

Figure 4 Circlips and Locking Rings

- 7.1 The angle of approach of the wire should not be less than 45° to the rotational axis of the component to be locked (see Figure 5), whilst the line of approach should be tangential to the parts being locked (Figure 6). The lay of the wire must always be such as to resist any tendency of the locked part or parts to become loose, and for this reason it is essential to ascertain whether the parts have left or right hand threads before fitting the wire.

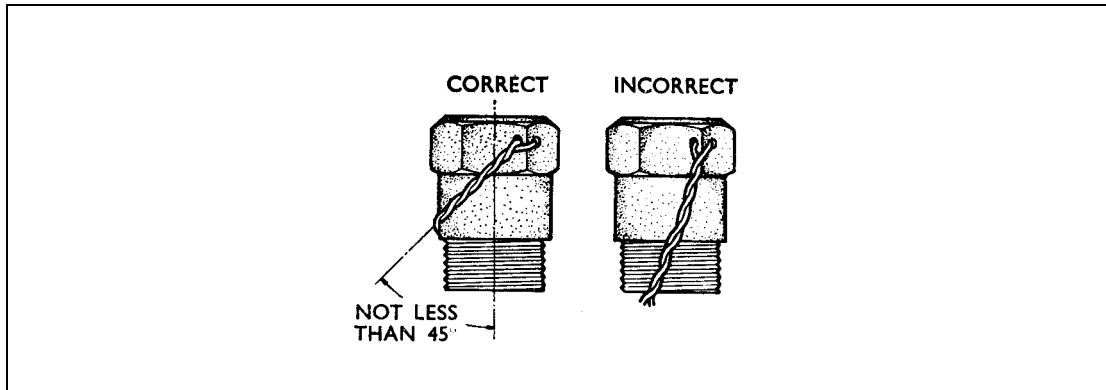

Figure 5 Angle of Approach

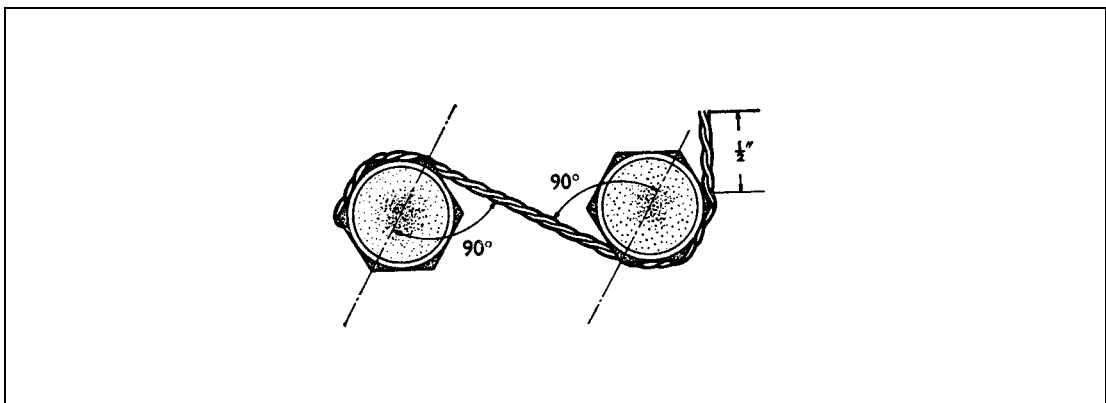

Figure 6 Tangential Approach

- 7.2 In instances where the method of wire locking is not indicated on the drawing, great care is necessary when deciding on a locking method to ensure that there is no possibility of the parts becoming loose. For example, when adaptors are used in pipe joints, it is essential that the adaptor is secured to each union nut by separate locking wires to adjacent corners of the adaptor nut, with the approach angle shown in Figure 5. It may be specified that the adaptor is locked additionally to some external point.
- 7.3 When locking tabs are used, they should be fitted in such a way that the tabs and the wire are in complete alignment. Examples of correct and incorrect use of locking tabs are shown in Figure 7. Whenever possible, the closed end of the wire should be in the tab and the open end at the component to be locked.

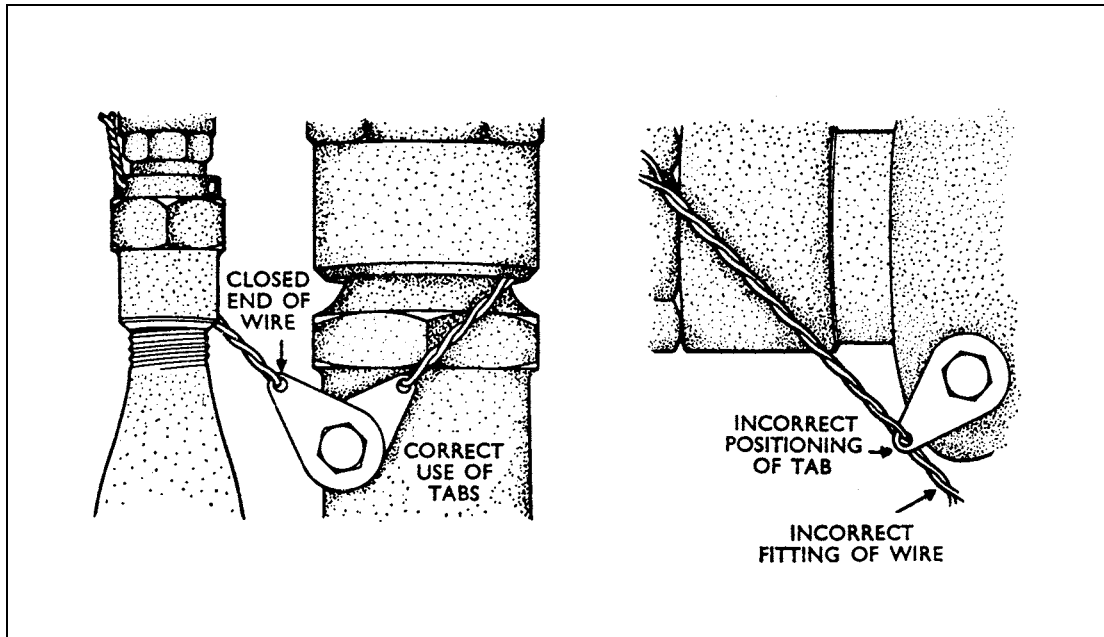

Figure 7 Correct and Incorrect Use of Locking Tabs

- 7.4 Some wire locking is done with a single strand of the specified wire, particularly in instances of complete ring or similar formations of nuts. The wire is passed in sequence through the nut slots and bolt/stud holes around the formation until the wire ends meet. The ends are cut to suit and twisted together to tension the loop. The wire direction through all nuts must be such that any loosening of a nut will further tension the wire.
- 7.5 Locking wire must not be used more than once. The wire must be adequately tensioned; over-tensioning may lead to fracture of the wire, or of the metal around the locking hole. Sharp edges of locking holes must be removed and there must be no obstruction by the locking wire of any moving parts, controls, etc.
- 7.6 In some instances controls or switches are wire locked into their normal operating position and selection of an emergency position necessitates physically breaking the wire. The use of stainless steel wire in these instances could prevent operation of an essential service, and thin copper wire is usually specified. The method of installing this type of locking (sometimes known as 'wire sealing') is normally detailed in the appropriate Maintenance Manual.

8 Self-locking Fasteners

These fasteners include stiffnuts and screws, nuts or bolts in which an inset nylon patch or stud applies friction between the male and female components. To provide effective locking, the friction element in each device must be fully engaged with complete threads on the mating component; with stiffnuts this consideration requires that the male threads extend at least one full thread (not including the chamfer), through the friction element.

- 8.1 Fasteners with a fibre or nylon friction element should only be used once, and must not be used in locations where all-metal stiffnuts are specified. All-metal stiffnuts should not be re-used in locations vital to aircraft safety (e.g. control runs) but may be re-used in other locations provided the locking quality remains satisfactory.

- 8.1.1 Most aircraft manufacturers lay down the assembly conditions (e.g. dry or lubricated) and acceptable limits of in-built torque for the re-use of stiffnuts, and require that each nut should be checked with a torque wrench during assembly.

NOTE: The use of torque wrenches is discussed in Leaflet 20-10.

- 8.1.2 A recognised method of checking the friction elements of small stiffnuts which are not being used in locations vital to aircraft safety is to screw the nut on to the male thread, using finger pressure only. If it is possible to turn the nut far enough for the male thread to protrude through the friction element the locking is unsatisfactory. This test is suitable for small nuts where the torque applied by the fingers approximates to the in-built torque requirement of the nut specification, but is unrealistic for larger nuts.
- 8.1.3 Unsatisfactory locking may also result from a worn male thread. If either of the above tests leads to rejection of a stiffnut the male thread should be closely inspected. If a new stiffnut fails to provide adequate friction then it may be necessary to replace the bolt or stud on which it is to be assembled.

9 Peening

The peening of bolts for locking purposes should only be carried out when specified in the drawing, or the relevant manual, as the operation prevents re-use of the nut and bolt and may cause difficulty in dismantling. About 1½ threads of the bolt should be projecting and the peening carried down to the nut to prevent it slackening. Adequate support should be given to the bolt during the peening operation and care taken to prevent damage to the part by misdirected blows with the hammer. Countersunk screws may be locked by the method illustrated in Figure 8 when the thread is inaccessible. Protective treatment damaged by the peening operation must be restored.

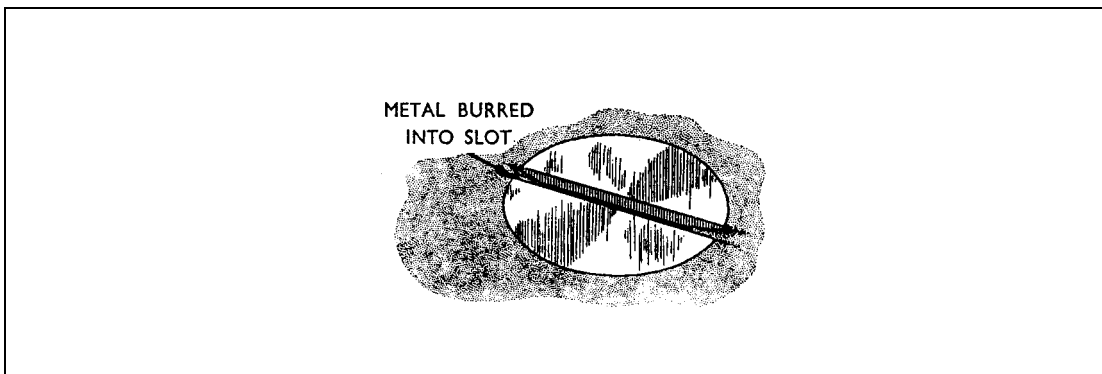

Figure 8 Peening to Lock Countersunk Screws

10 Grub Screws

These are used as a method of locking two threaded components together. In one method the outer component only is drilled and threaded and the grub screw may be machined at the inner end to a tapered point or a parallel plain shank to fit either a conical recess or parallel hole in the inner component. Other grub screws may be fitted into a single hole drilled and threaded in both inner and outer components. Grub screws may be locked by peening using the method illustrated in Figure 8, by a wire type locking ring or by means of a nylon insert in either the male or female thread.

- 10.1 Grub screws are also used, with the variations already mentioned, in non-threaded assemblies to retain the parts and ensure correct alignment. They may be fitted as additional or precautionary locking devices in assemblies with interference fits or bonded joints, or, in some cases, they may be the only means of retention. In these cases, however, several grub screws may be fitted around the component and these may be locked by lock nuts or clamping type lock rings.

11 Taper Pins and Parallel Pins

Taper pins with taper of 1 in 48 and parallel pins, are used on both tubular and solid sections, to secure control levers to torque shafts and forked ends to control rods, etc. Some taper pins are bifurcated and the legs spread for locking, whilst other taper pins, and parallel pins, are locked by peening, or by forming reaction rivet heads. To avoid slackness, the pins are usually assembled in reamed holes, the head being supported during the locking process. Careful inspection is required after fitment of pins through hollow tubes, to ensure that undue force during the peening operation has not bent the pins, and thus impaired the security of the fittings.

12 Locking by Adhesives

- 12.1 Many small components, particularly those in instruments, valves, switches, etc., may be locked by the application of Shellac, Araldite or similar materials to DTD 900 specifications. The adhesive is applied to the outside of the nut face and protruding screw thread, or the component and screw head, after tightening, and prevents movement between the two parts.
- 12.1.1 When using Araldite it is good practice to mix a separate sample under similar conditions, to check that it hardens within the specified time period.
- 12.2 Threaded metal fasteners may also be locked using a liquid sealant such as Loctite. This is an approved proprietary material (DTD 900 Approval No. 4588) which hardens in the screw threads after assembly and is supplied in various grades to give a predetermined locking torque in a variety of applications from stud locking to retaining bearings in housings. In using Loctite it is advisable to have the parts free from grease to achieve maximum strength. It is possible, however, to use Loctite on threaded parts which have not been degreased but retain the original lubrication applied by the manufacturer. In these cases a 15% decrease in the strength of locking usually occurs. Loctite should only be used when specified by the approved drawings or instructions, and applied in accordance with the manufacturer's instructions.

Leaflet 51-110 Assembly and Maintenance of Critical Bolted Joints

1 Introduction

- 1.1 This Leaflet gives guidance on the recommended assembly procedure for critical bolted joints and on the extent to which inspection can verify that design requirements have been met. Guidance is also given on the inspections necessary during maintenance and overhaul to ensure the continued effectiveness of the joint.
- 1.2 In the context of this Leaflet the term 'critical bolted joint' is used to describe any bolted joint or attachment where stress levels are high and where inadequate assembly techniques could result in fatigue failure. Examples of critical bolted joints are spar joints, tailplane attachments, wing attachments and engine mounting structure.
- 1.3 Where specialised procedures or techniques are specified for the preparation or assembly of a critical bolted joint, the manufacturer's published procedures should be referred to and their recommendations observed.
- 1.4 Related CAAIP Leaflets:
 20-10 Torque Loadings
 F-70 Magnetic Flaw Detection
- 1.5 The subject headings are as follows:

Paragraph	Subject	Page
1	Introduction	1
2	Assembly Procedure	1
3	Jointing Compound	3
4	Tightening of Bolts	4
5	Inspection of Bolted Joints	6
6	Locking	8

2 Assembly Procedure

- 2.1 During the initial assembly of a joint, checks should be made to ensure that the component parts are protected against corrosion, that the edges of holes are deburred, chamfered or radiused as appropriate and that mating surfaces are free from swarf or other foreign matter.

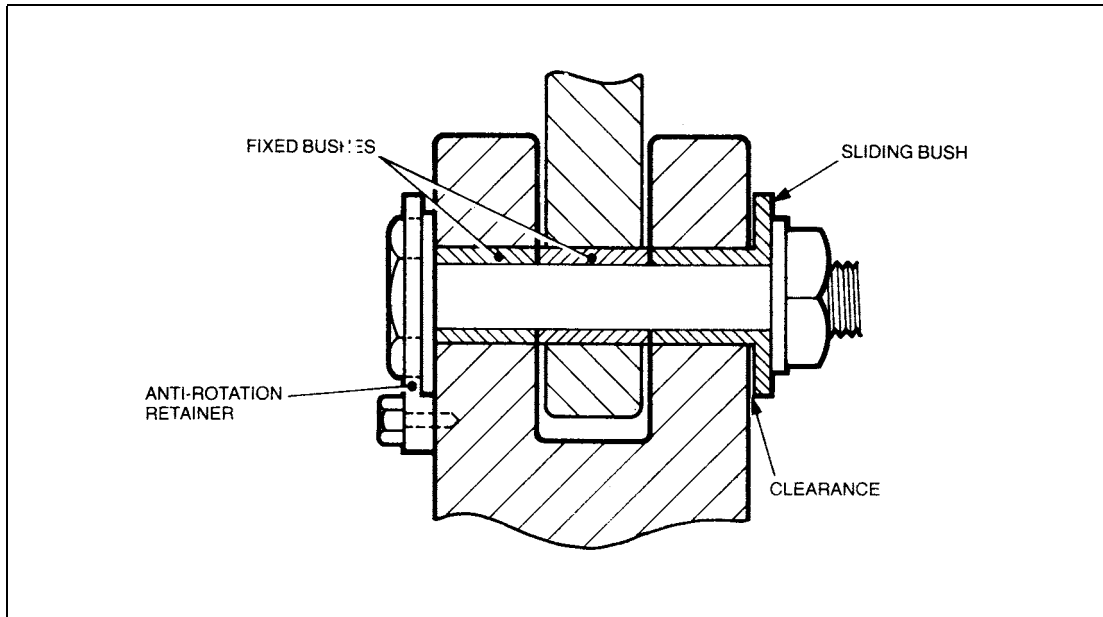

Figure 1 Fork Fitting with Sliding Bush and Anti-Rotation Retainer when Applicable

- 2.2 Before bolts are inserted it must be ensured that parts are correctly assembled and that no mis-alignment is present. Where one component is a fork-type fitting, a sliding bush may be fitted in one arm of the fork; provided that a clearance is maintained between the head of the bush and the fork during tightening of the assembly bolt (Figure 1), stressing of the fork fitting will be avoided. In other cases a good fit is obtained by selective assembly or by fitting shims or washers; if play is present in this type of joint the tightening of attachment bolts will induce a stress and weaken the fork fitting.
- 2.3 In some instances assembly instructions may require good bearing contact between the mating surfaces of the various components and also on the pressure faces of bolt heads and nuts. Tapered bolt holes should be checked by applying engineers blue to the hole and lightly rotating the bolt, while flat surfaces should be checked on a surface table, or by the use of engineers blue or feeler gauges during a trial assembly. Poor bearing surfaces should then be corrected by light lapping. Each hole should be checked using its own assembly bolt.
- 2.4 In some instances the surfaces of bolt holes in critical locations are stressed to prevent crack propagation and fatigue failure. Plastic deformation of the material surrounding the holes is produced by some form of broaching, such as the use of an interference fit mandrel, before the assembly bolt is fitted. In the case of tapered bolts in aluminium alloy components the hole is reamed until the bolt stands proud of the surface by a specified amount then, during final tightening, the tapered bolt expands the hole and induces compressive stress in the hole surface.
- 2.5 When performing operations such as drilling, reaming, lapping, etc., prior to final assembly of a joint, it is essential that the assembly is trued and held securely in position by clamps, slave bolts etc. This will prevent the ingress of swarf between faying surfaces and ensure that the joint is retained in this position when the joint bolts are finally inserted. Greater joint accuracy will be ensured if the joint bolts are inserted in sequence on each side of the joint immediately after each bolt fitting operation.
- 2.6 Parallel holes which have been opened to full size during assembly may be checked for size by means of plug gauges, but in certain instances, particularly when

interference fits are required, the use of more specialised measuring equipment such as a pneumatic bore gauge may be necessary.

- 2.7 Careless fitting or assembly can considerably reduce the fatigue life of a joint. A burr on a bolt, or a piece of swarf left in a hole can scratch the surface of the hole and result in the concentration of stresses. To prevent the scoring of bolts and holes thorough cleanliness must be maintained and if shouldered bolts are used a 'bullet' should be fitted to protect the thread and provide a lead-in for the bolt shank. Lubrication of the bolts is usually recommended and the lubricant (or sealant) should be kept in a sealed container to prevent contamination when not in use. (See paragraph 3).
- 2.8 It will be appreciated that many highly stressed joints will require no hand fitting. The components may be jig built to very fine tolerances which obviate most of the fitting precautions outlined in the preceding paragraphs. However, a high standard of cleanliness and care in handling the components is still necessary if design strength is to be maintained.
- 2.9 Where joints or fittings have more than one bolt, progressive tightening should be carried out in order to prevent stresses being induced. In some cases the final tightening sequence will be stipulated on the appropriate drawing. Nuts should be fitted finger-tight then progressively tightened to the appropriate pre-load value, but new parts may require bedding-in by first tightening to half the pre-load, slackening, then finally tightening in accordance with the manufacturer's recommendations.

3 Jointing Compound

- 3.1 There are a number of different compounds in use which are selected according to the type of joint, the probable frequency of disassembly, the material involved, the method of assembly, the protective treatments applied and the conditions of operation.
- 3.2 Pigmented varnish jointing compound to DTD 369, or other compounds covered by specification DTD 900, are frequently used to prevent scuffing and corrosion in joints and cold-setting polysulphide synthetic rubber materials are often used for joint sealing. Other materials may be specified for use in particular locations and reference should be made to the appropriate aircraft manual for instructions regarding their use.
- 3.3 In joints where hard-setting compounds are specified, precautions should be taken to ensure that the joint is tightened whilst the compounds are still wet, otherwise dimensional tolerances may be seriously affected if the compounds become dry before the joint is tightened.
- 3.4 Care should be taken to ensure that only the specified jointing compound is used, since, for example, that complying with DTD 369 is not suitable where temperatures in the vicinity of the joint may exceed 200°C, whilst hard-setting compounds are unsuitable in areas where vibration may occur.
- 3.5 Jointing compounds will give unsatisfactory results if kept in open containers which allow them to become semi-dry before application and to ensure consistent results from occasional use are often supplied in squeeze-tubes.
- 3.6 Sealants are usually supplied in twin-pack form and mixing instructions should be followed carefully. Once mixed the sealant starts to harden and final assembly of a joint should be completed within a specified application time. Sealant which is not used within its application time must be discarded.

4 Tightening of Bolts

- 4.1 The tension (pre-load) applied to a bolt during tightening should be greater than the highest stress likely to be encountered in service. The most efficient joint would be obtained by tightening each bolt to its yield point but, due to manufacturing tolerances and other variables, the practice would be dangerous to apply; in addition, each bolt could only be used once. A number of other ways of preloading bolts have been devised and although these may result in a less-than-optimum tension, have proved satisfactory in service.
- 4.2 Under-tightening of bolts in highly stressed joints may, when load is applied, result in lack of contact or rigidity between the separate parts of the assembly. Where alternating or fluctuating loads are applied to such joints early fatigue failure may occur. Conversely, over-tightening is likely to cause immediate failure of the bolts or distortion of one or more parts of the assembly.
- 4.3 The general problem of applying a specified pre-load to a bolt is also affected by the need to line up split-pin holes. Unless the bolt pre-drilling suits the joint and nut dimensions, or the bolt is drilled after tightening, the applied pre-load will be inaccurate to the extent of the nut adjustment. In some applications this inaccuracy may be acceptable, but in others the selection of alternative nuts or washers may be recommended.

NOTE: For some installations the bolt head is indexed and must be maintained in the required position by an anti-rotation retainer (see Figure 1).

4.4 Torque Loading

The most common method of pre-loading is by applying a specified torque to the nut during tightening. Laboratory tests are carried out to ascertain an appropriate torque loading for any particular application, taking into account the type of thread, bolt and nut materials, manufacturing tolerances, type of anti-corrosive treatment and type of lubricant. This loading is applied by means of a torque wrench and results in a reasonably consistent pre-load being applied to the bolt. The use of torque wrenches is covered in Leaflet 20-10.

4.5 Pre-load Indicating Washers

The value of the pre-load applied to a fastener by means of a torque wrench may vary considerably and, because of this, specified torque loadings are usually low compared with the actual strength of the fastener. In certain critical bolted joints the manufacturer may consider that more accurate clamping is required and specify the use of pre-load indicating (PLI) washers.

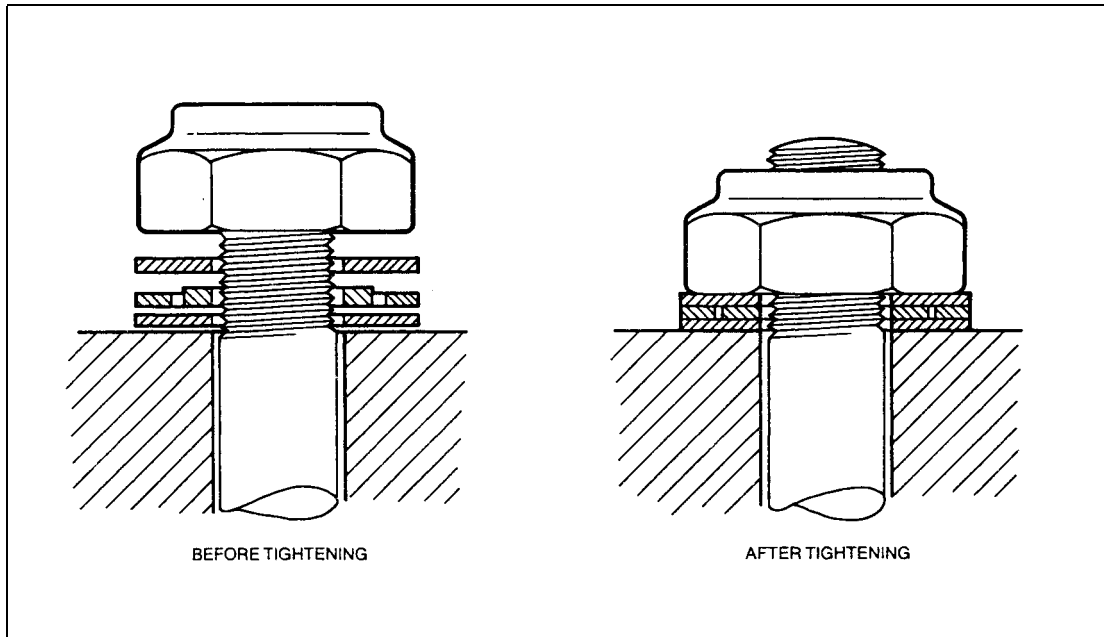

Figure 2 Pre-load Indicating Washers

- 4.5.1 PLI washers consist of concentric inner and outer rings and two high-strength steel washers as shown in Figure 2. The outer ring is thinner than the inner ring and has a series of radial holes drilled through it.
- 4.5.2 A stiff wire tool is inserted in holes in the outer ring and used to check whether the ring is free to rotate (Figure 3). As the nut is tightened the inner ring is compressed until, at a predetermined pre-load, the outer ring is nipped between the washers; at this point the outer ring can no longer be rotated and tightening is complete.

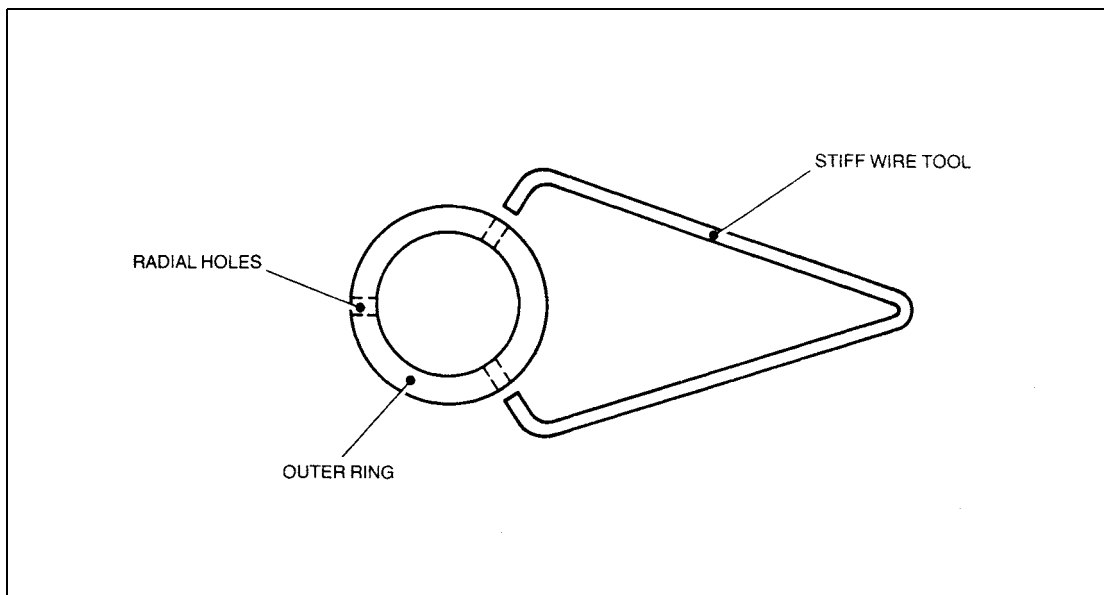

Figure 3 Checking PLI Washer for Rotation

- 4.5.3 PLI washers are unaffected by thread or nut friction, or by lubrication and provide a means of pre-loading a bolt which is more consistent than torque loading. The pre-load applied to the particular size of bolt can be varied to suit its application by changes in the material or dimensions of the inner ring. However, since the inner ring is

compressed during tightening it can only be used once and if slackened must be replaced.

4.5.4 Due to the method of tightening, PLI washers can only be used with self-locking nuts.

4.6 **Shear Type Fasteners**

A number of proprietary fasteners are available which permit a reasonably accurate pre-load to be applied to a bolt without the use of torque wrenches. The nut normally used has an upper hexagonal wrenching portion, separated from the main nut by a deep groove. The hexagon portion shears off during tightening when a predetermined clamping force is reached.

4.7 **Bolt Extension**

An accurate method of pre-loading which, unfortunately, cannot often be used in airframe applications for reasons of inaccessibility, is the measurement of bolt extension. The bolts are tightened until a specified extension has taken place, as measured by means of a micrometer or similar instrument.

4.8 **Dished Washers**

These washers are sometimes used on dynamically loaded structures. The washers consist of circular discs of constant thickness and have an initial 'dish' raising the centre, so that when nipped they act as a spring of very high rating and will accommodate a certain amount of stretch in the bolt shank, or bedding-in of the head. By variation of the thickness, outer diameter and height, a wide variety of load deflection characteristics can be obtained, but unlike pre-load indicating washers, there is no reliable way of ensuring when optimum tightness has been reached.

4.9 **Standard Spanners**

The use of standard spanners is seldom recommended as the only method of tightening a critical bolted joint. British Standard 192 gives the lengths of spanners to be used with the different sizes of nuts and this leverage is usually adequate for general engineering work. It would, however, be impossible for even a skilled operator to apply a consistent amount of pre-load to a variety of bolt sizes. A reasonably accurate torque loading could be applied, in emergency, by using, for example, a double ended ring spanner and a spring balance, with the direction of pull at 90° to the spanner. The balance reading multiplied by the spanner length would give the torque loading applied.

NOTE: In certain installations the material of the component dictates use of special tools or protection from contact with standard tools.

5 **Inspection of Bolted Joints**

5.1 Unless bolts are extracted, visual examination is unlikely to reveal the faults which are usually associated with the beginning of cracks, fretting, corrosion etc. However, visual inspection is important as a means of checking that there are no indications of movement in the joint and that the external protective treatment is in good condition.

5.2 At the periods specified in the approved Maintenance Schedule, bolts should be extracted to enable a detailed examination to be made. Although this can be done most conveniently if the joint is broken down during major overhaul, on some aircraft one or more bolts may be required to be removed from critical joints at more frequent intervals. Whenever bolts are to be removed from these joints it will be necessary to support the surrounding structure in such a way as to remove the loads normally taken by the joint. The supports should be adjusted so that no residual loads are

present in the joint when the bolts are removed and this may often be checked by fine adjustments to the supports until the bolts rotate easily. Bolts may often be removed by means of a suitable extractor but, if the bolts are tight or stuck because of the presence of corrosion products or jointing compound, it may be preferable to punch them out with a drift. Extreme care is necessary to avoid damaging the bolt threads as this could result in damage to the hole and induce stress failure; it is also advisable to support the structure round the head of a bolt using a hollow dolly.

5.3 **Examination of Bolts**

When bolts are removed they should be examined for signs of steps, cracks, fretting or corrosion. An appropriate type of non-destructive testing must be used when checking for cracks, the electromagnetic process being suitable for most steel bolts. See Leaflet F-70.

- 5.3.1 Where applicable, the protective coating should be examined for condition and, if the plating is scored or partially rubbed away, the bolt should either be replated or discarded.
- 5.3.2 The threads should be thoroughly cleaned and examined to ensure freedom from damage. Failure to do this may result in excessive friction between the bolt and nut and lead to incorrect preloading if a torque wrench is used.
- 5.3.3 If, after examination, a doubt exists regarding the serviceability of the bolts, they should be rejected.

5.4 **Examination of Bolt Holes**

The bolt holes should be examined for signs of scoring, fretting, corrosion and cracks. A preliminary examination should be made before the hole is cleaned, since this is the most suitable time for detecting corrosion deposits, but it may be found that jointing compound obscures much of the hole surface.

- 5.4.1 The hole should be cleaned out with a suitable solvent, such as trichloroethylene and then reinspected.
- 5.4.2 The inspection of bolt holes can sometimes be difficult, but an optical aid such as an endoscope is often used and eddy current methods are also frequently recommended.

5.5 **Fretting**

Examples of aircraft components which have failed through fatigue originating in areas of fretting, have shown that fractures do not necessarily pass through adjacent bolt holes.

- 5.5.1 Fretting at major joints is often revealed, by black or grey dust or paste in aluminium structures and brown rust stains in steel parts, at the periphery of faying surfaces. Cracks may develop from the outer edge of a fretted area and extend across the component. An examination of a component showing signs of fretting should, therefore, include the flat surfaces as well as the bolt holes.
- 5.5.2 An inspection of this nature would entail disassembly and examination by means of penetrant dye, eddy current or ultrasonic (surface wave) methods.

5.6 **Reassembly of the Joint**

When reassembling the joint the assembly recommendations given in the preceding paragraphs should be taken into consideration.

6 Locking

Locking devices must be sufficiently effective to prevent loosening or turning of the threaded parts and they should be fitted as specified in the relevant drawing or manual. Most locking devices may only be used once, but those which can be re-used should be checked for effectiveness before being refitted.

Leaflet 51-120 Rigging Checks on Aircraft

1 Introduction

This Leaflet gives guidance on methods of checking the relative alignment and adjustment of aircraft main components and should be read in conjunction with the appropriate manual for the aircraft concerned. Guidance on checking the rigging of aircraft after abnormal flight loads or heavy landings is given in Leaflet 51-70.

2 Levelling the Aircraft

The position or angle of main components is related to a longitudinal datum line parallel to the aircraft centre line and a lateral datum line parallel to a line joining the wing tips. Before these positions or angles are checked, the aircraft should (generally) be brought to the rigging position (i.e. with the lateral and longitudinal datum lines horizontal) by means of jacks or trestles, depending on the particular aircraft type, with the wheels just clear of the ground.

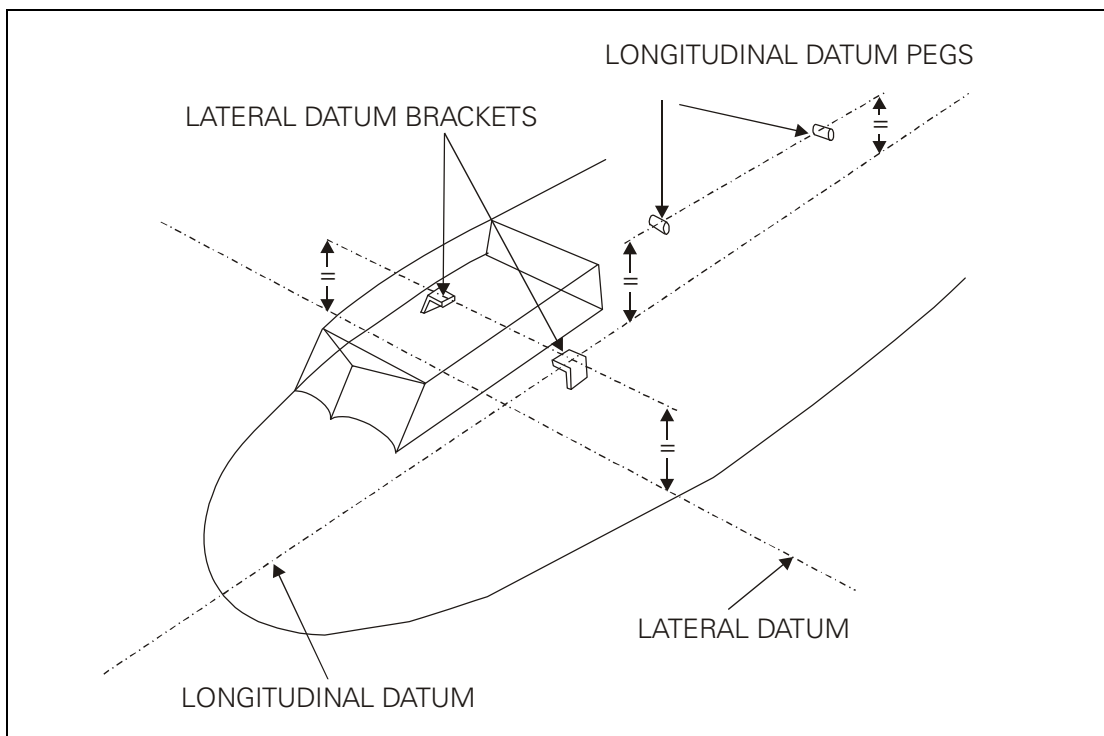

Figure 1 Datum Lines and Levelling Points

- 2.1 For the purpose of checking the level of smaller types of aircraft, fixed or portable datum pegs or blocks, on which can be rested a straight-edge and spirit level and which are generally attached to the fuselage parallel to or co-incident with the datum lines, are used, although in some instances parts of the structure which run parallel with the datum lines (e.g. top longerons or canopy rails of some aircraft) may be utilised. A typical levelling arrangement is shown in Figure 1.
- 2.2 The methods of checking the levelling given in paragraph 2.1 are also applicable to many of the larger types of aircraft, but other methods are sometimes used, e.g. the 'grid' method illustrated in Figure 2. The grid plate is a permanent fixture on the floor

of the aircraft and, when the aircraft is to be levelled, a plumb bob is suspended from a predetermined position in the roof of the aircraft over the grid plate. The adjustments necessary to the lifting gear to bring the aircraft to the level position are indicated by the grid scale, true level being obtained when the plumb bob is immediately over the centre point of the grid .

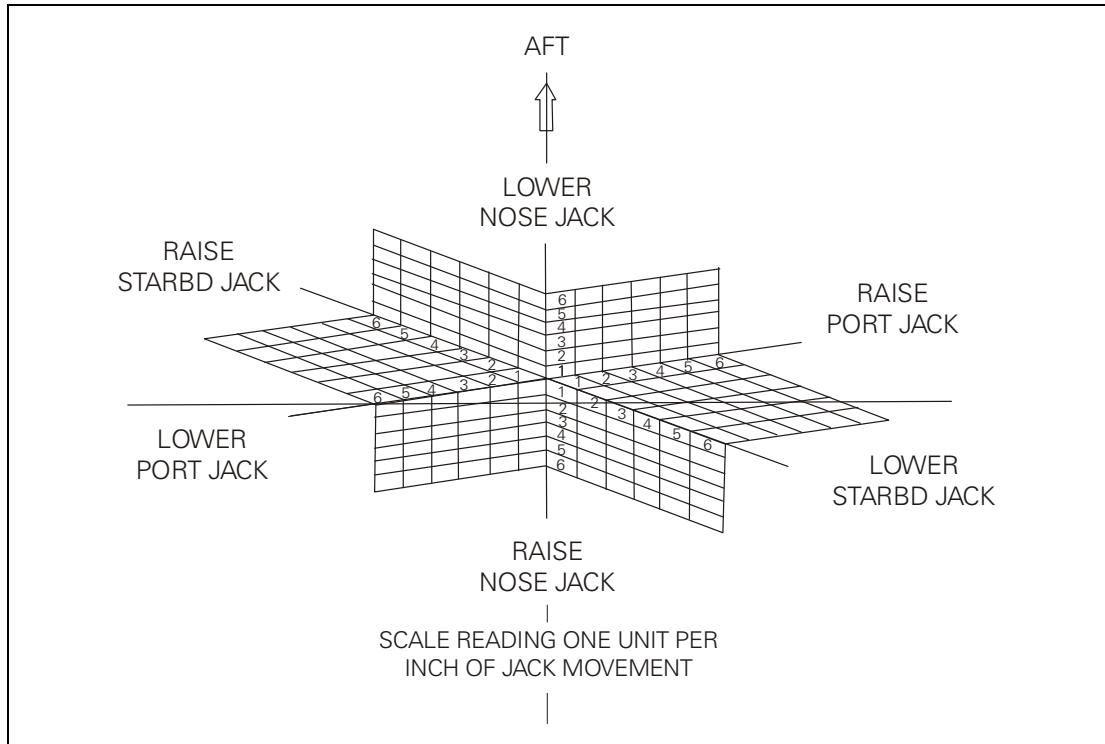

Figure 2 Typical Grid Plate

- 2.3 The method of bringing the aircraft to the rigging position depends largely on the size and type of aircraft and whether a nose wheel or tail wheel configuration applies, the general procedures applicable to each case being given in paragraphs 2.9 and 2.10 respectively. However, there are certain precautions which must be observed in all instances and guidance on these is given in paragraphs 2.4 to 2.8. Guidance on precautions to be taken when lowering the aircraft is given in paragraph 4.
- 2.4 A level site capable of bearing the load to be applied should be selected for the operation otherwise, where trestles are used, it may not be possible to level the aircraft and where jacks are used, the danger of the jacks toppling and dropping the aircraft would exist.
- 2.5 Rigging checks should not normally be undertaken in the open, but if this is unavoidable the aircraft should be positioned nose into wind. In any case the aircraft should not be lifted in strong winds or gusts.
- 2.6 The weight and loading of the aircraft for the rigging check should be exactly as described in the manual or as quoted on the original rigging chart supplied by the manufacturer. Variations from this condition, especially in the case of larger aircraft, will prohibit a comparison with the original figures. In any case the aircraft should not be lifted until it is ensured that the maximum jacking weight (if any) specified by the manufacturer will not be exceeded.
- 2.7 All equipment which may cause damage to the aircraft during the lifting operation should be moved away before lifting is commenced and no personnel other than

those directly connected with the rigging check should be permitted on or around the aircraft for the duration of the complete operation.

- 2.8 For most aircraft the brakes should be OFF and the wheels chocked prior to lifting but for aircraft fitted with levered suspension undercarriage units the wheels should be left unchocked.

2.9 **Tail Wheel Aircraft**

- 2.9.1 The tail should be raised to an approximately level position by means of the appropriate jacks or adjustable trestle accurately positioned under the rear lifting position. Where single-engine aircraft in particular are concerned, it may be necessary to weight down the tail to prevent the aircraft nosing over due to the weight of the engine. This weight must not be allowed to swing but must touch the ground and be secured by a taut rope to that part of the aircraft specified by the manufacturer.

- 2.9.2 The appropriate jacks or adjustable trestles should be accurately positioned under the main lifting points and the aircraft raised evenly by operating both jacks or trestle gears together until the wheels are just clear of the ground and the aircraft is in the (approximate) rigging position.

- 2.9.3 The lateral and longitudinal levels should be checked and adjusted as necessary by means of the lifting gear. Where hydraulic jacks are used, the locking devices provided must be applied immediately the aircraft has been correctly positioned and, to ensure the safety of personnel, at any time when the jack is not actually being operated during the lifting of the aircraft.

- 2.9.4 If steady trestles are placed under the wings after the aircraft has been supported in the rigging position, it must be ensured that they are not in contact with the wings when incidence or dihedral checks are being made, that no adjustments are made to the lifting gear with the steady trestles in position and that the trestles are removed before any attempt is made to lower the aircraft (see paragraph 4).

2.10 **Nose Wheel Aircraft**

The appropriate trestles or jacks should be accurately positioned under the main, nose and (if applicable) tail positions. The main and nose lifting gear should be operated simultaneously and evenly until the aircraft is just clear of the ground and the operation completed as described in paragraphs 2.9.3 and 2.9.4.

3 **Rigging Checks**

Although the dihedral (see paragraph 5.2) and incidence (see paragraph 5.5) angles of conventional modern aircraft cannot be adjusted (with the possible exception of adjustable tailplanes) they should be checked at specified periods and after heavy landings or abnormal flight loads (see also Leaflet 51-70) to ensure that the components are not distorted and that the angles are within permitted limits. The relevant figures together with permitted tolerances are specified in the appropriate manual for the aircraft concerned, but the actual figures relevant to an individual aircraft are recorded in the aircraft log book.

- 3.1 The usual method of checking rigging angles is by the use of special boards (or the equivalent) in which are incorporated or on which can be placed an instrument for determining the angle, i.e. a spirit level or clinometer as appropriate. On a number of aircraft the rigging can be checked by means of sighting rods and a theodolite. Guidance on rigging checks with rigging boards is given in paragraphs 3.3 and 3.4 and on the use of sighting rods in paragraph 3.5.

3.2 Sequence of Rigging Checks

A suitable sequence for checking the rigging is as follows; it is essential that the checks should be made at all the positions specified in the relevant manual.

- a) Wing dihedral angle(s)
- b) Wing incidence angle(s)
- c) Engine alignment
- d) Tailplane lateral level or dihedral
- e) Tailplane incidence angle
- f) Verticality of fin
- g) Symmetry check

3.3 Checking Aircraft with Rigging Boards

3.3.1 Dihedral

The dihedral angle should be checked in the specified positions with the special boards provided by the aircraft manufacturer or, if no such boards are provided, with a straight-edge and clinometer. The methods of checking with both types of board are shown in Figure 3.

NOTE: Certain portions of the wings or tailplanes may sometimes be horizontal or, on rare occasions, anhedral angles may be present.

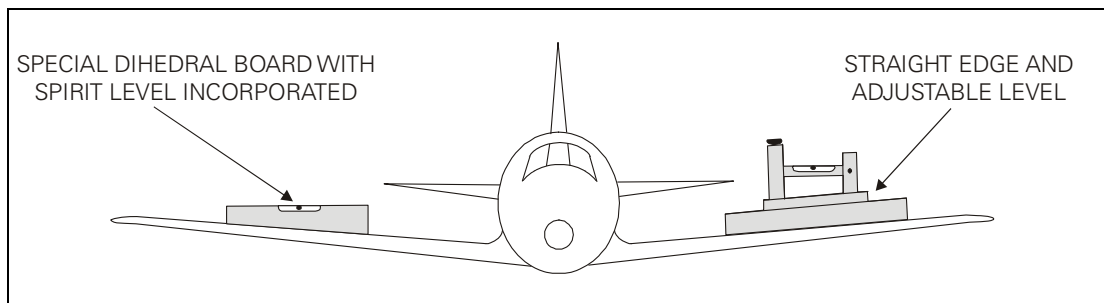

Figure 3 Checking Dihedral

3.3.2 Incidence

The incidence is usually checked in at least two specified positions, inboard and outboard, on the component to ensure that it is free from twist.

- a) There are a variety of types of incidence boards, some having stops at the forward edge which must be placed in contact with the leading edge of the wing, whilst others are provided with location pegs which fit into some specified part of the structure, but the main purpose in each case is to ensure the board is fitted in exactly the position intended and, if the rigging is correct, that a clinometer on the top of the board will register zero or within a permitted tolerance about zero. In most instances the boards are kept clear of the wing contour (so that the incidence check is not influenced by any irregularities which may occur in the contour) by means of short feet attached to the board. A typical wooden incidence board is shown in Figure 4 although, of course, some are manufactured of metal.
- b) It must be borne in mind that modifications in areas where incidence boards are located may affect results. For example, if leading-edge deicing shoes were fitted

this might seriously affect the position taken up by a board having a leading edge stop as shown in Figure 4.

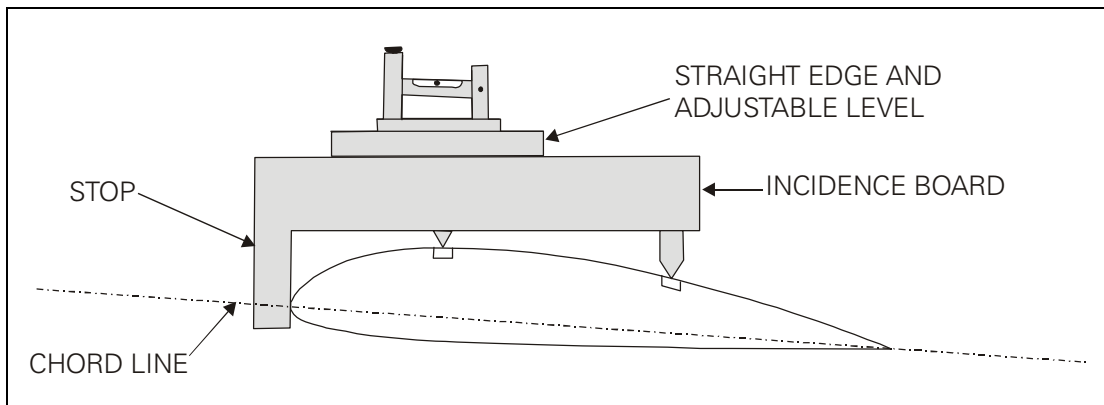

Figure 4 Typical Incidence Board

- c) Where possible, the verticality of the incidence board should be checked with a plumb bob. Where the checks are being taken in the open (see paragraph 2.5) and it is difficult to steady the plumb bob due to wind, the suspension of the plumb bob in a container of oil or water will be of assistance.

3.3.3 Verticality of Fin

After the rigging of the tailplanes has been checked, the verticality of the fin relative to a lateral datum can be checked from a given point on either side of the top of the fin to a given point on the port and starboard tailplanes respectively; the measurements should be similar within prescribed limits. When the verticality of the fin stern post has to be checked, it may be necessary to remove the rudder and drop a plumb bob through the rudder hinge attachment holes, when the cord should pass centrally through all the holes. It should be noted that some aircraft have the fin offset to the longitudinal centre line to counteract engine torque.

3.3.4 Engine Mountings

Engines attached to the wings are usually mounted with the thrust line parallel to the horizontal longitudinal plane of symmetry but not always parallel to the vertical longitudinal plane, since, due to their disposition along the wing, the outboard engines are often offset a degree or so to enable the slipstream from the propellers to converge on the tailplane. The check to ensure that the position of the engine, including the degree of offset, is correct depends largely on the type of mounting, but usually entails a measurement from the centre line of the mounting to the longitudinal centre line of the fuselage at a point specified in the relevant manual. (See also Figure 5).

3.3.5 Symmetry Check

Figure 5 illustrates the principle of a typical symmetry check, the relevant figures and tolerances for which will be found in the appropriate manual, although the actual measurements relating to the aircraft concerned are given in the aircraft log book.

- a) For the smaller types of aircraft the measurements between points are usually taken by means of a steel tape. It is recommended that a spring balance should be used on the longer distances to obtain an equal tension, 5lb usually being sufficient.
- b) Where the larger types of aircraft are concerned, it is more usual to chalk the floor locally under the positions where the dimensions are to be taken, to drop plumb

bobs from the checking points, marking the floor with an 'X' immediately under the point of each plumb bob and then to measure the distance between the centre of the markings. This method has the advantages of ensuring more accurate measurement and reducing the amount of walking necessary on main planes and tailplanes.

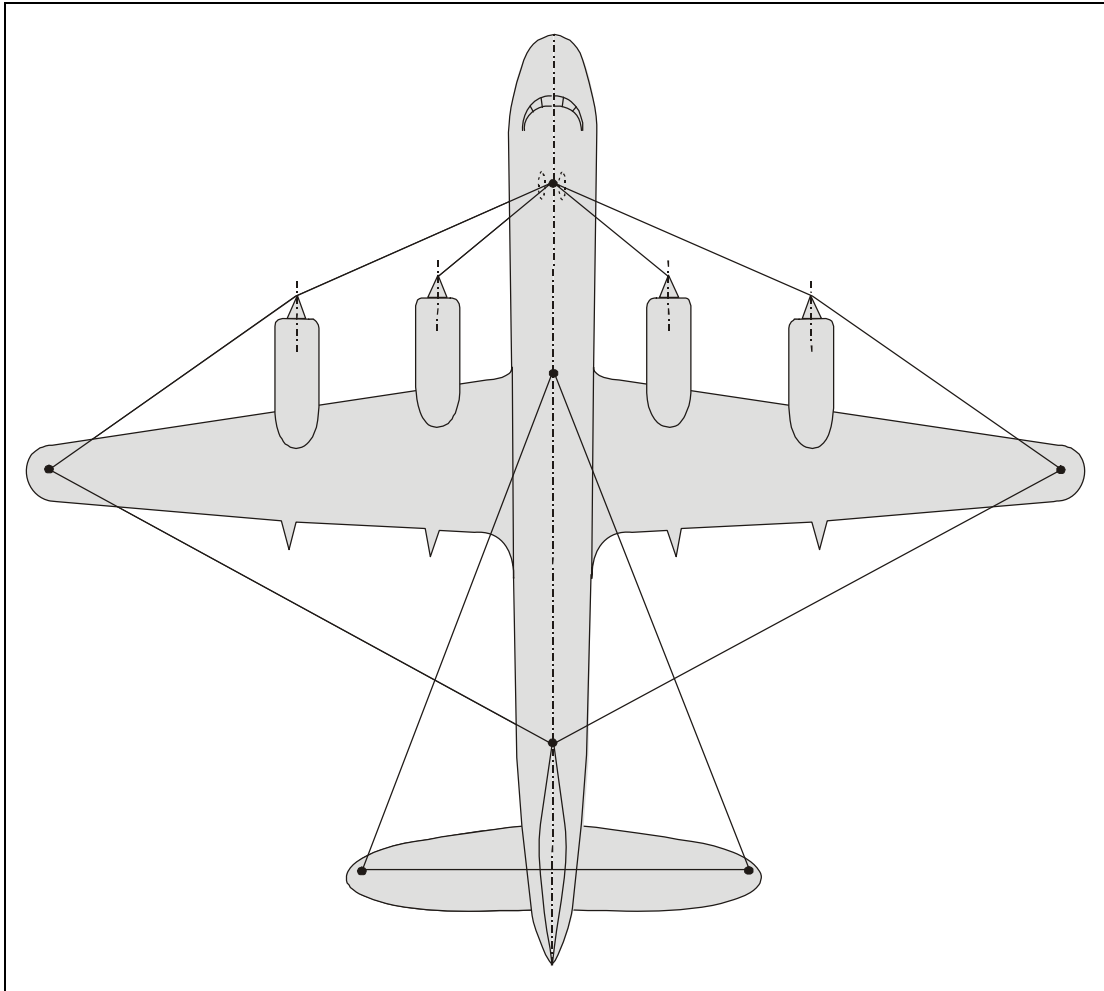

Figure 5 Symmetry Check

3.4 Rigging Checks on Biplanes

In general the rigging checks applicable to single-engined biplanes during reassembly after overhaul are as follows, but specific requirements relating to a particular type of aircraft should be ascertained from the relevant approved manual. The use of rigging boards, etc., is described in paragraph 3.3, as are other checks (such as the symmetry check) which are not peculiar to biplanes.

- 3.4.1 The fuselage should be levelled laterally and longitudinally as described in paragraph 2. The centre-section should be placed on suitable trestles and the centre-section struts and wires (complete with fork-ends) attached.

NOTE: It is important that the fork-ends should be screwed the same number of turns on each end of the wire to provide for subsequent adjustment.

- 3.4.2 The centre-section should be erected onto the fuselage and the stagger (paragraph 5.7) and lateral symmetry checked. The stagger should be checked by dropping plumb bobs from the leading edge of the upper portion of the centre-section (or other defined position) and measuring the distance from the plumb bobs to the leading

edge of the lower portion of the centre-section (or other defined position). If necessary, the stagger can be adjusted by means of the front centre-section struts on most aircraft of this type. The symmetry about the centre line should be checked by measuring from plumb bobs to the sides of the fuselage and can be adjusted, if necessary, by means of the bracing wires.

NOTE: It is essential that the centre-section rigging checks should be accurately carried out, since small errors in the centre-section bracing can result in large errors in the general rigging.

- 3.4.3 The port (or starboard) top main plane should be attached to the centre-section, care being taken to ensure that the main plane is adequately supported during the assembly. The landing wires (see paragraph 5.4) should then be attached to the centre-section, the port (or starboard) lower main plane attached to the centre-section, the interplane struts, flying wires (paragraph 5.3) and incidence wires (see paragraph 5.6) fitted and the whole assembly lightly tensioned up. The completed side of the aircraft should be steadied with a trestle whilst the opposite side is assembled in the same order.

NOTE: Although usually of similar appearance, front and rear interplane struts are usually of slightly different lengths to compensate for wing contour, thus it is important to ensure that the correct strut has been fitted in the correct position.

- 3.4.4 After assembly the fuselage level should be re-checked and adjusted as necessary, after which the main planes should be trued-up by adjustments to the appropriate wires, the aim being to achieve the correct dihedral first and then to work the incidence and stagger together. Care must be taken during rigging to ensure that the main flying and landing wires are not over-tensioned to the extent of bowing the main plane spars or interplane struts.

NOTE: The specified lengths and permitted tolerances applicable to all wires are given in the rigging diagrams appropriate to the aircraft type, but the actual figures to which the aircraft had previously been rigged is recorded in the aircraft log book. If using the same components it is advisable to re-rig to the log book figures, since these may have been determined specifically to counteract a flying fault.

- 3.4.5 After the rigging of the main planes has been completed, it should be ensured that all fork-ends, etc., are in safety, are not 'butting' against the ends of the fitting and have been correctly locked, that the wires are in streamline and that anti-chafing discs and spreader bars are correctly fitted to prevent vibration of the wires.

3.4.6 **Empennage**

The empennage should be attached in accordance with the instructions contained in the relevant manual and adjusted (where this is possible) to within the limits specified in the relevant rigging diagram. It should be noted that the tailplane struts are usually handed and, unless these are correctly positioned, the fairings will not be in line of flight.

NOTE: Tailplanes provided with an adjustment mechanism must be set to the neutral position before checking is commenced.

3.4.7 **Twin-Engine Biplanes**

The general procedure for rigging twin-engined biplanes is basically similar to that described above for single-engined biplanes but it must be ensured that the weight of the engines is taken up on the appropriate struts before completing the general rigging.

3.5 Checking Rigging with Sighting Rods

This method of checking rigging is used mainly on the larger types of aircraft and consists basically of sighting with a theodolite the positions of datum marks on a series of rods of graduated lengths, each of which is inserted into a specified jugged position on the underside of the aircraft.

3.5.1 For the initial check, the aircraft should be brought to the rigging position (see paragraph 2) and the sighting rods inserted at the appropriate stations.

NOTE: Since any rod can be fitted into any socket, it is important to ensure that the rods are inserted in their correct positions.

3.5.2 A theodolite, erected at an appropriate distance and position from the aircraft should be levelled up with the datum mark on the master sighting rod (usually the shortest rod fitted under the fuselage) and then readings should be taken from this sighting line at each rod station and recorded. A typical method of taking the readings is illustrated in Figure 6.

NOTES: 1) A method which provides accurate vertical adjustment and rigidity for a theodolite is to mount it on a hydraulic jack.

2) It may not be possible in every instance to obtain a reading on every sighting rod from one theodolite position, in which case the theodolite should be appropriately repositioned, realigned on the master rod and the check continued in the same manner as before.

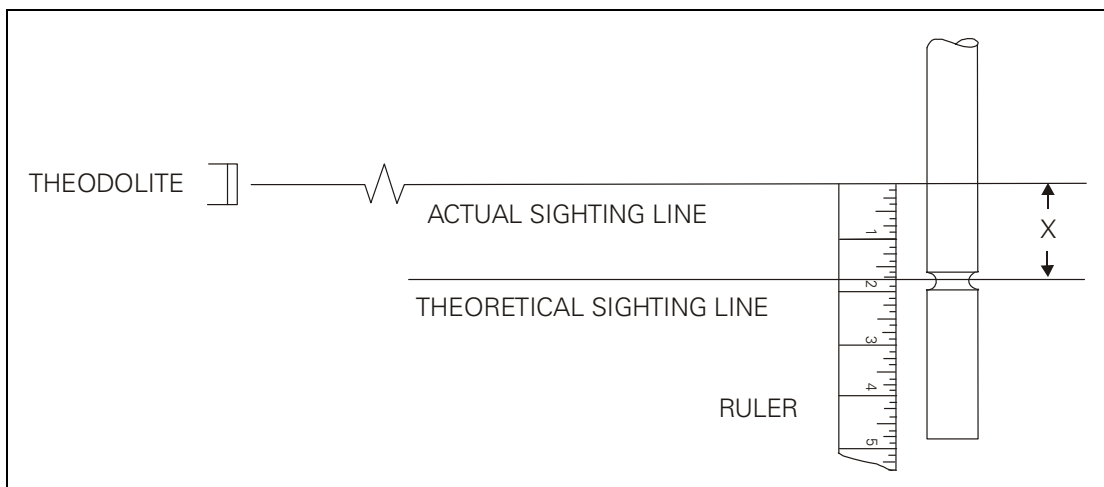

Figure 6 Typical Method of Taking Readings

3.5.3 The readings thus obtained must be within the tolerances permitted by the manufacturer (details of which are usually included in the rigging drawing) and entered in the aircraft log book for permanent record.

3.5.4 There are two basic methods applicable to the use of sighting rods and these are described below.

a) On some types of aircraft the sockets into which the sighting rods are inserted are adjustable in the vertical direction so that once variations from nominal figures have been recorded, the rods can be 'zeroed' and permanently locked. Thus the sighting line on all subsequent checks should in fact coincide with the datum marks on all the rods if the rigging is correct. Rods used for this method have the single datum as illustrated in Figure 6.

- b) The second method is to use sighting rods on which are marked the datum line, on either side of which is also marked graduations indicating the permissible tolerance on the nominal figure in increments of 1/4 degrees. With this method the sockets into which the rods are inserted are not adjustable and subsequent readings should give the actual figures recorded on the initial check.

NOTE: When rods of the 'screw-in' type are used it should be ensured that they are fully screwed home before the check is commenced.

- 3.5.5 When a component (e.g. wing or tailplane) is changed, it will be necessary to again carry out the initial check to ascertain actual figures.

4 Lowering the Aircraft

Before any attempt is made to lower the aircraft to the ground it must be ensured that wing supports and any other equipment which might foul and damage the aircraft are moved clear. The aircraft should be lowered evenly and, when the aircraft weight is accepted on the undercarriage, the jacks should be further lowered to ensure that they can be removed without fouling the aircraft structure.

5 Definitions

- 5.1 **Anedral.** An inclination outwards and downwards relative to the lateral datum.
- 5.2 **Dihedral.** The angle (or angles) at which the wings and tailplanes are inclined outward and upward relative to the lateral datum.
- 5.3 **Flying Wires.** Wires the principal function of which is to transfer the lift of the main planes to the main structure. These wires are sometimes termed 'lift wires'.
- 5.4 **Landing Wires.** Wires which brace the main plane against forces opposite in direction to the direction of lift, as occur, for example, in landing. These wires are sometimes termed 'anti-lift wires'.
- 5.5 **Incidence.** The angle between the chord line of the wing or tailplane and the longitudinal datum.
- 5.6 **Incidence Wires.** Wires bracing the main plane structure in the plane of a pair of front and rear struts.
- 5.7 **Stagger.** The distance between the leading edge of the lower plane and the projection of the leading edge of the upper plane on the chord of the lower plane.

INTENTIONALLY LEFT BLANK

Leaflet 51-130 The Effect of Disturbed Airflow on Aeroplane Behaviour

1 Introduction

- 1.1 This Leaflet gives general guidance on the cause and effect of disturbed airflow on aeroplane behaviour, with particular reference to high-performance aeroplanes. It emphasises the need for special care in the preservation of correct airframe contours because of the serious effect on aeroplane behaviour, particularly at high speeds, of seemingly trivial discontinuities in contour, profile, etc.
- 1.2 It is important that the point of transition from laminar to turbulent airflow on aerofoil surfaces occurs at the position intended in the design. At high subsonic speeds the transition point may be designed to be effective at a position some 30 to 50% along the wing chord from the leading edge and can be very sensitive to even small protuberances or discontinuities on the wing surface.
- 1.3 Faulty contours can have dangerous effects on an aeroplane flying at or near the stalling speed, whilst rough surfaces, badly fitting joints, gaps, etc., will adversely affect, to some extent, performance in all regimes of flight. However, defects which may be considered of minor importance to low-speed aeroplanes may have a considerable influence on aeroplanes flying at higher speeds. For example, the behaviour of the airflow over an aileron can be seriously affected by those departures from design which influence the position of the transition point, thus affecting the response, or the rate of response, of the aeroplane, the trim and the drag.
- 1.4 No attempt is made in this Leaflet to describe any aerodynamic principle or theory; any description or illustration given is solely to help clarify the 'cause and effect' of the defect and is not considered to be a formal aerodynamic representation.
- 1.5 Since the methods used to determine the causes of flying faults (and the methods of rectification) vary considerably with different types of aeroplanes, it is essential that the manufacturer's instructions, as specified in the relevant manuals, should be carefully followed.
- 1.6 Guidance on the general rigging of aeroplanes is given in Leaflet 51-120 and on the inspection of aeroplanes after heavy landings or abnormal flight loads in Leaflet 51-70.

2 General

In high performance aeroplanes the surfaces subjected to airflow are manufactured to within relatively close contour and gap limits and these limits have to be maintained if increased drag and other penalties are to be avoided. In this connection, the most critical areas of the aeroplane, where high accuracy in manufacture and the greatest care in maintenance are involved, include the leading edges of wings, tailplane and flying control surfaces, shrouds and trailing edges, engine intakes and static-vent areas. However, it should be noted that production tolerances are normally permitted and thus it should never be necessary to adjust any dimension to give an accuracy greater than that required by design solely for the purpose of maintaining performance standards.

- 2.1 Modern high performance aeroplanes are so manufactured that the original smoothness of contour is maintained more effectively than in previous generations of aeroplanes (e.g. by the use of machined skin panels). Nevertheless, small

departures from the prescribed alignment and contours can occur during service and may be very difficult to recognise. Although such irregularities may have a negligible effect at lower speeds, changes of trim may occur as the aeroplane reaches its limiting Mach number.

NOTE: Although an aeroplane may be flying at subsonic speed, it is not unusual for the airflow over certain sections to be at transonic or supersonic speed.

- 2.2 Apart from changes of attitude and trim which may or may not occur due to departures from the original aerodynamic contours (e.g. malalignment of control surfaces, incorrect fitting of inspection panels, fairings and cowlings, dents or wrinkles in wing skins, protruding bolt heads, etc.), such defects will also cause an increase in drag, resulting in a deterioration in aeroplane performance and range. For long-distance flights the results could be a marked increase in fuel consumption and seriously reduced fuel reserves.
- 2.3 In addition to defects which may be 'built in' as described in paragraph 2.2, it should be borne in mind that fairings and other fittings which are insecurely attached, might distort in flight, with similar results.
- 2.4 In summing up, it can be said that anything which disturbs the normal smooth airflow over an aerodynamic surface will have an adverse effect on the handling and performance of the aeroplane. However, if such adverse effects are reported, the full range of ground-set trim adjustments should be utilised before a search is made for the less obvious profile defects.

3 Defects

For the purpose of this Leaflet, it is assumed that the more common control faults, such as mechanical stiffness, jerkiness of controls, excessive play, etc., have been dealt with and that servo motors, cable tensions, spring struts, rigging limits, etc., are satisfactory.

3.1 Engine Cowlings and Fairings

The correctness of the fit of engine cowlings and fairings is important and must be within drawing tolerances, since, for example, if excessive airflow enters inside the cowlings, considerable pressure build-up may occur and drag may result (see also paragraph 3.4.2). The gaps between the edges of cowlings and fairings should be within design limits (see Figure 1) and no overlap should be permitted unless this is the design intention. It is essential that any rubbing strips or seals onto which the cowlings or fairings bed, should be in good condition.

- 3.1.1 The contours of cowlings and fairings should be maintained in the design condition, since dents, bent corners or protruding attachment bolts or other securing devices will affect the flow of air over the component. It should also be ensured that the cowlings and fairings are so adjusted and locked that they cannot move or vibrate in flight as a result of aerodynamic loads.
- 3.1.2 The contours of turbine engine air-intake ducts are of particular importance, since dents or damage to the lips of the ducts or the skin inside will interfere with the smooth airflow to the engine, with a resultant loss in performance and an increase in fuel consumption. In some cases such defects have resulted in rough running of the engine because of uneven distribution of air to the compressor and, in other cases, in inefficient operation of the engine cooling system.

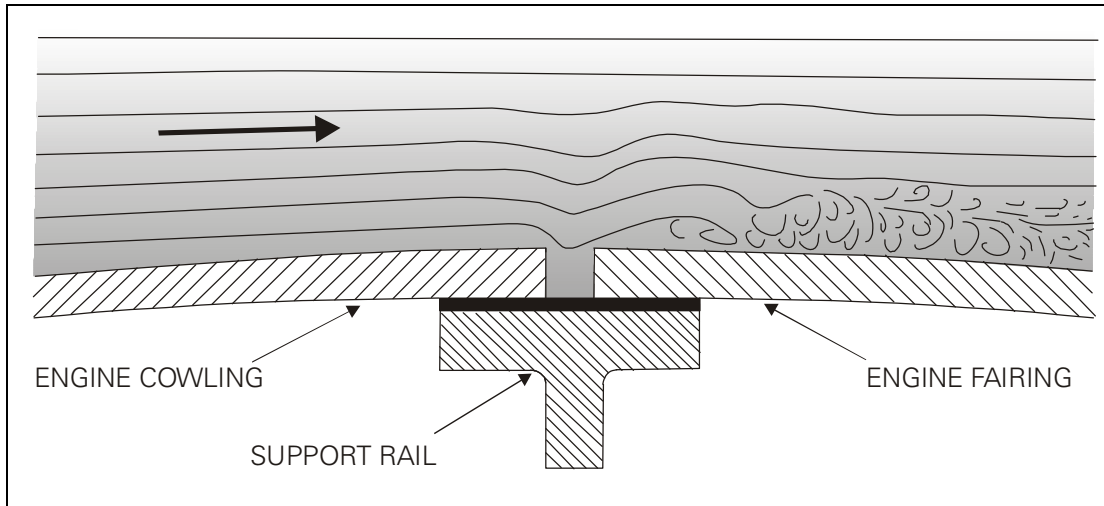

Figure 1 Drag Due to Gap in Cowlings

- 3.1.3 Cowlings and fairings should be stored and handled with care (see also paragraph 4.4). Attachment devices, locating dowels and fittings should be checked for looseness resulting from strain, wear, etc. Toggle fasteners should be correctly adjusted to give the required 'over-centre' loading and the associated fairings should be a good flush fit.

3.2 Fuselage

Cabin pressure leaks can cause a severe disturbance to the smooth flow of air along the fuselage and will create a considerable increase in drag. It should be ensured that cabin pressurisation seals at entrance doors, emergency hatches, clear-vision panels, etc., provide a complete and effective seal. The effect of such a defect is illustrated in Figure 2.

- 3.2.1 Entrance doors, hatches, etc., should be carefully checked for alignment with the fuselage skin, with the fuselage pressurised where appropriate, since if any wear has occurred to the latches, locks, rails or hinges, it may permit the door, hatch, etc., to protrude beyond the normal fuselage contour, creating a disturbance to the airflow.
- 3.2.2 It should be noted that the effect of pressurisation leaks, malalignment of aerodynamic contours, etc., is particularly detrimental towards the forward end of the fuselage and special care should therefore be given to the fit of windscreens, glazing strips, crew entrance doors, nose fairings and radomes.

3.3 Wings

The smoothness and contour of the wing surfaces, especially the top surfaces, is of the utmost importance if increased drag is to be avoided and the lateral trim of the aeroplane is to remain unaffected throughout the speed range.

- 3.3.1 It is necessary, for example, on aeroplanes fitted with fuel filler caps designed to be flush with the top surface of the wing, to ensure that the cap is fitted properly and not protruding above the wing contour; this is particularly important, for example, after fitting new sealing washers.

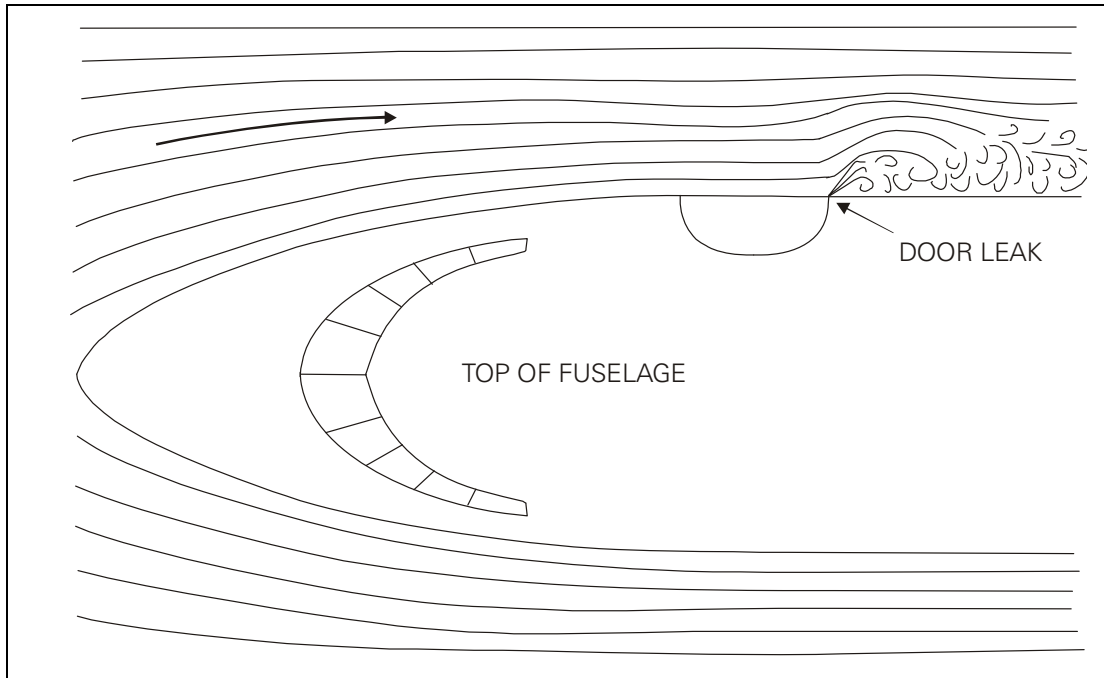

Figure 2 Pressure Leak from Fuselage

- 3.3.2 Even small irregularities such as those caused by protruding rivet or bolt heads, badly replaced screws in panels, stepped or gapped panel joints, convexity and concavity or ripples in the wing skin which may not be obvious during normal inspection, must not be ignored, since all can result in a break in the smoothness of the airflow over the wing.
- 3.3.3 An important factor from the point of view of high Mach number performance, is waviness and this is most important near the leading edges of lifting surfaces. Waviness can cause early shock-wave effects, which result in increased drag and a lower buffet boundary.
- 3.3.4 On aeroplanes which carry dinghies or life-rafts in wing stowages, the fit of the stowage cover is of paramount importance in maintaining the design airflow over the wing. The fit of the cover with the surrounding skin contour must be maintained within permitted tolerances. Correct fit may be obtained by adjustment of the cover retaining attachments, but can also be affected by the weather-seal around the interior of the cover.
- 3.3.5 The wing tip is also an important part of a wing and should be examined for surface condition. Detachable wing tips should also be examined to ensure that the chord line and rigging are satisfactory.
- 3.3.6 To ensure freedom from defects such as those described in 3.3.1 to 3.3.5, some manufacturers of high speed aeroplanes provide contour jigs or templates with which to check the wing surfaces, including the leading edges, shrouds and trailing edges. Such jigs should be used with considerable care and in accordance with the manufacturer's instructions; any departures from contour in excess of permitted limits should be rectified.
- 3.3.7 When jigs are not available, a rough check for contour defects may, in some cases, be made by running the fingers around the suspected surfaces, since this may reveal irregularities in surface finish which may not otherwise be perceptible. It is also sometimes helpful in the detection of more obvious defects, such as skin dents,

malalignment of shrouds and ailerons, etc., when jigs are not available, to stretch a thin cord across the wing, from the leading edge to the trailing edge and parallel to the line of flight and to check as indicated in Figure 3.

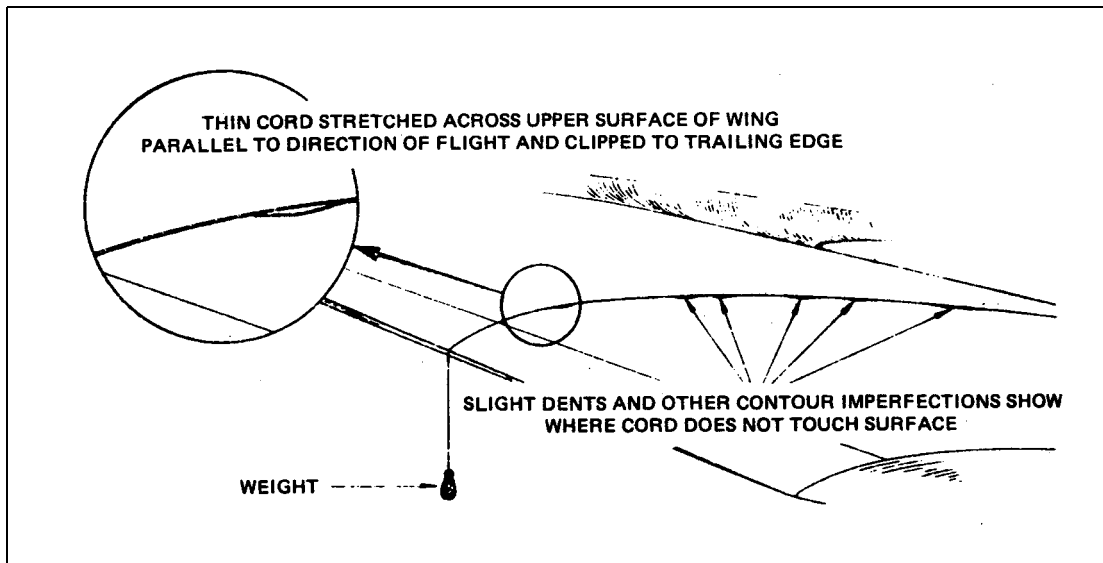

Figure 3 Checking Contours

- 3.3.8 It is sometimes possible to make a rough check on the more obvious types of defects by locking all the flying controls in the neutral position and then standing aft of the aircraft as shown in Figure 4. This may reveal distortion or damage to the trailing edges of the wings, flying controls and shrouds, which may sometimes be caused by accidental contact with ground equipment.
- a) By slightly altering their position (up or down) the observer can make a rough check on the control surfaces and the rear of the wing surfaces. This is mainly done to check access points, tank doors, rear edges of cowlings, etc., to ensure that they blend into the natural contours of the aerofoil surfaces.
- 3.3.9 A check similar to that outlined in paragraph 3.3.8 can be made from a position forward of the wing, in order to check the contour of the wings and tailplane, with special emphasis on the leading edges, since defects in these areas are particularly critical.

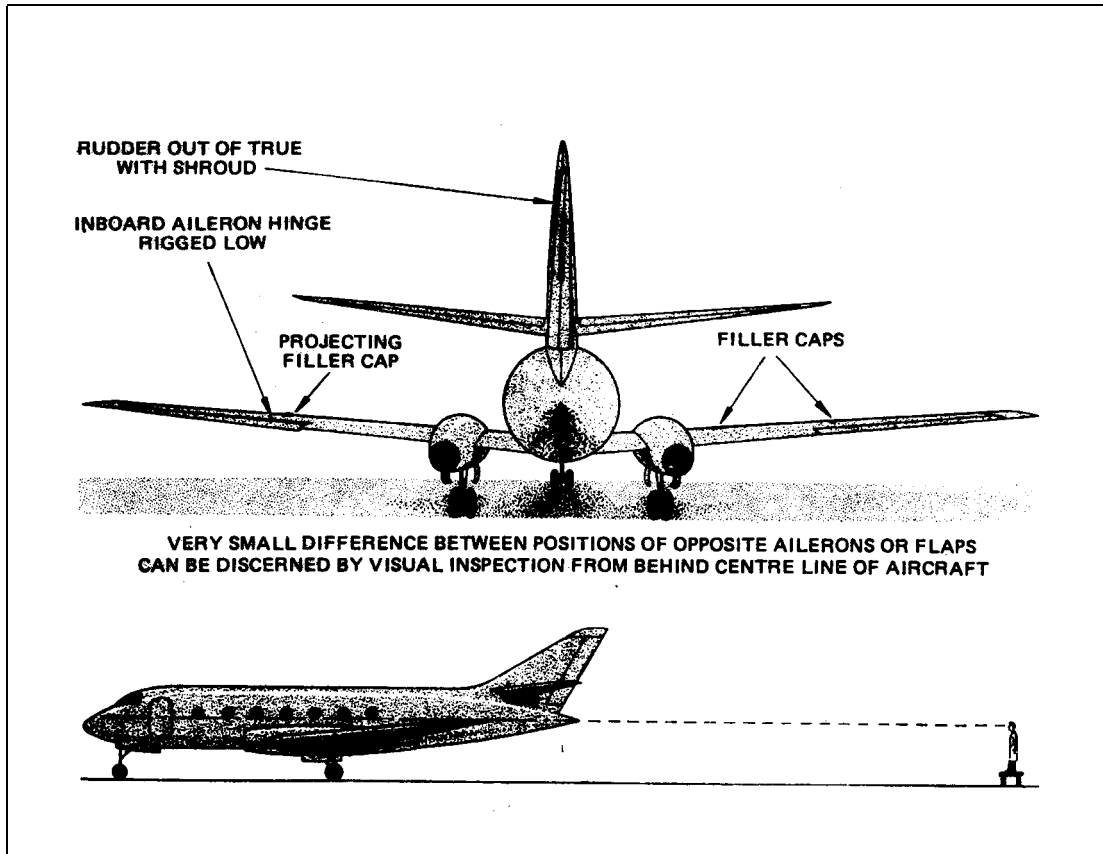

Figure 4 Checking by Observation

3.4 Landing Gear Doors and Fairings

Landing gear doors and fairings are often the cause of considerable drag and should, therefore, be carefully inspected in the retracted position for fit, contour and sealing. In addition, such components may be subjected to high aerodynamic loads and the possibility exists that badly fitting or ineffectively secured panels could become detached from the aeroplane, with serious results. Where such components are subjected to high aerodynamic loads the rigging procedures normally incorporate a degree of pre-loading to counter the effect of air loading.

- 3.4.1 In some cases it may be found necessary to simulate aerodynamic loads by loading the doors with weights or by use of a spring balance. This practice would indicate any excessive play or backlash in the mechanical linkage. In mechanically-actuated door operating systems, this check would be sufficient to ensure against sag in flight, but when the door operating system is completely or partially hydraulically operated, subsequent sag in flight may depend on the efficiency of the hydraulic system. In the latter case every effort should be made to ensure that the relevant part of the hydraulic system is free from both internal and external leaks.
- 3.4.2 A landing gear door, fairing or seal which is in any way badly fitting when the door is closed may allow air to enter the landing gear bay and eventually escape at the aft end of the door or fairing, creating considerable drag. In this case drag is caused by the fact that the air leaking into the cavity loses speed and then has to be speeded up again as it leaks out at the other side. Figure 5 illustrates the more serious case of flow breakaway as a result of leakage, but even if this does not occur, the drag penalty may still be quite high.

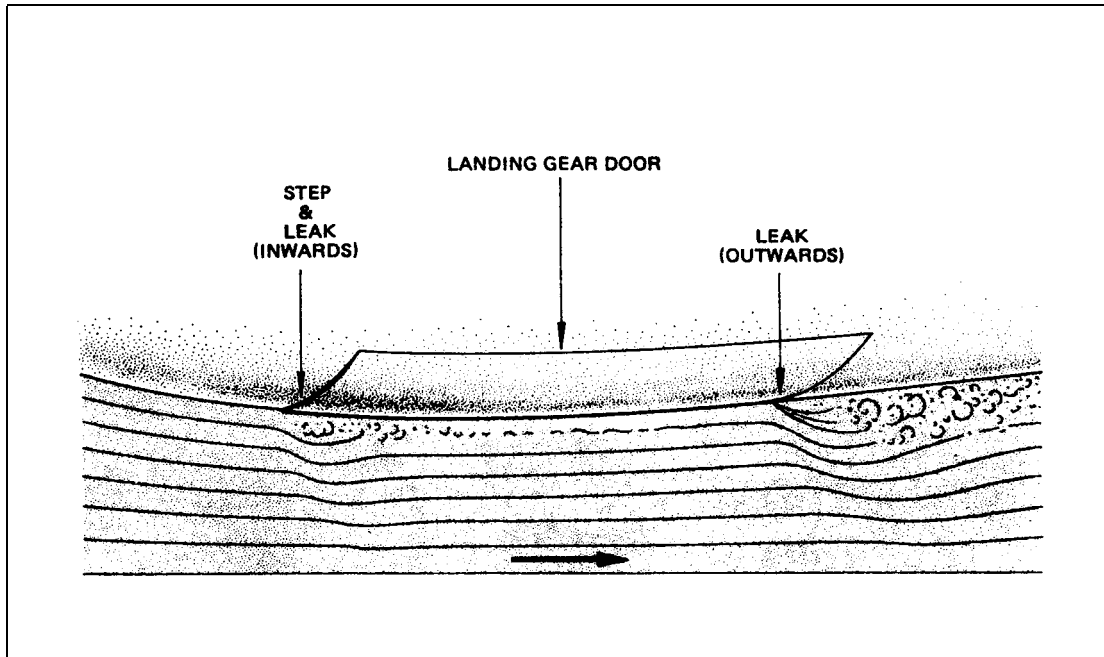

Figure 5 Leaks at Landing Gear Door

3.5 Flaps

The undersurface of the flaps should be examined for damage caused by debris thrown up during take-off and landing and flap shrouds should be checked for security, damage and distortion. The flaps should also be checked for sagging when in the 'up' position. In the case of flaps which employ slots for improved efficiency it should be ensured that the correct gaps are maintained.

3.6 Aileron Shrouds

The clearances between ailerons and aileron shrouds are very critical and must be checked carefully. The shrouds should be rigid and free of any form of damage on both bottom and top surfaces and care must be taken to ensure that no distortion of the shroud, or the wing skin immediately in front of the shroud has occurred, since this could upset the airflow over the aileron in a manner similar to that illustrated in Figure 6.

3.7 Movable Leading Edge Devices

Movable leading edge devices should be checked in the retracted position to ensure that they conform to the contour of the main wing, particularly on the upper surface. The condition of any seals in the leading edge should also be checked, to ensure that there is no air leakage from the lower to the upper surface. The leading edge devices should also be checked in the extended position to ensure that the correct gap is maintained between the devices and the wing.

3.8 Airbrakes/Spoilers

Airbrakes and spoilers should be checked to ensure that they are a flush fit when retracted. Where spoilers are used for lateral control, they should be checked to ensure that the 'dwell' before spoiler extension with control displacement is correct.

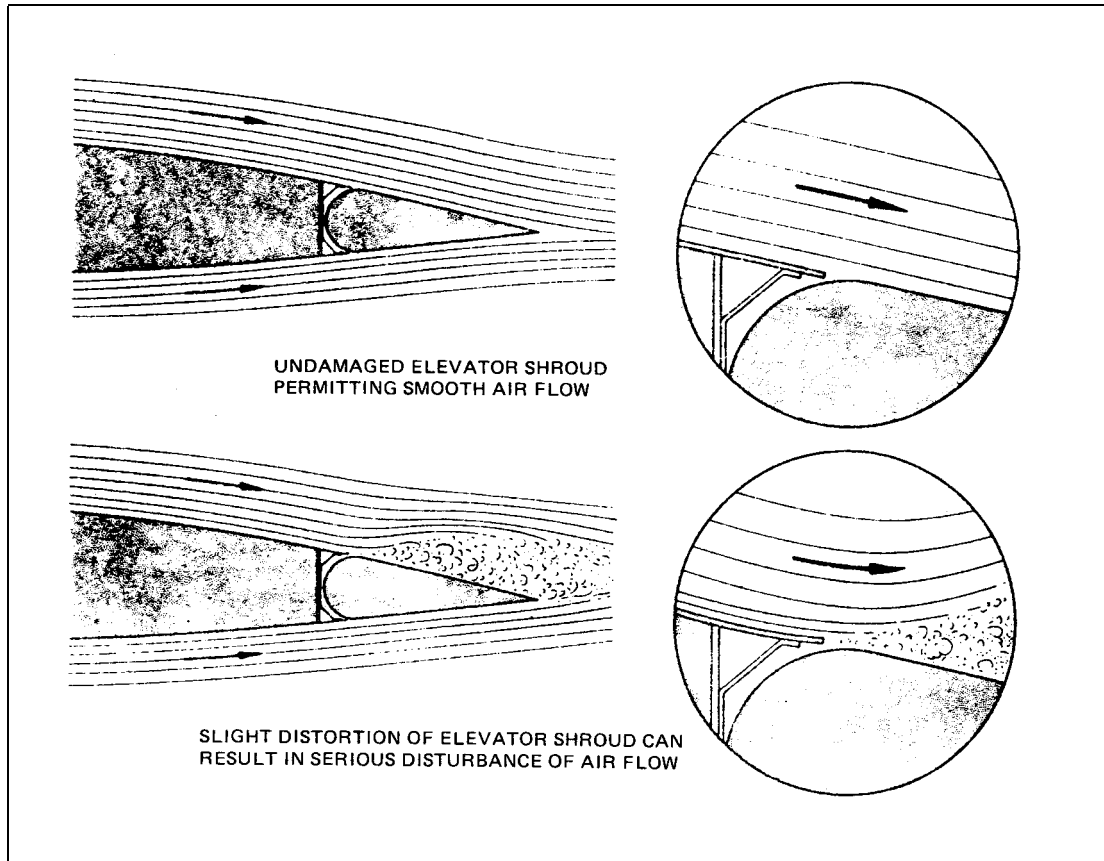

Figure 6 Airflow Over Elevator

3.9 Vortex Generators

A check should be made to ensure that vortex generators are not bent or distorted and that none is missing.

3.10 Wing Fences

Wing fences should be checked for alignment and, in addition, the condition of any seals between the fence and the wing should be carefully checked.

3.11 Tail Unit

Care should be taken to ensure that any fillets between the tailplane and fin and the fin and fuselage, are in good condition and free from dents and other damage.

- a) The leading edges and surfaces of the tailplane and elevators should be checked for damage caused by debris thrown up during engine run, take-off and landing.
- b) Particular care should be paid to the alignment and clearance of rudder and elevator shrouds, since these can become very critical at speeds approaching Mach 1. Slight distortion of tailplane shrouds or excessive clearances can create a breakaway of the airflow over the elevator surfaces at high speeds which can result in little or no response to elevator control inputs. As these conditions would generally occur only at speeds approaching the limiting Mach number for the aeroplane concerned, it should be assumed that the lack of elevator response might occur in a dive when a dangerous condition could result. The airflow which occurs over the elevators is illustrated in Figure 6.

4 Precautions During Maintenance

To ensure as far as possible against damage to aeroplane surfaces during maintenance, the precautions outlined in the following paragraphs are recommended as the minimum necessary.

- 4.1 When working on the top surfaces of aeroplanes, precautions should be taken to avoid damage to the surface by scratching, etc. and suitable mats or protective coverings, as detailed in the appropriate manual, should always be placed in position before work is commenced.
- 4.2 Ladders or trestles should never be rested against any part of the aeroplane and fuelling hoses should not be dragged over flying control surfaces, wing leading or trailing edges, etc.
- 4.3 When removing inspection covers, panels, cowlings, fairings, etc., they should never be levered off, since this may damage and distort them. Leverage should not be applied when securing or unlocking fasteners, since this may strain the fasteners to such an extent that the associated panel could become loose.
- 4.4 Cowlings, fairings, etc., should never be placed directly onto concrete floors. It is recommended that suitable racks should be provided onto which the cowlings can be placed immediately after removal from the aeroplane.
- 4.5 When a panel, fairing, etc., is removed, it should be checked to ensure that the condition of any rubber moulding or sealing strip is satisfactory.
- 4.6 In certain wet take-off conditions followed by freezing, the landing gear door seals may sustain damage as a result of icing and these should be checked for any such damage.
- 4.7 On aeroplanes having painted surfaces, it is essential that the thickness of the paint coating, particularly at leading edges, should be carefully controlled, since the amount of paint on the top side of a leading edge can easily influence the trim of an aircraft. This is particularly important where fillers are used to restore leading edge contours and the finished work should always be checked with a contour jig.
- 4.8 All surfaces should be kept clean, since dirt, oil or mud will always adversely affect the performance of the aeroplane.
- 4.9 When changing control surfaces or other aerofoil components, care should be taken to ensure that the new components fitted are in correct aerodynamic alignment with the surrounding structure, since the slight differences which can occur in nominally similar components, as a result of manufacturing tolerances, could affect the trim or performance of the aeroplane.

INTENTIONALLY LEFT BLANK

Leaflet 51-140 Paint Finishing of Metal Aircraft

1 Introduction

The purpose of this Leaflet is to provide guidance and advice on the application of paint to metal aircraft and aircraft parts. The treatment of wooden structures is described in Leaflet 51-150, and the doping of fabric-covered aircraft is described in Leaflet 51-160. The term 'paint' is used in a general sense and includes primers, varnishes, lacquers and enamels. CAP 747 Mandatory Requirements for Airworthiness, Generic Requirement (GR) No. 10, Painting of Aircraft, should also be read in conjunction with this Leaflet.

- 1.1 The primary reason for applying paint to an aircraft, is to protect the skin and structure from corrosion. Paint does this by excluding the atmosphere and liquids and by providing a supply of chromate in the primer, which leaches out in the presence of moisture and inhibits corrosive action on the metal surface. The top coat of paint provides an abrasion and fluid resisting cover to the primer and also the decorative finish.
- 1.2 The various paint schemes used, may be in accordance with British Standards or DTD specifications, or may be specially prepared by the manufacturer. No single scheme would be satisfactory for use on all parts of an aircraft, because of the particular requirements for the different areas and for the different metals to be treated. For example, engines are subjected to heat, and require the use of a heat-resistant paint; skin and structure in the lower fuselage may be in contact with condensation and spilled corrosive fluids, and may require more protection than other areas; magnesium always requires special treatment.
- 1.3 The effectiveness of a paint scheme depends on the proper preparation of the surface, the maintenance of suitable conditions in the paint shop and the application of the paint in accordance with the relevant specifications.

2 Painting Materials

A paint scheme is broadly classified according to the type of material used in the finishing coats, but the undercoat or primer and, where applicable, the filler coats, may be manufactured from different materials. The various types of primers and finishing coats are discussed in the following paragraphs.

2.1 Primers

The main purpose of a primer coat is to provide adhesion to the metal surface. There are four main types of primers – synthetic, stoving, etch and epoxy – with wide variations within each type.

- 2.1.1 Synthetic and stoving primers are very similar, and are usually derived from resins and fatty acids. They are pigmented with chromates and produce a thick coating, but their resistance to fluids used in modern aircraft is not particularly good.
- 2.1.2 Etch primers contain resin, chromate, solvent, and phosphoric acid, and have very good adhesion on untreated sheet metals. Etch primers can often be applied directly to aluminium without any pre-treatment other than cleaning, but some sheet metals possess a surface to which the adhesion of etch primers may be unsatisfactory; such surfaces should be given an etching pre-treatment prior to application of the etch primer.

- 2.1.3 Epoxy primers are twin-pack materials (i.e. the two ingredients must be mixed before use) and often consist of an amine cured epoxy resin, with strontium chromate as an inhibitor. They have a very good resistance to fluids used in modern aircraft and may also be used for stoving. They are generally used where maximum resistance to corrosion is required.

2.2 Finishes

There are many different types of finishes used on aircraft, the main types being cellulose, synthetic, stoving enamel, acrylic, epoxy and polyurethane. Other materials may be used in small areas where a particular property, such as resistance to battery acid, is required.

- 2.2.1 Cellulose and synthetic finishes were widely used in the past, mainly because they are easily applied, polished, and repaired. Cellulose nitrate is used as a tautening dope on aircraft fabric coverings and is also used, to a certain extent, on wooden and metal aircraft. Synthetic finishing schemes such as BS X 28, are often used as an alternative to cellulose schemes on metal aircraft. As the thinners, primer and filler used in some synthetic finishing schemes are not always compatible with cellulose materials, care must be taken to use only the approved materials. Both cellulose and synthetic finishes have good adhesion and weathering properties, but are not usually resistant to fluids used in modern aircraft.
- 2.2.2 Stoving enamels generally have a high resistance to abrasion, and are used for powerplant and airframe components which are not adversely affected by the stoving temperature. Stoving temperature is normally below 125°C (257°F), and does not have any deleterious effect on aluminium alloys, although stoving must be carried out at an early stage of manufacture, before the inclusion of heat-sensitive parts. One stoving scheme (DTD 56D) calls for one or two coats of enamel to be stoved separately, without use of a primer, whilst with another scheme (BS X 31), a primer coat is used, which may be allowed to air dry and then both primer and top coats are stoved together.
- 2.2.3 Acrylic paint for use on aircraft, is usually developed from methyl methacrylate. This paint has good resistance to high temperatures, but has poor resistance to fluids; it is rapid drying and is a single-pack material.
- 2.2.4 Epoxy paint relies on a chemical reaction for curing, and is supplied in twin-pack form. It produces a hard glossy surface, and is resistant to aircraft fluids and acids. Its weathering properties are rather poor from the appearance point of view, and it tends to 'chalk' quickly.
- 2.2.5 Polyurethane paint is generally derived from polyester and di-isocyanate and is supplied in twin-pack form. It dries to a hard glossy finish and has exceptional weathering properties and resistance to organic fluids. One drawback to the use of polyurethane is its toxicity during spraying.
- 2.3 Whilst most painting materials are manufactured to meet DTD or BS specifications, individual manufacturers usually vary the chemical compositions to suit their own particular purposes and although a number of paints may satisfy the requirements of a specification they may not be compatible with one another. Paints supplied by different manufacturers should not, therefore, be used in the same paint scheme, unless they are proved to be compatible.

3 Surface Preparation

Paint and primer are rarely applied directly to a metal surface which has not received some form of anti-corrosive treatment, or surface preparation designed to assist adhesion of the paint. The type of pre-treatment applied depends on the type of metal and on the corrosive conditions likely to be encountered in service. DEF STAN 03-2/1 describes the methods which may be used for the cleaning and preparation of metal surfaces prior to painting. These methods, which are briefly described in the following paragraphs, consist essentially of de-greasing, followed by a pre-treatment such as chromating, etching, anodising and cadmium plating.

3.1 De-greasing

All new metal should be thoroughly de-greased, preferably using trichloroethylene, unless the metal is known to be adversely affected by chlorinated solvents. A liquid or vapour de-greasing bath may be used for small items and heavily contaminated parts may be scrubbed with liquid solvent. Where an item is too large for de-greasing in a bath, its surface should be washed with rags dipped in solvent. It is important to use clean rags, and frequent changes of solvent, to prevent the spreading of contamination from one area to another.

NOTE: Trichloroethylene should not be used for hand cleaning, particularly in poorly ventilated areas, because of the health hazard to the operator.

3.2 Aluminium

Aluminium and its alloys should be anodised, or chemically pre-treated, using an approved etching or filming process.

- 3.2.1 Anodising is a process by which a thin film of oxide is formed on a surface by electrolysis. Anodising is often used on aluminium parts, since it is also a method of crack detection. Initially the anodic film is porous and readily absorbs dirt and grease, but after a few days the film hardens, and provides a poor surface for paint to adhere to; thus it is important that the surface is primed as soon as possible after anodising.
- 3.2.2 A chromic/sulphuric acid etching treatment which may be applied to unanodised surfaces prior to painting, is described in DEF STAN 03-2/1. Other etching treatments, which are approved under DTD 900, are also available. The parts to be treated are usually immersed in a bath containing the specified pre-treatment chemicals at a pre-determined concentration. After immersion for a time governed by the particular process, the parts are removed and thoroughly washed in water.
- 3.2.3 A useful combined cleaning and pre-treatment agent, which complies with DTD 900 specification, is available for use on assembled aircraft and parts. This agent is in the form of a paste which, when applied to the surface, removes corrosion products and grease, and also etches the surface. All traces of the paste must be washed off with water, using a brush to remove it from skin joints and rivet heads. After the surface has dried, it is usually given a filming treatment.
- 3.2.4 A number of filming pre-treatment processes are approved to DTD 900 specifications and these are generally simple chemical processes, which may be applied by dipping, spraying or brushing. A filming treatment provides a chromate rich film on the surface, which gives good protection from corrosion and good paint adhesion; this treatment is particularly useful for repair work. On some aircraft surfaces, subsequent painting is unnecessary.

3.3 **Magnesium**

Magnesium rich alloys are very prone to corrosion and should be treated in accordance with DTD 911C. The treatment consists of dipping the parts in one of several types of chromating baths and is usually followed by a surface sealing process. One method used by a particular aircraft manufacturer consists of an epoxy primer applied over the chromate film, followed by a nylon coating process, but other approved methods may be used.

3.4 **Titanium**

Titanium alloys have very good resistance to corrosion and do not require any special surface preparation. Solvent cleaning may be used, but care must be taken to ensure that the solvent will not cause hydrogen embrittlement or stress corrosion (see DEF STAN 03–2/1). When titanium is to be painted, an etch primer is normally used.

3.5 **Steel**

Non-stainless steels are generally cadmium plated, but a phosphate dip or spray process is sometimes used instead. Where paint is to be applied directly to the steel, the surface to be painted should be mechanically cleaned by abrasive blasting or scouring. Stainless steels are not usually painted, but if they are, an etch primer should be used after cleaning.

3.6 **Glass Fibre**

Before glass fibre is painted, all traces of parting agent should be removed. Warm water will remove water soluble agents, but white spirit or methyl-ethyl-ketone (MEK) should be used for other types. The surface to be painted should then be rubbed down with fine emery cloth and the dust removed using a lint-free cloth soaked in white spirit or MEK. An epoxy primer is generally used, the first coat being brushed on, to fill any pinholes which may be present.

3.7 **General Precautions**

Pre-treatment materials, solvents and their vapours, may have a deleterious effect on many components and materials used in an aircraft. Individual items can generally be treated away from parts which are liable to be affected, but when assemblies and complete aircraft are to be painted, precautions must be taken to prevent these liquids and vapours from coming into contact with any parts which are liable to be affected by them. All such parts, such as bearings, vents, drains, sealant, transparencies, aerials and insulators, must be masked, with plugs or adhesive tape and non-absorbent paper. Any parts in the area which do not require treatment should also be covered up, to guard against the effects of splashes, overspray and vapour. Masking material and plugs must be removed after the completion of painting.

3.7.1 Chemically pre-treated metal surfaces should, where possible, be primed immediately after the pre-treatment is completed, so as to avoid any risk of contamination. This procedure may be difficult to follow when a complete aircraft is being painted externally and the use of a suitable covering is recommended. The surface should be covered after pre-treatment, and progressively uncovered as the primer is applied.

3.7.2 All traces of aqueous washes containing acids or alkalies should be thoroughly washed off, since their residues may affect the adhesion of the paint. Water used for washing or rinsing the surface after cleaning, pre-treatment, or 'flattening', should be blown off with clean oil-free compressed air, and drops of water should be prevented from drying on the surface.

- 3.7.3 When bare metal components are solvent-de-greased, the temperature of the surface may fall as a result of evaporation. In such instances the components should be allowed to stabilise at ambient temperature before painting is commenced.

4 Painting Schemes

Apart from commercial considerations, the paint schemes applied to a particular aircraft will depend mainly on the corrosive fluids likely to be encountered. The aircraft manufacturer may specify schemes of his own, but often the schemes will be devised by the paint manufacturer and approved under DTD or BS specifications.

- 4.1 A painting scheme will normally contain full details concerning pre-treatment, materials to use, extent of thinning required, paint viscosity, and methods of application.
- 4.2 Pre-treatment, cleaning and painting involve a number of operations and provision must be made to ensure that all specified operations, including previously carried out repairs and inspections, have been checked and certified by an inspector. Evidence that a particular operation has been carried out may not always be visually apparent and could well be covered up by a subsequent operation.
- 4.3 The general procedures and precautions which should be taken when painting aircraft or aircraft parts, are outlined in paragraphs 5 to 12.

5 Painting Conditions

The evaporation of solvents and the presence of spray dust, necessitate draught-free ventilation in paint shops. The temperature should, generally, be maintained between 15°C (60°F) and 25°C (77°F) and the humidity should be kept below 75%. However, some paints require closer control of the temperature; for example, DTD 5555 requires epoxy materials to be applied at a temperature above 18°C (65°F). In addition, for the application of etch primers, the humidity should not be less than 30%.

- 5.1 Ventilation may be provided by extractor fans and filtered air inlets, but the most satisfactory method of maintaining the required conditions is by filtering and cooling the incoming air to a sufficiently low temperature to remove excess moisture, then re-heating the air before passing it to the paint shop. The air conditioning system should be capable of changing the air in the paint shop every two minutes and it is recommended that the paint shop should be kept at a slight positive pressure in order to prevent dust and draughts from entering through doors and windows.
- 5.2 The temperature and humidity should be checked at frequent intervals. A wet and dry bulb hygrometer is normally used for this purpose, the dry bulb indicating the actual temperature and the difference between the dry and wet bulb readings being used, in conjunction with appropriate tables (Leaflet 51-160), to determine the humidity.
- 5.3 Cleanliness is essential to a good standard of paint finishing. Paint shop floors should be painted or sealed to prevent 'dusting' and should be swept at the end of each day so that the air is free from dust and contamination the following morning. Dried paint and spray dust present a serious fire hazard and these should be removed at least once per week. When the paint shop is also used for pre-treatment and flattening, floor drainage should also be provided, so that rinsing water can be quickly removed and the floor can be dried before painting is commenced. Clean and dirty rags should be stored in separate bins.

- 5.4 The surface to be painted must be adequately illuminated and portable flameproof lamps may be necessary when painting the undersurfaces of wings and fuselage. The provision of good scaffolding or working platforms will be necessary with large aircraft, so that the paint can be correctly applied (see paragraph 7).
- 5.5 When ideal painting conditions are not available, e.g. when it is necessary to paint in an open hangar, a reasonable paint finish may be obtained by observing a few simple precautions.
- a) Freedom from dust, draughts and condensation must be ensured.
 - b) The item to be painted must be allowed to assume room temperature and should be slightly warmed, if necessary, to prevent condensation.
 - c) Care must be taken to prevent the surface being handled after it has been cleaned.
 - d) All parts adjacent to the item to be painted which might be affected by the painting operation should be masked or covered with dust sheets.
- 5.5.1 Precautions must also be taken to prevent the possibility of fire, by removing naked lights and arcing electrical equipment; suitable fire-extinguishing equipment must be readily available.

5.6 **Regulations**

Because of the flammability of the materials used in painting, a number of laws and by-laws have been issued relating to the handling, storage and use of paints, particularly for cellulose and other low flash point materials generally. Reference should be made to the Cellulose Solution Regulations, The Petroleum Act, the General Sections of the Factories Acts, and any relevant local bylaws, for particulars regarding these materials, and the types of equipment to be used in paint shops.

6 **Paint Preparation**

6.1 **Stirring**

Solid particles in a pigmented paint tend to settle whilst the paint is left standing and even when no sediment is apparent, the paint may vary in consistency from top to bottom. In order to ensure that consistent results are obtained all paints, except glossy varnishes and lacquers, should be thoroughly stirred before use. The top of the can should be wiped clean before the lid is opened and if a skin has formed on the paint, this should be removed by running a knife round the inside of the tin and lifting the skin out completely.

- 6.1.1 Mechanical stirring is preferable to hand stirring and when the amount of work justifies it, a mechanical agitator or tumbler should be used.
- 6.1.2 For hand stirring, a flat bladed non-ferrous metal paddle should be used. This may be used with a spiral lifting action to circulate the solid particles throughout the paint.
- 6.1.3 When the sediment is hard and difficult to disperse, the upper liquid should be poured into a separate container and the sediment should then be stirred to a smooth paste, after this the poured-off liquid should be added gradually, until it is all returned to the original container.

6.2 **Thinning**

Paint manufacturers normally recommend the amount of thinners to be added to a paint, depending on the method of application. This basic mixture will often need to be adjusted to suit local conditions. To ensure satisfactory and consistent results,

some manufacturers recommend that the viscosity of the thinned paint should be checked before application, by the use of ISO flow cups (see BS 3900 Part A6).

6.3 **Straining**

In many cases, paint manufacturers recommend that paint should be strained before use, to remove any extraneous matter which may have been picked up after the can is opened. Metal gauze of 60–120 mesh is the most suitable filter for this purpose, but paper or lint-free cloth or muslin may also be used. Metal gauze should be cleaned in solvent immediately after use, but other types of filters should be discarded. The paint should be allowed to flow through the filter and not worked through with a brush. Some manufacturers recommend that all filters used with epoxy materials should be discarded after use, to avoid subsequent contamination.

6.4 **Twin-pack Materials**

Before mixing twin-pack materials, each of the constituents should be stirred separately. If thinning is required, only the approved thinner should be used; the proportions of the activator and base material must not be altered in an attempt to correct the viscosity. To avoid wastage, the amount mixed at any one time should be limited to the amount which can be used within the pot-life period. After mixing, the paint should be strained, then allowed to stand for a specified period before use, so that entrapped air may escape.

7 **Methods of Application**

There are numerous methods of applying paint to a metal surface, including spraying, dipping, brushing and rolling. Exterior surfaces are generally sprayed. Small components may be sprayed, dipped or brushed.

7.1 **Conventional Spray**

This is the method used for the application of the majority of aircraft paints. It is a convenient, fast and easily controlled method of application, which gives consistent results. The main disadvantage of this method is that the overspray may become a nuisance when other work is being carried out in the area. For small areas the use of spray guns with integral paint containers is satisfactory, but for larger areas pressure feed equipment is generally recommended.

7.2 **Airless Spray**

This method is particularly suitable for applying polyurethane paint, with which spray dust in the atmosphere must be kept to a minimum for health reasons. Since no air is used in atomising the paint, atmospheric pollution is minimised. The spraying equipment is however more expensive and the thickness of the paint film is difficult to control. Many paints cannot be applied by this method, either because their viscosity is unsuitable, or because their pigments are too coarse to pass through the spray orifice.

7.3 **Dipping**

This method can only be used with single-pack materials, since twin-pack materials have a limited pot life. When dipping is used, the smallest dip tank consistent with the size of the work should be used, and the viscosity of the paint should be checked frequently. Straining and stirring of paint used for dipping is most important and the best method of stirring is by pump circulation, in which the paint is filtered before it is returned to the tank. Where small tanks are used, hand stirring should be carried out frequently and the paint should be drained off and strained at appropriate

intervals. Dip tanks should be provided with lids, in order to minimise contamination and evaporation of solvents when the tank is not in use.

7.4 **Brushing**

Brushing should only be used for small repairs and for surfaces and corners which are not accessible for spraying.

7.5 **Rolling**

Where an open surface has to be painted and other work is being carried out in the vicinity, use of a hand roller may be recommended. However, this method results in a thick layer of paint thus adding to the weight of the finish and spraying is generally preferred.

8 Paint Spraying

Prior to the commencement of spraying, the effects of the paint on surrounding structure, aerals, sealants, sealed bearings, joints and grease nipples must be considered and precautions must be taken to shield these parts if this has not already been done prior to pre-treatment (paragraph 3.7). Identification plates and windows should be blanked with greaseproof paper and masking tape, or with paper and soft soap and any open pipes or intakes which are not to be painted should be suitably protected.

8.1 The paint should be applied as an even, wet coat, which will flow out smoothly. Spray dust and inadequate coverage will result from spraying too lightly and 'runs' or 'sags' will result from spraying too heavily.

8.2 For conventional spraying, the air pressure at the spray gun should be maintained at 2.75 to 5.5 Bar (40 to 80 lbf/in²), to produce a satisfactory spray. When pressure feed equipment is used the air pressure at the container should be varied according to the viscosity of the paint, so that the paint reaches the gun in a gentle continuous flow; generally, a pressure of between 0.3 to 1.03 Bar (5 to 15 lbf/in²) should be used. For airless spraying, the pressures recommended by the equipment manufacturer should be used. In all cases allowance should be made for the loss of pressure between the gauge and gun, and some manufacturers provide tables showing the pressure drop which can be expected with hoses of various diameters and lengths.

8.3 A spray gun should be adjusted to give the required spray pattern (generally fan shaped for normal painting, and circular for 'spotting in'), and its operation should be checked briefly on scrap material. The gun should be held 15 to 25 cm (6 to 10 in) from, and at right angles to, the surface being painted, and each stroke should follow the contour of the surface. Each stroke of the gun should be straight and the trigger should be released at the end of each sweep, the speed of movement being regulated to deposit an even wet coat. Each successive stroke of the gun should overlap the previous stroke, to keep a wet paint film and to provide an even overall coating.

8.4 When the paint scheme requires a number of coats to be applied, or a filler coat to be flattened, the drying times specified by the paint manufacturer should be observed. After flattening, the surface should be washed-off and allowed to dry before the next coat is applied.

8.5 **Care of Equipment**

8.5.1 Spray guns should be thoroughly cleaned immediately after use, using the solvent appropriate to the type of paint. Cleaning is particularly important after using twin-

pack paints, since once these have cured they are very difficult to remove. It is recommended that, where possible, a spray gun is set aside solely for use with twin-pack materials. A gun should be cleaned by firstly flushing it through with solvent and then partially stripping it in order to remove any residual paint; stiff bristle or nylon brushes should be used for cleaning areas which are difficult to get at. The gun should not be immersed in solvent, since this would remove lubricant from the working parts and glands.

- 8.5.2 Paint hoses in pressure feed and airless spray systems should also be washed out with solvent immediately after use, since once the paint has dried it could flake off and cause blockages during future use.
- 8.5.3 The air compressor should be well maintained and the air storage tank should be drained daily. Oil and water traps, and air filters, should be located adjacent to the coupling point for the spray equipment, so as to prevent contamination from the main supply and to be readily available for servicing. It is recommended that a record should be kept of all equipment servicing operations.

9 Painting Faults

Provided that the metal surface is properly cleaned and pre-treated and the paint is applied in accordance with the particular specification and the manufacturer's recommendations, the paint should adhere satisfactorily, and, when cured or dried, should not be easily removable by abrasion or washing. The main faults which can occur when applying a paint scheme to an aircraft, are described in the following paragraphs.

9.1 Lifting of Paint

Lifting of paint is usually the result of the lifting of the primer from the metal surface, and is usually first indicated by blistering, swelling, or wrinkling of the paint film. In the majority of cases this is caused by inefficient cleaning of the metal surface. This may result from the presence of corrosion under the primer. It may also be caused by incompatibility of the primer and the top coat.

9.2 Poor Adhesion

Poor adhesion may result from inadequate cleaning, pre-treatment or preparation of the paint, from application under adverse conditions or from failure to comply with the drying requirement specified for the particular scheme.

9.3 Spray Mottle

Sometimes known as 'orange peel' or 'pebble', spray mottle may be caused by incorrect paint viscosity, air pressure, spray gun setting or the distance the gun is held from the work.

9.4 Spray Dust

Spray dust is caused by the atomised particles of paint drying before reaching the surface being painted. The usual causes are excessive air pressure, the gun held too far from the surface, or incorrect gun setting.

9.5 Runs and Sags

Runs and sags result from too much paint being applied, so that the film of paint falls under its own weight before drying. The faults may be caused by over-thinning of the paint, incorrect adjustment of the gun and occasionally, by inadequate surface preparation.

9.6 Blushing

This is a fault most commonly experienced with cellulose materials and appears as a 'clouding' or 'blooming' of the paint film. It may be caused by moisture in the air supply, excessive humidity, draughts, or sudden changes of temperature. The use of 'anti-chill' thinners is recommended when conditions are such that blushing can be expected. Blushing can often be removed by softening the paint surface with thinners and drying in a warm, dry atmosphere.

10 Paint Repairs

After an aircraft has been in use for some time, the paintwork ages and hardens and accumulates a layer of dirt, grease and polish, which may be very difficult to remove. In addition, greases and lubricants may contaminate the paint and be absorbed into crevices, sealing strips, soundproofing and furnishings. When it becomes necessary to repair chipped or blemished paintwork, to re-paint part of an aircraft after repairs have been carried out, or to apply new paint over the existing paintwork (e.g. lettering, stencilled instructions and crests), these contaminants must be removed in order to obtain satisfactory adhesion of the new paint.

10.1 Parts of an assembly which may be adversely affected by the materials used in re-painting and parts not needing to be re-painted, should be blanked or masked (see also paragraph 3.7). Any absorbent material adjacent to the areas to be re-painted should, where possible, be removed to prevent contamination; where removal is not practicable, the part should be thoroughly de-greased and dried before painting is commenced.

10.2 When an area is re-painted after the removal of corrosion, or after repairs have been carried out, all debris, swarf, globules of sealant and oil or dye penetrant which may have been used for non-destructive testing, should be cleaned off.

10.3 All loosely-adhering or chipped paint should be removed from the area to be re-painted using paint stripper or aluminium wire wool and the area should be thoroughly cleaned with solvent to remove any contamination. Several applications of solvent may be required to remove contamination from older paintwork. The area should then be wet 'flatted' with fine emery cloth, to roughen the paint, to form a feathered edge where paint has been removed, and to remove pre-treatment from bare areas. Residues should then be removed, by washing and by use of a brush in seams and crevices. The area should then be thoroughly dried, and allowed to assume room temperature before painting.

- NOTES:**
- 1) When emery cloth is used for rubbing down, care must be taken to avoid damage to clad or plated surfaces, and to exposed joints incorporating sealant and structural adhesives.
 - 2) When glass fibre surfaces are being prepared for re-painting, they must be thoroughly roughened in order to ensure adhesion of the paint.

10.4 When painting over existing paintwork and when applying lettering, crests, or stencilled instructions, the compatibility of the new paint with the original paint should be checked. The surface to be painted should be lightly wiped over with a clean cloth moistened with the thinners appropriate to the paint to be applied; a reaction such as wrinkling or blistering of the old paint will indicate incompatibility, but light removal of pigment from the paint will indicate that the new paint is compatible and that the cleaning operation was satisfactory.

- 10.5 After the surface to be painted has been cleaned and prepared, the original paint scheme should be restored and any dry spray edges should be polished to blend in with the existing paintwork. Materials, drying times and painting precautions, should be the same as those specified for the original paint scheme, except that if a filler coat is used it must be of the same material as the top coat. For example, the original filler may have been synthetic and the top coat cellulose, but for the repair both filler and top coat must be cellulose.
- 10.6 Any masking or plugs which have been fitted must be removed after the paint has dried.

11 Paint Stripping

When re-finishing an aircraft, it is usual to strip back the paint to the bare metal and to re-apply the desired paint scheme. The ease with which the paint can be removed depends on the paint type, its thickness and its age, but approved proprietary paint strippers are available, which are specially prepared for removing particular types of paint. Epoxy and polyurethane paints are the most difficult to remove.

- 11.1 Some paint strippers may have an adverse effect upon structural bonding adhesives, some may affect the adhesives used for the attachment of sealing and chafing strips and others may result in hydrogen embrittlement of high strength structural steel parts. Only the approved paint stripper should be used and precautions should be taken to prevent its contact with susceptible materials, by masking or plugging. An inspection should be carried out after stripping, to ensure that these precautions were effective. Vents and drains should also be plugged, to prevent the entry of paint stripper, washing water and paint particles.
- 11.2 The paint stripper should be applied freely to the surface of the paint, and left until the paint has softened; the paint can then be removed with a wooden scraper. Residues should be washed off with water and care should be taken to remove all paint and paint remover from seams and crevices, using a short-bristled nylon brush. When the paint is particularly thick it may be necessary to apply the paint stripper a second time after the initial softened coat has been removed. The removal of debris after stripping is most important, since the softened paint could harden in piano wire hinges, control rod bearings and other moving parts, and present a serious hazard. After the surface has been washed, it should be wiped with a rag soaked in solvent, to remove the final traces of paint.
- 11.3 Some paint schemes involve the use of an epoxy primer, followed by an air-drying synthetic or acrylic finish, and, provided that the primer is in a satisfactory condition, the top coat can be selectively stripped, using a specially formulated paint remover. This paint remover is applied in the normal way, but a rubber scraper should be used to prevent damage to the primer. After removal of the top coat, the primer should be thoroughly washed with solvent to remove any contaminants and the finish should be re-applied.

12 Health Hazards

As stated in paragraph 5, a paint shop must be well ventilated, to remove solvents and spray dust which may present a health hazard. Solvents have an irritating effect on the skin and eyes, and may be toxic. Constant contact with solvents may dry out the skin and cause dermatitis and the use of a barrier cream is recommended. Inhalation of solvent vapours and spray dust should be avoided and a face mask should be worn in areas where concentrations may be high.

- 12.1 Polyurethane spray dust can cause chest irritation if inhaled, and this is the main reason for using an airless spray to apply this material. When polyurethane is applied by conventional spray, it is recommended that a full face mask with an independent air supply is worn.
- 12.2 When mixing twin-pack materials, care should be taken to avoid splashing the skin or eyes. If this does occur, the material must immediately be washed off with running water.
- 12.3 When using paint strippers, it is advisable to wear goggles and PVC gloves and all contact between the stripper and the skin should be avoided.
- 12.4 Requirements issued by the Health and Safety Executive (HSE) regarding the Control of Substances Hazardous to Health (COSHH) should also be addressed.

13 Storage

Paints should be kept at room temperature, in a dry store. Containers should be marked with the date of receipt and used in strict rotation; they should not be held longer than their stated storage life. Unpigmented glossy material should be disturbed as little as possible, so that any sediment may settle at the bottom of the can, but cans containing other materials should be inverted at frequent intervals, to reduce the settlement of pigments.

Leaflet 51-150 Fabric Covering

1 Introduction

The purpose of this Leaflet is to provide guidance and advice on the covering of aircraft components with fabric and on the methods employed for repairing and testing such coverings. Guidance on the application of dope to fabric is given in Leaflet 51-160.

2 General

Before the covering of any component is commenced, the structure must be inspected, all foreign matter removed and protective treatments (as prescribed in the relevant drawings) must be applied. Often it is necessary to install flying control cables, electric cables, fuel tanks and other systems before covering large components and these should be inspected as necessary and checked for security. The most suitable conditions for the application of fabric are a room temperature of 16°C to 21°C (61°F to 70°F) and a relative humidity of not more than 70%.

NOTE: Information on the method of determining relative humidity is given in Leaflet 51-160, and on the testing and inspection of textiles in British Standard F100.

3 Materials

This paragraph describes the natural-fibre materials used in the covering of British-manufactured aircraft. Foreign fabric-covered aircraft use these or similar materials manufactured in accordance with equivalent specifications. Information on the use of fabrics produced from man-made fibres for aircraft will be found in paragraph 12.

3.1 Fabrics

Aircraft fabrics are woven from spun threads or 'yarns'; those running lengthwise are termed the 'warp'; and those running crosswise are termed the 'weft'. The number of yarns per centimetre (inch) varies with different weights of fabric and is not necessarily the same in both warp and weft. The non-fraying edge of the fabric is termed the 'selvedge'.

3.1.1 When an unsupported fabric cover is required to carry air loads, unbleached linen to British Standard (BS) F1 is normally used, but some aircraft have coverings of cotton fabric complying with BS F8, BS F57, BS F116 or DTD 575A.

3.1.2 A light cotton fabric complying with BS F114 (referred to as Madapolam) is generally used for covering wooden surfaces. This acts as a key to the doping scheme, giving added strength and improving surface finish.

3.2 Tapes

Linen tapes complying with B8 F1 and cotton tapes complying with BS F8 are available in various widths for covering leading edges, trailing edges and ribs, and for repair work. The materials are supplied with serrated edges, as illustrated in Figure 2. Cotton tape complying with BS F47 (referred to as 'Egyptian tape') is generally used on those members where chafing may occur between the structure and the fabric (see also paragraph 4.1) and is also used externally to protect the fabric against damage by the stringing cord.

3.3 Thread

Linen thread complying with BS F34 is normally used. For hand sewing, No. 40 thread (minimum breaking strength 3 kg (7 lb)) used double, or No. 18 thread (minimum breaking strength 7.25 kg (16 lb)) used single, are suitable. For machine sewing, No. 30 thread (minimum breaking strength 4.5 kg (10 lb)) or No. 40 thread is used.

3.4 Stringing

Flax cordage complying with BS F35 or braided nylon cord (coreless) complying with DTD 5620 is normally used.

3.5 Eyeleted Fuselage Webbing

On a number of older types of aircraft, cotton webbing braid with hooks, or lacing eyelets and kite cord, are used for securing the fuselage fabric.

3.6 Storage

All materials used for fabric covering should be stored at a temperature of about 20°C (68°F) in dry, clean conditions and away from direct sunlight. When required for use, the materials should be inspected for possible flaws (e.g. iron mould discolouration, signs of insect, rodent, or other damage) and any affected parts rejected.

4 Preparation of Structure

The structure to be covered should be inspected as outlined in paragraph 2. All corners or edges and any projections such as bolts or screw heads likely to chafe the fabric must be covered with tape. Where serious chafing may occur and a strong reinforcement is required, a canvas or leather patch may be sewn to a fabric patch, then doped into position.

4.1 In order to prevent dope from reacting with any protective treatment and to prevent fabric from adhering to wooden structure, all aerofoil members which will be in contact with the fabric are normally covered with adhesive cellulose or aluminium tape, or painted with dope-resistant white paint. Exceptions to this requirement are discussed in paragraphs 7.3, 7.4 and 12.1.

4.2 On some aircraft, which have a tubular metal fuselage frame, the fuselage shape is made up with wooden formers attached directly to the main framework and to these wooden formers are secured light longitudinal members onto which the fabric covering is doped. This secondary structure must be inspected for security and any sharp edges removed with fine glass paper.

4.3 Where stringing is likely to be chafed by parts of the structure, protection should be provided by wrapping such parts with cotton tape. Before the tape is applied the structure should be treated with varnish to protect it from corrosion should the tape become wet.

4.4 Internal controls and cables should be tightened to assume their normal positions and secured at the root rib. Their location should be noted so that stringing pitch can be selected to avoid chafing.

5 Covering Methods

An aircraft fabric may be fitted with the warp or weft running at 45° to the slipstream, or in line with the slipstream. The former (bias) method is generally considered to be stronger and more resistant to tearing, but the latter method is used on most light

aircraft. The two methods used to re-cover an aircraft are outlined in paragraphs 5.1 and 5.2, but the method used in a particular instance should follow that of the original manufacture unless otherwise approved.

5.1 Prefabricated Envelopes

A number of manufacturers produce fabric envelopes for re-covering various models of aircraft. Separate envelopes are made up from patterns for the mainplanes, fuselage, tailplane, fin and flying control surfaces and greatly simplify the task of re-covering. The envelopes are made loose enough to facilitate slipping them over the structure and to achieve the proper tautness after doping.

5.1.1 Mainplanes

The envelope is drawn over the wing tip and gradually worked down over the mainplane, generally keeping the spanwise seam in line with the trailing edge. When the cover is located it is secured (by stitching, cementing, or retaining strip) to the inboard end of the mainplane, any necessary openings for cables, struts, tank caps, etc., are cut and stringing is applied as necessary (paragraph 6).

5.1.2 Fuselage

The fin and fuselage envelopes are often supplied separately and in some cases the fuselage envelope is open, or partially open, at the bottom, to simplify fitting. The fin envelope is usually fitted first, then the fuselage envelope is stretched forwards over the fuselage and secured in the same way as the original fabric. The cover is usually cemented or doped to the fuselage formers (paragraph 4).

5.1.3 Control Surfaces

Control surface envelopes are usually left open at the hinge line, where they are secured by cementing, doping or stitching.

5.2 'Blanket' Method of Covering

With this method a bolt of fabric is used and covers are made-up on the site. Lengths of fabric, or a number of lengths joined side-by-side, being used to cover the aircraft structure.

5.2.1 Mainplanes and Tailplanes

The cover is normally made-up from lengths of fabric machine-stitched together side-by-side. This is laid round the surface, starting and finishing at the trailing edge and joined by hand stitching as shown in Figure 3. On some aircraft with light alloy structure, hand stitching is dispensed with, the cover edges being wrapped round the tip and trailing edge and doped into position. The cover is then attached to the ribs by stringing (paragraph 6).

5.2.2 Fuselage

A number of different methods are used to attach fabric to the fuselage; the more common being as described in paragraph 4.2. The fabric is not normally attached in one piece, but usually consists of several pieces (e.g. sides, top and bottom, which are doped separately onto the frame, or sewn together at their edges. Joins or seams are covered with doped-on tape. Since the air loads on the fuselage are not as great as on the mainplanes, it is not usual to employ stringing, although it may be specified in some instances.

5.2.3 Control Surfaces

These are covered in a similar way to the mainplanes and usually require stringing. The fabric is normally folded round the hinge line, since this is usually straight and sewn together round the remaining contour of the surface.

6 Seams, Stitches and Stringing

6.1 Seams

The seams in the fabric covering should be either parallel to the fore-and-aft line of the aircraft or on a bias, depending on the covering method used (paragraph 5). With the exception of trailing edge or leading edge joints (where such action cannot be avoided) seams should never be made at right angles to the direction of airflow. Two types of machined seams are employed, the balloon seam and the lap seam.

6.1.1 The Balloon Seam

The balloon seam, sometimes referred to as the 'French Fell', is normally specified for all fabric joints and is illustrated in Figure 1. To make the seam, the edges of the fabric are folded back 16 mm (0.625 in) and are then fitted into each other as shown, tacked together and then machine sewn with four stitches per centimetre (nine stitches per inch) in two parallel lines 9 mm (0.375 in) apart and 3 mm (0.125 in) from either edge. After completion, the seam should be examined over a strong electric light (preferably a light-box) to ensure that the inside edges of the fabric have not been missed during sewing.

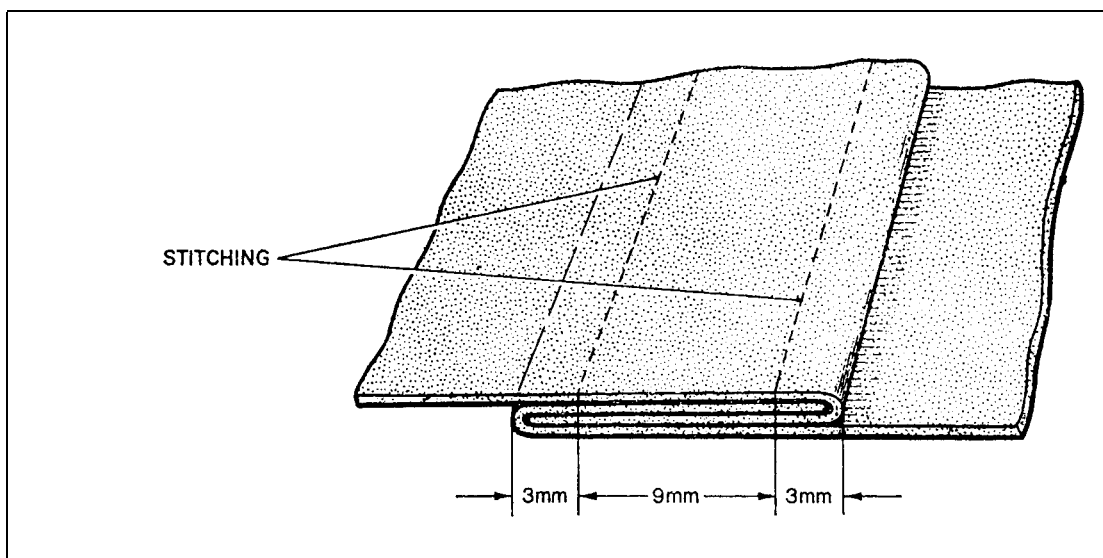

Figure 1 Balloon Seam

6.1.2 The Lap Seam

The lap seam, illustrated in Figure 2, should only be used when specified by the manufacturer. Unless the selvages are present, the edges of the fabric should be serrated with 'pinking' shears. The edges should overlap each other by 31 mm (1.25 in) and should be machine sewn with four stitches per centimetre (nine stitches per inch), the stitch lines being 12 mm (0.5 in) apart and 9 mm (0.375 in) from the edges. After stitching, a 75 mm (3 in) wide serrated-edge fabric strip should be doped in position.

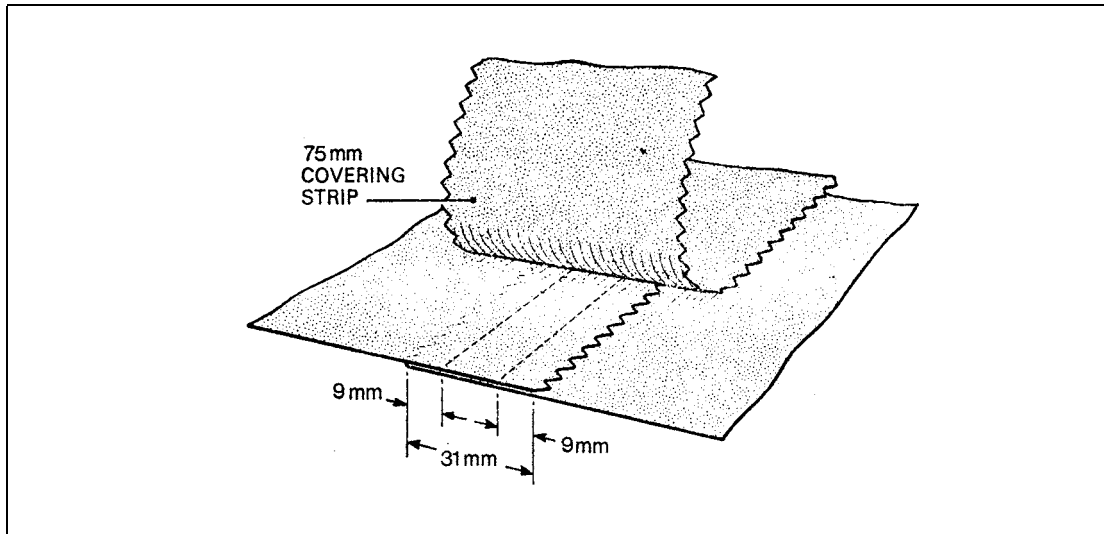

Figure 2 Lap Seam

6.2 Hand Sewing

Apart from the herring-bone stitch (Figure 9) and the boot stitch (Figure 13), which are used for repair work and are described in paragraph 10, the only other stitches used are the overhand stitch (sometimes referred to as the 'trailing-edge' stitch) and the lock stitch. The overhand stitch is used for trailing edges, wing tips, wing root ends and wherever a sudden change of section occurs.

6.2.1 Overhand Stitch

Sufficient excess fabric should be allowed for turning under before sewing is commenced; a 12 mm (0.5 in) turn-under is usually sufficient. An even gap of about 6 mm (0.25 in) (usually) should be allowed for pulling up the two edges to obtain the correct fabric tension, but this figure can only be determined finally by experience of the work in hand.

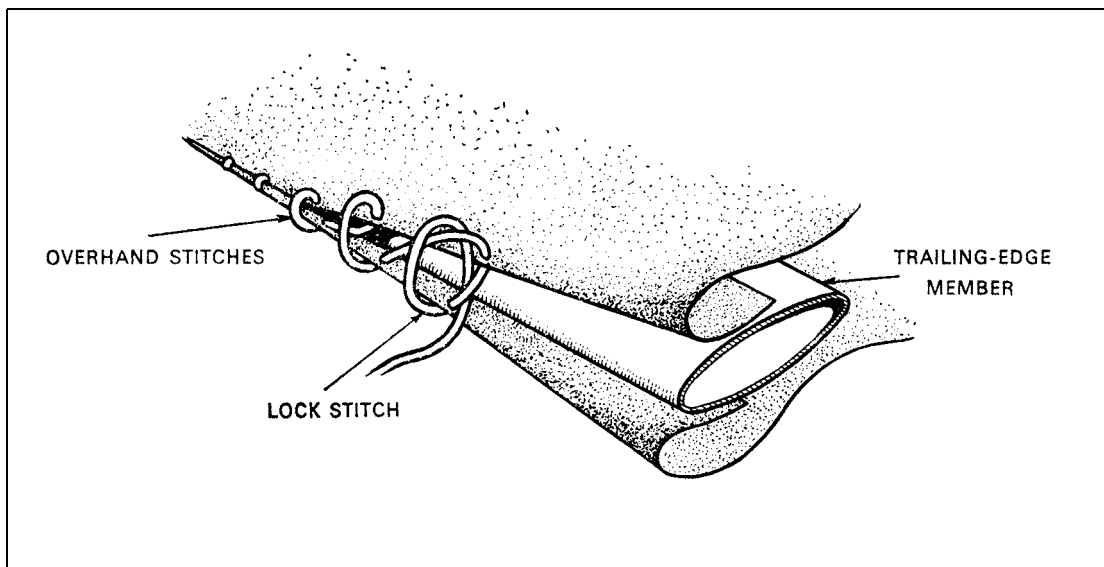

Figure 3 Overhand Stitch

6.2.2 The sewing should follow the contour of the component evenly to ensure a good finish after dopping. The number of stitches should be three per centimetre (eight per inch), a lock stitch being included approximately every 50 mm (2 in). Overhand stitching is illustrated in Figure 3, the lock stitch being shown as the last stitch before the stitching is pulled tight.

6.3 Use of Beeswax

All threads used for hand sewing and all cord used for stringing (when not pre-waxed), should be given a liberal coating of beeswax. This protects the thread, facilitates sewing and reduces the likelihood of damaging the fabric or enlarging the stitch holes.

6.4 Stringing

Flax cord complying with BS F35 is normally used for stringing purposes and is generally applied in single strands as shown in Figure 4. As an alternative, but only when approved by the manufacturer, doubled No. 18 thread may be used during repair work.

6.4.1 When the fabric covering of the component has been completed, cotton tape to BS F47 should be stretched centrally over each rib, top and bottom and stitched into position at the trailing edge.

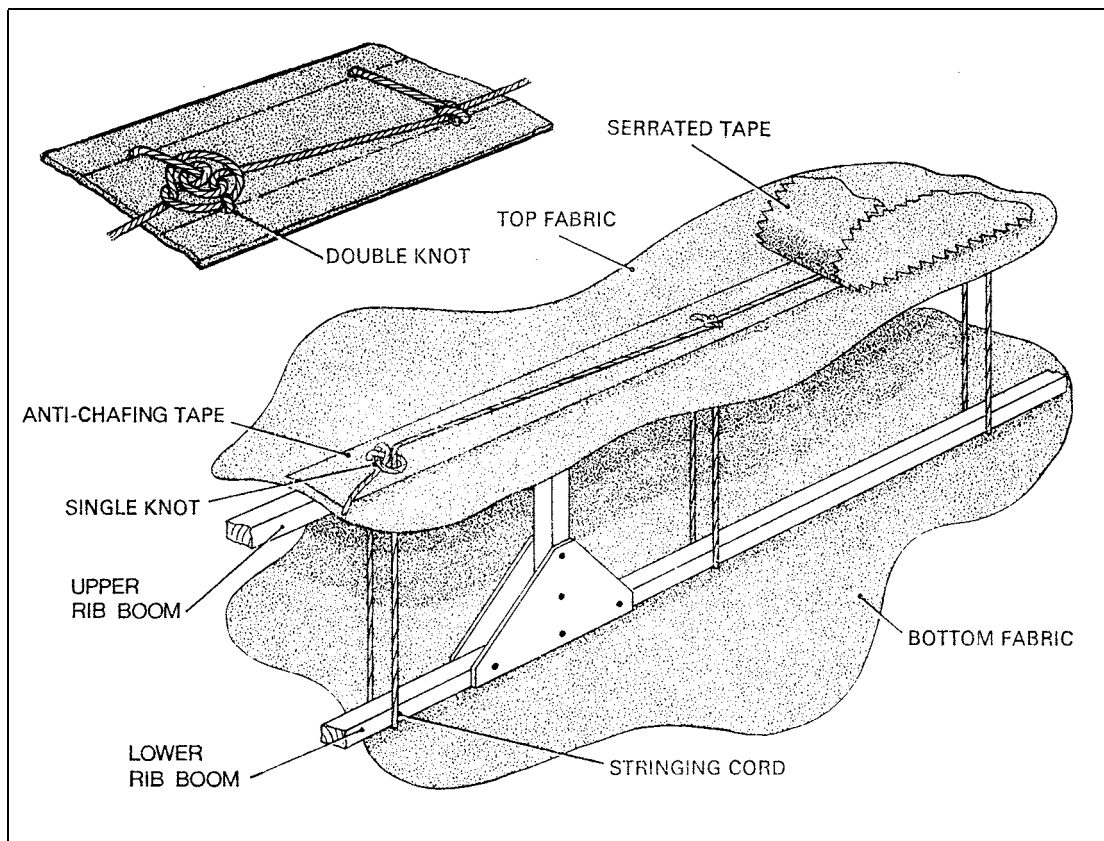

Figure 4 Typical Stringing

a) Using a stringing needle and commencing at the top surface, the stringing cord should be passed through the tape and fabric as close to the rib as possible, out through the bottom fabric and tape, round the lower rib boom and back up through both surfaces again. A double knot should be used to secure the first and last stringing loops and after each 450 mm (18 in). In between, single knots may be used.

- b) The stringing pitch is normally 75 mm (3 in) but in the slipstream area (see paragraph 6.4.4), or on aircraft of more than 910 kg (2000 lb) weight, the pitch is often reduced to 37 mm (1.5 in). Variations from these pitches will be stipulated in the relevant aircraft manuals and it may be necessary to vary the pitch in order to avoid internal structure or control runs.
- c) When the stringing has been completed a strip of serrated tape, 37 mm (1.5 in) wide, should be doped over the stringing line on both surfaces, care being taken to ensure that no air is trapped under the tape and that the tape is securely attached to the main cover.

NOTE: The knots depicted in Figure 4 are typical but a different type of knot may be specified by the manufacturer.

6.4.2 Boom Stringing

This type of stringing is used on deep aerofoil sections. The procedure is similar to that described above, except that the cord is passed round the rib boom instead of round the entire rib. Top and bottom surfaces are therefore attached separately and the inside of each boom must be taped to prevent chafing of the stringing cord. Alternate rib and boom stringing is sometimes used on aerofoils of medium depth, i.e. between 150 and 300 mm (6 and 12 in).

6.4.3 Stringing Tension

Care must be taken to ensure that all stringing is maintained at a satisfactory tension and that it is not so tight as to cause distortion of the ribs.

6.4.4 Slipstream Area

For stringing purposes, the slipstream area is considered to be the diameter of the propeller plus one rib on either side. In the case of multi-engined aircraft, the entire gap between the slipstreams, regardless of its width, is also considered to be slipstream area.

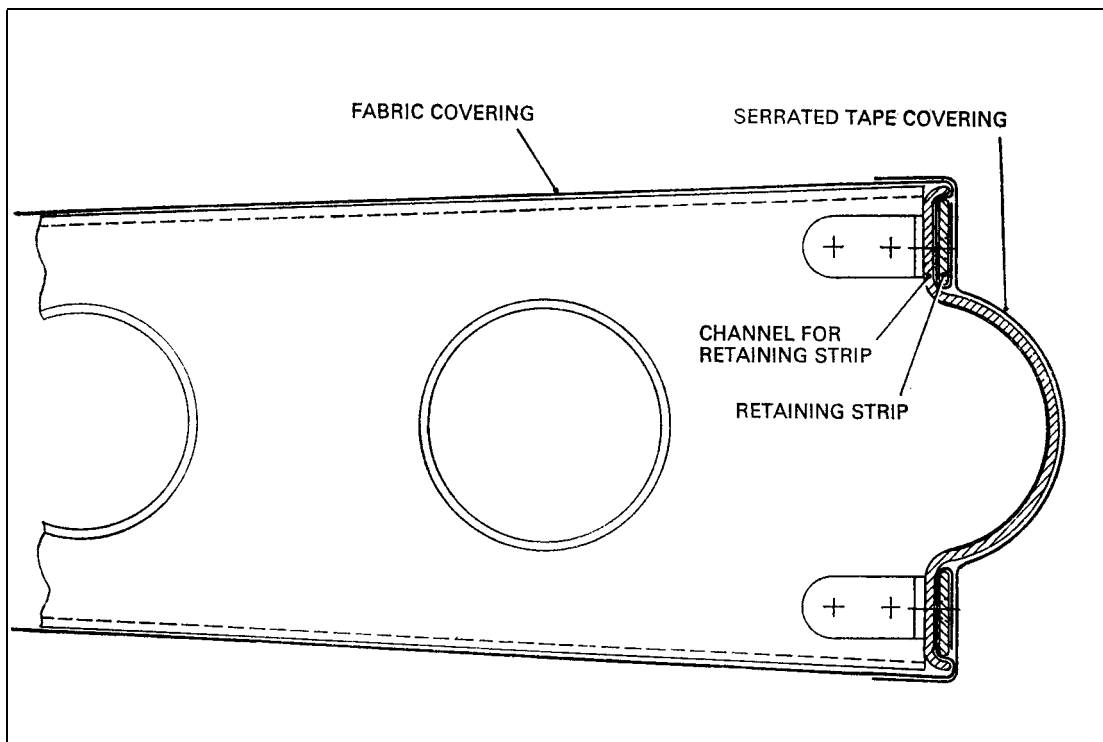

Figure 5 Attachment of Fabric by Strip

7 Miscellaneous Methods of Fabric Attachment

In addition to the standard methods of fabric attachment described in paragraph 6, other methods are sometimes employed. The most commonly used are outlined below.

7.1 Attachment by Strip

Attachment of the fabric by wrapping it around a light alloy strip or rod which is then secured in a channel or groove is sometimes used with metal structures. This method is illustrated in Figure 5.

7.2 Special Stringing

A variation of the method described in paragraph 7.1, used for attaching fabric to metal ribs and known as 'special stringing' is shown in Figure 6.

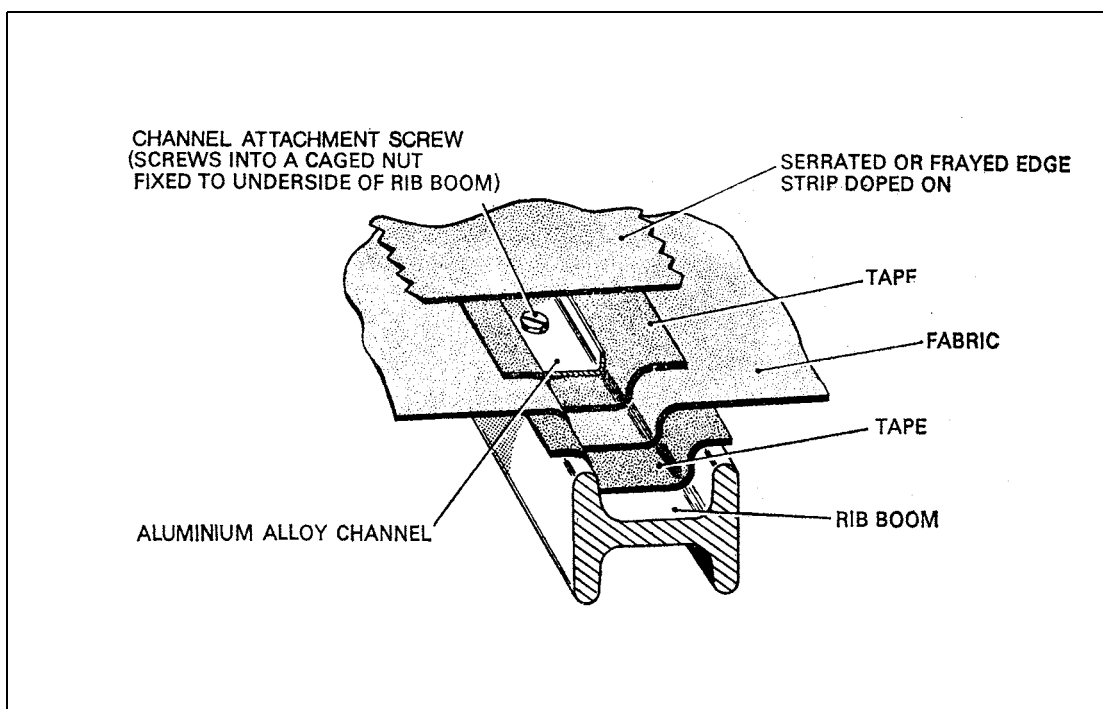

Figure 6 Special Stringing

7.3 Adhesives

On some small aircraft, where air loads are light, stringing is dispensed with on the wing and tail surfaces and the fabric is attached to the structure by means of a proprietary adhesive. This method produces a much smoother surface on the components and saves time during manufacture and repair.

7.4 Attachment of Fabric to Plywood

Dope is generally used for the attachment of fabric to plywood, but before the fabric is applied, the wood surface should be smoothed with fine glass paper and any cavities, such as those caused by the countersinking for screwheads, filled and allowed to set. The filler area should be reduced to an absolute minimum because of the reduced adhesion of the doped fabric in such areas.

7.4.1 The wooden surface should then be treated with one coat of tautening dope, followed by a further coat after the first one has dried. After the second coat of dope has dried, the fabric should be spread over the wood and stretched evenly to avoid wrinkling. A

coat of tautening dope should then be brushed into the fabric sufficiently to ensure good penetration. For this purpose a fabric pad is useful for rubbing in the dope.

- 7.4.2 After the dope has dried it should be lightly rubbed down using 'wet and dry' rubbing paper Grade 0 or Grade 00 and then the required finishing scheme applied.

7.5 **Attachment of Fabric to Metal Surfaces**

Where a light alloy is used as part of the structure of a mainplane (such as to form the leading edge profile) the fabric is generally doped into position. Alternatively, a thermoplastic adhesive may be used and guidance on the use of this material may be obtained from the relevant aircraft manuals.

- 7.5.1 To ensure satisfactory adhesion of the fabric, the metal surfaces should be thoroughly cleaned and primed with an etch primer.

8 Drainage and Ventilation

Drainage and ventilation holes are necessary in fabric-covered components to minimise corrosion of the structure, rotting of the fabric, etc., and, to ensure maximum efficiency, it is important that they should be positioned as prescribed on the relevant drawing.

- 8.1 Drainage holes are usually positioned in the lower surface of components or wherever entrapment of moisture is possible, but when holes are used for ventilating purposes, e.g. to permit the air pressure inside the component to equalise with the surrounding air at various altitudes, the holes may be located in sheltered positions regardless of drainage qualities.

8.2 **Drainage Eyelets**

Drainage eyelets are usually oval or circular in shape and are doped onto the surface of the fabric, but in some cases may be secured by stitching through pre-pierced holes in the eyelets before the finishing scheme is applied.

8.3 **Shielded Eyelets**

Shielded or shrouded eyelets are sometimes used in special positions to improve either drainage or ventilation. On marine aircraft they are used to prevent the entry of sea spray. These special eyelets must only be used in specified positions and must not be used as an alternative to standard eyelets. It is also important that the shroud is facing in the correct direction, otherwise it will not be fully effective.

NOTE: Inspectors must ensure that drain holes are clear; it is common practice to affix the eyelets at an early stage of doping and to pierce the fabric after the final finish has been applied.

9 Inspection Panels

For inspection and servicing purposes it is essential that access be provided at specified positions in all fabric coverings. The three methods commonly used are described below.

9.1 **Woods Frames**

These are light circular or square frames, made from celluloid sheet, which are doped onto the fabric cover at the required positions. The fabric is then cut away from inside the frames and a serrated edged fabric patch doped over the hole as shown in Figure 7. The disadvantage of this type of panel is that a new patch must be doped on after each inspection and the finishing scheme re-applied.

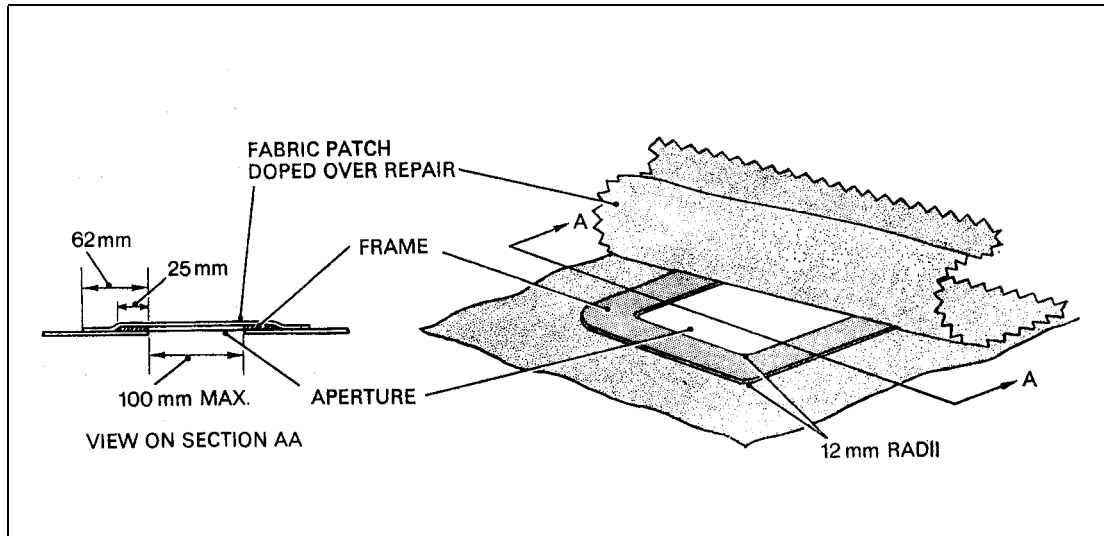

Figure 7 Woods Frame Inspection Panel

9.2 Zip Panels

These consist of two zip fasteners sewn into the fabric in the form of a vee, the open ends of each fastener being at the apex of the vee. This type of access is suitable for positions where frequent inspection or servicing is necessary. Care should be taken to avoid clogging the zip segments when dope is applied to the fabric.

9.3 Spring Panels

A panel particularly suitable for use on light aircraft, is the spring panel which consists of a circular plastic ring and dished light alloy cover. The ring is doped into position in the same way as the Woods Frame and the fabric cut away from the inside. By pressing the centre of the cover the dish shape is reversed, allowing the clip to be inserted in the hole; when pressure is released the dish reverts to its normal shape and closes round the plastic ring as shown in Figure 8.

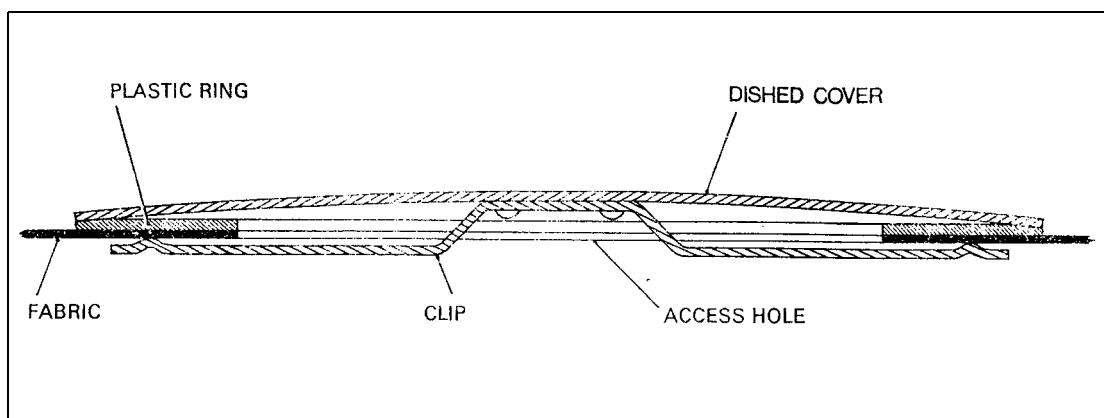

Figure 8 Cross-section of Spring Panel

10 Repairs to Fabric Coverings

If the fabric has been damaged extensively, it is usually impractical and uneconomical to make satisfactory repairs by sewing and patching. The extent and location of damage to the fabric that may be repaired will be detailed in the repair section of the

aircraft manual concerned, but extensive damage is often made good by replacing complete fabric panels. However, the replacement of large fabric panels, particularly on one side of a component, may lead to distortion of the structure and it may be advisable to completely re-cover the component.

10.1 Before attempting any repair to the fabric covering, the cause of the damage should be ascertained. The internal structure should be inspected for loose objects such as stones, remains of birds, insects, etc., and any structural damage made good. Using thinners, all dope should be removed from the fabric surrounding the damaged area before any stitching is carried out, since doped fabric will tear if any tension is applied to the repair stitches.

10.2 **Repair of Cuts and Tears**

Cuts and tears in fabric are sometimes caused by stones thrown up by the slipstream or wheels, but more generally result from accidental damage during ground movement or servicing. Damage may also be caused by bird strikes. Any damaged structure should be made good and fabric repairs carried out according to the type of damage, as detailed in the following paragraphs.

10.2.1 **Herring-Bone Stitch**

The herring-bone stitch (also known as the 'ladder stitch') should be used for repairing straight cuts or tears which have sound edges. The stitches should be made as shown in Figure 9, with a lock knot every 150 mm (6 in).

- a) There should be a minimum of two stitches to the centimetre (four stitches to the inch) and the stitches should be 6 mm (0.25 in) from the edge of the cut or tear. The thread used should be that described in paragraph 3.3.

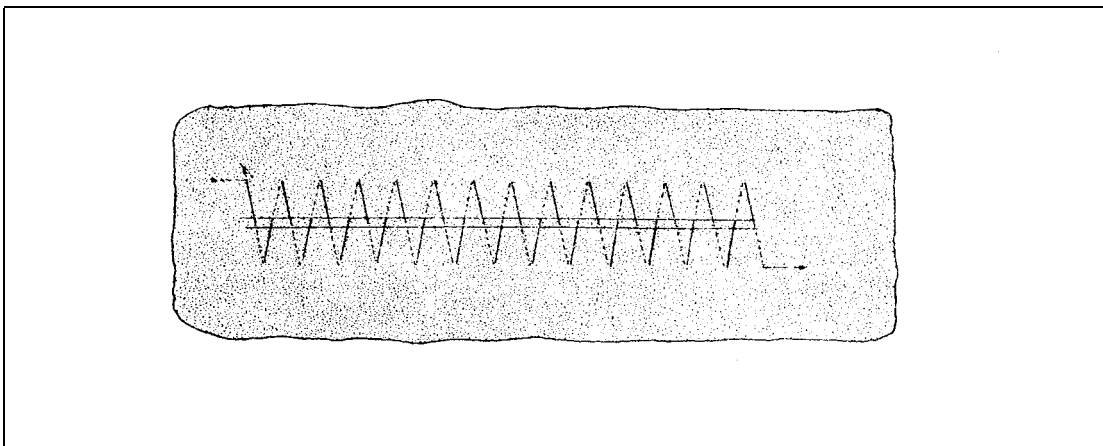

Figure 9 Herring-Bone Stitch

- b) After the stitching has been completed, 25 mm (1 in) wide serrated tape should be doped over the stitching. A square or rectangular fabric patch should then be doped over the whole repair, ensuring that the edges of the patch are parallel to the warp and weft of the fabric covering and that they overlap the repair by 37 mm (1.5 in). The original dopping scheme should then be restored.

10.2.2 **Repairs with Woods Frames**

On some aircraft, repairs to cuts and tears with jagged edges, which cannot be stitched as described in the previous paragraphs, can be repaired by using the Woods frame method described for inspection panels in paragraph 9.1. Repairs of up to 50 mm (2 in) square may be made, provided they are clear of seams or attachments

by a distance of not less than 50 mm (2 in). The affected area should be cleaned with thinners or acetone and repaired in the following manner:

- a) The Woods frame should be doped into position surrounding the damaged fabric and, if the frame is of the square type, the edges should be parallel to the weft and warp of the covering. When the dope has dried, the damaged portion of the fabric should be cut out and the aperture covered by a fabric patch as described in paragraph 9.1.
- b) If Woods frames are not readily available they can be made from cellulose sheet 0.8 mm (0.030 in) thick with minimum frame width of 25 mm (1 in); in the case of the square type of frame the minimum corner radii should be 12 mm (0.5 in). In some special cases, aircraft manufacturers use 2 mm plywood complying with British Standard V3 for the manufacture of the frames, in which case it is important to chamfer the outer edges of the frame to blend with the aerofoil contour.

10.2.3 Repair by Darning

Irregular holes or jagged tears in fabric may be repaired by darning provided the hole is not more than 50 mm (2 in) wide at any point. The stitches should follow the lines of the warp and weft and should be closely spaced as shown in Figure 10. The whole repair should be covered with a serrated fabric patch in the usual way, with an overlap of 37 mm (1.5 in) from the start of the darn.

10.3 Repair by Insertion

For damage over 100 mm (4 in) square, insertion repairs are generally used, either of the two methods described below being suitable.

10.3.1 Normal Insertion Repair

- a) The damaged area of the fabric should be cut out to form a square or rectangular hole with the edges parallel to the weft and warp. The corners of the hole should then be cut diagonally, to allow a 12 mm (0.5 in) wide edge to be folded under the fabric and this should be held in position with tacking or hemming stitches.

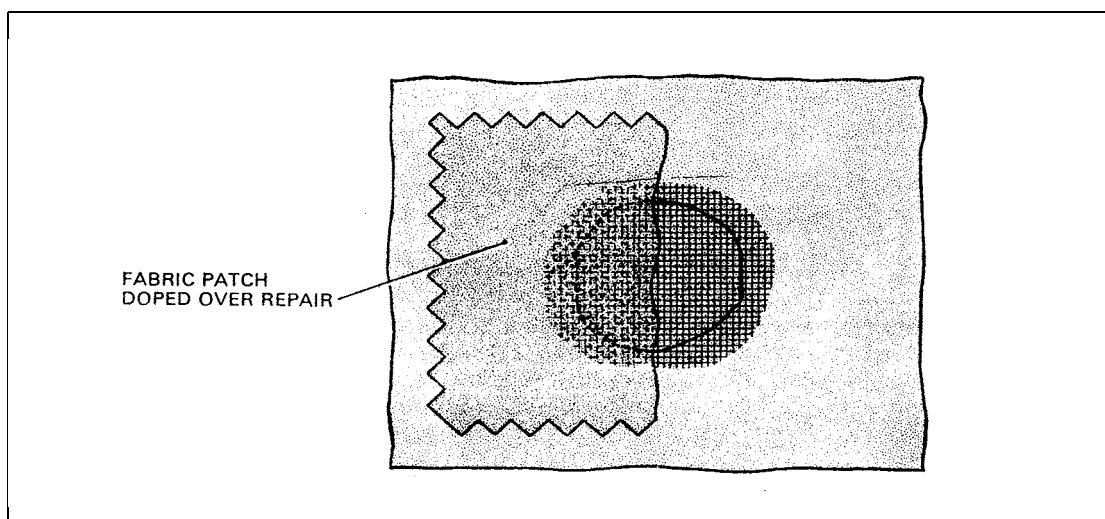

Figure 10 Repair by Darning

- b) The patch should be made 25 mm (1 in) larger than the cut-out area and its edges should be folded under for 12 mm (0.5 in) and tacked in position in a manner similar to that described in paragraph 10.3.1 a). In this condition the size of the insertion patch should be similar to, or slightly smaller than, that of the cut-out area.

- c) The insertion patch should be held in position inside the cut-out area with a few tacking stitches and then sewn in position using a herring-bone stitch of not less than two stitches to the centimetre (four stitches to the inch), as shown in Figure 11. A 25 mm (1 in) wide tape should then be doped over the seams.

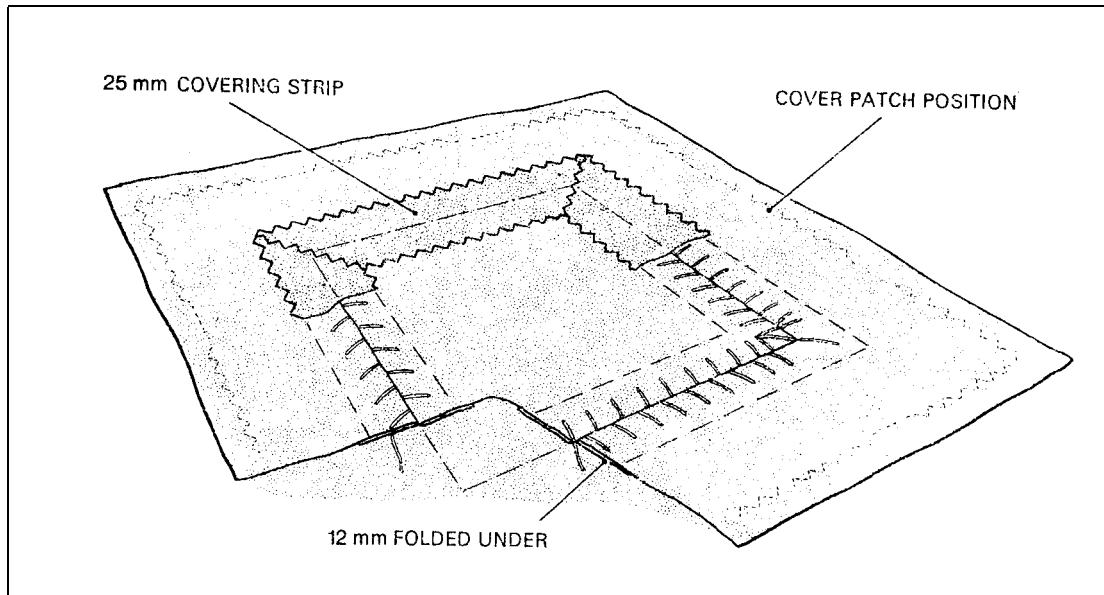

Figure 11 Normal Insertion Repair

- d) For small repairs a square or rectangular cover patch, with frayed or serrated edges, should be doped in position ensuring that the patch overlaps the edge of the tape by 31 mm (1.25 in). Where the size of the insertion patch is more than 225 mm (9 in) square, a 75 mm (3 in) wide fabric serrated tape is often used; the tape should be mitred at the corners and doped in position. The original finish should then be restored.

10.3.2 Alternative Insertion Repair

An alternative repair is shown diagrammatically in Figure 12. This consists of cutting away the damaged fabric as described in paragraph 10.3.1, but, in this case, the edges of the aperture as well as the edges of the insertion patch are turned upwards. The insertion patch is attached to the fabric cover by stitching along the folded-up edges as near to the contour of the component as practicable (i.e. about 1 mm (0.0625 in) above the surface) using the boot stitch described in paragraph 10.3.3 (Stage 1 of Figure 12). The edges are then doped down (Stage 2 of Figure 12) and the repair covered with a doped-on fabric patch.

10.3.3 Boot Stitch

A single, well-waxed No.18 linen thread to BS F34 should be used for the boot stitch. The stitches should be made as shown (diagrammatically) in Figure 13 and the ends of both threads tied together in a lock knot every 150 mm (6 in), and at the end of a seam.

11 Checking of Fabric

The fabric covering of an aircraft will deteriorate in service, the rate of deterioration depending, to a large extent, on the type of operation, climate, storage conditions and the maintenance of a satisfactory surface finish. In addition, as a result of water

soakage, chafing against structure and local wear, the covering will not deteriorate uniformly. In the case of fabric covered components on large aircraft, an arbitrary life may be placed on the fabric, but with light-aircraft coverings the fabric should be checked at the periods specified in the approved Maintenance Schedule and prior to renewal of the Certificate of Airworthiness.

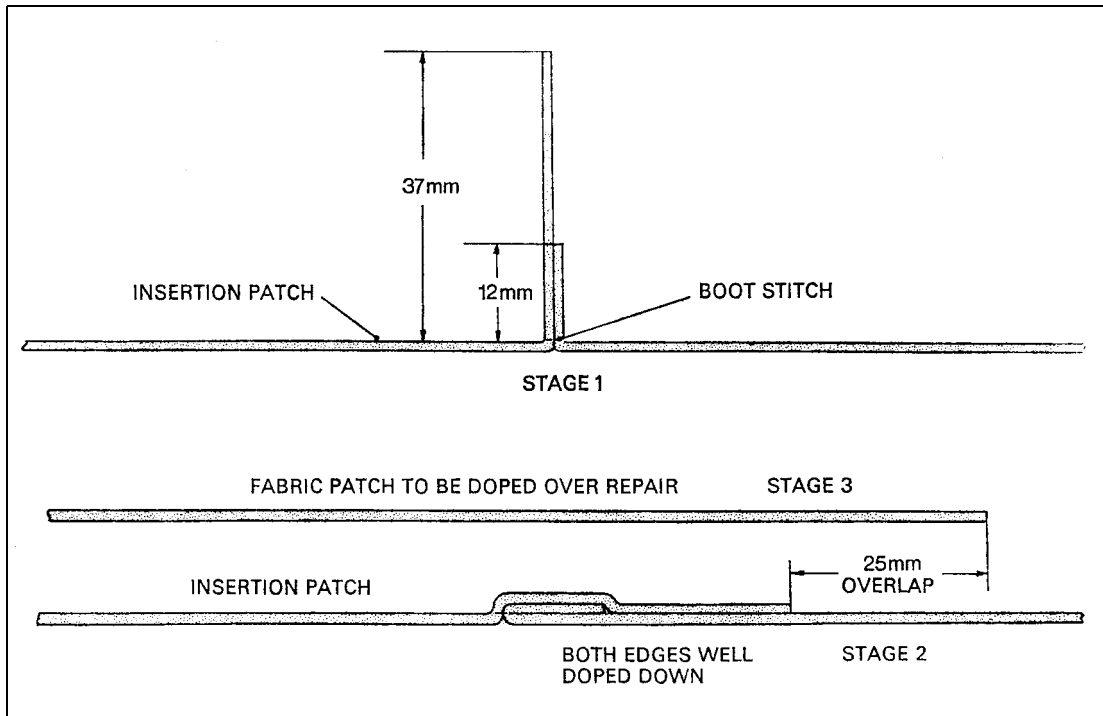

Figure 12 Alternative Insertion Repair

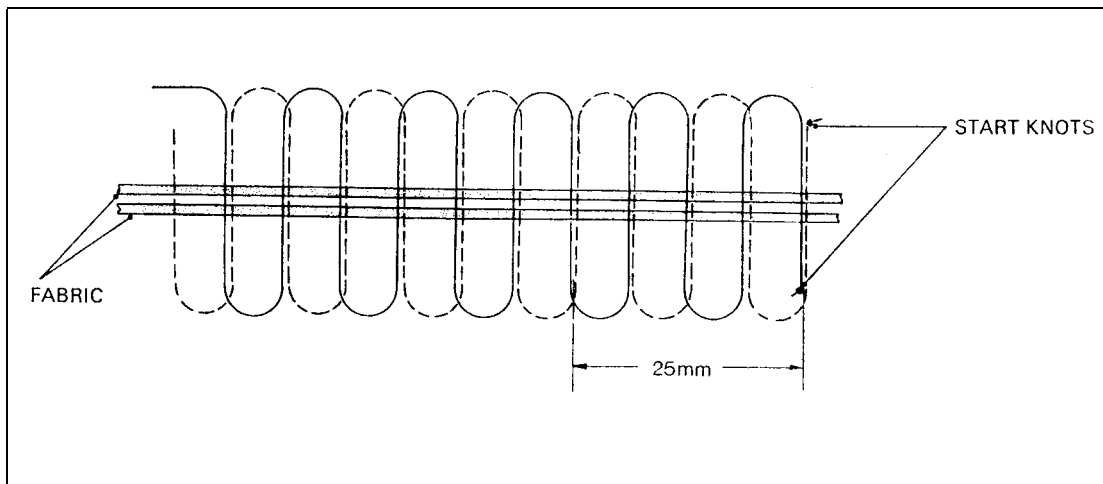

Figure 13 Boot Stitch

- 11.1 A visual examination in which particular attention is given to places where water soakage, local wear, fretting or oil contamination are likely to occur, or are known to occur on that particular aircraft type, supplemented by a knowledge of the aircraft history, will often be sufficient to justify acceptance of the covering as a whole, or replacement of some local areas which have deteriorated. In cases of doubt as to the strength of the fabric, further tests will be necessary.

11.2 One method of checking the strength of an aircraft covering is by the use of a portable tester such as the one described in paragraph 11.3 and illustrated in Figure 14. These testers are, generally, only suitable for checking the condition of coverings on which the dope finish has penetrated the fabric. Finishes such as cellulose acetate butyrate dope do not normally penetrate the fabric and experience has shown that the absorption of moisture in humid conditions can produce unreliable test results. In addition, butyrate dope, even when some penetration of the fabric has occurred, produces a finish which hardens with age; as a result the conical point on the tester will not readily penetrate the covering and the test will tend to indicate that the fabric is stronger than it actually is. Thus where butyrate dope has been used, or the dope, irrespective of type, does not penetrate the fabric, laboratory tests should be carried out. For a laboratory test the dope should be removed from the fabric, using a suitable solvent where necessary. Fabric having a strength of at least 70% of the strength of new fabric to the appropriate specification (as assessed by either test), may be considered airworthy, but fabric which falls only just within the acceptable range should be checked more frequently thereafter to ensure continued serviceability.

11.3 **Portable Tester**

This consists of a penetrating cone and plunger housed within a sleeve assembly. When pressed against a surface the cone is forced up through the sleeve against spring pressure and the plunger projects through the top of the sleeve in the same way as a tyre pressure gauge. When inspecting fabric, the tester should be held at 90° to the surface and pressure applied towards the fabric in a rotary motion, until the sleeve flange touches the surface (Figure 14). The degree to which the cone has penetrated the fabric is indicated by the length of plunger showing above the sleeve and this is marked either by coloured bands or a graduated scale.

11.3.1 A table is provided with the tester giving the colour or scale reading required for a particular type of fabric.

NOTE: The portable tester described here is of American manufacture and the table supplied refers to fabric complying with American specifications (AMS, TSO and MIL). It can be adapted for use on fabrics complying with DTD and BS specifications by comparing the strength requirements of the fabrics.

11.3.2 The test should be repeated at various positions and the lowest reading obtained, other than in isolated repairable areas, should be considered representative of the surface as a whole.

NOTE: It is important to ensure that the test is not made through double layers of fabric, since this would not be representative of the entire surface.

11.3.3 All punctures produced by the tester should be repaired with a 50 mm or 75 mm (2 in or 3 in) diameter doped fabric patch.

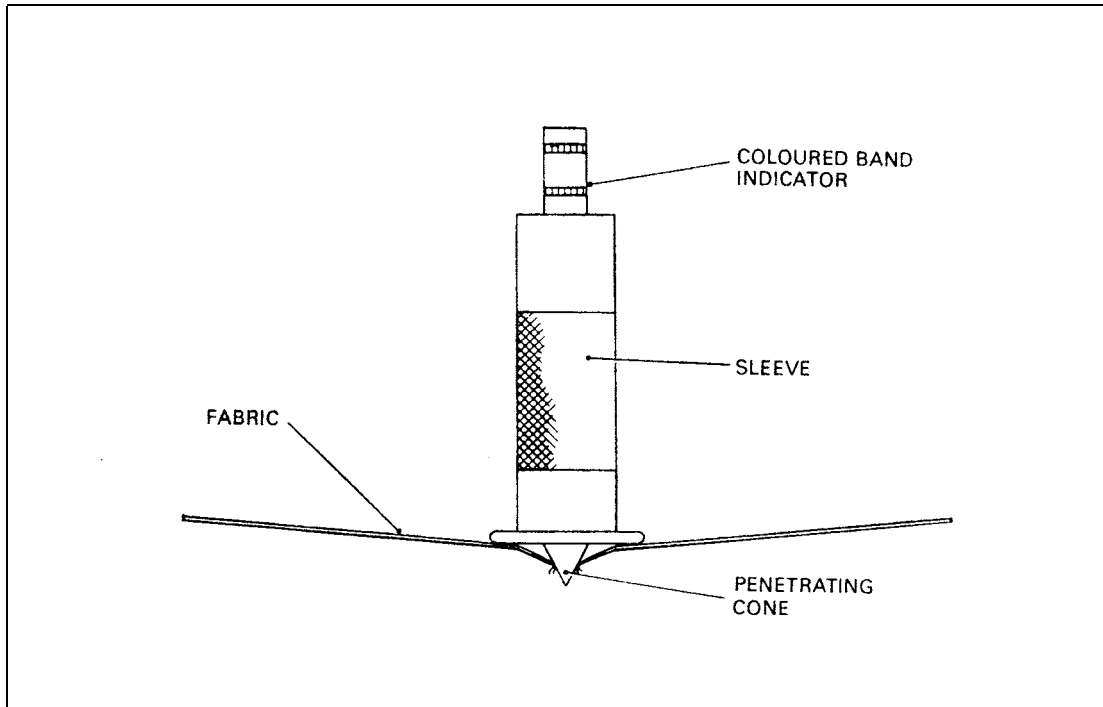

Figure 14 Fabric Tester

11.4 Laboratory Tests

Tensile strength tests are included in laboratory tests specified for new fabric and require the use of six warp and six weft samples, each 62 mm x 300 to 400 mm (2.5 in x 12 to 16 in). These tests are thus an uneconomical proposition for used fabric coverings on aircraft, since they would necessitate partial re-covering even if the fabric proved to be serviceable. It is recommended, therefore, that when the portable tester is considered unsatisfactory or inappropriate, samples of fabric should be sent to a laboratory acceptable to the CAA, for bursting strength tests in accordance with the specification for the particular type of fabric. These tests require the use of samples approximately 87 mm (3.5 in) in diameter.

- 11.4.1 Bursting strength tests can be carried out on a machine operating on the principle of applying force to a polished steel ball of 25.40 mm (1.00 in) diameter, the ball being in contact with the test sample, which is clamped between two circular brass plates having coaxial apertures of 44.45 mm (1.75 in) diameter. The load should be applied at a constant rate and the load at break point is the bursting strength of the fabric. An Instron machine, which operates on this principle, is suitable for conducting tests on used aircraft fabric. As an alternative, a machine operating on hydraulic principles can be used; in such a machine, liquid pressure is applied at a constant rate to a rubber diaphragm, which is positioned to expand through a clamp aperture of 30.99 mm (1.22 in) diameter, exerting force against the fabric sample held between the clamps.

NOTE: The test methods referred to above are in accordance with the American Federal Test Method Standard No.191, Methods 5120 and 5122 respectively.

12 Man-made Fabrics

Natural fabrics, such as cotton or linen, deteriorate in use as a result of the effects of sunlight, mildew or atmospheric pollution and may require replacement several times during the life of an aircraft. With a view to lengthening the intervals between fabric

replacements, several man-made fabrics have been developed and are approved in some countries for use on specific aircraft. The two main types of materials are polyester-fibre and glass-fibre, which are marketed under various trade names. The methods of covering aircraft with these fabrics are briefly discussed in paragraphs 12.1 and 12.2, but it is important that the instructions issued by the manufacturer of the aircraft or fabric should be carefully followed and only the specified materials used.

12.1 **Polyester-Fibre Materials**

These materials may be attached to the structure by the method described in paragraph 5, by use of pre-sewn covering envelopes or by use of an approved adhesive at the points of contact with the structure. The materials used for attachment and stringing must be compatible with the main fabric.

12.1.1 Before stringing, polyester fibre covers are tautened by the application of heat, the degree of shrinkage being proportional to the heat applied. The most common method of applying heat is a household iron set at about 120°C ('wool' setting), and used in an ironing motion. Care is necessary to prevent the application of excessive heat as this may melt the fibre, or overtauten the cover and distort the underlying structure. Where non-tautening dope is used, the cover may be fully tautened prior to doping, but where tautening dope is used the initial shrinkage should leave the cover fairly slack, since tautening will continue over a period of months after the dope has been applied.

12.1.2 Repairs within the specified limits may be carried out as described in paragraph 10, or patches may be stuck on, using a suitable adhesive. Large patches should be tautened in the same way as the main cover.

12.2 **Glass-Fibre Materials**

Glass-fibre fabric is normally fitted to the mainplane and tailplane in a spanwise direction, being attached at the leading and trailing edges with a 50 mm (2 in) doped seam. Fuselages may conveniently be covered using four pieces of material at the top, bottom and sides, doped seams again being employed. Some glass-fibre material is pre-treated to make it compatible with cellulose acetate butyrate dope and is not suitable for use with cellulose nitrate dope.

12.2.1 The structure should be prepared by removing all sharp edges from the parts which will be in contact with the cover. Wooden parts should be lightly sanded and metal edges taped to prevent chafing.

12.2.2 Glass-fibre material is only slightly tautened by doping and must be a good initial fit, after which glass-fibre stringing should be fitted in the appropriate manner (paragraph 6.4).

12.2.3 Repairs within the specified limits may be made by cutting out the damaged area of fabric and doping on a cover patch which overlaps 50 mm (2 in) all round.

INTENTIONALLY LEFT BLANK

Leaflet 51-160 Doping

1 Introduction

Fabric has been used from the early days of the aeroplane as a covering for fuselages and aerofoils. It still continues to provide good service for light aircraft but must be protected from deterioration by the application of a dope film. Natural fabrics, such as cotton or linen, deteriorate in use as a result of the effects of sunlight, mildew and atmospheric pollution. Man-made fibres resist some of these agents better than natural fabrics but still require protection. The dope film then achieves the following functions:

- a) Tautening of natural fabrics,
- b) Waterproofing,
- c) Airproofing,
- d) Lightproofing.

- 1.1 The purpose of this Leaflet is to provide guidance and advice on the appropriate working conditions and methods of application of dope to aircraft fabric. Other Leaflets with related information are 51-140 Paint Finishing of Metal Aircraft and 51-150 Fabric Covering.

2 Materials

The basic film consists of dope but other materials are used in its application, as described in the following paragraphs.

2.1 Dopes

Dope consists of a number of resins dissolved in a solvent to permit application by brush or spray. This formulation is then modified with plasticisers and pigments to add flexibility and the required colour (see Figure 1). There are two types of dope in use, namely, cellulose nitrate and cellulose acetate butyrate. The former is usually known simply as nitrate dope and the latter as butyrate or CAB dope. The main difference between the two types of dope is the film base. In nitrate dope a special cotton is dissolved in nitric acid, whilst in butyrate dope cellulose fibres are dissolved in acetic acid and mixed with butyl alcohols. The plasticisers in the two dopes are also different, as are the resin balance and solvent balances. Dope must be stored under suitable conditions (see Leaflet D-40), and has a tendency to become acid with age; if old dope is used for refinishing an aircraft it will quickly rot the fabric. Only fresh dope should be used, preferably buying it for the job in hand.

2.2 Dope-Proof Paints

Due to the nature of the solvents used in dope, many paints will be attacked and softened by it. Dope-proof paint is therefore used to coat structure which will be in contact with the doped fabric. In the case of wooden structure, spar varnish provides a good dope-resistant finish and an epoxy primer is suitable for metal structures.

2.3 Aluminium Dope

To make the fabric lightproof and so prevent damage from ultra-violet radiation, an aluminium dope is used. This is usually supplied ready mixed but can be prepared by mixing aluminium paste or powder in clear dope but it is essential that the materials

are obtained from an approved supplier and mixed in accordance with the manufacturer's instructions.

2.4 Thinners

Dopes are formulated in such a way that the solid constituents are suspended in the appropriate solvents. It will normally be necessary to thin or reduce the dope to make it suitable for spraying. It is important that only the thinners recommended by the manufacturer of the dope is used. The amount of thinners is determined from the manufacturer's recommendations and is modified by experience to take account of the equipment used and the atmospheric conditions. The viscosity can be measured by using a viscosity cup which contains a small hole in the bottom. In use, the cup is dipped into the dope and the flow of fluid is timed from when the cup is lifted from the container to the first break in the flow. In this way subsequent batches of dope can be mixed to exactly the same viscosity as the first batch. It is important that nitrate and butyrate dopes are mixed only with their own specialised thinners. A retarder, or anti-blush thinners, is a special type of thinners with slow-drying solvents. By drying more slowly they prevent the temperature drop and consequent moisture condensation that cause blushing in a dope finish. In use, the retarder replaces some of the standard thinners and can be used in a ratio of up to one part retarder to four parts of thinners. The use of more retarder than this is unlikely to achieve the desired result.

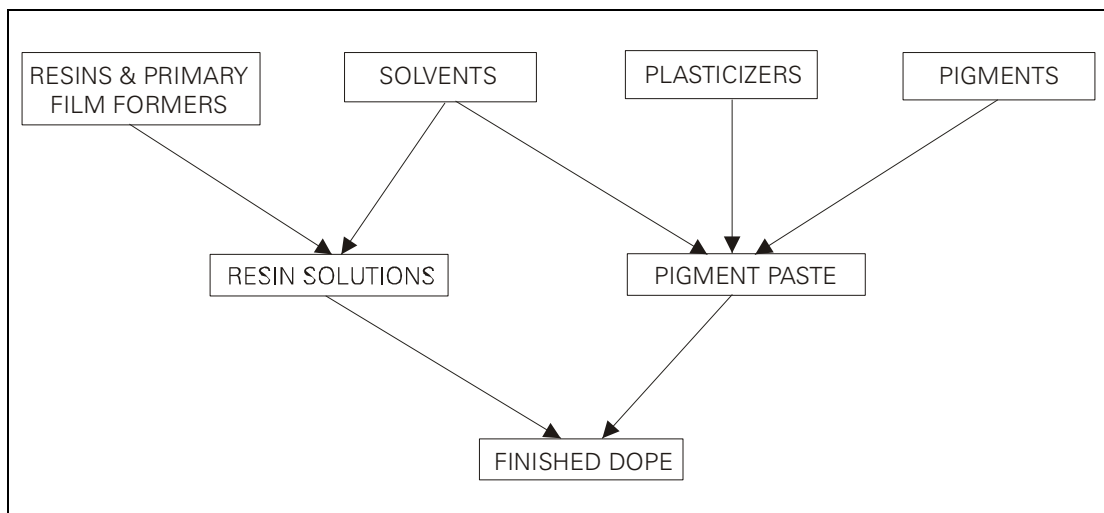

Figure 1 Dope Constituents

2.5 Cleaning Agent

Methyl-ethyl-ketone (MEK) is an important, relatively low cost, solvent similar to acetone. It is widely used as a cleaning agent to remove wax and dirt and to prepare surfaces for painting or re-doping. It is also useful as a solvent for cleaning spray guns and other equipment.

2.6 Fungicides

Since natural fabrics can be attacked by various forms of mildew and fungus, it may be necessary to provide protection for cottons and linens when doping. This is achieved by having a fungicide added to the first coat of dope. The dope is usually supplied ready mixed but can be prepared by using a fungicidal paste obtained from an approved supplier. If the latter course is necessary, the fungicidal paste should be mixed with the clear dope in accordance with the manufacturer's instructions; all fungicides are poisonous and therefore, standard precautions should be taken to

prevent any ill effects. Since mildew or mould form on the inside of the fabric, it is important to ensure that this first coat of dope completely penetrates the fabric.

2.7 Tack Rags

A tack rag is a rag slightly dampened with thinners and is used to wipe a surface after it has been sanded to prepare it for the application of the next coat. Proprietary cloths are also available.

2.8 Sandpaper

Sanding is carried out using wet-or-dry paper. This is a waterproof sandpaper that will remain flexible and not clog. The grades most likely to be used are 280, 360 and 600, the last mentioned being the finest grade.

2.9 Drainage Eyelets and Inspection Rings

Openings in the fabric cover for drain holes and inspection panels are always reinforced with eyelets or grommets (see Figure 2) and inspection rings. These are made from cellulose nitrate sheet and are doped into position (see Leaflet 51-150).

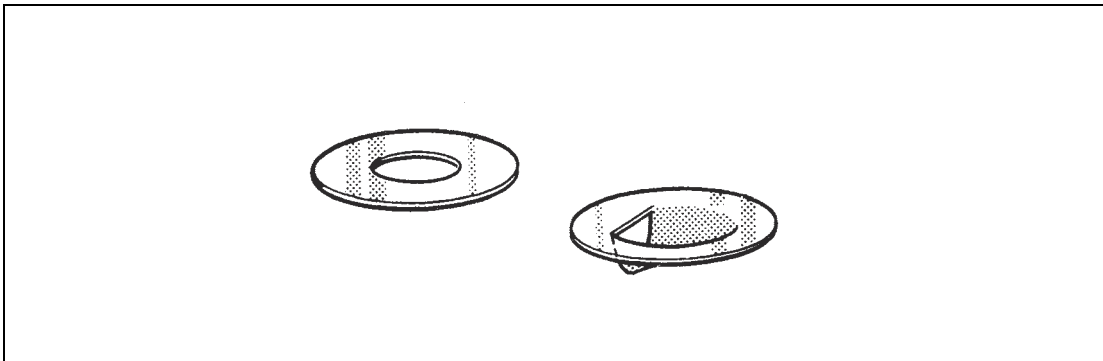

Figure 2 Plain and Shielded Drainage Eyelets

3 Safety Precautions

The storage and use of dopes is covered by various Government regulations made under the Factories Act. This paragraph does not replace or override any of those regulations.

- 3.1 The hazard with the use of dopes comes about because of the flammability of the solvents that are used. The solvents have a low flash point and the vapour produced is heavier than air. Accumulations of vapour are readily ignited producing a serious fire which can spread very rapidly.
- 3.2 One of the most common causes of ignition is a spark produced by the discharge of static electricity. For example, during the course of doping, the fumes from the solvents will accumulate inside the structure. When the dope has dried, subsequent dry sanding and dusting will build up a static charge on the surface. If the operator is wearing rubber soled shoes he will be at the same electrical potential as the surface and nothing will happen. Should the charge on the operator now be lost through his touching some metal part of the spray shop, for example and he then touches some metal part of the structure being doped the static charge will jump to earth creating a spark and igniting the fumes. The best way to prevent this type of problem is to eliminate the static charge altogether by grounding the structure being doped. A wire connected from the structure to a clean metal part of the spray shop will do the job satisfactorily. Clothing that is made of synthetic fibres will build up a static charge

more readily than that made from cotton. Leather soled shoes will allow any static charge to be dissipated to ground. When spraying nitrate dope ensure that the spray gun, the operator and the structure being doped are all grounded together.

- 3.3 The standard of housekeeping in the spray shop is an important aspect of safety. If the floor becomes contaminated with dried nitrate dope overspray, subsequent sweeping will produce a static charge with the attendant risk of ignition and possible explosion. To clean the floor, it should be doused well with water and then swept whilst it is still wet. Since dopes will not be the only materials used in a spray shop, it should be noted that spontaneous combustion can be the result of a mixing of dope and zinc chromate oversprays.
- 3.4 The fumes created during the spraying process are hazardous to health as well as being a fire risk. Proper operator protection must be provided as recommended in the dope manufacturer's technical literature. At the first sign of any irritation of the skin or eyes, difficulty in breathing or a dry cough, the operator should stop work and seek medical advice.
- 3.5 Electrical equipment to be used in the spray shop must be of such a nature that it cannot ignite the vapours that will be present. Lead Lamps must be of the explosion-proof variety and dopes must not be mixed using stirrers driven by portable electric drills.

4 Working Conditions

In order to accomplish a proper dope job, it is important to control both the temperature and humidity of the air in the spray shop. In addition to this it is necessary to maintain sufficient air flow through the shop to remove the heavy vapours caused by atomisation and evaporation of the solvents used.

- 4.1 To maintain a suitable air flow through the spray shop it is necessary to install a fan at floor level since the vapours produced are heavier than air. The fan must be explosion proof, as must be all other electrical equipment installed in the area. The rate of air flow is dictated by the size of the spray shop and is the subject of various Government regulations. The discharge of the vapours may also be the subject of further requirements and the advice of the Factory Inspectorate should be sought. The air inlet to the spray shop should preferably be in an adjoining room, or at least behind a suitable baffle, in order to reduce draughts to a minimum. If the inlet is in a separate room then the air temperature can be raised to that required before entering the spray shop.
- 4.2 Many problems associated with doping can be traced to incorrect temperatures of the air or the dope. If the dope has been left overnight in a cold place then it will take many hours to bring it to the room temperature. Overnight heating of the spray shop is the most satisfactory method to prepare for doping since it usually results in more uniform temperatures throughout the shop. Rapid heating tends to result in stratified heating with the ceiling being considerably hotter than the floor level. Air temperature should be maintained between approximately 21° and 26°C (70° to 79°F) for best results. If the temperature is too low the rapid evaporation of the solvents will lower the temperature of the surface to the point where moisture will condense and be trapped in the finish. Too high a temperature causes very rapid drying of the dope which can result in pin holes and blisters. The only satisfactory way to operate is to constantly monitor and control the air temperature as necessary.

Table 1 Relative Humidity (%)

Dry Bulb Reading (°C)	Depression of the Wet Bulb (°C)									
	1	2	3	4	5	6	7	8	9	10
0	82	–	–	–	–	–	–	–	–	–
1	83	–	–	–	–	–	–	–	–	–
2	84	68	–	–	–	–	–	–	–	–
3	84	69	54	–	–	–	–	–	–	–
4	85	70	56	42	–	–	–	–	–	–
5	86	72	58	45	32	–	–	–	–	–
6	86	73	60	47	35	23	–	–	–	–
7	87	74	61	49	37	26	14	–	–	–
8	87	75	63	51	40	29	18	7	–	–
9	88	76	64	53	42	31	21	11	1	–
10	88	77	65	54	44	34	24	14	5	–
11	88	77	66	56	46	36	26	17	8	–
12	89	78	68	57	48	38	29	20	11	3
13	89	79	69	59	49	40	31	23	14	6
14	90	79	70	60	51	42	33	25	17	9
15	90	80	71	61	52	44	36	27	20	12
16	90	81	71	62	54	46	37	30	22	15
17	90	81	72	64	55	47	39	32	24	17
18	91	82	73	65	56	49	41	34	27	20
19	91	82	74	65	58	50	43	35	29	22
20	91	83	74	66	59	51	44	37	30	24
21	91	83	75	67	60	52	46	39	32	26
22	92	83	76	68	61	54	47	40	34	28
23	92	84	76	69	62	55	48	42	36	30
24	92	84	77	69	62	56	49	43	37	31
25	92	84	77	70	63	57	50	44	38	33
26	92	85	78	71	64	58	51	46	40	34
27	92	85	78	71	65	59	52	47	41	36
28	93	85	79	72	65	59	53	48	42	37
29	93	86	79	72	66	60	54	49	43	38
30	93	86	79	73	67	61	55	50	44	39
31	93	86	80	73	67	62	56	51	45	41
32	93	86	80	74	68	62	57	52	46	42
33	93	87	80	74	69	63	58	52	47	43
34	93	87	81	75	69	64	58	43	48	44
35	93	87	81	75	70	64	59	54	49	44

NOTE: Intermediate values may be obtained by interpolation.

- 4.3 In addition to the proper control of air temperature, the humidity of the air must also be controlled. The desirable range of air humidity is 45 to 50%. Satisfactory work can be produced with air humidity as high as 70% or as low as 20%, depending upon other variables such as temperature and air flow, but the control of the dope application at extremes is always more difficult.
- 4.4 Humidity should be measured with a hygrometer and although direct reading instruments are available, the wet and dry bulb type is still the most common. In this instrument two thermometers are mounted side by side, the bulb of one being kept wet by water evaporating through a wick. To take a reading of humidity, both thermometers should be read and the difference between them noted; the wet bulb thermometer will be lower. After finding the dry bulb reading in Table 1, a reading

should be taken across to the column headed with the depression of the wet bulb. The relative humidity as a percentage is given at the intersection of the two lines. Example. Assuming a dry bulb reading of 17°C and a wet bulb reading of 14°C, the depression of the wet bulb, that is the amount by which the reading of the wet bulb is reduced below that of the dry bulb, is 3°C. Reading across from 17°C in the dry bulb column to the depression column headed 3°C indicates a relative humidity of 72%.

- 4.5 In order to produce a satisfactory dope film, it is vitally important that all brushes, spray equipment and containers should be scrupulously clean. It is important that oil and water traps in the air lines are properly cleaned and that air reservoirs are drained of accumulated moisture. Pressure pots and spray guns should be thoroughly cleaned with thinners before the dope hardens. If passages have become obstructed with dried dope, the equipment should be dismantled and the parts soaked in methyl-ethyl-ketone or a similar solvent. Packings and seals should never be soaked in solvents or they will harden and become useless.

5 Preparation Prior to Doping

Before the component is moved into the spray shop, normal housekeeping tasks should be carried out. All dirt, dust and dried overspray should be removed, bearing in mind the safety precautions in paragraph 3.3. Then the working conditions of temperature and humidity should be achieved with the dope and other materials being brought to the correct temperature.

- 5.1 An inspection should be made of the fabric-covered component to verify the following points:
- a) The structure has been painted with dope-proof paint where required.
 - b) Correct and secure attachment of the fabric to the structure.
 - c) Correct allowance for tautening of the cover where this is of a natural fabric such as cotton or linen. If the cover is too slack, no amount of doping will rectify this. If it is too tight, a lightweight structure, such as a control surface, could easily be distorted.
 - d) All dust has been removed from the fabric.
 - e) The fabric has reached the temperature of the air in the spray shop.
 - f) Plastics components, such as windows and windscreens, are adequately protected against solvent attack; newspaper is not satisfactory for this purpose.
- 5.2 With the dope at the correct temperature, it should be mixed and then thinned to a suitable consistency for brush or spray application as appropriate. Whilst the dope is in storage the solid materials tend to settle and the purpose of mixing is to bring these materials back into suspension. To mix any dope satisfactorily, half the contents of the tin should be poured into a clean tin of the same size. The remaining material should be stirred until all the solid material is in suspension, paying particular attention to the bottom of the tin. The contents of the first tin should then be poured into the second tin and a check made that all pigment has been loosened from the bottom. Finally, the dope from one tin should be poured into the other and back again, until it is thoroughly mixed.

6 Application to Natural Fabric

The best looking and most durable film is produced by using multiple coats of a dope that is low in solids. A large number of thin coats, however, requires a great deal of time and modern dope schemes tend to use fewer, but thicker, coats than the earlier schemes. The dope scheme is a schedule listing the number and order of coats of each type of dope. Typical examples of schemes detailed in British Standard BS X26 are given in Tables 2, 3 and 4. The standard aircraft doping scheme is 752, but 751 is used on light structures that would be distorted by overtautening and 753 is used where an extra taut cover is required.

6.1 Priming Coats

This name is given to the first coats applied to the raw fabric. The first coat of dope provides the foundation for all the subsequent coats and as such its mechanical attachment to the fabric is very important. This mechanical attachment is formed by the dope encapsulating the fibres of the fabric. Nitrate dope has much better properties with regard to encapsulating the fibres and is therefore preferred for the first coat. The dope should be thinned by 25 to 50% and applied by brush. The dope should be worked into the fabric to ensure adequate penetration, but not to the point where it drips through to the opposite surface. Since organic fabrics are subject to attack by mildew, a fungicide should be added to the dope used for this first coat (see paragraph 2.6). When applying the first coat of dope to the wings, the entire wing should first be doped on both sides aft of the front spar. The dope should be allowed to shrink the fabric before doping the leading edge. In this way the fabric will tauten evenly and adjust itself over the leading edge cap without forming wrinkles.

Table 2 Low Tautness Scheme BS X26/751

Dope	Weight		Normally obtained in the following number of coats
	g/m ²	oz/yd ²	
(a) Transparent tautening dope	68	2.0	3 or 4
(b) Aluminium non-tautening finish	34	1.0	2
(c) Pigmented non-tautening finishes Where a glossy finish is required, follow with:	34	1.0	1 or 2
(d) Transparent non-tautening finish	34	1.0	1 or 2

NOTE: Where an aluminium finish is required, it is necessary to apply only (a) and (b) above, followed by (d) if required.

Table 3 Medium Tautness Scheme BS X26/752

Dope	Weight		Normally obtained in the following number of coats
	g/m ²	oz/yd ²	
(a) Red oxide tautening dope	68	2.0	3
(b) Aluminium tautening finish	34	1.0	2
(c) Pigmented non-tautening finishes Where an aluminium finish is required, the scheme should be:	34	1.0	1 or 2
(d) Red oxide tautening dope	102	3.0	4
(e) Aluminium non-tautening finish Where a glossy finish is required, follow with:	34	1.0	2
(f) Transparent non-tautening finish	34	1.0	1 or 2

Table 4 High Tautness Scheme BS X26/753

Dope	Weight		Normally obtained in the following number of coats
	g/m ²	oz/yd ²	
(a) Red oxide tautening dope	25.5	0.75	1
(b) Transparent tautening dope	161	4.75	6 or 7
(c) Aluminium tautening dope	34	1.0	2
(d) Pigmented non-tautening finishes Where an aluminium finish is required, the scheme should be:	34	1.0	1 or 2
(e) Red oxide tautening dope	25.5	0.75	1
(f) Transparent tautening dope	195	5.75	8
(g) Aluminium non-tautening finish Where a glossy finish is required, follow with:	34	1.0	2
(h) Transparent non-tautening finish	34	1.0	1 or 2

NOTE: A tolerance of $\pm 20\%$ is permissible on any of the weights given in Tables 2 to 4.

- 6.2 After the dope has dried for a minimum of 1 hour, the tapes, drainage eyelets or grommets and inspection panel rings may be applied (see Leaflet 51-150 for rib stitching procedures). A heavy coat of nitrate dope should be brushed on where required and the tape laid into it, working it down to the surface and rubbing out any air pockets as the tape is laid. A further coat of clear dope is brushed over the top of the tapes. Drainage eyelets or grommets and inspection rings are attached in a similar fashion at this time. To ensure the best adhesion, eyelets or grommets and rings may be soaked in dope thinners for no more than two minutes to soften them. Inspection rings are best reinforced with a circular pinked-edge patch, a little larger than the ring, doped over the top. The holes in eyelets or grommets and rings are opened with a

sharp, pointed knife after doping is complete. The taping is followed by another coat of clear dope which may be butyrate and may be applied by spray gun.

6.3 **Filling Coats**

When the first butyrate coat has fully dried, the fabric will feel rough due to the short fibre ends (the nap) standing up. This nap should be very lightly sanded off, using dry sandpaper, to leave a smooth finish. The surface should then be rinsed clean with water and dried thoroughly. Two full wet cross-coats of butyrate dope should now follow; a cross-coat is a coat of dope sprayed on in one direction and then covered with a second coat at right angles to it before the first coat dries. These in turn should be followed with one good cross-coat of aluminium dope after lightly sanding the clear dope to encourage adhesion. The aluminium coat is in its turn lightly wet sanded to produce a smooth surface and the residue rinsed off with water. Once the aluminium coat has dried, it should be checked for continuity by shining a light inside the structure. The film should be completely lightproof.

6.4 **Finishing Coats**

The finishing coats of pigmented butyrate dope may now be sprayed on. The number of coats will be determined as a balance between quality and cost but should not be less than three. A high gloss finish is obtained by lightly sanding each coat when dry and spraying multiple thin coats rather than several thick coats. The use of a retarder in the colour coats will allow the dope to flow out and form a smoother film. The final coat should be allowed to dry for at least a month before it is polished with rubbing compound and then waxed. The surface should be waxed at least once a year with a hard wax to reduce the possibility of oxidation of the finish.

7 **Application to Polyester-fibre Fabric**

Polyester-fibre fabrics are being increasingly widely used for covering aircraft because of their long life and resistance to deterioration. For this reason it is extremely important that the dope film is of the highest quality so that its life will match that of the fabric.

7.1 **Priming Coats**

Tautening of the fabric cover is not a function of the dope film where synthetic fabrics are used, although all dopes will tauten to some extent. Polyester-fibre fabrics are heat shrunk when the structure is covered. The most notable difference in doping a synthetic cover is the difficulty, when compared with natural fabrics, of obtaining a good mechanical bond between the dope and the fibres of the material. Unlike natural fibres the polyester filaments are not wet by the dope and the security of attachment depends upon them being totally encapsulated by the first coat of dope. The first coat must be nitrate dope thinned in the ratio of two or three parts of dope to one part of thinners. This coat is then brushed into the fabric in order to completely encapsulate every fibre. The dope should form a wet film on the inside of the cover but it should not be so wet that it drips through to the opposite side of the structure. The initial coat should be followed by two more brush coats of nitrate dope thinned to an easy brushing consistency. Certain additives are approved by the material manufacturer for use with the first coat for improving adhesion to the fabric. However, since polyester is not organic, there is no need for a fungicide to be added to the first coat of dope.

7.2 **Filling Coats**

Taping and attaching of drainage eyelets or grommets and inspection rings follows the same procedure as for natural fabrics. The priming coats should be followed by

spraying two fullbodied cross-coats of clear butyrate dope. After these coats have completely dried they should be lightly sanded (400 grit) and cleaned thoroughly with a tack rag. One full cross-coat of aluminium dope should then be sprayed on and lightly wet sanded when dry, the residue being rinsed off with water. This coat should be tested to verify that it is lightproof by shining a light inside the structure.

7.3 **Finishing Coats**

The finishing coats should now be applied in the same manner as for natural fabrics. It should be noted that with a properly finished polyester cover the weave of the fabric will still show through the dope film. Because the fibres are continually moving, any attempt to completely hide them will result in a finish that does not have sufficient flexibility to resist cracking.

8 **Application to Glass-fibre Fabric**

Glass-fibre fabric has a loose weave which tends to make it difficult to apply to aircraft structures. To overcome this problem it is pre-treated with butyrate dope and the covering and doping must be carried out in accordance with the manufacturer's installation instructions.

8.1 **Priming Coats**

Nitrate dope must not be used under any circumstances with this type of fabric. The first coat of clear butyrate dope is sprayed on with the dope being thinned only enough to permit proper atomisation. The atomising pressure must be set to the lowest possible that will permit proper atomisation without the dope being blown through the fabric. The coat should be heavy enough to thoroughly wet the fabric and soften the dope in the fabric, but must not be so heavy that it causes the dope to run on the reverse side of the fabric. If the dope is allowed to run in this way an orange peel finish will develop and the fabric will not tauten properly.

8.2 After the first coat has dried, further coats of butyrate dope should be sprayed on, each a little heavier than the one before it, until the weave fills and the fabric tautens; this may take as many as five coats. Tapes, drainage eyelets or grommets and inspection rings are applied in a coat of butyrate dope.

8.3 **Filling Coats**

Once the fabric is taut and the weave has been filled, two full-bodied brush coats of clear butyrate dope should be applied and allowed to dry thoroughly. The film should then be very carefully sanded, making sure that it is not sanded through to the fabric. Whilst the fabric is not damaged by ultra-violet radiation, the clear dope can deteriorate as a result of exposure and therefore, a coat of aluminium dope should be sprayed on for protection and lightly wet-sanded smooth. After the aluminium dope has been sanded, the residue should be removed by washing with water and then the surface thoroughly dried.

8.4 **Finishing Coats**

The application of the finishing coats is carried out in the same manner as for natural fabrics. Several thin, wet coats of coloured butyrate dope will allow the surface to flow out to a glossy finish.

9 Doping Problems

The production of a doped finish that is both sound and attractive is dependent upon a great deal of care and attention being paid to detail at each stage of the finishing process. In spite of this, problems do occur and the following paragraphs detail some common ones and their possible causes.

9.1 Adhesion

There are two basic areas in which adhesion may be poor; between the fabric and the first coat of dope and between the aluminium coat and subsequent coats. Adhesion to the fabric, particularly polyester fabric, is largely dependent upon the technique used to ensure the encapsulation of the fibres. Adhesion to the aluminium coat may be impaired if too much aluminium powder was used or if the surface was not thoroughly cleaned after sanding. The use of a tack rag to finally clean a surface before applying the next coat is always recommended.

9.2 Blushing

Blushing is a white or greyish cast that forms on a doped surface. If the humidity of the air is too high, or if the solvents evaporate too quickly, the temperature of the surface drops below the dew-point of the air and moisture condenses on the surface. This water causes the nitrocellulose to precipitate out. Moisture in the spray system or on the surface can also cause blushing. Blushing can be controlled by reducing the humidity in the air (raising the temperature by several degrees may achieve this) or by using a retarder in the place of some of the thinners. A blushed area can be salvaged by spraying another coat over the area using a retarder instead of some of the thinners; the solvents attack the surface and cause it to flow out.

9.3 Bubbles or Blisters

Bubbles or Blisters are caused by the surface of the dope drying before all the solvents have had time to evaporate. This may happen if a heavy coat of dope is applied over a previous coat that had not fully dried.

9.4 Dull Finish

The gloss of butyrate dope may be improved by the addition of up to 20% retarder in the last coat. Excessive dullness may be caused by holding the spray gun too far from the surface so that the dope settles as a semi-dry mist. Small dull spots may be due to a porous surface under the area.

9.5 Fisheyes

These are isolated areas which have not dried due to contamination of the surface with oil, wax or a silicone product. Cleanliness is important, especially when refinishing a repair. All wax should be removed using a suitable solvent before attempting to re-dope the surface.

9.6 Orange Peel

This is caused by insufficient thinning of the dope or holding the spray gun too far from the surface. It can also be caused by too high an atomising pressure, use of thinners that is too fast drying or by a cold, damp draught over the surface.

9.7 Pinholes

These are smaller versions of a blister. Apart from the causes listed in paragraph 9.3, they can be caused by water or oil in the spray system. An air temperature that is too high can also be a cause.

9.8 **Roping**

This is a condition in which the surface dries as the dope is being brushed, resulting in an uneven surface. This is common when the dope is cold and has not been brought up to the temperature of the spray shop. When applying dope with a brush, it should not be overbrushed. The brush should be filled with dope then stroked across the surface and lifted off. The pressure applied to the brush should be sufficient to ensure the proper penetration of the dope.

9.9 **Rough Finish**

Dirt and dust on the surface, insufficient sanding and too low a working temperature can all cause a rough finish.

9.10 **Runs and Sags**

This type of defect is caused by too thick a coat, especially on vertical surfaces. This can be the result of incorrectly adjusted spray equipment or incorrect technique.

9.11 **Wet Areas**

This is a larger version of the defect described in paragraph 9.5.

10 **General Considerations**

- 10.1 The weight of the dope applied to the fabric is an indication that the scheme has been correctly applied. In the BS X26 doping schemes the weight per unit area is given and should be checked by doping a test panel at the same time as the structure. The fabric is weighed before doping and then again after doping, the difference being the weight of the dope film. United States Military Specifications call for a minimum dope weight of 161 g/m^2 (4.75 oz/yd^2). A tolerance of $\pm 20\%$ may be applied to the weights given in BS X26.
- 10.2 When an aircraft is re-covered and re-doped it is essential that it is re-weighed and a new Weight Schedule raised (see Leaflet 8-10).
- 10.3 After the re-covering, repair and doping of control surfaces it is essential that the static balance of each surface is checked against the manufacturer's requirements. Addition of weight aft of the hinge line without correction of the static balance is likely to cause flutter of the control surface.

Leaflet 51-170 Inspection of Composite Structures

1 Introduction

This leaflet provides general guidance for the inspection of composite aircraft structure (including repaired structure) for which no, or incomplete, manufacturer instruction exists.

The term 'composite structure' generally refers to structure manufactured from a very broad band of material types when used in aerospace applications, e.g. metal alloys, metallic honeycomb sandwich structure, fibre reinforced non-metallic matrix systems etc. For the purposes of this leaflet the term 'composite structure' refers to both monolithic and sandwich structures manufactured from fibre reinforced non-metallic matrix systems, e.g. Glass Fibre Reinforced Plastic (GFRP or GRP), Carbon Fibre Reinforced Plastic (CFRP) etc. Inspection guidance for metallic composite structure may be considered to have been given in part by CAP 562, Leaflet 51-50.

2 General

The use of composite materials has increased significantly during recent years, developing from simple minor structural applications, e.g. wing tip fairings (e.g. Cessna C172), to use in significant sections of Primary Structure, e.g. fuselage and wings (e.g. Europa and many gliders) to complete airframes (e.g. T67 and Grob 115). Therefore, inspector familiarity with these materials, and the significance and nature of any damage, has become increasingly important.

Composite materials comprise of more than one constituent material (inhomogenous), and exhibit net properties that differ from those of any one of the constituent materials. Such a composition tends to provide properties that vary with direction (anisotropic). These properties, when correctly engineered, provide for the often quoted benefits of composite materials, e.g. high stiffness to weight and strength to weight ratios etc. However, these properties also provide for the possibility of more types of damage than would be found in metallic structure, and each type of damage may carry a particular significance to the structure. Therefore, it becomes necessary for the inspector to be aware of these damage types, although composite structure is usually designed such that the same level of predominately visual inspection required for metallic structure will also be required for composite structure to ensure that safety is maintained, i.e. any damage that may remain undetected visually will not propagate between inspections to threaten ultimate load capability and fatigue life.

Structural deterioration may arise from various causes, e.g. wear and tear, load, environment etc, and can affect various parts of the structure according to the design of the aircraft and the use to which it is put. Therefore, this leaflet should be read in conjunction with the appropriate manufacturer's publications and Maintenance Schedule for the aircraft concerned.

Although considerable guidance may be given in the appropriate publications as to suitable opportunities for inspecting normally inaccessible structures, experience should indicate to the operator further opportunities for such inspections which can be included in the Maintenance Schedule, e.g. when the wing tip is removed permitting access to the adjacent wing structure etc.

Furthermore, whenever unscheduled access has been gained to a part of the structure which is normally inaccessible, then advantage should also be taken of this dismantling to inspect all parts of the structure exposed. The need to exploit such opportunities for inspection will be more prevalent to composite structures, than to metallic structure, due to the possibilities of significant Barely Visible Damage (BVD) and externally Non-Visible Damage (NVD). Apart from the airworthiness aspects, these combined inspections could often be to the operators advantage, since they may obviate the need for future dismantling. Furthermore, damage may be detected at an earlier stage of development requiring a smaller, and less costly, repair.

3 Cleanliness

The propensity for composites to suffer BVD and NVD requires the use of effective cleaning processes prior to inspection. A clean paint surface could make the difference between locating BVD and not, i.e. NVD, e.g. when non-penetrating impact occurs. Subtle changes in light reflection can be the determining factor.

Composite materials, and the associated protective treatments, e.g. paint, gel coats, etc., may react in significantly different ways from one material system to the next when exposed to various cleaning agents and techniques. These reactions may also differ from those more frequently experienced by operators familiar with metallic structure and any of the associated surface treatments. Therefore, it is important that manufacturer's guidance is obtained regarding cleaning materials and methods prior to the start of the cleaning process. However, a generic cleaning procedure applicable to common composite material structure may comprise of:

- 3.1 **Gaining access** (see also CAP 562, Leaflet 51-50): This includes removal of all acoustic liners, thermal blankets etc., such that all surfaces can be made visible in adequate lighting, either directly or with the aid of suitable inspection devices, such as mirrors or boroscopes. Note that particular care is required when handling and accessing composite structures, e.g. removing panels, placing body weight on surfaces, tool handling etc., because this type of structure is vulnerable to damage resulting from such activity, particularly the control surfaces and trailing edges. Protective equipment such as mats and crawling boards should always be used when, and in accordance with, instructions specified by the aircraft manufacturer.
- 3.2 **Removal of obvious debris, loose paint, dirt etc.:** Loose paint should be removed with care to avoid damage to the composite surface. This may be achieved by hand sanding, e.g. using Grade 320 paper. Note that a primer paint of contrasting colour may have been used to mark the surface of the structural laminate. Any sanding beyond the primer layer will damage the fibres and matrix. The manufacturer should be consulted for guidance if large areas of paint are to be stripped. Blasting, e.g. Plastic Media Blasting etc, or chemical stripping methods should be considered to be unacceptable unless specifically permitted by the manufacturer. Most blasting media will damage the composite outer fibre and matrix layer, whilst the constituent materials in paint stripper, e.g. Methylene Chloride, can be particularly damaging to the matrix.
- 3.3 **Initial visual inspection:** There should be a preliminary inspection of all surfaces, edges, and joints and is intended to provide an approximate indication of the nature and extent of any damage. Typical defects which may be detected at this stage include cracks, holes, gouges, dents, edge delaminations, fastener hole damage, severe burns, and sealant damage. A careful initial inspection may allow for an earlier, and therefore less costly, 'scrap' decision to be made without wasting time and effort completing any further work.

- 3.4 **Cleaning:** Cleaning may be achieved simply by wiping the surface using a cloth moistened with a suitable degreasing agent, e.g. Methyl Ethyl Keytone (MEK), Isopropyl Alcohol (IPA) etc. A clean cloth should be used for each application of agent and for each removal of excess fluid and dirt respectively. Should a more thorough clean be required, e.g. using a mild detergent and water, then masking will be necessary to prevent further damage from cleaning agent ingress at the damage site. Masking should be completed using a compatible tape. The cleaning agent should be applied with a sponge, cloth, or similar non-metallic means of application, i.e. that which will not damage the surface. The structure may be rinsed using clean water. High pressure hot water jets, or steam, should not be used. The structure may be dried using a clean dry cloth. Drying can be accelerated using a clean dry compressed airflow. Typically this may be at temperatures up to 50°C for most materials that have been cured at elevated temperature. However, materials cured at room temperature (without elevated temperature post cure) should be treated with caution at lower temperatures, e.g. 30°C maximum.

All drain paths and drainage holes should be checked to ensure that they are clear of debris once cleaning has been completed.

- 3.5 **Visual inspection:** see Section 4.

The sequence above may form the preliminary stage of a repair action should defects be found.

4 Inspection Methods

Approximately 90% of all aviation inspections of composite structure are visual, often being complemented by a Tap Test. Many other inspection techniques are used by the aviation industry, e.g. Dye Penetrants, Bond Testers, Ultrasonic Inspection, Radiography, Mechanical Impedance, and Thermography. However, these methods tend to be used more by manufacturing industry and public transport operators, than by small aircraft operators, due to the relatively high cost of installation and operation. These techniques are often only used following the visual location of damage, or suspected damage. Details regarding these methods are available in many texts, and will only be briefly mentioned (Appendix 1) because they generally fall outside the scope of this Leaflet. Furthermore, Non-Destructive Inspection and Testing (NDI and NDT) are the subject of extensive research activity and consequently the material in this Leaflet does not attempt to be a comprehensive coverage of NDI and NDT.

All inspections must be completed by suitably qualified personnel, e.g. see CAP 747 Mandatory Requirements for Airworthiness Generic Requirement (GR) No. 23.

- 4.1 **Visual Inspection:** Some composite damage can be located by visual inspection, whilst some may not. Inspection may be complicated by the material surface finish. The material may remain in its natural finished state, it may have been finished with a dye, it may have a gel coat (possibly coloured), or it may have been painted. Paint colour may be significant to damage detectability. These conditions should be allowed for when completing inspection. Furthermore, knowledge of the surface material type, e.g. the type of weave etc, will help identify the existence of damage. Note that it is common for a manufacturer to use a sacrificial protective woven outer layer to protect the structural plies, particularly unidirectional plies. This may give a false impression of the structural build. Manufacturer's data, e.g. repair manuals, drawings etc, should be consulted to establish this point. If in doubt, then treat the outer ply as a structural ply.

Visual inspection may allow for the detection of many defect types, e.g. some impacts, delaminations, disbonds, cracks, some heat damage, 2.54mm (0.1in.) depth, scratches of 1.27mm (0.05in.) length etc. Lesser dimensions may be located in favourable conditions. The nature and extent of damage that may be detected may vary significantly, being a function of many variables, e.g. cleanliness, lighting, inspector skill and experience, surface finish, colour etc.

All visual inspections should be completed in adequate lighting, and at such a distance, that an inspector may be confident of locating damage as identified in Section 5. Manufacturer's instruction should be followed regarding the distance from the structure that an inspection should be completed because the nature and extent of inspectable damage should be a function of the design. Typically, a visual inspection should be completed at a distance no greater than 1.52m (5ft.) from the structure, whilst a detailed visual inspection should be completed at whatever lesser distance, e.g. typically 0.2-0.3m (8-12ins), allows confirmation of the existence, nature, and extent of any damage. This may be complemented using a 10X magnifying glass. Obviously, any suspicion of damage, or previous experience of damage at any given location, requires a detailed visual inspection and may require further disassembly. Particular attention should be paid to previous repair locations. Extensive disassembly may require aircraft jacking. Jacking should be completed in accordance with manufacturer's instruction.

The inspections may be completed with suitable inspection devices, such as mirrors, light probes and boroscopes, ref. CAP 562, Leaflet 51-50 Section 8 and Leaflet F-90.

Once located, the significance of the damage should be assessed, e.g. as being cosmetic or structural damage, see Section 5.

Note that visual inspection will not be adequate to allow detection of some damage types i.e. NVD, e.g. some delaminations, impacts, and heat damage etc. The design should allow for this, or further actions should be called in the manufacturer's data to deal with potential problems. Furthermore, note that some damaged structure may relax, e.g. impact damage, to the extent that 60%, or more, of the original profile may be recovered. Therefore, the time between a damage event and inspection may be significant to detectability.

- 4.2 **Light Test:** Delamination in GFRP components that do not have rigid foam, or any similar obstructions inside, can often be detected by pointing a bright light at the surface whilst looking at the other side. Damage may be evident as a dark area. Care must be taken in positioning the light source so as not to let the composite get hot, as this can cause damage. CFRP does not allow for such inspection. This is an inspection method widely used and recommended by manufacturers such as Grob and Slingsby.
- 4.3 **Tap Test:** In its crudest form the Tap Test is the simple tapping of the structure with a coin, or similar small hard blunt object, such that a sound is generated. A damaged structure usually produces a 'duller' sound than an undamaged structure. Although crude, the Tap Test can be a useful complimentary tool for a visual inspection, particularly when confirming the presence and approximate dimensions of disbonds and delaminations. It may be possible to detect such defects down to 12.7-25.7mm (0.5-1in.) diameter in typical composite manufactures. A structure should be explored in 6-13mm (0.25 – 0.5in.) steps to locate such damage. Note that the minimum detectable dimension increases with material thickness. The usefulness of the Tap Test for sandwich structure is limited to damage detection at the presented face, e.g. inter-ply delamination or core to skin disbond. Significant honeycomb cell fluid content may sometimes be detected. Unfortunately, the sound will also change due to factors other than damage, e.g. changes of thickness, hidden attached structure,

potting material, the presence of repairs etc. Therefore, knowledge of the composite structure, and the surrounding structure, is necessary to gain the most useful information from the Tap Test. Furthermore, a Tap Test is difficult to use reliably over large areas because an inspector may experience problems maintaining concentration during such a repetitive task.

Note that automated electronic Tap Test equipment is available which measures impact signal transmission duration or frequency.

5 Damage

The significance of composite damage is dependent upon the function of the structure and the type and extent of damage. The most likely cause of damage, approximately 80%, is impact, often the result of ground handling. This may produce one, or more, of the damage types identified below. The most significant damage types are delamination, disbond and material penetration. The significance of the extent of damage is a function of the design. Reference should be made to manufacturer's data regarding this issue.

- 5.1 **Structural Function:** The function of the structure depends upon the design. However, it is common for structure to be categorised as Primary Structure or lesser structure, e.g. Secondary Structure. Primary Structure is that which, if damaged, could threaten the structural integrity of the aircraft, e.g. wing spars, skins, ribs, ailerons, etc, or fuselage skins, stringers, etc, or tail structure, elevators, rudders, etc. Secondary Structure is that which may pose a significantly lower safety risk and/or be associated with an economic cost, e.g. wing/body fairings, nacelles etc. The categorisation may not always be clear, e.g. a fairing may initially appear to be Secondary Structure, but could, upon separation, threaten the safety of the aircraft by impact with Primary Structure. If in doubt, such structure should be treated as Primary Structure. Furthermore, the categorisation may be extended to distinguish between sections of any individual component, e.g. a flap may be 'zoned' such that structure adjacent to hinge attachments is considered to be more critical than the field areas, thus requiring more stringent allowable damage limits to be applied to the former. The inspector should use manufacturer's guidance to clarify the function of the structure. This is particularly important for smaller aircraft designs because they tend to use a wider range of configurations than larger public transport aircraft.
- 5.2 **Types of Damage:** The type of structural damage, be it to Primary or lesser structure, may be categorised as **cosmetic** or **structural**.
- 5.2.1 **Cosmetic Damage:** Cosmetic damage is that which is of no immediate structural concern. However, cosmetic damage that could allow fluid ingress should be repaired, i.e. dried and sealed, to prevent it from progressing to become structural damage.

Wrinkling and Dimpling: Minor skin wrinkles and dimpling (sandwich panel skin wrinkling that adapts to the shape of the honeycomb cells, which should not be present if the part has been correctly designed with small honeycomb cells), Figures 1 and 2, may have been present since manufacture. Defects present from manufacture may be distinguished from damage by careful inspection for other evidence of degradation, e.g. surface crazing, fibre breakout, loose resin material, delamination etc. However, if in doubt, such structure should be Tap Tested for delamination to ensure that any apparent 'wrinkling and dimpling' is not the result of skin buckling, i.e. damage which is of structural interest.

Resin Rich and Resin Starved Areas: Porosity in resin rich areas, or exposed fibre in resin starved areas, Figures 3 and 4, should be obvious and must be dried and sealed to prevent long term degradation due to fluid ingress.

Surface Damage: Many structures use a sacrificial outer ply layer, e.g. a woven glass ply, to resist 'wear and tear' or to help prevent unidirectional fibre break out. The manufacturer's drawings should be referenced to avoid the incorrect determination of the significance of any surface ply damage. If any doubt exists regarding the function of the outer ply, then it should be treated as a structural ply and repaired accordingly. Damage to a sacrificial layer, although of no immediate concern, may allow fluid access to the main structure. Again, such damage should be dried and sealed.

5.2.2 **Structural Damage:** Structural damage is that which threatens the function of the structure, whether it be damage to Primary or lesser structure.

Composite structural damage may be further categorised as being **penetration damage**, damage between plies (**inter-ply damage**), or damage to the constituent materials (**intra-ply damage**), e.g. matrix or fibre damage. Sandwich structure adds further possibilities, e.g. honeycomb damage or core to skin interface damage.

5.2.2.1 **Penetration Damage:** Any laminate penetration, e.g. holes resulting from impact damage etc, is a concern because it represents damage to both fibre and matrix material. Such damage is often self evident, although smaller holes may be missed and could allow long term moisture ingress to occur. This is particularly true for sandwich structure. Any penetrations should be repaired.

5.2.2.2 **Structural Inter-Ply Damage:** Damage between plies.

Delamination: Delamination, Figure 5, is the separation between plies in a laminate, i.e. in the plane of the laminate. It may run across the whole laminate, or it may run to the laminate edges, and/or it may occur between many plies in any single laminate.

Composite structure is often compression critical. Delamination may further reduce the compressive strength, both at the local fibre level and at the component buckling level. Furthermore, delamination is often BVD, or NVD, on the external face of the structure. Therefore, thorough inspection of clean structure and access to the internal face of the structure is essential if the chances of detecting potentially significant damage are to be maximised.

Delamination may sometimes be visible as cracking parallel to the fibres at the laminate edges. Any cracked paint and debris at laminate edges should be removed, using non-metallic scrappers etc, prior to inspection of the edge.

Delamination that is not visible may sometimes also be located by using a Tap Test, see above. The chances of finding hidden delamination are greatly increased by knowledge of an event, e.g. an impact, or by the presence of other damage. Any fibre break-out on the internal face of the structure is likely to be associated with delamination. Any clues that indicate the presence of delamination, e.g. dents, paint damage, deformations, should be followed by a Tap Test.

Inspection for delamination should include all laminate edges, cutouts, and any opened fastener holes. Delamination resulting from poor fastener hole fit, wear and tear, poor drilling, or excessive fastener pull-up load is common.

Disbond: Disbond is the separation between laminates, e.g. a bonded joint, or the separation of a laminate skin from honeycomb core material, see 'Sandwich Structure Damage' paragraph 5.2.2.4.

Early detection of disbond is important because it may provide an indication of imminent joint failure. Obviously, this may be critical for any bonded Primary Structural joints that do not have secondary fastening. It should be noted that the progression from the initial areas of disbond to catastrophic failure may be very rapid. The progression may be accelerated by moisture ingress or fatigue loading at the joint.

Disbond may be evident as a gap in the adhesive line at the joint section edge, Figure 6, if accessible, or as ply peeling and/or paint damage along the joint edge when viewed perpendicular to the presented face. Disbond may sometimes be detected by using a Tap Test. Again, as with delamination, a 'duller' sound will be produced at the damage site than in the surrounding structure. However, interpretation may be difficult due to changes in section at the joint, varied back-up structure, and the presence of other joints.

Inspection of the disbond initiation surface, if visible, may help determine the potential severity of a problem. Correctly designed, the joint should fail in the adherend, i.e. the materials being joined together, because the joint should be stronger than the parent material. Such a failure, i.e. 'cohesive failure', will be evident as fractured matrix material and exposed and/or damaged fibres extending beyond the adhesive line into the adherend material. Such a failure is an indication of an overload. A more thorough inspection of the aircraft structure should be initiated, e.g. a 'heavy landing' inspection, unless the damage is the result of a known local event.

The disbond may be the result of a failure in the adhesive material, i.e. 'adhesive failure'. Fractured adhesive material may appear, probably without exposed fibres, to be paler in colour than the undamaged adhesive. Such a failure is an indication of an under strength adhesive.

The disbond may be the result of poor bonding between the adhesive and the adherend. This may appear as smooth unbroken adhesive and adherend surfaces without fibre exposure. Such a failure is potentially catastrophic because it may be the result of the adherend joint surfaces being contaminated. Such a contamination is very likely to have effected most, if not all, of a joint. Unlike an overload of a fully bonded joint, the material that has not already disbanded at the time of a finding is very likely to be poorly bonded. Such a finding must be followed by repair action that will recover full strength to the whole of the joint unless it can be shown that the remaining joint is at full strength, e.g. a small disbanded area is the result of a known local contamination.

5.2.2.3 **Structural Intra-Ply Damage:** Damage to the constituent materials.

Fibre Damage: Composite material fibres carry the laminate load via shear transfer from the matrix material. Therefore, the failure of any fibres may be significant to the strength of the part, particularly when tensile loads are parallel to the major fibre direction.

Fibre failure may be visibly evident as fibre breakout, Figure 7. The form of the fibre breakout will depend upon the fibre arrangement in the material, e.g. unidirectional, woven etc, and the strength of the fibre-matrix bond. Unidirectional material may often produce long fibre filament breakout, whilst woven materials, e.g. aramids, often result in fibre tufts standing proud of the surface. Such breakout may be evident across the material surface, along the structure edges, at cut-outs, or in fastener holes. Those composite systems with weak fibre-matrix bonding, e.g. aramids, tend to produce more loose fibre and tufts, when damaged, than may be evident in a system with a strong fibre matrix bond. The latter may result in a cleaner brittle failure. Such damage may be associated with extensive delamination. Fibre breakout is often

the result of impact damage, poor handling, or poor drilling, and is more likely to be evident on the back face of the structure. Any fibre damage, particularly that to primary structure, must be repaired immediately.

Matrix Damage: Matrix material allows the transfer of load to and between fibres. Therefore, matrix material damage is potentially very serious. The failure of the matrix material may be particularly significant to the shear and compressive strengths, and stiffness, of a structure.

The matrix may be damaged by direct overload or by exposure to the environment, e.g. heat, moisture etc. The properties may be altered at the time of exposure to the environment and/or altered when exposed for a period of time. The alteration may be reversible or irreversible.

Heat Damage: Heat may soften the matrix such that shear and compressive strengths and stiffness are significantly reduced. If the heat is excessive, i.e. the glass transition temperature range (the temperature range over which a reversible change from brittle to rubbery state occurs) is exceeded, then irreversible damage may occur as the matrix breaks down (typically at a temperature above the cure temperature).

Heat damage may be evident as obviously burned and discoloured matrix material. However, other clues should also be used as indicators of heat damage because exposure to lesser heat may not discolour the matrix. Such clues include knowledge of any events, e.g. exposure to engine heat, blistered and discoloured paint, or gel coat damage etc.

Lightning Strike Damage: Lightning strike damage is a particularly severe form of heat damage which may be evident, assuming that total destruction has not occurred, as distinct 'pin-hole' burns at the lightning contact points, extensive damage (any and all types) remote from the contact point, e.g. delamination, and severe burns at junctions with metallic structure. Further clues may include damage to any attached conductive paths, e.g. aluminium 'window frames', or missing static wicks. The extremities of an aircraft are particularly vulnerable to lightning damage, e.g. wing tips, fins, control surfaces etc.

It should be noted that discoloration may not define the full extent of the matrix damage. It may be necessary to trim an additional margin from the cut-out area, e.g. 25-55mm (1-2 in.), to clear damaged matrix material that has exceeded the glass transition temperature, but which has not visibly burned. Alternatively, it may be possible to define the damage boundary by careful grinding of the trimmed cut-out edges until a change in texture is experienced. This process requires skill and judgement.

Any inspection for lightning damage should include a check of all electrical paths and contacts, including static discharge wicks, aluminium flame sprayed surfaces etc. It is essential that the integrity of the protection systems are maintained. Manufacturers tend to recommend the use of bond testers to check that the resistance of the system remains in limits.

Fluid Ingress: Fluid ingress may refer to both the uptake of fluid by the matrix or the uptake of free standing fluid, the latter being a particular problem with sandwich structure, see paragraph 5.2.2.4. Fluid ingress may degrade the matrix material resulting in strength reduction which, again, can be particularly significant for structure subject to shear and compressive loads. The extent of degradation will vary from one fluid to the next. Fluid, if not removed from the part, may make repair impossible due to part destruction if the repair cure temperature exceeds the fluid boiling point.

Fluid ingress may not be very obvious. However, any evidence of protective layer damage, e.g. to the paint, should raise suspicions and require that any subsequent repair action be preceded by drying action, see Section 3.4.

Heat and moisture combined may further enhance the degradation of the properties of a composite. Compressive and shear properties are lowest in the 'hot and wet' condition, e.g. a carbon epoxy system, 0-6% moisture content, may show 10-15% compressive strength reductions between room temperature and 50°C. Tensile properties are lowest in the cold and dry condition, e.g. a carbon epoxy system may show 5-10% tensile strength reduction between room temperature and -56°C.

Matrix Cracking: Matrix cracking may often be the first visible indication of potentially significant damage, e.g. it may be associated with delamination and may be evident at the laminate edge as regularly pitched cracks transverse to the major load direction. It may also be evident as surface crazing over the plan surface areas. The latter is more common to woven materials.

Porosity: Porosity, Figure 8, may allow fluid ingress and result in material degradation. It may be evident as local surface pitting. Severe internal porosity may sometimes be located using a Tap Test. The existence of porosity may also indicate that the local structure has excess resin or that a local repair exists. Porosity should be dried and sealed. However, severe porosity requires a more substantial repair.

Fibre-Matrix Disbond: A laminate manufactured from predominately unidirectional plies in many orientations may split parallel to fibres in some of the plies as the fibre disbonds from the matrix. This is typical of unidirectional CFRP and may not be too significant if the splitting occurs in a small number of plies laying perpendicular to the load direction. However, splitting may have a significant effect upon the stiffness and compressive strength in some designs, particularly those subject to bi-axial loading.

Such damage may be evident as cracking in the damaged plies at the laminate edge or as fibre breakout from the presented face. However, it should be noted that many designs avoid the use of unidirectional materials in the outer plies, thus reducing the opportunity of detecting such damage.

5.2.2.4 **Sandwich Structure Damage:** Sandwich structure comprises of a honeycomb, or foam, core sandwiched between skins.

The skins are thin laminates which have a similar function to that of an 'I-Beam' cap, i.e. resists bending. The core has a function similar to that of an 'I-Beam' web, i.e. resists shear, and also crushing loads. Therefore, the effects of damage can be considered accordingly.

Skin Damage: The laminate skins may suffer similar damage to that already described, e.g. delamination and disbond. However, the limited thickness, e.g. typical 3 or 5 plies, of the skins increases the likelihood of, and therefore importance of, detecting skin penetration because these damages allow access for free standing fluid to the cell structure of the core. Similarly, skin-core disbond at sandwich structure edges, Figure 9, may allow fluid ingress. A considerable amount of fluid may accumulate, Figure 10, creating weight and balance problems for control surfaces. Furthermore, the accumulated fluid may freeze, expand, and further damage the part. Any attempt to repair the part without drying will also be futile if the cure temperature is greater than the boiling point of the fluid. Total destruction of the part is likely.

Fluid ingress may sometimes be detected using a Tap Test, if the mass of free standing fluid is adequate to alter the sound transmission qualities of the structure. A Tap Test may also be used to detect near side skin-core disbond away from the edges of the structure.

Core Damage: Core damage is often obvious, e.g. Core Depression, Lateral Core Crushing, Figure 11, Skin Bulging, Dents etc. However, the skin may disbond from the crushed core and recover the original structural profile. Therefore, any suspicion of impact on a sandwich structure, e.g. missing paint, scratches, etc, should be followed by a Tap Test. Any damage should be dried and repaired.

5.2.2.5 Structural Damage Causes:

The above text identifies the majority of the basic damage types that may be experienced by composite structure. However, such damages may appear in many permutations depending upon the cause. Some causes have particular characteristics which are identified below, (other than impact which has already been mentioned).

Overload: This occurs if any of the primary failure strengths e.g. tensile, compressive, shear etc., are exceeded. Failure may also occur without exceeding any one of the primary strengths due to the interaction of stresses. The nature of the damage, e.g. fibre failure, delamination, matrix cracking etc, will depend upon the strength(s) exceeded. When failure occurs without exceeding any one of the primary strengths, damage may be evident as delamination because the stress interactions often result in out of plane stresses which exceed the out of plane strength (not normally considered a primary strength in many designs).

Fatigue: Contrary to popular belief, composite materials may suffer fatigue damage, particularly when damaged and exposed to the environment. Damage may also be evident as many permutations of the damage types identified in this leaflet. Fatigue damage is often evident throughout the life of the structure. Typically, damage may progress from initial transverse fibre-matrix disbond through intra-ply matrix cracking, inter-ply matrix cracking, delamination, and fibre failure. Engineering properties, e.g. stiffness and strength, reduce during this progression. This contrasts with metallic structure, which typically only shows evidence of fatigue damage during the final 5% of its life. Fastener locations in composite structure are particularly vulnerable to fatigue damage. Loose fasteners result in delamination, hole deformation, and sometimes heat damage. Note that composite structure failed in fatigue tends to show significantly more damage than a structure failed by comparable pseudo-static overload, e.g. typically up to ten times the number of damage sites. Knowledge of the existence of a fatigue environment and the above damage sequence should draw the inspector's attention to the damage types identified and help the determination of damage significance. Again, any damage that is not obviously cosmetic requires immediate repair.

Lightning Strike Damage: Composite materials do not tend to be good conductors and consequently the energy from a lightning strike may be dissipated via complete, or partial, destruction of the part. Any combination of damage types identified above may be evident, but typically include obvious burns, various permutations of heat damage, and extensive delamination, see Section 5.2.2.3 above.

Wear and Tear: 'Wear and Tear' refers to general degradation such as fastener hole bearing damage, often the result of repeated panel removals, erosion of leading edges, minor ground handling damage, including abrasions, gouges, nicks and scratches etc. The significance of the damage must be assessed on a case by case basis and repaired accordingly. Such damage are usually self evident on a cleaned surface.

Ultra-Violet (UV) Radiation: Although not usually directly visible, UV damage may be evident through other damage types, e.g. matrix surface crazing, gel coat crazing etc. (note that some gel coats are partly intended to protect the composite from UV). UV damage reduces the engineering properties of the matrix material and makes it

more vulnerable to load, the environment etc. Many of the older matrix systems are vulnerable to UV damage as are Aramid fibres. The damage severity increases with time exposure and altitude flown. Again, such damage should be repaired. Note that more recent matrix systems are more resistant to UV damage.

Abrasions, Gouges, Nicks, and Scratches: These may be of structural concern if fibres have been broken, particularly those parallel to the major load direction, or if a path for fluid ingress has been provided.

Existing Repairs: Repairs are structural discontinuities and will tend to provide unsymmetrical and unbalanced structure, thus making them a likely source of problems, e.g. repair ply peeling and delamination. Repairs tend to be more porous than the surrounding original structure.

Repair locations are usually obvious on unpainted structure, whilst the location of repairs on painted structure may be possible by careful visual inspection at a shallow angle to the clean surface. The identification of repairs may be eased by consulting the manufacturer's repair documentation which should provide some clues as to typical repair shapes, e.g. square, circular, etc, and typical repair styles, e.g. flush, scab doublers etc.

Obvious initial indications of degraded repairs include lifted paint and peeled repair doubler edges. Note that particular attention should be paid to recent repairs because a poor bond may well result in ply peeling, or possibly repair separation, within a short number of cycles.

A Tap Test may help to confirm the presence of a repair. Laminate repairs tend to have overlapped joint areas, additional plies, e.g. doublers etc, and increased porosity. Repaired sandwich structure tends to have extensive potting material around the repair boundary. These factors will alter the sonic response of the structure.

6 Repairs

Composite aircraft manufacturers may classify areas of the aircraft, usually Primary Structure, as non-repairable or no repairs permitted areas. These areas are usually detailed in the Maintenance Manual and/or the Flight Manual. If damage is located in these areas the manufacturer must be consulted immediately for advice. For areas where repairs are permitted the repair should be carried out strictly in accordance with the manufacturer's instructions and using approved data. Allowable repairs should be carried out only in a suitably clean environment where temperature and humidity controls can be maintained and using only the material specified in the approved data. Personnel carrying out repairs should be suitably qualified in composite repair techniques and be aware of the health hazards associated with working with resins, hardeners, solvents and composite material dust. Consideration should be given to the effect that the repair may have on aircraft Centre of Gravity limits. Repairs to composite flight control surfaces may require control surface balancing which should be accomplished strictly in accordance with the manufacturer's instructions.

Note that repairs may interfere with lightning protection systems. Ensure that any damaged or displaced systems are corrected in accordance with manufacturer's data.

7 Paint Finish

Manufacturers often specify colours and types of paint finish because composite materials, particularly older materials, are sensitive to heat and UV radiation damage.

Any change to aircraft paint scheme must be strictly in accordance with the manufacturer's instructions. Further information regarding paint schemes may be found in CAP 747, GR No. 10.

Appendix 1 Further NDT Techniques

Qualified Personnel: NDT inspection must be completed by suitably qualified personnel, CAA CAP 747 GR No. 23 provides some guidance in this matter.

Penetrants: Red dye-penetrant may be of limited use for surface damage detection in composite structure. Its use should be considered to be part of a destructive exploration of the part because the penetrant will be difficult, if not impossible, to remove and may contaminate and degrade the material. Furthermore, poorly finished surfaces may give rise to many false indications.

Bond Testers: Bond testers use ultrasonic signals to detect shifts in the through-thickness resonant frequency of a bonded joint to locate disbonds or poor cohesion. A coupling fluid is required.

Low frequency bond testers (<100kHz) operate by measuring the phase and amplitude of the signal returned from energy transmitted in a plate wave mode to determine the integrity, or otherwise, of the material. A coupling fluid is not required.

High frequency testers (25-500kHz) operate by passing narrow bandwidth standing ultrasonic wave signals into the material. Deviations in the measured resonant frequency indicate the presence of a defect. A coupling fluid is required. Materials may be inspected to a thickness of 0.5 in. Delaminations may be located down to 0.5in. diameter.

Ultrasonic Inspection: Ultrasonic inspection involves the detection of ultrasonic waves passed through the structure. The receiver may be on the opposite side of the structure to the transmitter, i.e. Through Transmission (TTU), or on the same side of the structure as the transmitter, i.e. Pulse Echo (PE).

TTU allows disbond, delamination, and crack detection in monolithic and sandwich structure. However, good access to both sides is required.

PE allows detection of similar damage in monolithic structure, but from one side of the structure. However, damage detection will be limited to the near face skins in sandwich structure. This technique is available in a portable form.

Ultrasonic inspection may be developed into a map of the part and its defects, i.e. C-Scan. The use of sophisticated processing and focused transceivers allows the development of the C-Scan into a three dimensional representation.

Radiography: Radiography is the passing of X-rays through a structure and the recording of the shadow from that structure onto film. The shadow is a function of part thickness, density, manufacture, and X-ray voltage.

Radiography may be useful for the detection of transverse cracking and fluid ingress (in sandwich structure).

Composites require low voltages due to the low material densities. The low difference in densities between constituent materials makes the contrast between materials, and contrast between material and damage, difficult. Penetrants may be used, but these tend to be unpleasant materials, e.g. Zinc Iodide, which cannot be removed from the composite. Furthermore, the structure may require working to get the penetrant to fully penetrate the damage. Other disadvantages include safety considerations, limited equipment access, cost, and the need for skilled interpretation.

Mechanical Impedance: This method uses changes in structural stiffness to detect damage, particularly disbond and delamination. The stiffness is a function of thickness, geometry, elastic variables and densities. The phase and amplitude of a transmitted sonic signal are

measured. This method may provide accurate determination of the extent of damage. Inaccuracies may result from incorrect receiver alignment, resonance, and noise from other equipment.

Thermography: This method relies upon the detection of thermal gradients, i.e. using IR radiation, to locate defects. The factors affecting the inspection include surface temperature, surface emittance, surface reflectance, background temperature, and the energy differential.

Thermography may be very useful for the detection of moisture ingress, particularly in sandwich structure. Unfortunately, an energy source is required to create the thermal gradient, e.g. the part may need to be removed from the aircraft and heated in an oven, or an engine run may be necessary, or immediate access to an aircraft upon return from a high altitude flight may be required. Furthermore, the equipment is expensive, knowledge of the structure is required, and interpretative skills are necessary.

Moisture Meters: These devices may be used to detect moisture in GRP and arimid material. They use the radio frequency dielectric power loss attributed to an increase in the conductivity of the composite, due to moisture absorption, to measure moisture content. This method of moisture detection cannot be used with conductive fibres, e.g. carbon, and cannot be used local to metallic structure, e.g. embedded conductive lightning protection grids may give false indications.

'Figures reprinted with permission from SAE document ARP5089 # 1996 Society of Automotive Engineers, Inc. A complete copy of ARP 5089 can be obtained from SAE, 400 Commonwealth Dr. Warrendale, PA 15096, phone: 724/776-4970, fax: 724/776-0790, E-mail: publications@sae.org.'

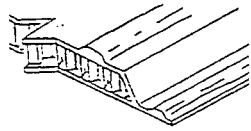

FIG.1 WRINKLED MATERIAL

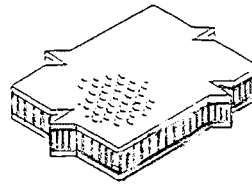

FIG.2 DIMPLING

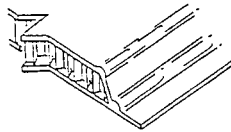

FIG.3 RESIN RICH MATERIAL

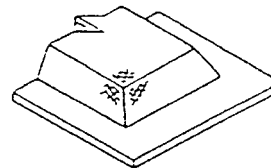

FIG.4 RESIN STARVED MATERIAL



FIG.5 DELAMINATION

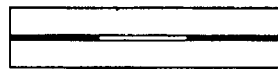

FIG.6 EDGE DELAMINATION



Fig.7 FIBRE BREAKOUT



FIG.8 POROSITY

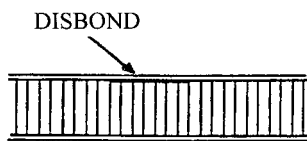

FIG.9 SKIN-CORE DISBOND



FIG.10 FLUID INGRESS

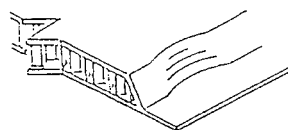

FIG.11 LATERAL CORE DENTING

INTENTIONALLY LEFT BLANK

Leaflet 51-180 Structural Attachment of Aerials

PURPOSE: This Leaflet provides information on the procedure to be adopted when fitting aerials to aeroplanes and helicopters.

REFERENCES: BCAR/JAR/FAR/CS Design and Construction Codes

Several instances have been reported of aircraft skin cracking as a result of inadequate reinforcement of structure following the fitting of blade type aerials. In one instance the cracking extended to include frame, stringer and doubler.

Installers must ensure when fitting aerials that adequate structural strength is provided. Where airframe manufacturer's modification schemes are not utilized, the extent of the structural substantiation necessary, should be discussed with the appropriate Regional Office Surveyor. Any changes to manufacturer's approval data will need to be addressed as a modification, which will be assessed by the CAA for Annex II aircraft or by EASA for EASA aircraft.

It should be noted that the aerials of different manufacturers vary in design and that together with the different aerial locations on the aircraft, varying mounting techniques will be required to ensure adequate structural strength is achieved.

INTENTIONALLY LEFT BLANK

Chapter 56 Windows

Leaflet 56-10 Glass Windscreen Assemblies

1 Introduction

This Leaflet gives guidance on the installation and maintenance of aircraft glass windscreen assemblies of both the simple and complex electrically heated type. As the assemblies fitted to different aircraft vary considerably, the information given in this Leaflet should be read in conjunction with the Maintenance Manuals and the approved Maintenance Schedule for the type of aircraft concerned. The CAA Requirements regarding tests on pressure panels are given in Chapter D3–7 and ACJ 25.775(d) of British Civil Airworthiness Requirements.

2 Glass

Glass is a hard, brittle material having the outstanding quality of transparency. To overcome brittleness but to leave transparency unimpaired is the main object of the manufacture of safety glass as used for aircraft windscreens. Examples of specifications which meet the requirements are DTD 218 Laminated Safety Glass, DTD 869 Laminated Safety Glass, High Light Transmission, DTD 761 Safety Glass Windscreen, Gyro Sight Quality and DTD 5576A Electrically Heated Laminated Safety Glass.

2.1 Characteristics of Glass

Glass, unlike metals, is non-crystalline. When heated or cooled it shows no sharp change in physical properties and has no definite melting point, but at about 600°C plate and sheet glass begin to flow under their own weight.

2.1.1 Glass may be broken by loading in various ways, e.g. impact, tension, twist, compression or shear and fracture will occur under any type of loading when deformation has produced the necessary tensile stress.

2.1.2 The breaking strength of glass is greatly influenced by five factors:

- a) Heat treatment (paragraph 2.2).
- b) Length of time of loading (paragraph 2.3).
- c) The rate of application of a load (paragraph 2.4).
- d) The condition of the surfaces and edges (paragraph 5).
- e) Method of installation (paragraph 3.2).

2.2 Heat Treatment

2.2.1 Annealing

After manufacture glass is cooled very slowly so that stress set up during the forming of the sheet may dissipate. If this were not the case, built-in tensile stress would weaken the glass to such an extent that it could break spontaneously. When glass of greater strength than annealed glass is required, a tempered glass is used.

2.2.2 **Tempered Glass**

The glass is heated to some point within the range in which it becomes soft and then the surfaces are quickly cooled by blasts of compressed air. This chills and hardens the outer surfaces whilst the inside is still hot and contracting, thus putting the outer 'skins' of the glass in a state of compression, resulting in a considerable increase in strength.

- a) The main drawback of tempering is that the glass will break up into tiny particles when fractured (the greater the degree of tempering the smaller will be the particle size) thus seriously obstructing vision.
- b) In the United Kingdom, glass which has been tempered to give maximum strength is termed 'toughened glass' (e.g. Type 1 of DTD 5576A). The term 'strengthened glass' (e.g. Type 2 of DTD 5576A) is used to indicate glass which has been tempered to a lesser degree than toughened glass. Although less strong than toughened glass it has the advantage of larger particle size should fracture occur.
- c) Because of the physical nature of tempered glass it cannot be filed, drilled or trimmed in any way, therefore any adjustments required during fitting must, of necessity, be done on the mounting frame. Great care is necessary when fitting the glass to prevent damage, for example chipping. Scratches, chips, flaws and other surface defects weaken glass very considerably and on this score alone every effort must be made to avoid such defects, particularly at the edges of the glass (see paragraph 5).

2.3 **Fatigue**

Cyclic fatigue of toughened glass at commonly used stress level, is effectively non-existent.

2.4 **Safety Factors**

The safety factors required on glass components are very much higher than for other materials used in aircraft manufacture, because of the loss of strength with duration of load, scatter in strength inherent in glass, thickness tolerances and high notch sensitivity.

3 **Windscreen Design**

The design of windscreens varies considerably according to the type of aircraft to which they are fitted, the extent of de-misting and impact strength required and also on whether an electrical method of anti-icing is to be used. The details given in the following paragraphs are of a general nature, outlining some design features of typical windscreen assemblies.

- 3.1 Windscreens are of laminated manufacture and in general can be considered as belonging to one of two categories,
 - a) the simple windscreen, usually fitted to non-pressurised aircraft having limited performance, and
 - b) the electrically-heated panel windscreen fitted to pressurised aircraft with all-weather capability.

3.1.1 **Simple Windscreens**

A panel is usually made up of two pre-formed and pre-tempered glass layers or plies, each of which is bonded to a sandwiched sheet or ply of reinforcing material termed the 'interlayer'. The suitability of a material for use as an interlayer depends on a

number of factors, the most important of which are its ability to withstand impact, to prevent breakage into dangerous fragments and to prevent detachment of such fragments from the inner surface of a panel. The material normally used for the interlayer is polyvinyl butyral (plasticised with dibutyl sebacate or triethylene glycol dehexoate), generally referred to as vinyl.

- a) The vinyl and glass layers are bonded by the application of pressure and heat, the temperature being considerably less than that required for tempering the glass and below the temperature at which vinyl would flow. The bond is achieved without the use of a cement as vinyl, after laminating, has a natural affinity for glass.

3.1.2 Electrically Heated Windscreens

These windscreens are used on pressurised aircraft to prevent the formation of ice and mist on the panels and to improve the impact resistance of the windscreen panel at low temperatures (see Appendix 2 of Chapter D4–2 of British Civil Airworthiness Requirements or ACJ 25.775(d)). The physical properties of vinyl vary considerably with changes in temperature. Considering a range of ambient temperatures normally encountered under flight operating conditions, the vinyl would be brittle in the lower part of the range and plastic in the upper part. Since the desired impact resistance characteristics of a windscreen depend to a large degree on the plasticity of the vinyl interlayer, it follows that impact resistance is dependent on interlayer temperature.

- a) The panels are of special laminated manufacture containing a resistance type heating element in the form of a film deposited on the inner surface of the outer glass layer. The heating element is supplied with power from the aircraft electrical system via terminals on the panel frame and by busbars 'fired' onto a glass layer at the top and bottom edges of the element. The temperature of the panel is controlled by a temperature-sensing element laminated into the panel and connected to an automatic control unit.
- b) The windscreens in certain of the larger types of aircraft consist of up to seven transparent layers made up of glass, vinyl, acrylic plastic and polyester material. In a typical assembly, three thin vinyl interlayers are employed and they sandwich two layers of thick stretched acrylic plastic. Together the acrylic layers provide most of the windshield structural integrity. The outer layer of the windscreen is a thin, chemically toughened and abrasive-resistant glass layer and its inner face is covered with the heating element which is supplied with power from busbars at the top and bottom of the windscreen. Two sensing elements for automatic temperature control and an overheat sensing element are laminated into the panel. Only one of the control elements is used; the other serves as a spare. The inner layer of the windscreen assembly is made of an abrasion-resistant polyester material.
- c) There are two types of heating elements in general use; namely, tin oxide and gold film, the latter complying with specifications DTD 5576A. These panels are briefly described in the following paragraphs.
 - i) **Tin Oxide Film Panels.** In this type of panel, the heating element is produced by spraying with a flame gun a coating (0.000002 inch thick) of tin oxide at 1000°C on the inner surface of the outer glass layer which is then bonded to the vinyl interlayer.
 - ii) **Gold Film Panels.** In these panels a combined film of gold and metal oxide is used as the heating element. The film is electrically-deposited on the surface of the glass in a vacuum chamber.

3.2 Windscreen Attachment Methods

There are several methods of attaching windscreen assemblies dependent on the type employed. The method frequently adopted for simple type windscreens is the one generally referred to as 'Friction Mounting'; it is illustrated in Figure 1. The periphery of the panel is clamped between metal glazing strips and the fuselage frame by a series of bolts. To avoid damaging the glass and to ensure that the joint will be watertight, a suitable lining, usually in the form of a special rubber strip or moulding, is fitted or bonded to the structure.

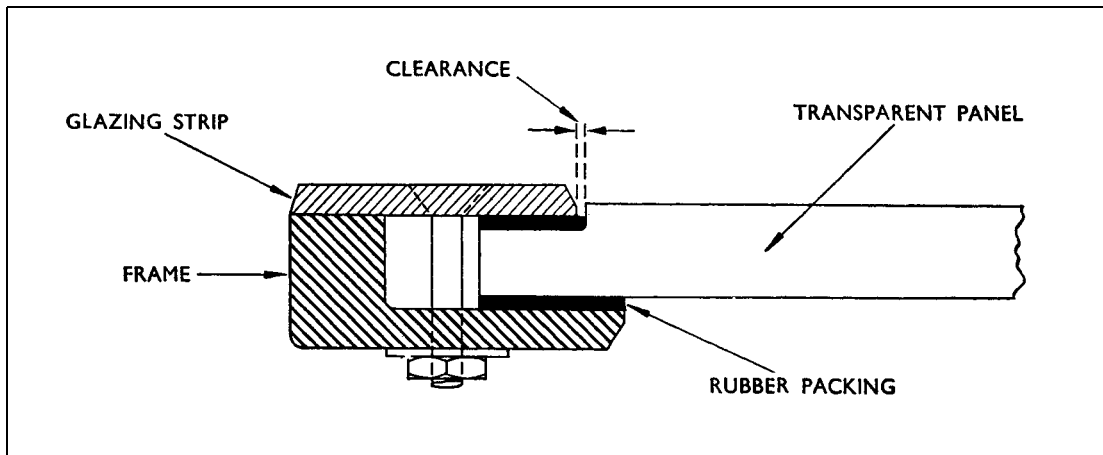

Figure 1 Friction Mounting

3.2.1 The impact strength of a laminated panel is based on the ability of the interlayer to stretch and deform and thus absorb the shock load, assuming that the impact is great enough to shatter the glass layers. Under such conditions it is essential that the vinyl interlayer be held securely around the edges of the panel. It is for this reason therefore, that panels designed to resist high impact loads and in particular electrically heated panels, are secured to the windshield frames by bolts passing through the edges of the panels rather than relying on the clamping action shown in Figure 1.

a) The vinyl interlayer of this type of windscreen is generally thicker than that used in ordinary laminated windscreens and it is extended beyond the periphery of the glass layers. In windscreens employing layers of acrylic plastic this applies to these layers also. A further refinement in the design is an aluminium alloy reinforcing strip, which is in the form of a frame and is embedded in the vinyl. This strip, together with aluminium alloy inserts in each of the bolt holes, assists in preventing the vinyl from deforming at the edges under pressurisation loads and also when tightening bolts during installation. A typical assembly is shown in Figure 2.

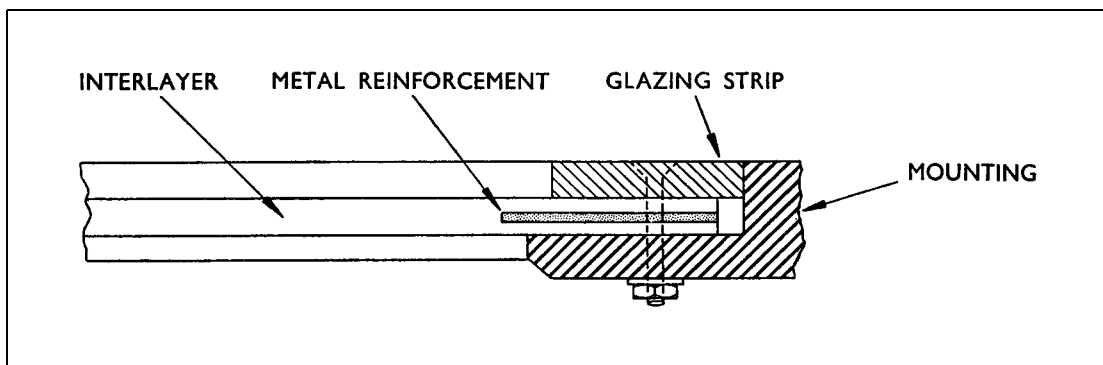

Figure 2 Extended Interlayer Method

4 Installation

The installation of windscreen panels must be in accordance with the procedure specified in the relevant aircraft Maintenance Manual. The information given in the following paragraphs is of a general nature and is intended as a guide.

- 4.1 Before installation, panels should be carefully checked for any sign of damage such as scratches and chips (see paragraph 5.1.2 and 5.1.3). The frames must be clean and seals, where fitted, must be undamaged. Frame mounting faces should be inspected for flatness and freedom from distortion.

NOTE: Cleaning agents must be of the type specified in the relevant aircraft Maintenance Manual and should not be applied indiscriminately to windscreens and surrounding structure. Incorrect cleaning agents may attack the interlayer and cause delamination.

- 4.2 Where specified, clearances between panels and fuselage structure must be checked to ensure that they are within limits. In some instances, particularly for simple type windscreens, the edges of panels are rebated (see Figure 1) to accommodate the glazing strips and specified clearances between strips and raised portions of panels must be maintained.

- 4.3 The condition of pressure and weather seals should be examined before installation of a panel and, where necessary, replaced or repaired in the manner specified for the particular type of aircraft.

- 4.4 In installations requiring a fluid plastic compound for sealing purposes, the compound must be applied in a uniform layer and of the correct thickness to form a gasket between windscreen and fuselage frames, the required thickness being obtained by bolting a windscreen to its respective frame. In some cases a bedding-down template is provided for this purpose.

NOTE: The compound must be left to cure for the relevant time period before finally tightening the attachment bolts.

- 4.5 A silicone grease (sometimes referred to as a release agent) of the type specified in the appropriate aircraft Maintenance Manual, should be applied to the mating surfaces of windscreen frames to form a silicone film which is non-adhesive to pressure and weather seals and facilitates subsequent removal of panels.

NOTE: In some types of aircraft, a preformed strip or gasket may also be fitted to serve this purpose.

- 4.6 On electrically heated windscreen panels fitted to certain types of aircraft, a code number is etched in the corner of the glass near the busbar terminals to indicate the heating element resistance. As it is possible for the number to be covered when the panel is installed, details should be noted before installation to ensure correct heating circuit connections.

- 4.7 In aircraft in which a standby magnetic compass is located on a structural support between two windscreen panels, care must be taken to ensure that the panel attachment bolts in the vicinity of the compass position are of non-magnetic material. After installation, a check compass swing must be carried out to prove the accuracy of the standby compass, with current to the windscreens switched both 'on' and 'off'.

- 4.8 Attachment bolts and nuts should be coated with a compound to provide a seal at each of the bolt holes. Where compounds are specified, details of types and methods of use are contained in the relevant aircraft Maintenance Manual.

- 4.9 During the initial stages of fitting attachment bolts, the panel should always be adequately supported to prevent it resting on the bolts thus preventing the

countersunk heads from seating correctly. Locating keys are provided for this purpose in some types of aircraft and they should be used in the manner specified. When installing windscreens of the extended interlayer type, it is important to ensure that the specified clearance exists between fixing holes and bolts.

- 4.10 Attachment bolts should be tightened evenly and in a staggered sequence ensuring that the panel is not distorted and that bolt torque loadings are as specified.
- 4.11 Cable terminals on electrically heated windscreen panels should be suitably protected against damage. After installation the anti-icing system cables should be connected to their respective terminals, identified in accordance with the relevant wiring diagram and the heating system checked for correct functioning.
- 4.12 After installation of a windscreen panel in a pressurised cabin type aircraft and elapse of the requisite curing time for sealing compounds, a cabin pressurisation and leak rate test should be carried out if prescribed in the relevant aircraft Maintenance Manual.

5 Inspection and Maintenance

The information given in the following paragraph is of a general nature and should be read in conjunction with the Maintenance Manuals and approved Maintenance Schedules for the aircraft concerned.

5.1 Damage

Panels should be inspected for defects and any signs of damage such as delamination, chipping and cracking of glass layers. The following brief descriptive details are intended as a guide to this type of damage and other defects which may occur.

5.1.1 Delamination

This is a defect which can occur in laminated windscreens characterised by the separation of a glass layer from the vinyl interlayer. Delamination should not be confused with deliberate stress-relieving edge separation of panels which is sometimes employed. In such cases a parting medium is used, introducing a separation penetrating the edges of the panel assembly to a distance of 6 mm to 25 mm (0.25 inch to 1 inch) and giving a yellowish or brownish appearance at the edges.

- a) Defective delamination has characteristics that tend to divide it into the following main types and resulting from different types of stress at the glass/vinyl interface.
 - i) **Clear (or cloudy)**. Of the two types, delamination is apt to be clear. However cloudy delamination will result if moisture penetrates the delaminated area. In doubtful cases delamination can be confirmed by carrying out a reflection test by means of a flaw detector using a light beam. The beam is directed onto the surface of the windscreen and produces two sharply defined lines on a ground-glass screen representing the top and bottom surfaces of the windscreen. Any delamination present will produce an additional line and its proximity to either of the other lines is helpful in deciding which of the layers has separated.
 - ii) **Rough-edge**. This is characterised by its irregular, sharp or jagged boundary. It may develop long finger-like projections if, during the course of delamination the parting between vinyl and glass is not uniform.

- iii) **Smooth-edge.** Smooth-edge delamination advances with a smooth boundary. It does not have rough or jagged areas within it, nor indications of internal cracks or chips.
- b) A small amount of delamination is permitted on most aircraft but details of the permissible extent and any limits concerned with aircraft flight operations, e.g. flights under pressurised conditions, should be obtained from the relevant aircraft Maintenance Manual and Flight Manual.

5.1.2 Scratches

Scratches are defects in the surface of a panel and every effort must be made to avoid them. They are normally more prevalent on the outer surface where windshield wipers are indirectly the primary cause. Any dust or grit trapped by a wiper blade can immediately become an extremely effective cutting device as soon as the wiper is set in motion. Wiper blades must therefore be maintained in a clean condition and should only be operated when the windscreens are wet.

- a) On the basis of severity, scratches may be classified as hairline, light and heavy.
 - i) **Hairline Scratches.** A hairline scratch can be seen but is difficult to feel with a fingernail. It can be caused by wiping the glass with a dry cloth. To avoid hairline scratches, the glass should be cleaned with a mild detergent and water, using a soft brush or clean, soft cotton cloth, followed by drying with a clean, soft cotton cloth.
 - ii) **Light Scratches.** A light scratch is less than 0.254 mm (0.010 inch) deep and can be felt with a fingernail. This type of scratch ordinarily has few edge chips.
 - iii) **Heavy Scratches.** A heavy scratch is 0.254 mm (0.010 inch) or more in depth and can be readily felt with a fingernail. This type of scratch is apt to show extensive edge chipping.
- b) If the integrity of a panel is not suspected and provided visibility is not seriously affected, scratches are permissible within limits detailed in the relevant aircraft Maintenance Manual.
- c) Scratches can be removed by polishing, but due to an uneconomic time factor, possible optical distortion and problems of assessing optical standards acceptable in the ultimate operational situations, it is recommended that a panel assembly be returned to the manufacturer and replaced by a serviceable assembly.

5.1.3 Chipping

Chips are flakes or layers of glass broken from the surface which can occur if the exterior surfaces of a panel are struck by a sharp object. The inner surfaces of a lamination of the panel may also chip in unheated areas, as a result of high internal stresses. There are two types of chips: conchoidal and V-shaped. Conchoidal chips are usually circular or curved in shape with many fine striations that follow the outline of the outer edge. V-shaped chips are sharp and narrow, the 'V' appearing to propagate toward the interior of the glass. Visibility through chipped areas of a windscreen panel is usually poor.

- a) Chips occurring at the inner surfaces of glass panels are critical because the existing condition may result in cracking or shattering of a pane, or in the case of an electrically heated windscreen, destruction of the resistance heating film. These chips are usually associated with rough-edge delamination (see paragraph 5.1.1).

5.1.4 **Cracks**

These are serious defects which, depending on the type of glass and the formation and propagation of the cracks, may result in considerable strength reduction of the windscreen and effects on visibility varying from slightly impaired to complete obscurity. In annealed glass the damage may take the form of single cracks, or cracks forming an irregular criss-cross pattern. The more usual result of damage to strengthened glass is the formation of cracks spreading radially from the point of damage and in these cases, vision is impaired but not completely obscured. Cracks in a toughened glass form a pattern defined as shattering, a defect resulting in considerable reduction in strength and loss of vision. A windscreen having such a defect should be removed and replaced by a serviceable assembly.

- a) The extent to which cracks are permitted, limitations on aircraft operation and the action to be taken in order to rectify the defects, may vary between aircraft types. Details are given in the relevant aircraft Maintenance Manual and Flight Manual and reference must therefore always be made to these documents.

5.1.5 **Vinyl Rupture**

Vinyl rupture consists of a failure across the section of vinyl at the inner edge of the metal insert (Figure 2) and necessitates changing the panel.

5.1.6 **Vinyl 'Bubbling'**

Small bubbles occurring within the vinyl interlayer of electrically heated windscreens are not a delamination nor are they structurally dangerous. They are usually due to overheating conditions, being formed by a glass liberated by the vinyl. They need not be a cause for windscreen replacement unless vision is seriously impaired. Their presence, however, may indicate a defective window heat control system which should be rendered inoperative pending rectification.

5.1.7 **Discolouration**

Electrically heated windscreens are transparent to direct light but they normally have a distinctive colour when viewed by reflected light. This apparent discolouration is due to the resistance heating film and it may vary slightly between windscreens. Only black or brown discolouration, when viewed normal to the surface, should be regarded as a possible defect necessitating removal of the windscreen and replacement by a serviceable one. The cause of such discolouration may be a burnout of the heating film or a carbon deposit between a busbar and the heating film due to overheating.

5.2 **Sealants**

Weather sealants provided around the periphery of windscreens must be inspected for evidence of erosion, lack of adhesion, separation or holes. The obvious purpose of maintaining an effective weather sealant is to protect the windscreens against moisture entry and the delamination or electrical problems associated with moisture penetration. When new sealant is required, the damaged material should be removed, the area cleaned and new material applied in the manner prescribed in the relevant aircraft Maintenance Manual.

NOTE: Damaged material should always be removed with a plastic tool that will fit, without binding, in the gap between windscreen and frame. The use of a metal tool is inadvisable, as this could damage the glass or vinyl interlayer.

5.3 **Cleaning of Windscreens**

Windscreens should be washed regularly with warm water and mild detergent, using a clean, soft cloth or cotton wool pad; after washing the panels should be rinsed and dried with a clean, soft cotton cloth. Scratching of the glass must be avoided.

- 5.3.1 Some aircraft manufacturers recommend the use of a proprietary detergent which is also suitable for the surrounding aircraft structure and therefore to some extent simplifies cleaning operations; it is important that only the detergent specified is used and that the prescribed proportion of detergent to water is observed.
- 5.3.2 Grit, dirt, etc., should be removed at regular intervals from recesses, for example, where the panel joins the frame, to prevent it being picked up by the cleaning cloths and causing scratching. The accumulation of cleaning and polishing materials in recesses must be avoided.

6 **Storage**

Extreme care is necessary during transportation, storage and handling of windscreens to prevent damage. It is recommended that panels should be packed with both faces covered with adhesive polythene; they should then be wrapped in acid-free paper and cellulose wadding and put into reinforced cartons, these being covered with waxed paper and secured with adhesive tape.

- 6.1 The panel should be stored in their cartons on suitable racks, away from sunlight or strong artificial light, at a controlled temperature of between 10°C to 21°C (50°F to 70°F) in well ventilated conditions.
- 6.2 It is important to ensure that during handling or storage the thicker glass ply of a laminated panel is kept uppermost to prevent delamination (see paragraph 5.1) and that the polythene film is not removed until the panel is fitted to the aircraft.

INTENTIONALLY LEFT BLANK

Chapter 61 Propellers/Propulsors

Leaflet 61-10 Propellers Approved for use on Civil Aircraft Manufactured in the United Kingdom

- 1 Propellers listed in the attached Appendix are approved for use on civil aircraft manufactured in the United Kingdom with Certificates of Airworthiness issued by the Civil Aviation Authority. In addition, for those aircraft types which have a current Civil Aviation Authority Type Certificate Data Sheet (TCDS), that TCDS should be consulted for details of approved propellers. For aircraft designated as EASA aircraft in CAP 747, the EASA TCDS, if issued, should be consulted.
NOTE: Propellers listed in this Leaflet also include those which have been approved for aircraft certificated in the Special Category only, and it would therefore be wrong to assume that the aircraft listed against a propeller type will automatically qualify for certification in other Categories with that propeller fitted.
- 2 For convenience, propellers are listed under types of engines, but each propeller is approved only for the specific engine-airframe combination shown.
- 3 Propellers manufactured after the date of this Leaflet to the same drawing numbers as those given in the attached list may, in addition, bear certain issue numbers. These issue numbers are used mainly to indicate minor modifications which do not affect safety, but in some cases the intention is to indicate changes in pitch or diameter. In addition, propellers manufactured by other appropriately approved organisations are accepted, provided it is shown that manufacture is in accordance with the relevant drawing requirements.
 - 3.1 Where an issue number has been used to indicate a minor modification and the pitch and diameter remain the same as against the drawing number shown in this list, it may be assumed that the propeller is approved.
 - 3.2 Where an issue number has been used to indicate a change in pitch or diameter and either of these differ from the figures given in the attached list, the propeller is not approved unless it actually appears in this list.
- 4 Before fitting a variable-pitch propeller it is essential to ensure that the basic pitch-range setting conforms with the latest setting approved for the particular engine-airframe combination.
- 5 The pitch quoted is that measured at the radius defined by the manufacturer. Usually this is at 70% or 71% of radius, although in some cases it is at 75%.
- 6 On 28 September 2003, responsibility for approval of new engine/propeller combinations for non-Annex II aircraft passed to EASA. The EASA website www.easa.eu.int should be consulted for information concerning any approvals issued for these aircraft after this date. If it is desired to use an unapproved propeller, application for approval should be made in accordance with the procedure prescribed in Chapter A4-4 of British Civil Airworthiness Requirements, for Annex II aircraft, or to EASA for non-Annex II aircraft.
- 7 For propellers approved for imported aircraft of foreign origin, reference should be made to the appropriate publications issued by the Airworthiness Authority concerned, or the relevant manufacturer. Information may also be obtained from the Civil Aviation Authority, Safety Regulation Group.

INTENTIONALLY LEFT BLANK

Appendix 1

Drawing No.	Diam. (ft)	Pitch (ft)	Aircraft
ARDEM X			
Z3405	4.75	2.45	Turbulent, Nipper 3
Z3407	4.75	2.7	Turbulent
HR1201	4.75	2.45	Turbulent, Nipper 3
ASTAZOU XIIH and H1			
FH 76-2-07	8.2	VP	Skyvan Mk. 2
CHEETAH 15, 17 and 27			
CR30/242/1	8.25	VP	Avro 19
CR30/242/4	8.25	VP	Avro 19
CHEETAH 19			
61271A/X3	7.50	7.10	Anson
A66365	7.50	7.10	Anson
CIRRUS MAJOR 2			
A66290/XI	7.00	4.58	Cygnnet
LA520	6.67	4.59	Cygnnet
Z974/1	6.23	5.26	M.18
CIRRUS MAJOR 3			
A66290/X1	7.00	4.58	Messenger
A66290/X6	7.00	4.98	M.18
A66670/X1	6.75	4.82	Messenger
A66697/X6	6.75	4.97	Auster J.5.G, Auster J.5.K, Messenger
A66697/X7	6.75	4.50	Auster J.5.G
A66940/X1	6.00	6.66	Aries
B67869/X1	6.96	4.58	Messenger
B67921/X1	6.67	4.50	Auster J.5.G, Messenger
B67941/X1	6.67	4.97	Auster J.5.G, J.5.K
B67971/X1	6.50	4.99	Auster J.5.G
C67975/X1	6.92	4.58	Messenger
C67999/X1	6.83	4.76	Messenger 2A
HR669	6.84	3.53	Messenger
LA520	6.67	4.59	Cygnnet
Z3756	6.30	5.15	Messenger
Z6013	6.67	4.51	Blackburn B2, Messenger
Z6014	6.67	4.70	Messenger

Drawing No.	Diam. (ft)	Pitch (ft)	Aircraft
CIRRUS MINOR I			
A66580/X6	6.00	4.28	Auster 5.J.4, Taylorcraft 'C' and 'D'
B67936/X2	5.92	4.28	Taylorcraft 'D'
C66897/X3	5.88	4.28	Taylorcraft 'D'
H020-178-120L	5.83	3.9	Auster 5.J.4
H020-183-105L	6.00	3.44	Auster 5.J.4
LA505	5.87	3.38	Auster 5.J.4, B.A. Swallow 2, Taylorcraft 'C' and 'D'
LA544	5.88	4.15	Mosscraft M.A.2
LA617	6.65	2.75	Taylorcraft 'D'
N209	5.87	3.38	B.A. Swallow 2
Z5701	5.50	4.78	Taylorcraft 'D'
Z8020	5.87	4.27	B.A. Swallow 2, Taylorcraft 'D'
Z8022	6.00	3.62	Auster 5.J.4, Taylorcraft 'C' and 'D', B.A. Swallow 2

CIRRUS MINOR II & IIA

A66580/X1	6.00	4.61	Auster 5.J.1
A66580/X2	6.00	4.52	Auster 5.J.1
A66619/X1	5.75	5.22	Gemini
A66619/X2	5.75	5.09	Gemini
A66619/X4	5.75	4.93	Gemini
A66619/X6	5.75	4.79	Auster 5.J.1, Gemini
A66859/X2	5.50	5.46	Gemini
A66929	5.75	5.22	Gemini
B66883/X1	5.86	4.52	Auster 5.J.1
B67858/X2	5.75	4.79	Auster 5.J.1
B67859/X1	5.87	4.60	Auster 5.J.1
B67992/X1	5.73	4.74	Auster 5.J.1
B67933/X1	5.73	4.78	Auster 5.J.1
B67936/X1	5.92	4.52	Auster 5.J.1
B67943/X1	5.73	4.74	Auster 5.J.1
B67944/X1	5.75	4.74	Auster 5.J.1
B67987/X1	5.67	4.74	Auster 5.J.1
B67990/X1	5.92	4.52	Auster 5.J.1
C66631/X1	5.75	4.66	Auster 5.J.1
C66897/X1	5.88	4.52	Auster 5.J.1
C66897/X2	5.88	4.84	Auster 5.J.1
C66897/X3	5.88	4.28	Auster 5.J.1
C66914/X1	5.67	5.22	Gemini
C66934/X1	5.83	4.52	Auster 5.J.1
C67891/X1	5.94	4.52	Auster 5.J.1
FP400/2A-1 and -2	5.42	5.07	Gemini, Auster 5.J.1
HR702	5.75	3.97	Auster 5.J.1
HR702/2	5.75	4.11	Auster 5.J.1
HR724	5.42	5.07	Gemini
HR1241	6.00	4.04	Auster 5.J.1

Drawing No.	Diam. (ft)	Pitch (ft)	Aircraft
CIRRUS MINOR II & IIA (continued)			
H020-178-120L	5.83	3.9	Auster 5.J.1
H020-183-105L	6.00	3.44	Auster 5.J.1
Z5435	5.50	4.65	Gemini
Z5641	6.00	4.04	Auster 5.J.1
Z5642	6.00	4.04	Auster 5.J.1
Z5646	6.00	4.04	Auster 5.J.1
Z5647	6.00	4.04	Auster 5.J.1
Z5701	5.50	4.78	Auster 5.J.1, Gemini
Z5702	5.50	4.78	Gemini
Z5704	5.50	5.06	Gemini
Z5705	5.25	5.02	Gemini
Z5801	5.64	3.83	Auster 5.J.1
CONTINENTAL C75			
1188/3	6.33	3.48	Auster 5.J.2
1188/4	6.33	3.29	Auster 5.J.2
1188/5	6.00	3.29	Auster 5.J.2
Z5750	5.75	3.97	Auster 5.J.2
Z5751	6.00	3.22	Auster 5.J.2
CONTINENTAL C125			
FP422	5.67	5.65	Gemini
FP422/2	5.67	5.33	Gemini
HR728	5.67	5.33	Gemini
CONTINENTAL O-200			
F-H2/LC14-183 110 7R	6.00	3.6	Linnet
HR1211	5.75	3.2	Auster J.4, Condor
HR1212	5.75	3.2	Auster J.4, Condor
Z5792	5.75	3.97	Linnet
Z5793	5.75	3.2	Auster J.4, Condor
R. R. CONTINENTAL O-200A			
1A101/DCM-69-52	5.75	4.33	Linnet
1A105/SCM/7053	6.84	4.42	Beagle B121
D11/28/7C	5.76	4.13	Auster J.4
Z5723	5.1	4.78	Linnet
Z5794	5.75	3.7	Linnet
HR1211	5.75	3.2	Auster J.4, Condor
HR1212	5.75	3.2	Auster J.4, Condor
R. R. CONTINENTAL O-240A			
HR1631	5.83	4.16	Condor
HR1633	5.83	4.00	Condor
1C172/EM	6.00	4.08	Condor

Drawing No.	Diam. (ft)	Pitch (ft)	Aircraft
CONTINENTAL GIO-470			
2AF36C68/100 RFM-10	7.50	VP	Beagle B.206Y
R. R. CONTINENTAL GIO-470			
2AF36C68/100 RFM-10 to -12	7.50	VP	Beagle B.206 Series 1
CONTINENTAL GTSIO-520-C			
3AF34C86/90LF	7.5	VP	Beagle B206 Series 2
HC-A3VF/2/V8833	7.37	VP	Beagle B206 Series 2
DART 514			
CR201/4-30-4/20	12.00	VP	HS 748 Series 1
DART 531 and 531U			
CR212/4-30-4/22	12.00	VP	HS 748 Series 2
DART 532, 532-2S and 532-2L			
CR212/4-30-4/22	12.00	VP	HS 748 Series 2A
DART 532-2L, 532-2S, 533-2, 534-2, 535-2 and 536-2T			
CR212/4-30-4/22	12.00	VP	HS 748 Series 2 and 2A
DART 533-2			
CR212/4-30-4/22	12.00	VP	HS 748 Series 1
DART 534-2, 535-2 and 536-2			
CR212/4-30-4/22	12.00	VP	HS 748 Series 2B
CR251/4-30-4/49	12.00	VP	HS 748 Series 2B
GIPSY 1			
DH5180/5	6.33	5.08	DH.60G
GIPSY 2			
DH5180/14	6.33	5.00	DH.60G
GIPSY 3			
67104A/X2	7.00	5.10	DH.80A
67104A/X12	7.00	5.18	DH.80A
DH5212/D	6.17	5.42	DH.80A
DH5218/C	6.50	5.16	DH.80A
E860/1	6.87	4.26	Blackburn B2
LA520	6.67	4.59	DH.80A
LA543	7.00	4.00	Blackburn B2
GIPSY MAJOR (AUSTER 3)			
DH5220/P25	6.33	4.58	Auster 3
LA596	6.50	5.00	Auster 5.c
61187A/X11	6.75	5.18	Hawk Trainer

Drawing No.	Diam. (ft)	Pitch (ft)	Aircraft
GIPSY MAJOR 1			
5232/A/1	6.50	5.10	DH.83
61187A/X1	6.75	5.50	Hawk Trainer, Whitney Straight
61187A/X9	6.75	5.24	Falcon, Monarch
61326A/X1	6.17	5.92	DH.85, Whitney Straight
61326A/X2	6.17	5.56	Whitney Straight
61326A/X4	6.17	6.58	DH.85
61326A/X8	6.17	6.01	DH.85, Whitney Straight, DH.87B
61326A/X9	6.17	5.72	Monarch, Whitney Straight
61326A/X10	6.17	5.85	Whitney Straight
61414A/X2	6.58	5.65	DH.85
67104A/X2	7.00	5.10	DH.80A, DH.83, DH.85
67104A/X3	7.00	4.95	DH.87B
67104A/X4	7.00	4.77	DH.82A, DH.83, DH.85, DH.87B
67104A/X6	7.00	5.33	DH.80A, DH.83, DH.85
67104A/X7	7.00	4.71	DH.87B
67104A/X10	7.00	4.60	DH.82A, DH.83, DH.85, DH.87B
67104A/X11	7.00	5.52	DH.85
67104A/X12	7.00	5.18	DH.85, DH.87B, DH.82A
67104A/X13	7.00	5.40	DH.85
67104A/X14	7.00	4.52	DH.82A, DH.83, DH.85
67104A/X15	7.00	5.01	DH.85
67575A/X1	7.00	4.71	DH.82A
84723A/X1	7.00	4.84	DH.82A, DH.87B
94103A/X17	6.75	4.80	Falcon
A66016/X4	7.00	4.58	DH.82A
A66696/X1	6.75	4.83	Auster 5.J.1.B; J.1.N; 5.J.5; J.5.B; J.5.F; J.5.Q; 5D; 3
A66696/X3	6.75	4.67	Auster 5.J.1.B; 5.J.5; J.1.N; J.5.B
A66753/X1	6.75	5.01	Auster J.1.N, DH.82A
A66772/X2	6.50	5.00	Auster J.5.B
A66860/X1	6.50	5.66	Auster 5.C
A66911/X3	6.00	5.77	Hawk Trainer
A66938/X2	7.50	3.52	DH.82A, Jackaroo
A104940/X2	7.42	3.52	DH.82A, Jackaroo
A104940/X3	7.42	3.70	DH.82A
A104941/X2	7.34	3.56	Jackaroo
A104942/X2	7.25	3.59	Jackaroo
A104943/X2	7.17	3.75	Jackaroo
A104943/X3	7.17	3.62	DH.82A, Jackaroo
A104944/X2	7.09	3.62	Jackaroo
A104945/X2	7.00	3.60	Jackaroo
B66131/X1	5.92	5.92	Monarch
B66143/X1	6.74	5.49	DH.85, DH.87B
B66143/X2	6.74	4.69	DH.82A
B66980/X1	6.58	5.24	Falcon, Monarch
B67926/X1	6.42	4.80	Auster 5.J.5; 5.J.1.B; J.5.B

Drawing No.	Diam. (ft)	Pitch (ft)	Aircraft
GIPSY MAJOR 1 (continued)			
B67927/X2	6.92	4.60	DH.87B
B67940/X1	6.57	3.83	Auster 5D
B67995A/XI	6.33	5.12	Auster J.5.F
B104952/X1	6.92	4.07	Jackaroo
B104952/X2	6.92	3.95	Jackaroo
B104956/X1	6.30	5.12	Auster 5.J.1.B; J.1.N; 5.J.5; J.5.B; J.5.F; J.5.Q; 5D; 3
B104977/X1	6.37	5.12	Auster J.5.F
BA211/2	6.18	5.41	Whitney Straight
C66969/X1	5.92	4.50	DH.82A, DH.87B
C67887/X1	6.63	4.83	Auster 5.J.1.B; J.1.N; 5.J.5; J.5.B; J.5.F; J.5.Q; 5D; 3
C67927/X1	6.92	5.18	DH.87B
DH5180/14/21	6.33	5.00	Auster 5D
DH5200/M	6.33	4.50	Auster J.1.N; J.1.B; J.5
DH5208/C/2	6.33	4.92	DH.80A
DH5212/A	6.17	5.25	DH.90A
DH5212/C	6.17	5.17	DH.84
DH5212/D	6.17	5.42	Whitney Straight, DH.80A, DH.82A, DH.84, DH.90A
DH5212/G	6.17	5.14	DH.84
DH5218/B	6.50	5.10	DH.80A, DH.82A, DH.84
DH5218/BX/10	6.50	5.10	DH.83
DH5220/B	6.33	5.08	DH.82A
DH5220/G	6.33	4.58	DH.82A, DH.83
DH5220/H	6.33	4.92	Auster J.1.N., DH.82A, DH.83, DH.84
DH5220/L	6.33	4.75	DH.82A, Auster 5D, 5.J.5., 5.J.1.B
DH5220/M	6.33	4.50	DH.82A, Auster 5D, 5.J.1.B, 5.J.5, J.1.N
DH5220/P	6.33	4.58	Auster 3; 5.D; 5.J.1.B; 5.J.5; J.1.N; J.5B; DH.60G; DH.82A; DH.87B
DH5220/B (Poncelet)	6.33	5.08	DH82A
DH5220/G (Poncelet)	6.33	4.58	DH82A
DH5220/H (Poncelet)	6.33	4.92	DH82A
DH5220/L (Poncelet)	6.33	4.75	DH82A
DH5220/M (Poncelet)	6.33	4.50	DH82A
DH5220/P (Poncelet)	6.33	4.58	DH82A
DH5228A	6.00	5.25	DH.84
DH5228/B	6.00	5.12	DH.84
DH5230/H	6.33	4.92	Auster J.1.N
DH5232/A	6.50	5.10	DH.80A, DH.82A, DH.83, DH.84, DH.85
DH5232/B	6.50	5.30	DH.82A, DH.83, DH.84, DH.85
DH5234/A	6.75	5.08	DH.80A, DH.82A, DH.85
DH5234/B	6.75	4.95	DH.80A, DH.82A, DH.85, DH.87B
DH5234/D	6.75	4.80	DH.80A, DH.85, DH.87, DH.87B, Messenger
DH5234/E	6.75	4.50	DH.85, DH.87A, DH.87B
DH5234/H	6.75	4.30	DH.87B

Drawing No.	Diam. (ft)	Pitch (ft)	Aircraft
GIPSY MAJOR 1 (continued)			
DH5234/J	6.75	4.40	DH.85, DH.87B, DH.82A
DH5250/B	6.33	5.17	DH.80A, DH.90A, Auster J.1.N
HR671	6.84	3.53	DH.82A, Jackaroo
HO21-198B-140L	6.49	4.59	Auster J1N, DH.82A
HO21-198B-140LK	6.49	4.59	DH.82A
HO21-207S-155LK	6.79	5.08	DH.87B
HO21-208B-108L	6.82	3.54	DH.82A
HO21LM-198B-140L	6.49	4.59	DH.82A
HO21LM-207S-155LK	6.79	5.08	DH.82A
LA506/3	6.50	4.35	DH.82A
LA510	6.50	5.36	Monarch, Whitney Straight, DH.85
LA520	6.67	4.59	DH.90A
LA523	6.50	5.16	Auster J.1.N
LA543	7.00	4.00	Blackburn B2
LA550	6.67	5.05	Hawk Trainer
LA550/1	6.67	5.05	DH.85
LA594/2	6.50	4.35	DH.82A
LA596	6.50	5.00	DH.82A, DH.84, DH.85, Hawk Trainer, Messenger, Whitney Straight
LA596/3	6.50	5.36	DH.87B
LA604	6.50	4.58	DH.82A, DH.84, DH.87B
LA604/AM	6.50	4.51	Auster J.1.N
LA623/2	6.84	3.53	Mercury
OP60/B	6.16	5.42	Hawk Trainer, Whitney Straight, Falcon
Z970	6.23	5.72	Hawk Trainer
Z970-2	6.38	6.23	Falcon
Z971	6.23	5.26	DH.82A, Monarch, Whitney Straight
Z973	6.23	5.50	DH.80A, DH.82A, DH.90A, Falcon, Hawk Trainer, Monarch, Whitney Straight, Auster J.1.N
Z978	5.85	5.50	DH.82A, Auster J.1.N
Z1510	6.36	5.20	DH.84
Z2010	6.50	5.65	Falcon
Z3101	6.42	5.22	DH.90A
Z3104	6.50	5.42	DH.90A
Z5890	6.50	4.49	Auster 3; 5.D; 5.J.1.B; 5.J.5
Z8010	6.84	3.53	DH.82A, Jackaroo
Z8014	6.84	3.53	Auster J.5.B, Auster J.1.N, Auster 3G
ZD5220/1	6.33	4.83	DH.82A
871	6.50	3.05	DH.82A
1993	6.04	4.18	DH.82A
94103A/X13	6.75	4.92	Chipmunk

Drawing No.	Diam. (ft)	Pitch (ft)	Aircraft
GIPSY MAJOR 1C			
61326A/X9	6.17	5.72	Monarch
66875/X4	6.50	5.84	Gemini
67104A/X7	7.00	4.71	DH.87B
A66696/X1	6.75	4.83	Auster J.5.F
A66753/X1	6.75	5.01	Leopard Moth
A66875/X4	6.50	5.84	DH.82A
A66938/X3	7.50	3.70	Jackaroo
A104940/X3	7.42	3.70	Jackaroo
B66143/X2	6.74	4.69	DH.82A
B104951/X2	6.75	5.02	DH.82A
B104952/X1	6.92	4.07	Jackaroo
DH5220/H (Invincible Airscrews Pty.)	6.33	4.92	DH82A
DH5220/M	6.33	4.50	Auster J.1.N
DH5220/P	6.33	4.58	Auster J.1.N, DH.82A, DH.83
DH5220/P (Poncelet)	6.33	4.58	DH82A
DH5234/D	6.75	4.80	DH.85, DH.87B
DH5234/E	6.75	4.50	DH.85
HO21-198B-140L	6.49	4.95	DH.82A
HO21-198B-140LK	6.49	4.59	DH.82A
HO21-207S-155LK	6.79	5.08	DH.87B
LA596	6.50	5.00	Hawk Trainer, DH.87B
LA604	6.50	4.58	DH.82A
Z973	6.23	5.50	Gemini, Hawk Trainer
Z5620/2	6.50	4.33	Messenger
Z8010	6.84	3.53	DH.82A, Jackaroo
GIPSY MAJOR 1D			
67104A/X10	7.0	4.60	DH.87B
A66696/X1	6.75	4.83	Messenger
DH5234/J	6.75	4.40	DH.87B
HR671	6.84	3.53	Messenger
LA596	6.50	5.00	Messenger
LA604	6.50	4.58	Messenger
Z971	6.23	5.26	Messenger
Z973	6.23	5.50	DH.90A
Z5620/2	6.50	4.33	Messenger
Z5623	6.50	4.30	Messenger
Z8010	6.84	3.53	Messenger
GIPSY MAJOR 1F			
1993	6.04	4.18	DH82A
61326A/X8	6.17	6.01	DH87B
67104A/X10	7.00	4.60	DH82A, DH87B
67104A/X12	7.00	5.18	DH82A, DH87B
67104A/X14	7.00	4.52	DH82A
67104A/X3	7.00	4.95	DH87B
67104A/X4	7.00	4.77	DH82A, DH87B

Drawing No.	Diam. (ft)	Pitch (ft)	Aircraft
GIPSY MAJOR 1F (continued)			
67104A/X7	7.00	4.71	DH87B
67575A/X1	7.00	4.71	DH82A
84723A/X1	7.00	4.84	DH82A, DH87B
871	6.50	3.05	DH82A
A104940/X2	7.42	3.52	DH82A
A104940/X3	7.42	3.70	DH82A
A104943/X3	7.17	3.62	DH82A
A66016/X4	7.00	4.58	DH82A
A66753/X1	6.75	5.01	DH82A
A66938/X2	7.50	3.52	DH82A
B66143/X1	6.74	5.49	DH87B
B66143/X2	6.74	4.69	DH82A
B67927/X2	6.92	4.60	DH87B
C66969/X1	5.92	4.50	DH82A, DH87B
C67927/X1	6.92	5.18	DH87B
DH5212/D	6.17	5.42	DH82A
DH5218/B	6.50	5.10	DH82A
DH5220/B	6.33	5.08	DH82A
DH5220/G	6.33	4.58	DH82A
DH5220/H	6.33	4.92	DH82A
DH5220/L	6.33	4.75	DH82A
DH5220/M	6.33	4.50	DH82A
DH5220/P	6.33	4.58	DH82A, DH87B
DH5220/B (Poncelet)	6.33	5.08	DH82A
DH5220/G (Poncelet)	6.33	4.58	DH82A
DH5220/H (Poncelet)	6.33	4.92	DH82A
DH5220/L (Poncelet)	6.33	4.75	DH82A
DH5220/M (Poncelet)	6.33	4.50	DH82A
DH5220/P (Poncelet)	6.33	4.58	DH82A
DH5232/A	6.50	5.10	DH82A
DH5232/B	6.50	5.30	DH82A
DH5234/A	6.75	5.08	DH82A
DH5234/B	6.75	4.95	DH82A, DH87B
DH5234/D	6.75	4.80	DH87B
DH5234/E	6.75	4.50	DH87B
DH5234/H	6.75	4.30	DH87B
DH5234/J	6.75	4.40	DH82A, DH87B
HO21-198B-140L	6.49	4.59	DH82A
HO21-198B-140LK	6.49	4.59	DH82A
HO21-207S-155LK	6.79	5.08	DH87B
HO21-208B-108L	6.82	3.54	DH82A
HO21LM-198B-140L	6.49	4.59	DH82A
HO21LM-207S-155LK	6.79	5.08	DH82A
HR671	6.84	3.53	DH82A
LA506/3	6.50	4.35	DH82A
LA594/2	6.50	4.35	DH82A

Drawing No.	Diam. (ft)	Pitch (ft)	Aircraft
GIPSY MAJOR 1F (continued)			
LA596.	6.50	5.00	DH82A
LA596/3	6.50	5.36	DH87B
LA604.	6.50	4.58	DH82A, DH87B
Z8010.	6.84	3.53	DH82A
Z971	6.23	5.26	DH82A
Z973	6.23	5.50	DH82A
Z978	5.85	5.50	DH82A
ZD5220/1	6.33	4.83	DH82A
GIPSY MAJOR 1H			
A66875/X4	6.50	5.84	DH82A
B66143/X2	6.74	4.69	DH82A
B104951/X2	6.75	5.02	DH82A
DH5220/H (Invincible Airscrews Pty.)	6.33	4.92	DH82A
DH5220/P	6.33	4.58	DH82A
DH5220/P (Poncelet)	6.33	4.58	DH82A
HO21-198B-140L	6.49	4.59	DH82A
HO21-198B-140LK	6.49	4.59	DH82A
LA604.	6.50	4.58	DH82A
Z8010.	6.84	3.53	DH82A
GIPSY MAJOR 1J			
A104940/X2	7.42	3.52	DH.82A
DH5212D	6.17	5.42	Hawk Trainer
HR671	6.84	3.53	DH.82A
LA604	6.50	4.58	DH.82A, Hawk Trainer
Z973	6.23	5.50	Hawk Trainer
Z8010	6.84	3.53	DH.82A
GIPSY MAJOR 10 Mks. 1-1, 1-3, 1-7			
A66578/X1	6.75	4.64	DH.85
A66661/X2	6.75	5.01	Chipmunk
A66661/X3	6.75	4.71	Chipmunk
A66661/X4	6.75	4.75	Auster 6A
A66696/X1	6.75	4.83	Auster J.1.N, DH.82A, Beagle, A61 Series 2
A66696/X1/3	6.33	4.67	Beagle A61 Series 2
A66696/X3	6.75	4.67	Auster J.5.L, Auster J.5.P, Chrislea Super Ace, Auster A61, DH.85, Auster 6A, Beagle A61 Series 2
A66696/X6	6.75	4.19	Auster J.5.P
A66753/X1	6.75	5.01	Chipmunk
A66875/X1	6.50	5.72	Gemini
A66875/X3	6.50	6.02	Gemini
A66875/X4	6.50	5.84	Gemini
A66875/X7	6.50	6.22	Gemini
A66938/X2	7.50	3.52	Auster 6A

Drawing No.	Diam. (ft)	Pitch (ft)	Aircraft
GIPSY MAJOR 10 Mks. 1-1, 1-3, 1-7 (continued)			
A66938/X3	7.50	3.70	Auster 6A
A67960/X1	6.75	4.67	Auster J.5.P, Beagle A61 Series 2
A94103A/X11	6.75	5.34	Chipmunk
B67934/X1	6.62	4.71	Chipmunk
B67935/X1	6.75	5.01	Chipmunk
DH5232/AR/5	6.50	5.10	DH.82A
DH5234-B	6.75	4.95	Beagle A61
HR671	6.84	3.53	Chrislea Super Ace
HR708	6.33	4.33	Chrislea Super Ace
LA596	6.50	5.00	Gemini
Z971	6.23	5.26	Messenger
Z973	6.23	5.50	Gemini, Hawk
Z1510	6.36	5.20	Desford Trainer
Z5623/1	6.50	4.30	Messenger, Chrislea Super Ace
Z5672	6.25	4.44	Messenger, Chrislea Super Ace
Z5780	6.50	4.05	Messenger, Chrislea Super Ace
Z8010	6.84	3.53	Messenger, Chrislea Super Ace
Z8014	6.84	3.53	Auster 6A, Beagle Auster A61, Beagle A61 Series 2

GIPSY MAJOR 10 Mks. 1-1A, 1-3A, 1-7A, Mk. 2, 2-1

A66753/X1	6.75	5.01	Auster J.1.N, Chipmunk, DH.85, Gemini 3C
A66904/X1	6.50	5.24	Chipmunk, Desford/Bobsleigh
A67925/X2	6.75	4.02	Chipmunk
A67925/X3	6.75	4.67	Auster 6A, Beagle A61, Auster J.5.P, J.5.R, J.5.L
A67960/X1	6.75	4.67	Auster J.5.L, J.5.P, J.5.R, Auster 6A, Beagle A.61
A67960/X2	6.75	4.19	Auster J.5.P, Auster J.5.R
A67889	6.75	5.01	Chipmunk
B104972	6.47	5.01	Chipmunk
B104973	6.30	5.36	Chipmunk
B67871/X1	6.58	5.01	Chipmunk
D67972/X1	6.50	5.84	Chipmunk, Gemini
D67972/X2	6.50	5.20	Gemini
D67972/X5	6.50	5.72	Chipmunk, Falcon, Gemini
D67989/X2	6.75	4.67	Auster J.5.L
D67996/X1	6.76	3.88	Chipmunk
D104967/X1	6.75	5.01	Chipmunk
HO21-198B-140L	6.49	4.59	Chipmunk
HO21-198B-140LK	6.49	4.59	DH.82A
HO21-208B-108L	6.82	3.54	Chipmunk
HO21HM-198B-140L	6.49	4.59	Chipmunk
HO21HM-198B-140LK	6.49	4.59	Chipmunk
HR864	6.50	4.58	Messenger, DH.87B
Z976	6.23	5.50	Falcon, Gemini

Drawing No.	Diam. (ft)	Pitch (ft)	Aircraft
GIPSY MINOR			
DH5258/A	5.88	3.96	DH.94
DH5258/E	5.88	4.19	DH.94
DH5258/J	5.88	4.03	DH.94
DH5258/K	5.88	4.00	DH.94
HR1312	5.88	4.03	DH.94
GIPSY QUEEN 3			
61186A/X4	7.00	6.48	DH.89, DH.89A
61186A/X6	7.00	6.33	DH.89, DH.89A
61186A/X9	7.00	5.94	DH.89, DH.89A
61186A/X12	7.00	6.41	DH.89, DH.89A
A66327/X2	6.75	5.90	DH.89, DH.89A
A67967/X2	7.00	6.65	DH.89, DH.89A
A67967/X3	7.00	6.46	DH.89, DH.89A
A67967/X5	7.00	5.45	DH.89, DH.89A
B66936/X1	6.83	5.94	DH.89, DH.89A
B66937/X1	6.83	5.94	DH.89, DH.89A
B67982/X1	6.42	6.25	DH.89, DH.89A
GIPSY QUEEN 30-2			
PD70/212/1/2	7.50	VP	Prentice
GIPSY QUEEN 30-3 and 30 Mk. 2			
PD136/212/1/2	7.00	VP	DH.114
PD170/212/1/2	7.00	VP	DH.114
PD175/212/1/2	7.00	VP	DH.114
PD190/212/1	7.00	VP	DH.114
GIPSY QUEEN 70-3 and 70-4			
PD116/312/1 to /7 inc.	7.50	VP	DH.104
PD143/312/1 to /7 inc.	7.50	VP	DH.104
GIPSY QUEEN 70 Mk. 2			
PD143/312/1 to /7 inc.	7.50	VP	DH.104
GIPSY QUEEN 70 Mk. 3			
PD143/312/1 to /7 inc	7.50	VP	DH.104

Drawing No.	Diam. (ft)	Pitch (ft)	Aircraft
GIPSY SIX 1			
61025A/X2	7.00	6.47	DH.86, DH.89, DH.89A
61052A/X3	7.00	6.29	DH.89, DH.89A
61052A/X5	7.00	6.03	DH.89, DH.89A
61186A/X2	7.00	6.66	DH.86, DH.86B, DH.89, DH.89A
61186A/X3	7.00	6.56	DH.86, DH.86B, DH.89, DH.89A
61186A/X4	7.00	6.48	DH.89A, DH.89
61186A/X5	7.00	6.39	DH.89A, DH.89
61186A/X6	7.00	6.33	DH.86, DH.86B, DH.89, DH.89A
61186A/X7	7.00	6.28	DH.89, DH.89A
61186A/X9	7.00	5.94	DH.89A
61186A/X12	7.00	6.41	DH.89A
61189A/X1	7.00	7.11	Hawk
61189A/X5	7.00	6.96	Hawk
61189A/X7	7.00	6.84	Hawk
61189A/X8	7.00	7.29	Hawk
61375A/X1	7.00	6.76	Gull
61375A/X2	7.00	7.03	Hawk
A66327/X2	6.75	5.90	DH.89A
A67967/X2	7.00	6.65	DH.89
A67967/X5	7.00	5.45	DH.89A
B66128/X1	7.00	6.75	DH.89, DH.89A
B66942/X1	6.67	6.62	Hawk
C66026/X1	6.75	6.81	DH.89, DH.89A
C66093/X1	6.75	6.66	DH.86B, DH.89, DH.89A
DH5238/F	6.75	6.30	DH.86, DH.89, DH.89A
DH5238/G	6.75	6.40	DH.86, DH.89, DH.89A, Heck
DH5238/H	6.75	6.40	DH.89, DH.89A
DH5238/J	6.75	6.20	DH.89, DH.89A
DH5244/A	6.75	6.40	DH.89, DH.89A
DH5244/B	6.75	6.30	DH.89, DH.89A
DH5246/B	6.75	6.20	DH.86, DH.89, DH.89A
Z1800	6.92	6.20	Hawk
Z2192	6.75	6.18	DH.89, DH.89A
Z2682/1	6.72	6.20	DH.86, DH.89, DH.89A
Z2682/7	6.56	6.18	DH.89, DH.89A
Z2687	6.56	6.43	DH.86, DH.86B
Z2688	6.56	6.29	DH.89, DH.89A
Z2689	6.56	6.50	DH.86, DH.86B
GIPSY SIX 2			
PD30/211/1	7.00	VP	Proctor 1, 2, 3, 4, 5
PD154/211/1	6.75	VP	Mew Gull
PD209/211/1	7.00	VP	Mew Gull

Drawing No.	Diam. (ft)	Pitch (ft)	Aircraft
LEONIDES 501, 502, 503 and 504			
CR162/3-20-3/5 or /5P	9.00	VP	President
PD158/313/1	9.00	VP	Prince
PD159/313/1	9.00	VP	Prince
PD184/313/1	9.00	VP	Beaver
PD232/313/1 and /2	9.00	VP	Prince, President
LEONIDES 503/8, 504/8 and 514/8			
PD205/323/1	11.00	VP	Twin Pioneer
LEONIDES 514/5A			
CR143/3-20-3/2	9.00	VP	President 2A
LEONIDES 531/8B			
PD237/323/1	11.00	VP	Twin Pioneer
LYCOMING GO-480-B			
Blade 9333C-3	7.50	VP	E.P.9
Hub HC82x20-1B	7.50	VP	E.P.9
P1033/G4-AD-0691236	7.75	VP	E.P.9
LYCOMING GO-480 G1A6			
Blade 9333C-3	7.50	VP	E.P.9
Hub HC83x20-1B	7.50	VP	E.P.9
P1033/G4-AD-0691236	7.75	VP	E.P.9
LYCOMING O-235-C1			
M76/AM-2-48	6.16	4.00	Auster D4
Z5960	6.50	3.06	Auster D4
LYCOMING O-290-3 and 0-290-C			
1A. 170. LL. 7647	6.33	3.92	Auster 5
FP420	6.25	4.18	Auster 4 and 5
HO-30-190-112	6.23	3.67	Auster 4 and 5
HR1231	6.50	3.48	Auster 4 and 5
Z5594	6.00	3.67	Auster 4 and 5
Z5600	6.50	3.48	Auster 4 and 5
Z5602	6.50	3.19	Auster 4 and 5
LYCOMING O-320-A2B			
M74DMS-0-60	7.16	5.00	B121 Series 2
74DM6S5-0-60	7.16	5.00	B121 Series 2
LYCOMING O-320-B			
1A/175/GM 8052	6.66	4.33	Auster D5

Drawing No.	Diam. (ft)	Pitch (ft)	Aircraft
LYCOMING O-320-B2B			
M74DM56	6.02	4.08	Auster J5V
1A200/FAM-8043	6.66	3.58	Auster D6
1A200/FAM-8046	6.66	3.83	Auster J5V, Auster D5
LYCOMING O-320-D2C			
M74DMS-0-62	7.16	5.16	B121 Series 3
74DM6S5-0-62	7.16	5.16	B121 Series 3
LYCOMING O-360-A1A			
2D36C14/78KM-4	6.17	VP	Auster J.1.U, Auster D6, Beagle A.109
LYCOMING O-360-A2A			
1A200/FA-8240	6.83	3.33	Auster D5
1A200/FA-8243	6.83	3.58	Auster D5, Auster D6, Auster J.1.U
1A200/FA-8250	6.83	4.16	Auster D5, Auster D6, Auster J.1.U
NIAGARA 3			
Z5740	6.50	8.26	Comper Swift
TPE 331-2			
HCB3TN-5C/T10282HB	8.5	VP	Skyvan 3
HCB3TN-5E/T10282HB	8.5	VP	Skyvan 3
HCB4TN-5C/T10282HB-4P	8.25	VP	Skyvan 3A
HCB3TN-5E/T10232HB	8.5	VP	Skyvan 100-81
TYNE 515-101W			
PD244/476/2	16	VP	Belfast SC5
WALTER MIKRON 2			
A66049/1X1	4.75	3.59	Tipsy Trainer
A66167/X4	5.50	3.44	Tipsy B, Tipsy Trainer
A66167/X5	5.50	3.90	Tipsy B
B66592/X1	5.25	3.56	Tipsy Trainer
LA511	5.05	3.92	Tipsy Trainer
LA553/2	5.35	3.22	Tipsy Trainer

INTENTIONALLY LEFT BLANK

Chapter 70 Engines

Leaflet 70-10 Storage Procedures – General Guidance

1 Introduction

Under normal operating conditions the interior parts of an engine are protected against corrosion by the continuous application of lubricating oil and operating temperatures are sufficient to dispel any moisture which may tend to form; after shutdown the residual film of oil gives protection for a short period. When not in regular service, however, parts which have been exposed to the products of combustion and internal parts in contact with acidic oil, are prone to corrosion. If engines are expected to be out of use for an extended period they should be ground run periodically or some form of anti-corrosive treatment applied internally and externally to prevent deterioration.

- 1.1 The type of protection applied to an engine depends on how long it is expected to be out of service, if it is installed in an aircraft and if it can be turned.
- 1.2 This Leaflet gives guidance on the procedures which are generally adopted to prevent corrosion in engines but, if different procedures are specified in the approved Maintenance Manual or other published information for the particular engine, the manufacturer's recommendations should be followed.
- 1.3 The maximum storage times quoted in the Leaflet are generally applicable to storage under cover in temperate climates and vary considerably for different storage conditions. Times may also vary between different engines and reference must be made to the appropriate manufacturer's documentation for details.

2 Installed Piston Engines

If it is possible to run a piston engine which is installed in an aircraft and expected to be out of service for a period of up to one month, sufficient protection will be provided by running the engine every seven days, but if the period of inactivity is subsequently extended, continued periodic ground running would result in excessive wear and the engine should be placed in long term storage. The run should be carried out at low engine speed (1000 to 1200 rev/min), exercising the engine and propeller controls as necessary to ensure complete circulation of oil, until normal working temperatures are obtained. If the engine cannot be run for any reason, the manufacturer may recommend that it should be turned by hand or motored by means of an external power supply, but generally it will be necessary to inhibit the engine as described below.

2.1 Long Term Storage

When a piston engine is likely to be out of service for a period in excess of one month it should be treated internally and externally with a corrosion inhibitor. The treatments described below are normally considered satisfactory for six months but this may be extended to twelve months in ideal storage conditions. At the end of this period the engine should be prepared for service, given a thorough ground run and re-protected or, alternatively, removed from the aircraft and stored as described in paragraph 4.

2.1.1 Internal Protection

a) American Method

- i) Drain the oil sump and tank and refill with storage oil as prescribed by the manufacturer.
- ii) Run the engine at low speed (1000 to 1200 rev/min) until normal operating temperatures are obtained.
- iii) Spray cylinder protective into the induction system until white smoke issues from the exhaust, then switch off the engine but continue spraying until rotation has ceased.
- iv) Drain the oil sump and remove the filters.
- v) Remove the sparking plugs and spray a fixed quantity of cylinder protective into each cylinder while the engine is turned by hand. A further quantity should then be sprayed into the cylinders with the engine stationary.
- vi) Fit dehydrator plugs in each cylinder and replace oil filters.
- vii) Place a quantity of desiccant in the intake and exhaust and blank off all openings.

b) British Method

- i) Drain the oil sump and tank and refill with the storage oil recommended by the manufacturer.
- ii) Run the engine at low speed (1000 to 1200 rev/min) until normal operating temperatures are obtained.
- iii) Drain all oil from the system and remove filters.
- iv) Remove sparking plugs and spray the specified quantity of cylinder protective into each cylinder while the piston is at the bottom of its stroke, at the same time spraying the valve springs and stems with the valves closed and the valve heads and ports with the valves open. Also spray the valve rocker gear.
- v) Turn the engine at least six revolutions by hand, then spray half the previously used quantity of cylinder protective into each cylinder with the engine stationary.
- vi) Replace oil filters and fit dehydrator plugs.
- vii) Blank off all openings into the engine (intake, exhaust, breathers, etc.).
- viii) Replenish oil tank to normal level with storage oil as specified.

c) Special Requirements

- i) Coolant systems should be drained and thoroughly flushed unless an inhibited coolant is used.
- ii) Fuel system components such as fuel pumps, injectors, carburettors or boost control units also require inhibiting. This is done by draining all fuel and oil as appropriate and refilling with storage or mineral oil as recommended by the manufacturer. Blanking caps and plugs should then be fitted to retain the oil.
- iii) Auxiliary gearboxes should also be inhibited. The normal lubricating oil should be drained and the gearbox refilled with storage oil.
- iv) If the propeller is removed the propeller shaft should be sprayed internally and externally with cylinder protective and correct blanks fitted.

2.1.2 External Protection

Exterior surfaces of the engine should be thoroughly cleaned with an approved solvent such as white spirit, by brushing or spraying and dried with compressed air. Any corrosion should be removed, the area re-treated in accordance with the manufacturer's instructions and chipped or damaged paintwork renewed. The following actions should then be taken:

- a) All control rods should be liberally coated with a general purpose grease.
- b) Magneto vents should be covered.
- c) Sparking plug lead ends should be fitted with approved transport blanks, exposed electrical connections masked and rubber components covered with waxed paper or mouldable wrap.
- d) Spray holes in fire extinguisher pipes should, if possible, be blanked off, using polythene sleeving or waxed paper suitably secured.
- e) An approved preservative (normally lanolin or external air drying varnish) should be sprayed over the whole engine, in a thin even film.

2.2 General Precautions

It is most important that an installed stored engine should not be turned, since this would lead to removal of cylinder protective from the cylinder walls and possibly result in the formation of corrosion at those positions. Physical restraint is seldom practicable, particularly when a propeller is fitted, but warning notices should be fixed on the propeller and in the cockpit to prevent inadvertent rotation of the engine.

3 Installed Turbine Engines

Installed turbine engines which are to be out of use for a period of up to seven days require no protection apart from fitting covers or blanks to the intake, exhaust and any other apertures, to prevent the ingress of dust, rain, snow, etc. A turbine engine should not normally be ground run solely for the purpose of preservation, since the number of temperature cycles to which it is subjected is a factor in limiting its life. For storage periods in excess of seven days additional precautions may be necessary to prevent corrosion. Some general guidance is given below, but the manufacturer's published data should be referred to for details.

3.1 Short-term Storage

The following procedure will normally be satisfactory for a storage period of up to one month.

3.1.1 Fuel System

The fuel lines and components mounted on the engine should be protected from the corrosion which may result from water held in suspension in the fuel. The methods used to inhibit the fuel system depend on the condition of the engine and whether it is installed in an aircraft or not and are fully described in the appropriate Maintenance Manual. On completion of inhibiting, the fuel cocks must be turned off.

3.1.2 Lubrication Systems

Some manufacturers recommend that all lubrication systems (engine oil, gearbox oil, starter oil, etc.) of an installed engine should be drained and any filters removed and cleaned, while others recommend that the systems should be filled to the normal level with clean system oil or storage oil. The method recommended for a particular engine should be ascertained from the appropriate Maintenance Manual.

3.1.3 External Treatment

Exterior surfaces should be cleaned as necessary to detect corrosion, then dried with compressed air. Any corrosion should be removed, affected areas re-treated and any damaged paintwork made good in accordance with the manufacturer's instructions. Desiccant or vapour phase inhibitor should be inserted in the intake and exhaust and all apertures should be fitted with approved covers or blanks.

3.2 Long-term Storage

For the protection of turbine engines which may be in storage for up to six months, the short-term preservation should be applied and, in addition, the following actions taken:

- a) Grease all control rods and fittings.
- b) Blank-off all vents and apertures on the engine, wrap greaseproof paper round all rubber parts which may be affected by the preservative and spray a thin coat of external protective over the whole engine forward of the exhaust unit.

3.2.1 At the end of each successive six months storage period an installed engine should be re- preserved for a further period of storage. Alternatively, the engine may be removed from the aircraft and preserved in a moisture vapour proof envelope.

4 Uninstalled Engines (Piston and Turbine)

Engines which have been removed from aircraft for storage, or uninstalled engines which are being returned for repair or overhaul, should be protected internally and sealed in moisture vapour proof (MVP) envelopes. This is the most satisfactory method of preventing corrosion and is essential when engines are to be transported overseas.

- 4.1 A piston engine should be drained of all oil, the cylinders inhibited as described in paragraphs 2.1.1 b), iv) to viii), drives and inside of crankcase sprayed with cylinder protective and all openings sealed.
- 4.2 A turbine engine should be drained of all oil, fuel system inhibited, oil system treated as recommended by the manufacturer and blanks fitted to all openings.
- 4.3 Particular care should be taken to ensure that no fluids are leaking from the engine and that all sharp projections, such as locking wire ends, are suitably padded to prevent damage to the envelope.
- 4.4 The MVP envelope should be inspected to ensure that it is undamaged and placed in position in the engine stand or around the engine, as appropriate. The engine should then be placed in the stand, care being taken not to damage the envelope at the points where the material is trapped between the engine attachment points and the stand bearers.
- 4.5 Vapour phase inhibitor or desiccant should be installed in the quantities and at the positions specified in the relevant Maintenance Manual and a humidity indicator should be located in an easily visible position in the envelope. The envelope should then be sealed (usually by adhesive) as soon as possible after exposure of the desiccant or vapour phase inhibitor.
- 4.6 The humidity indicator should be inspected after 24 hours to ensure that the humidity is within limits (i.e. the indicator has not turned pink). An unsafe reading would necessitate replacement of the desiccant and an examination of the MVP envelope for damage or deterioration.

- 4.7 After a period of three years storage in an envelope the engine should be inspected for corrosion and re-preserved.

5 Inspection

Engines in storage should be inspected periodically to ensure that no deterioration has taken place.

- 5.1 Engines which are not preserved in a sealed envelope should be inspected at approximately two-weekly intervals. Any corrosion patches should be removed and the protective treatment re-applied, but if external corrosion is extensive a thorough inspection may be necessary.
- 5.2 Envelopes on sealed engines should be inspected at approximately monthly intervals to ensure that humidity within the envelope is satisfactory. If the indicator has turned pink the envelope should be unsealed, the desiccant renewed and the envelope resealed.

6 Equipment and Materials

6.1 Equipment

The spraying equipment should be of a type approved by the engine manufacturer and should be operated in accordance with the instructions issued by the manufacturer of the equipment. For inhibiting cylinders a special nozzle is required and this should be checked immediately before use to ensure that the spray holes are unblocked. Correct operation of the spray gun may be checked by spraying a dummy cylinder and inspecting the resultant distribution of fluid.

6.2 Materials

Only the types of storage and inhibiting oil recommended by the manufacturer should be used for preserving an engine. American manufacturers generally recommend oils and compounds to American specifications and British manufacturers generally recommend storage oil to DEF 2181, wax-thickened cylinder protective to DTD 791, turbine fuel system inhibiting oil to D. Eng. R.D. 2490 and external air drying varnish approved under a DTD 900 specification. Only approved alternatives should be used and any instructions supplied by the manufacturer in respect of thinning or mixing of oils should be carefully followed.

6.3 Blanks

Approved blanks or seals should be used whenever possible. These are normally supplied with a new or reconditioned engine and should be retained for future use. Pipe connections are usually sealed by means of a screw-type plug or cap such as AGS 3802 to 3807 and plain holes are sealed with plugs such as AGS 2108; these items are usually coloured for visual identification. Large openings such as air intakes are usually fitted with a specially designed blanking plate secured by the normal attachment nuts and the contact areas should be smeared with grease before fitting, to prevent the entry of moisture. Adhesive tape may be used to secure waxed paper where no other protection is provided, but should never be used as a means of blanking off by itself, since it may promote corrosion and clog small holes or threads.

7 Removal from Storage

For an engine which was not installed in an aircraft during storage the installation procedure described in the appropriate Maintenance Manual should be carried out, followed by a thorough ground run and check of associated systems. For an engine which was installed in an aircraft during storage the following actions should be taken:

- a) Remove all masking, blanks and desiccant.
- b) Clean the engine as necessary, e.g. remove excess external protective and surplus grease from controls.
- c) Ensure fire extinguisher spray pipe holes are clear.
- d) Replace any components which were removed for individual storage, de-inhibiting as necessary.
- e) Drain out all storage oil, clean oil filters and refill with normal operating oil.
- f) Piston engines; remove sparking plug blanks and turn engine slowly to drain excess oil from the cylinders, then fit plugs and connect leads. Turbine engines; prime the fuel system in accordance with the manufacturer's requirements.
- g) Prime the engine lubricating oil system.
- h) Start the engine and carry out a check of the engine and associated systems.

8 Records

Appropriate entries must be made in the engine log book giving particulars of inhibiting procedures or periodic ground running. Such entries must be signed and dated by an appropriately licensed engineer or Approved Inspector.

Leaflet 70-20 The Process for Acceptance of Used Engines, Engine Modules, Auxiliary Power Units (APUs) and Propellers for Use on NON-EASA Aircraft Requiring a UK Certificate of Airworthiness

1 Introduction

- 1.1 For the purposes of this Leaflet, engines, engine modules, APUs, and propellers are hereafter referred to as Powerplants.
- 1.2 Article 19 of the Air Navigation Order 2009 states that a Certificate of Airworthiness shall cease to be in force if the aircraft is overhauled, repaired or modified otherwise than in a manner and with material of a type approved by the CAA.
- 1.3 Similarly, for non Commercial Air Transport, Article 16(10) (a) requires that a Certificate of Release to Service (CRS) be issued when an aircraft has been overhauled, repaired, modified or maintained in a manner and with material of a type approved by the CAA.
- 1.4 For aircraft which are subject to regulation by EASA under Regulation (EC) 216/2008, Part M Subpart E, M.A.501 and associated AMC/GM material detail how components, including Powerplants, from non-EASA approved sources are to be assessed. Those requirements must be followed for acceptance of such Powerplants for these aircraft and this Leaflet is not applicable.
- 1.5 For Powerplants to be used on aircraft that are not subject to regulation by EASA and are obtained from sources not under the direct airworthiness control of the CAA, this Leaflet defines a procedure which owners/operators must follow in order to meet the requirements of Article 19 or Articles 28, 29, 30 and 31 of the Air Navigation Order 2009 (as amended). The procedure described below is only applicable to Powerplants for “non-EASA” aircraft as defined in CAP 747 Mandatory Requirements for Airworthiness.
- 1.6 Instructions are also included regarding both pool and lease/loan/power-by-the-hour arrangements and the alignment of maintenance programmes to be used on “non-EASA” aircraft.

2 General Requirements

It must be established by the owner’s/operator’s approved maintenance organisation or an appropriately type rated Licensed Aircraft Engineer, as appropriate, that:

- a) the Powerplant is of a type approved by the CAA;
- b) civil identification plates are fitted;
- c) log books or their equivalent, as appropriate, are issued;
- d) original or certified true copies of any relevant documents (e.g. confirming modification standard, test results, etc.) arising from construction or previous Hot Section Inspection (H.S.I.)/Refurbishment/Overhaul/Performance Restoration are provided with the CRS;

- e) the Powerplant is in compliance with all applicable Airworthiness Directives of the State of Design and the CAA;

NOTE: In the case of a Pool Powerplant only the Airworthiness Directives of the State of Design are required as a minimum (see paragraph 8).

- f) any period of storage has been in accordance with the manufacturer's recommendations and that the Powerplant has not become unserviceable due to operational abuse, damage or the removal of components;
- g) the hours and cycles accrued of any life limited parts are clearly defined;
- h) all modifications and repairs embodied in the Powerplant have been approved by the Type Certificating Authority of the Powerplant or the CAA.

3 Alignment of Maintenance Programmes

Powerplant types which in the UK operator's maintenance programme are subject to fixed H.S.I./Refurbishment/Overhaul/Performance Restoration intervals must have the time remaining to these intervals agreed by the CAA when the previous operator's maintenance programme does not specify the same shop visit requirements or intervals.

4 Powerplants with an EASA, JAA, FAA or Transport Canada Authorised Release Document

- 4.1 Powerplants which meet the requirements of Paragraph 2 of this Leaflet and have not been operated since the last H.S.I./Refurbishment/Overhaul/Performance Restoration are acceptable for use if received with an Authorised Release Document as defined in a), b), c) or d):

- a) an EASA form 1;
- b) a JAA Form 1 issued by a JAR-145 Maintenance Organisation listed in the JAA publication 'JAR-145 Listed Organisations';
- c) an FAA Form 8130-3 from an EASA approved FAR-145 Repair Station listed in EASA Foreign Part-145 organisations located in the United States;
- d) a Transport Canada Form 24-0078 from an EASA approved Transport Canada Approved AM573 Maintenance Organisation listed in EASA Foreign Part-145 organisations located in Canada.

- 4.2 If the Powerplant satisfies all of the requirements of paragraphs 2 and 4.1 of this Leaflet, then the following statement, signed by the person issuing the CRS, must be entered into the appropriate log book:

'Part..... S/N..... has been accepted under procedures complying with CAAIP Leaflet 70-20, paragraphs 2 and 4.'

5 Powerplants Operated Under the Airworthiness Control of the EASA, JAA, FAA or Transport Canada since Last H.S.I./Refurbishment/Overhaul/Performance Restoration

- 5.1 Powerplants which meet the requirements of paragraph 2 and the Authorised Release Document requirements of paragraph 4 of this Leaflet, but which have been operated since last H.S.I./Refurbishment/Overhaul/Performance Restoration, will be acceptable for use provided that:

- a) a serviceability statement is obtained from the previous operator declaring any restrictions in hours or cycles relating to inspection, lubrication, replacement or overhaul as necessary to maintain the airworthiness of the Powerplant;
 - b) all defects have been rectified, or recorded;
 - c) the Powerplant has been maintained to an EASA, JAA, FAA or Transport Canada approved maintenance programme.
- 5.2 If the Powerplant satisfies all of the requirements in paragraphs 2 and 5.1 of this Leaflet, then the following statement, signed by the person issuing the CRS, must be entered into the appropriate log book:
- ‘Part..... S/N..... has been accepted under procedures complying with CAAIP Leaflet 70-20, paragraphs 2 and 5.’

6 Powerplants from Other Sources or those Requiring Further Substantiation

- 6.1 This paragraph applies when any of the following circumstances exist:
- a) it is not possible to satisfactorily confirm the origin, traceability or serviceability of the Powerplant;
 - b) the Powerplant is obtained without an EASA, JAA, FAA or Transport Canada Authorised Release Document (as described in paragraph 4 of this Leaflet);
 - c) the Powerplant has not been under the airworthiness control of EASA, JAA, FAA or Transport Canada operator since the last H.S.I./Refurbishment/Overhaul/Performance Restoration;
 - d) the Powerplant does not meet all of the requirements of Section 2.

NOTE: Owners and operators are advised to review the requirements of paragraphs 6.2 and 6.4 of this Leaflet prior to entering into a commercial agreement to purchase a Powerplant.

- 6.2 The owner’s or operator’s maintenance organisation or an appropriately type rated maintenance Licensed Aircraft Engineer, as appropriate, must demonstrate to the satisfaction of the CAA the Powerplant’s acceptability, taking into account the following:
- a) the details of any unapproved modifications and repairs which have been embodied in the Powerplant;
 - b) confirmation that military Powerplants which are similar to a civil equivalent have been modified to comply with civil requirements in conjunction with the manufacturer in each particular case, unless agreed otherwise with the CAA;
 - c) confirmation that the last H.S.I./Refurbishment/Overhaul/Performance Restoration was undertaken to a specification, and by an organisation or person, acceptable to the CAA;
 - d) a statement certifying serviceability (i.e. an Authorised Release Document or equivalent), issued by either the last H.S.I./Refurbishment/Overhaul/Performance Restoration organisation or the previous operator’s maintenance organisation, as appropriate. This organisation must be appropriately authorised by its national airworthiness authority to make such a statement. Alternatively, a statement certifying serviceability issued by the appropriate national airworthiness authority may be acceptable.

- 6.3 If the CAA accepts the Powerplant, the following statement, signed by a CAA Surveyor, must be entered into the appropriate log book:

‘Part..... S/N..... has been accepted by the CAA in accordance with CAAIP Leaflet 70-20, paragraphs 2 and 6.2.’

- 6.4 If the serviceability cannot be adequately established then the Powerplant must be dismantled and inspected.

A suitably approved maintenance organisation or an appropriately type rated Licensed Aircraft Maintenance Engineer must dismantle and inspect the Powerplant. The manufacturer’s recommendations must be used as the basis of the workscope for this activity, which must be sufficient to determine if either of the declarations below can be made. Rectification action must be taken where necessary.

If it cannot be established that the records are accurate and complete, all life limited parts must be scrapped. In addition, the applicant must make reference to the CAA for a decision on whether any other parts should be scrapped in the absence of satisfactory records.

- 6.5 If serviceability is established one of the following statements, signed by the maintenance organisation or the appropriately type rated Licensed Aircraft Maintenance Engineer, as applicable, must be entered into the appropriate log book, either:

‘Part..... S/N..... has been examined in accordance with CAAIP Leaflet 70-20, paragraph 6.4, and no evidence of operational abuse, inadequate maintenance or unsuitable storage has been revealed.’

or

‘Part..... S/N..... has been examined in accordance with CAAIP Leaflet 70-20, paragraph 6.4, and appropriate action has been taken to restore serviceability.’

7 Lease/Loan/Power-by-the-Hour Powerplants

- 7.1 When a Powerplant is obtained on a long-term lease, loan or power-by-the-hour arrangement from a supplier who is either (a) the original manufacturer, or (b) an EASA, JAA, FAA or Transport Canada approved maintenance organisation or repair station defined in paragraph 4 of this Leaflet, then the operator must confirm that:

- a) the Powerplant complies with the requirements of paragraph 2;
- b) the supplier has issued a serviceability statement declaring any restrictions in hours or cycles relating to inspection, lubrication, replacement or overhaul as necessary to maintain the airworthiness of the Powerplant;
- c) the Powerplant has been maintained to either the manufacturer’s maintenance programme, or an EASA, JAA, FAA or Transport Canada approved maintenance programme;
- d) all defects have been rectified or recorded.

- 7.2 The following statement, signed by the person issuing the CRS for the Powerplant, must be entered into the appropriate log book:

‘Part..... S/N..... has been accepted under procedures complying with CAAIP Leaflet 70-20, paragraph 7.’

8 Pool Powerplant

- 8.1 A 'Pool' Powerplant, interchanged between certain operators on a temporary basis (limited to a maximum of 200 hours), is permitted provided:
- a) the conditions relating to airworthiness which apply to the pooling agreement are laid down in advance by the operator, agreed by CAA and lodged permanently in the operator's Maintenance Management Exposition. These conditions require consideration of not only the history of the Powerplant but also the acceptability of the source of the H.S.I./Refurbishment/Repair/Overhaul/Performance Restoration where this is other than by the pool partner.
 - b) the Powerplant is in compliance with all applicable Airworthiness Directives of the State of Design.
 - c) the UK operator obtains from the previous operator a signed statement certifying the Powerplant is airworthy when released on loan, declaring any restrictions in cycles or hours, etc., relating to inspection, lubrication, replacement, or overhaul as necessary to maintain the airworthiness of the Powerplant during the period of loan.
- 8.2 The following statement, signed by the person issuing the CRS for the Powerplant, must be entered into the appropriate log book:
- 'Part..... S/N..... has been accepted under procedures complying with CAAIP Leaflet 70-20, paragraph 8.'

INTENTIONALLY LEFT BLANK

Leaflet 70-30 Acceptance of Ex-UK Government Gipsy Major 8 Engines and Fixed Pitch Fairey Reed Metal Propellers

PURPOSE: This Leaflet provides information on the acceptance of ex-UK Government Gipsy Major 8 engines and Fairey Reed metal propellers for installation on UK registered DH Chipmunk aircraft.

REFERENCES: Rolls-Royce Technical News Sheet TNS GE No. 27 dated 24 October 1974.
CAP 562 Leaflet 61-10
CAP 562 Leaflet 70-20
CAP 747 Generic Requirement (GR) No. 24.

The following information is additional to that given in the above references:

- 1) In order for military engines/propellers to be used in aircraft with a UK Certificate of Airworthiness, acceptance by the CAA is normally required in accordance with CAP 562 Leaflet 70-20. However, this process can be waived for the subject engines/propellers provided the following information is supplied prior to acceptance of an engine or propeller:
 - a) Statement of serviceability from the UK military body from which the engine/propeller was obtained.
 - b) Statement of the engine/propeller build standard from the UK military body or from a CAA approved overhaul organisation, in order to verify that all modifications embodied are CAA approved and that all CAA mandatory modifications have been embodied.
 - c) Statement from the UK military body or from a CAA approved overhaul organisation that all engine/propeller repairs are CAA approved.
 - d) Engine log book. It must be verified that all mandatory inspections have been complied with.
- 2) Rolls-Royce TNS GE No. 27 states that the civilian TBO for the Gipsy Major 8 Mk 2 is 1500 hours. This TBO can be exceeded subject to meeting the requirements of CAP 747 GR No. 24. It should be noted however, that paragraph 3.1.1 c) of this GR states:

'The engine must have been installed and operated in a UK-registered aircraft, or in an aircraft whilst previously registered in another EASA Member State for a period of 200 hours immediately prior to completion of the engine manufacture's recommended overhaul period.'

For the subject engines, the requirement of this paragraph can be waived. This allows engines with a TSO up to 2250 hours (this being the MOD overhaul period limitation) to be accepted by the CAA subject to all other requirements of CAP 747 GR No. 24 (including any applicable calendar life limitations) and Section 1 of this Leaflet being satisfied.

- 1 All Gipsy Major 8 modifications up to and including 4037 have CAA approval. For engines incorporating modifications later than modification 4037, application shall be made to the CAA preferably through the Type Certificate holder for approval or confirmation of civil approval of the modification(s). This may involve the applicant being charged for the investigation.**

2 Propellers approved for use on the civil Chipmunk aircraft are stated in CAP 562 Leaflet 61-10.

NOTE: This Leaflet is applicable to UK Government engines, whether obtained directly from the UK Government or from another source.

Leaflet 70-40 Acceptance of Ex-UK Government Lycoming IO 360-A1B6 Engines and Variable Pitch Propellers

PURPOSE: This Leaflet provides information on the acceptance of ex-UK Government Lycoming engines and Hartzell propellers for installation on UK registered Bulldog aircraft.

REFERENCES: Textron Lycoming Service Instruction No 1009AU
CAP 562 Leaflet 70-20
CAP 747 Generic Requirement (GR) No. 24

The following information is additional to that given in the above references:

1 Acceptance onto UK Register

In order for military engines/propellers to be used in aircraft with a UK Certificate of Airworthiness, acceptance by the CAA is normally required in accordance with CAP 562 Leaflet 11-48. However, this process can be waived for the subject engines/propellers provided the following information is established by the owner's/operator's Part 145 maintenance organisation or an appropriately type rated CAA Licensed Aircraft Engineer, prior to acceptance of an engine or propeller:

- a) Serviceability, based on an appropriate statement from the UK military body from which the engine / propeller was obtained.
- b) Engine/propeller build standard based on an appropriate statement from the UK military body or from a CAA approved overhaul organisation, in order to verify that all CAA mandatory modifications and inspections have been accomplished.
- c) All engine/propeller repairs are CAA approved based on an appropriate statement from the UK military body or from a CAA approved overhaul organisation.
- d) Engine and propeller log books issued.
- e) Civil identification plates are fitted.

2 Engine TBO Recommendations

Textron Lycoming Service Instruction No 1009AU states that the recommended TBO for the IO 360-A1B6 engine is 2000 hours. Paragraph 10 states that 'Some engines in the field have been altered to incorporate an inverted oil system in order to perform aerobatic manoeuvres. Whenever this modification is done to an engine, the TBO of the engine must be determined in the same manner listed for AEIO engines of the same model series'.

It could be considered therefore that the manufacturer's recommended TBO for the engine is reduced to 1400 hours. However, the aerobatic capability of the Bulldog aircraft is limited by the airframe, and is not increased by the fitment of the inverted oil system. It has therefore been decided that a TBO of 1800 hours should be established, which is consistent with the TBO applicable in military service.

This TBO may be subject to extension under CAP 747 GR No. 24. However, it should be noted that paragraph 3.1.1 c) of the GR states:

'The engine must have been installed and operated in a UK-registered aircraft, or in an aircraft whilst previously registered in another EASA Member State for a period of 200 hours immediately prior to completion of the engine manufacture's recommended overhaul period.'

Since the subject engines have clearly been operated and maintained in the United Kingdom the above requirement can be waived. This allows engines with a TSO up to 1800 hours (this being the military TBO limitation) to be accepted for TBO extension subject to all other requirements of CAP 747 GR No. 24 and Section 1 of this Leaflet being satisfied.

3 Propeller TBO Recommendations

For the propeller, the TBOs should be as per the manufacturer's instruction for propellers of this type when fitted to aerobatic aircraft.

4 Timing of TBO

The next TBO for both engine and propeller should be timed from the last overhaul in military service.

NOTE: This Leaflet is applicable to ex-UK Government engines whether obtained directly from the UK Government or from another source. If the engines have been operated since being obtained from the UK Government, and are to be registered for use in Public Transport Category, then the Leaflet does not apply.

Leaflet 70-50 Piston Engine Overhaul – Dynamometer Testing of Overhauled Engines

1 Introduction

- 1.1 After an aero-engine has received a complete overhaul, pass-off tests may be made with the engine fitted with a test fan or mounted on a dynamometer test bench. This Leaflet gives guidance on testing low-power, air-cooled engines when coupled to dynamometers and on the acceptance conditions when overhauled engines are tested by this method.
- 1.2 The Leaflet does not aim to provide a complete guide to approved organisations engaged in aero-engine overhaul. The particular purpose of this Leaflet is to give students and individual engineers an outline of engine test procedure and to draw attention to a number of points of special importance. Before actual tests are attempted an approved Engine Test Schedule must be available. All overhaul work on such engines must be in accordance with the manufacturer's instructions given in the Overhaul Manual and all tests must be made as prescribed in the approved Engine Test Schedule for the particular type.
- 1.3 Guidance on the testing of overhauled engines by means of test fans and the prescribed acceptance conditions when engines are tested by this method, are given in Leaflet 70-60. Performance correction of test data is covered in Leaflet 70-70.

2 General

- 2.1 The method of testing an engine on a dynamometer test bench enables the engine output to be determined in terms of brake power, whereas this is not practicable when the engine is tested with a fan or flight propeller unless the engine incorporates a torquemeter of known accuracy or the torque reaction on the engine mounting can be measured with exactitude.
- 2.2 Since the engines with which this series of Leaflets is concerned are not usually fitted with torquemeters, their performance after overhaul may be assessed by testing them when fitted with calibrated test fans, in which case, as explained in Leaflet 70-60, the corrected rpm obtained under specified conditions is taken as a measure of the engine performance. However, before an engine can be so tested, the test fan itself must be calibrated in the test cell to be used, on an engine, the performance of which has been determined on a dynamometer test bench.

3 Test Plant

A dynamometer is a heavy machine which must be rigidly mounted. This fact and the necessity of making adequate arrangements for water, electricity, fuel and oil supplies, for exhaust gas disposal, for drains, for silencing and for ventilation means that dynamometer testing is usually performed in a permanent test house. It is beyond the scope of this Leaflet to describe such a test house in detail but attention is drawn, in the following paragraphs, to a number of important features:

- 3.1 A dynamometer test bench consists of a mounting for the engine, a coupling shaft for interconnecting the engine to the dynamometer, a fan and the necessary ducting for cooling the engine, a starting system for the engine, the necessary controls and

- instruments for operating the engine and measuring its performance and systems for supplying the engine with fuel and oil and the dynamometer with water. In the case of supercharged engines a depression box should be provided for the air intake so that altitude conditions can be simulated when specified in the Engine Test Schedule.
- 3.2 When an engine is mounted on the test bench, care should be taken that the engine propeller shaft is in exact alignment with the shaft of the dynamometer, but the coupling should not be completed until the zero setting of the torque measuring equipment has been checked. Guidance on the procedure for this check is given in paragraph 4.
 - 3.3 The coupling shaft between the engine and dynamometer must be specially designed. It must be light in weight, properly supported and in perfect dynamic balance. Cardan shafts incorporating two universal joints are normally used; they should be inspected before the start of the test to ensure that they have not been disturbed in any way that could upset their alignment or dynamic balance.
 - 3.4 All test and measuring equipment must be of an approved type. All instruments should be calibrated periodically and thereafter should be checked for accuracy at regular intervals by an organisation approved for the purpose. Measuring equipment should also be checked at regular intervals. Engine speed indicators should be checked with a stop watch against a revolution counter and, during tests, cross-checks should be made by measuring of the engine speed using a 'Hasler' type instrument.
 - 3.5 Before commencing the test, the oil filter elements in the feed lines should be either cleaned or renewed. Oil tanks should be drained and flushed at intervals of approximately 100 hours' running time.
 - 3.6 Before checking oil consumption or oil circulation, the oil temperature must be stabilised at the check temperature specified in the appropriate test schedule. To obtain this condition, the test plant must be provided with suitable means of heating or cooling the oil as required. If the heating is accomplished with an electric immersion heater there is danger of damaging the chemical structure of the oil, since the surface temperature of this type of heater can rise to high values when the flow rate of the oil is low. It is therefore recommended that the oil is heated via a heat exchanger, using steam at a controlled pressure if a source is available but otherwise using a circulating water supply as a means of conveying heat from an immersion heater to the oil.
 - 3.7 Engine oil consumption can be checked by either of the following methods:
 - a) Readings of oil volume should be taken from a graduated sight glass fitted externally to the oil tank. The readings should be recorded each 15 minutes during the prescribed stages of the test schedule and the difference between the initial and final readings can be used to calculate oil consumption in litre/h (pint/h).
 - b) On an engine which has a 'wet sump' lubrication system, the oil should be drained out and weighed at the end of the running-in period, replaced in the engine, then drained out and weighed again after the Endurance Test. The difference between these weights will enable the oil consumption to be calculated.
 - 3.8 The fuel pressure gauge connection should be made at the inlet to the carburettor or fuel injector. A fuel flowmeter calibrated in litre/h or kg/h (pints/h or lb/h) must be tapped into the fuel supply line and readings must be taken as called for in the test schedule appropriate to the engine.
 - 3.9 To avoid unscheduled stoppages during the test, all pipe connections should be properly made and all pipes should be adequately supported. The test bench controls

should be checked for alignment and range of movement and the engine baffles and cowlings should be firmly secured.

- 3.10 Measurements of the exhaust back pressure should be made as close to the engine as possible but, where more than one manifold is provided because of the cylinder configuration, the pressure at each silencer connection should be checked and the mean reading obtained. If it is inconvenient to measure the pressure from each connection throughout the test, the pressure tapping with the value closest to the mean reading may be used.

4 Types of Dynamometer

There are three principal types of dynamometer commonly used for the testing of aero-engines, the hydraulic type, the electrical (direct-current) type and the eddy-current type. With all types, the engine under test is directly coupled to the rotor shaft of the dynamometer, which can be loaded to obtain the desired engine speed. The dynamometer absorbs the power output of the engine and, in doing so, experiences a torque reaction on its own casing. It is by measurement of this torque reaction that the brake power of the engine is determined; it can be calculated from a simple formula which takes into account the torque reaction and the rpm of the dynamometer rotor.

$$\text{Brake Power} = \frac{\text{torque (Nm)} \times 2\pi \times \text{rpm}}{60\,000} \text{ kW or } \frac{\text{torque (lb ft)} \times 2\pi \times \text{rpm}}{33\,000} \text{ BHP}$$

4.1 Hydraulic Dynamometers

A part sectioned view of a typical hydraulic dynamometer is illustrated in Figure 1. The shaft of this machine carries a rotor which has a series of semi-elliptical cups separated by vanes; the rotor runs between two sets of similar cups formed in the casing. Water at constant pressure is fed into the casing. Rotation of the shaft circulates this water by centrifugal force around the orbits formed by the opposing pairs of moving and static cups, the water thus absorbing the power fed into the machine by the engine under test. The shaft is supported in the casing by ball bearings and the casing itself is mounted on trunnion bearings which allow it to rotate in response to torque reaction. The reaction on the casing is balanced and the rotation of it constrained, by a system of weights and levers and a spring balance which, when correctly preset, indicates the load due to torque.

The loading on the engine can be reduced by adjusting a pair of shrouds, known as sluice gates, so that they progressively mask the rotor cups from the cups in the casing and can be increased by the reverse process. The type illustrated is a non-reversible dynamometer but reversible types are also made. The latter have two rotors and two sets of casing vanes, one to work clockwise and the other anti-clockwise.

NOTE: The following instructions are applicable when the testing is done with a Non-reversible Froude Type D.P.Y. dynamometer. Since this dynamometer is the type most widely used for testing small aero engines, these instructions have been included as an example. Should any other types of hydraulic dynamometer be employed, instructions for its use must be obtained from the manufacturer.

- 4.1.1 Before coupling an engine to the dynamometer, the static balance of the weighing apparatus should be checked. This is done in the following way:
- a) Adjust the inlet and outlet water valves so that there is a steady flow of water through the dynamometer.

- b) A dashpot prevents oscillations of the torque lever arm from being transmitted to the spring balance. When the spring balance is being checked the dashpot should be freed by setting its adjusting nut to zero.
- c) Remove all loose balance weights from the end of the lever arm, leaving the fixed static weight in place.
- d) If the lever arm is not in a position slightly above the bottom stop on the bedplate, the adjustment on the interconnection to the spring balance should be reset. The adjustment should be checked by raising the lever arm which should cause the pointer of the spring balance to make one revolution before the lever arm touches the top stop in the spring balance column.
- e) By moving and locking the small sliding weight on the lever arm, the pointer of the spring balance should then be reset to zero. The dynamometer is then ready for the test and the engine should be coupled to it, care being taken to ensure exact alignment of the engine and dynamometer shafts.
- f) A final check should be made by alternately lifting and depressing the lever arm by hand, when the pointer should settle down to zero and it should be possible by depressing the lever arm to move the pointer a few degrees to the minus side of zero, without causing stiffness or binding. The adjusting nut of the dashpot should then be screwed down so that the by-pass will be partially closed, although final adjustments must be made when the engine is running.

NOTE: If the spring balance does not register sufficient load to balance the output of the engine under test, the load may be increased by adding extra balance weights. These are marked with figures representing the correct weight which must be added to the load registered on the spring balance and the sum of weights and registered load will then represent the factor W in the formula given in paragraph 4.1.3 for calculating Brake Power.

4.1.2 Before starting an engine coupled to a non-reversible dynamometer, the water inlet valve should be fully opened but the outlet valve should only be opened slightly. Engines under test should be run-in under their own power with an initial light load. For starting purposes it is advisable to close the sluice gates to minimise the load on the engine; afterwards, as the engine is opened up in incremental stages, the load should be progressively increased by opening the sluice gates, to maintain the specified operating conditions. As the engine power is increased the water outlet valves should be adjusted so that they pass sufficient water to keep the water temperature at a reasonable level; about 60°C is satisfactory.

4.1.3 It has been stated that the power of the engine can be found if the torque and the rpm of the rotor are known. The torque is calculated by multiplying the length of the lever arm by the effective weight lifted. Since the lever length, the value of π and the power conversion factor are all constant, the simplified formula given below can be used. The formula introduces a constant K known as the dynamometer constant, which has a value determined for each type of dynamometer by its manufacturer. The value of K, which varies with the length of the lever arm, is stamped on the nameplate of each dynamometer. The formula is therefore:

$$\text{Brake Power} = \frac{W \times N}{K}$$

where W = net weight lifted by dynamometer

N = rpm of rotor

K = dynamometer constant

4.2 **Electrical Dynamometers**

The type of electrical dynamometer usually supplied for the testing of small engines consists of a generator designed so that it will also function as an electric motor. Thus when supplied with electrical power it can be used for running-in a newly-assembled engine or when driven by an engine under test it generates electrical energy. The first of these functions is not normally applicable to overhauled aero-engines, which are run-in under their own power, but it does provide a means of measuring the power required to overcome the internal resistance of an engine when this information is required. The armature shaft of a typical electrical dynamometer is carried by bearings in the casing of the machine and the casing is itself carried in co-axial bearings which allow it to swivel in the same direction of rotation as the shaft. When an engine is driving the armature shaft with the dynamometer connected to an electric circuit, the turning moment is resisted by a combination of bearing friction, electro-magnetic reaction and air resistance. These three loads each tend to rotate the casing, to which is attached a lever arm and weighing apparatus similar to that of a hydraulic dynamometer. The magnitude of the total force acting on the casing is indicated on a spring-balance dial, which enables the engine power to be found by the method given in paragraph 4.1.3.

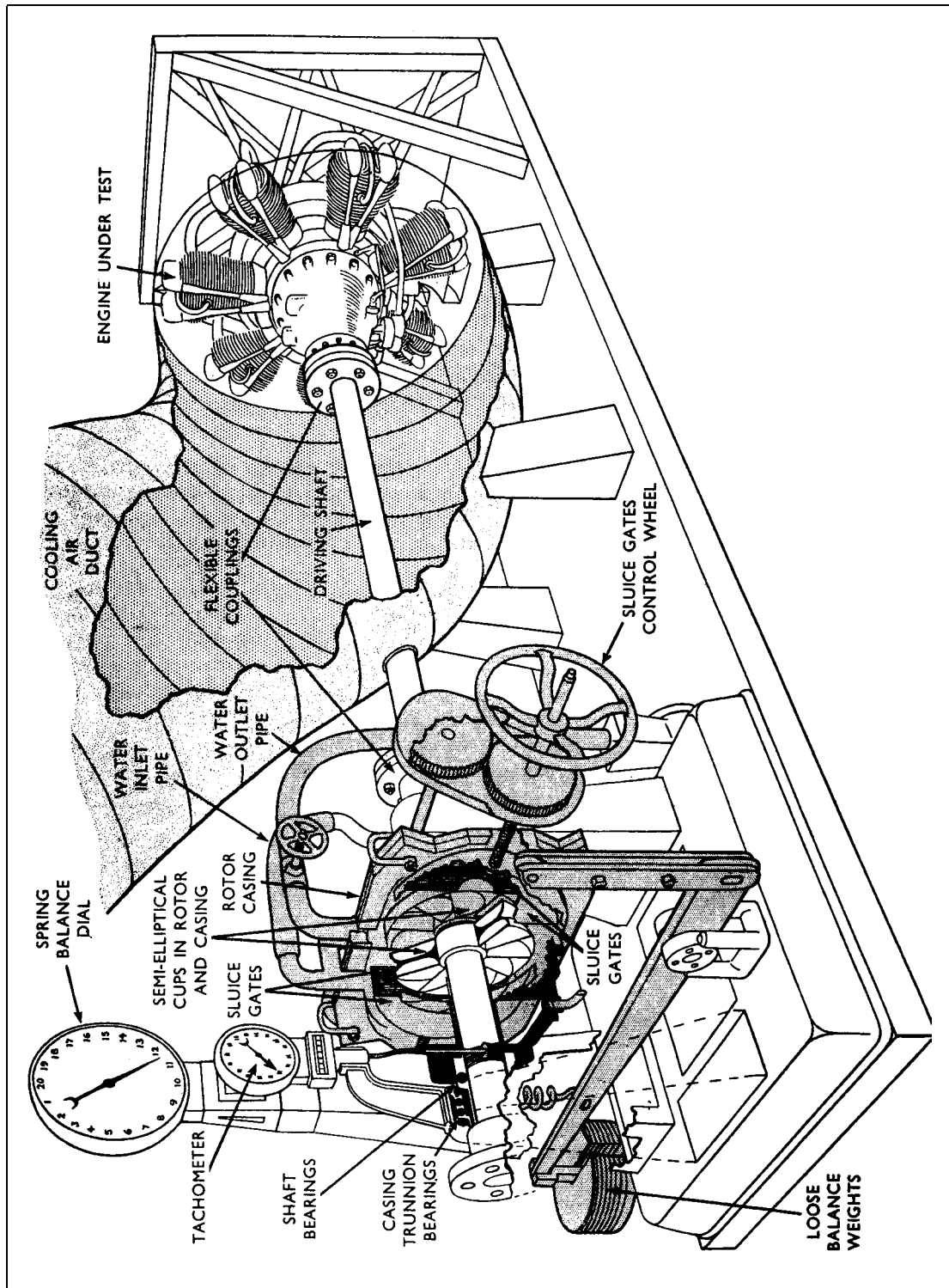

Figure 1 Radial Engine Coupled to Froude Hydraulic Dynamometer

4.3 Eddy-current Dynamometers

The single frame electrical dynamometer described in paragraph 4.2 is not designed to absorb high powers and therefore an eddy-current dynamometer is more often used for testing engines which develop over 150 kW (200 BHP). An eddy-current dynamometer is an electrical machine in which the rotor is manufactured with a number of coarse teeth which act as magnetic poles. The rotor turns inside a stator which incorporates one or more field coils excited by a small amount of direct current,

so that during rotation concentrations of magnetic flux are produced at each pole of the rotor. The flux concentrations induce eddy-currents in the stator and it is these which resist the rotation of the rotor and therefore load the engine under test. The degree of power absorption is controlled by regulating the amount of excitation of the main field coils. The engine power is converted into heat by the braking effect of the machine and cooling water has therefore to be circulated to conduct the heat away. In this type of dynamometer the water outlet temperature should not exceed 60°C but if possible it should be limited to 50°C as this will help to reduce the possibility of internal scale formation. As with the hydraulic and electric types of dynamometer, the engine power is found by measuring the torque reaction exerted on the stator casing. The casing is mounted on trunnion bearings which allow some freedom of oscillation and attached to the casing is a lever arm which operates weighing gear. The engine power is found by the method given in paragraph 4.1.3.

4.4 **Dynamometer Plant for Helicopter Engines**

Engines intended to be installed in helicopters should normally be tested in the attitude in which they will be mounted in the airframe. Thus when the axis of rotation of the crankshaft is to be vertical in service, one solution is to provide a right-angled gearbox to couple the engine to the dynamometer. The dynamometer itself can be of any type capable of absorbing the power output of the engine but the brake power readings obtained from it must be corrected for the power absorbed by the gearbox. (This information is usually obtainable from the manufacturer of the gearbox). Since helicopter engines are not always provided with integral reduction gears, a right-angled gearbox may be designed with a reduction ratio to assist in matching the engine speed to the characteristics of the dynamometer. If required, hydraulic dynamometers can be made to run directly coupled to helicopter engines without the introduction of a gearbox and in addition special dynamometers can be made to suit vertical or any other shaft inclination desired. In some special cases both dynamometer and engine can be arranged on a swivel to give variable adjustment of shaft inclination. The test bench may also be designed so that the engine is provided with an external source of cooling air since, if it drives its own cooling fan, it may be necessary to make allowance for the power absorbed by the fan.

5 **Test Running and Observations**

After the engine has been coupled to the dynamometer and the preparations for starting and running have been completed, the engine should be tested strictly in accordance with the approved Test Schedule appropriate to the type. The observations made during the tests should be recorded on properly prepared test log sheets. During the tests attention should be given to the following points:

- 5.1 The engine should be tuned according to the instructions in the approved Test Schedule. The observed fuel flowmeter readings must be corrected to standard conditions; formulae and/or charts for this purpose are normally provided with the schedules supplied by engine manufacturers. Likewise, the fuel flow acceptance limits (see paragraph 6.1.2) are normally quoted in the same source.
- 5.2 At each stage of test running, a careful watch should be kept for signs of defects and such undesirable behaviour as excessive oiling, vibration, breather discharge or detonation.
- 5.3 Single ignition checks should be made and the power drop measured. As each magneto is switched OFF, the engine load should be reduced, e.g. by opening the sluice gates on a hydraulic dynamometer, so that the rpm is restored to that obtained with both magnetos operating. The differences in power output between operation with single and dual ignition should be recorded on the log sheets.

- 5.4 Usually, the Final Test calls for a power/rpm curve to be drawn at the Maximum Weak-mixture Power manifold pressure. To obtain this curve the engine should be run over the range of rpm specified in the Test Schedule. The resultant curve should be smooth; if it is not so and any of the points plotted diverge to any appreciable extent, the readings should be rechecked.
- 5.5 If, after rechecking, it is necessary to adjust or replace any component or part, the test, or portions of it, will have to be repeated, unless otherwise agreed by the manufacturer.

6 Acceptance Conditions

The acceptance conditions for overhauled engines tested on a dynamometer test bench are defined in the appropriate approved engine Test Schedule. Apart from the general running standard of each engine and its ability to satisfactorily complete the tests detailed in the relevant schedule, the specific standards of performance defined must be achieved to permit pass-off.

Leaflet 70-60 Piston Engine Overhaul – Fan Testing of Overhauled Engines

1 Introduction

- 1.1 After an aero-engine has received a complete overhaul, pass-off tests may be made with the engine either fitted with a test fan or mounted on a dynamometer test bench. This Leaflet gives guidance on testing low-power, air-cooled piston engines by means of test fans and on the acceptance conditions when overhauled engines are tested by this method.
- 1.2 Since the engines with which the series is concerned are more often tested by the fan method than on a dynamometer test bench, this Leaflet gives fairly detailed information on the methods used for choosing test fans to suit particular engines and for calibrating test fans. It also draws attention to a number of other points of special importance. Before tests are attempted, an approved Engine Test Schedule (see paragraph 2) must be available. All overhaul work on engines must be in accordance with the manufacturer's instructions given in the Overhaul Manual and all tests must be made as prescribed in the Engine Test Schedule for the particular type.
- 1.3 Guidance on the testing of overhauled engines on dynamometer test benches and the acceptance conditions prescribed when engines are tested by this method, are given in Leaflet 70-50. Performance correction of test data is covered in Leaflet 70-70.

2 General

Engine manufacturers prepare Test Schedules and instructions which are approved for use when testing particular engine types. These schedules are based on ensuring that the performance defined in the Engine Technical Certificate is met.

- 2.1 Although the Requirements recognise two basic methods of testing piston engines after overhaul, the test fan method, because of its lower cost, is most frequently used for testing the smaller engines. This method entails fitting the engine with an approved type of test fan which is calibrated to absorb the power output of the engine at a specified rpm. Since torque meters are not usually fitted to the small engines with which this Leaflet is concerned, the rpm obtained when running with a calibrated fan is used to indicate the engine power. However, the results obtained can be grossly inaccurate unless exceptional care is exercised in the application of the method.
- 2.2 Since helicopter engines should normally be tested in the attitude in which they will be installed in the helicopter, engines which are intended to be installed with the axis of rotation either vertical or inclined from the horizontal may be tested on a dynamometer test bench specially designed for the purpose (Leaflet 70-50). However, tests on such engines are often run with the engine loaded by a paddle-bladed fan, in which case it is sometimes necessary to change the paddles to suit conditions at the various stages of the test run. Thus paddles of one diameter ('A' plates) may be specified for running at Maximum Continuous Power conditions and paddles of a different diameter ('B' plates) for running at Maximum Take-off Power conditions. Whilst paddle-bladed fans are calibrated in a similar manner to aerofoil-bladed fans, the technique of rendering them 'heavy' or 'light' is of course different.

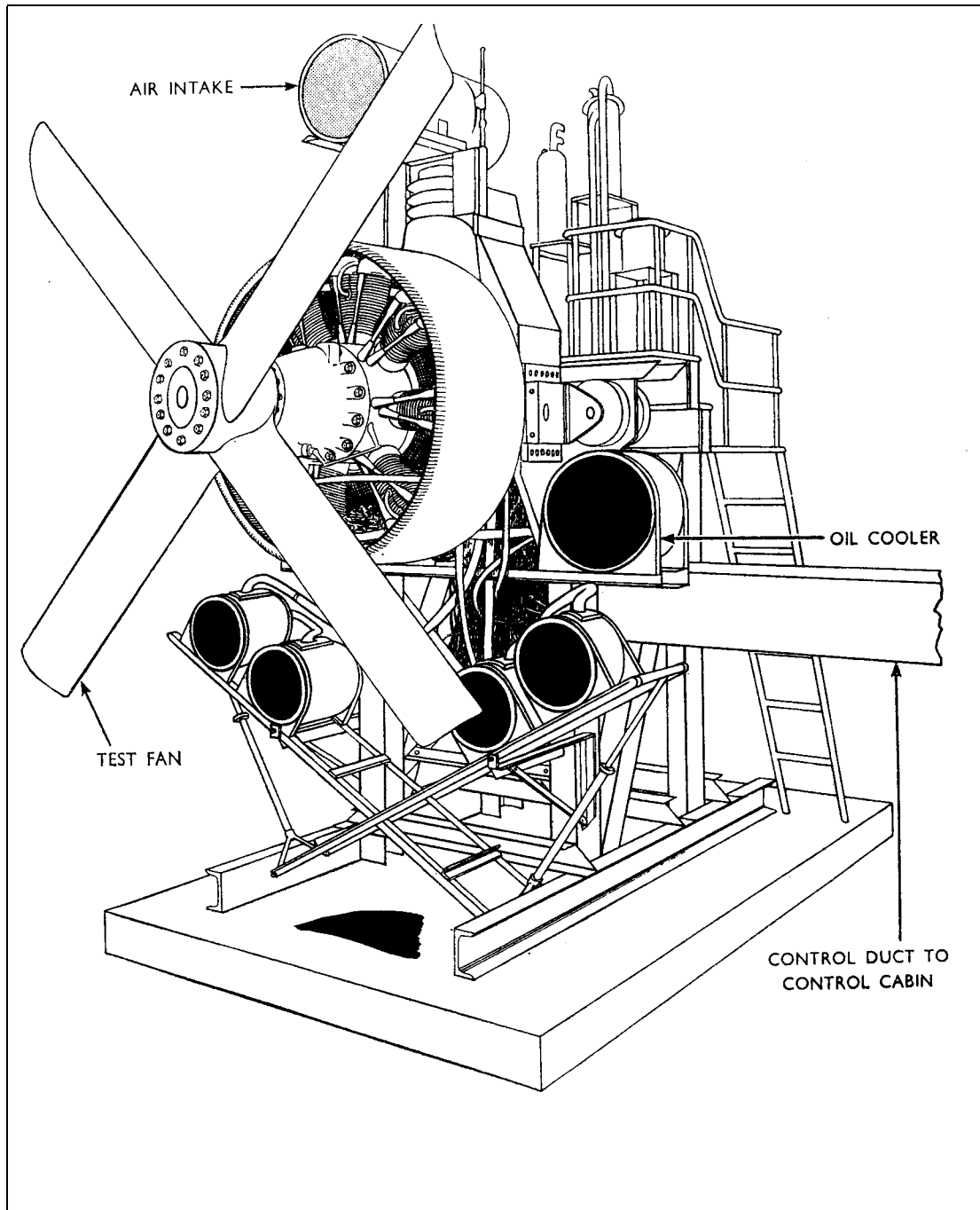

Figure 1 Aero-engine Test Bench For Fan Testing

3 Fan Testing

The fan method of testing an aero-engine consists of running the engine on a test bench with a calibrated test fan fitted instead of a flight propeller, the fan providing the means of loading the engine during the test. To assess the engine power output, the rpm of the overhauled engine when loaded with the test fan must be compared with the rpm which would be developed by the type engine loaded with the same fan and run on the same test bed under the same conditions.

3.1 Test Plant

The engine to be tested should be mounted on a test bench which should be provided with the complete oil, fuel and electrical systems required for starting and running the engine and, in the case of supercharged engines, with equipment for reducing the pressure of the air supplied to the engine intake so that altitude conditions can be simulated when specified in the engine test schedule. A suitable type of test bench for small engines is shown in Figure 1; it can be adapted for either radial or in-line engines. Whichever type of engine is fitted, adequate provision must be made for cooling it. This may necessitate fitting an oversize cooling scoop to in-line engines. Testing should normally be done in a specially designed building, preferably located so that the engines under test inhale air which is free from excess moisture or industrial contaminants. However, some test stands for the testing of small engines are of a mobile type and, in favourable atmospheric conditions, may be used in the open air.

3.2 Test Instruments

The test bench should be equipped with an approved range of instruments to enable accurate indication of the relevant test data specified in the test schedule appropriate to the engine. The instruments and all measuring equipment should be calibrated prior to fan calibration and should afterwards be checked for accuracy at regular intervals. An additional revolution counter which will serve as a master for checking the continuous reading rpm indicator should also be available; an instrument approved for this purpose is the 'Hasler', which is a hand-held indicator of great accuracy incorporating its own chronometer. The following continuous reading instruments are usually required for the testing of small air-cooled engines:

Instrument	Calibration
1 Engine speed indicator	rpm
2 Manifold pressure gauge	kN/m ² or kPa (inHg)
3 Main oil pressure gauge	kN/m ² or kPa (lbf/in ²)
4 Auxiliary oil pressure gauge	kN/m ² or kPa (lbf/in ²)
5 Pump inlet oil pressure gauge	kN/m ² or kPa (lbf/in ²)
6 Fuel pressure gauge	kN/m ² or kPa (lbf/in ²)
7 Oil temperature gauges (inlet and outlet temperatures)	°C
8 Cooling air temperature gauge	°C
9 Cooling air speed indicator (or cooling air differential pressure gauge)	m/s or kN/m ² (mile/h or inH ₂ O)
10 Stop watch for checking oil circulation rate	Seconds
11 Cylinder head temperature gauge	°C
12 Fuel flowmeter	kg/h or litre/h (lb/h or pints/h)
13 Air intake temperature gauge	°C

14 Exhaust back pressure gauge	kN/m ² or kPa (lbf/in ²)
15 Test house barometer	kN/m ² or kPa (inHg)
16 Air intake pressure gauge	kN/m ² or kPa (inHg)
17 Fan air temperature gauge	°C

3.3 Test Plant Oil System

The instructions given in Leaflet 70-50 for cleaning and heating test bench oil systems and for measuring oil consumption and oil circulation are also applicable when an engine is to be tested with a fan.

3.4 Instrument and Pipe Connections

The provisions of paragraphs 3.8, 3.9 and 3.10 of Leaflet 70-50 are also applicable when an engine is to be tested with a fan.

4 Choice of Test Fan

The type of test fan to be used when testing a particular type of engine must have been permitted by the engine manufacturer; the criteria determining the choice include the power dispersal characteristics of the fan, the ability to withstand the blade stresses imposed during prolonged bench running and the cooling requirements of the engine. There are two main groups of fans: fixed-pitch fans and variable-pitch fans controlled by a constant-speed governor.

4.1 Fixed-pitch Test Fans

Fixed-pitch fans may be sub-divided into two types: those which have one pitch that cannot be altered and those which have an adjustable pitch which can be locked at predetermined pitch settings. These two types of fans are usually designed and calibrated to absorb the Maximum Continuous Power of the engine when it is running at Maximum Continuous rpm under standard sea-level conditions and it is also essential that they should not allow the engine to overspeed at the Maximum Take-off manifold pressure.

4.1.1 Fans with unalterable pitch settings are specially made with square-tipped blades of laminated wood manufacture. The blades are made wide to provide maximum power absorption and maximum engine cooling with minimum blade tip diameter. Because design limitations and variations in test conditions make it impossible to predetermine the exact diameter required to absorb a given power, the blades are supplied oversize and have to be individually calibrated by successively removing material from the blade tips until the required power absorption is obtained. This operation is known as 'cropping'.

4.1.2 To crop a fan, thin slices are sawn from the tips of each wooden blade, care being taken to ensure that equal amounts are removed from each tip and that all sharp corners are rounded off. After each cropping, the fan must be rebalanced before it is replaced on the engine. On completion of cropping, the cropped blades should be protected against deterioration by applying the approved finish to the bare ends. If the blades are overcropped by a small amount, or are found to be absorbing too little power for any other reason, it may be permissible to make the fan 'heavy' by adding spoilers to the blades. The advice of the fan manufacturer should be sought on the method of spoiling appropriate to a particular type of fan.

- 4.1.3 The power absorption characteristics of a fixed-pitch fan with adjustable-pitch settings are varied by altering the pitch of the blades. The blade pitch is usually altered by resetting stops incorporated in the hub of the fan and these should be adjusted in accordance with the instructions of the manufacturer of the fan. If the rpm obtained during calibration are too high, the blades should be moved towards coarse pitch; if the rpm are too low, they should be moved towards fine pitch.

4.2 **Variable-pitch Test Fans**

Variable-pitch test fans controlled by a constant-speed governor can be operated at a fixed, predetermined position, e.g. on the fine or coarse pitch stop and also at variable settings under the control of the governor. Fans of this type are calibrated by adjusting their pitch stops so that the power of the engine at Maximum Take-off manifold pressure is absorbed without over-speeding when the engine is running under standard sea-level conditions. Such fans must also be able to absorb the Maximum Continuous engine power when constant speeding or running against a stop with the engine running under Maximum Continuous conditions.

4.3 **Flight Propellers**

A flight propeller may be approved as a test fan if the engine cooling provided is adequate and the propeller is able to withstand the more severe stresses which occur in the blades when operated under static instead of flight conditions. Once a metal flight propeller has been used as a test fan it must not again be used for flight purposes.

NOTE: Experience has shown that, unless a cable-suspended test rig is used, metal flight propellers are seldom satisfactory for prolonged test bed running.

4.4 **Method of Determining Fan Type Required**

If doubt exists as to whether a fixed-pitch or variable-pitch fan should be used for a particular engine type, the following method of determination may be used.

4.4.1 **Unsupercharged Engines**

The power/rpm curve at full throttle under standard sea-level conditions should be copied from the Engine Technical Certificate and marked at points corresponding to 90% and 97% of the maximum rpm. As shown in Figure 2, the point of Maximum Continuous power and rpm (the calibration point) should also be marked and a fan power absorption curve should be drawn through it to cut the full throttle curve. The fan power absorption curve is drawn on the assumption that the power varies with the cube of the rpm. The rpm indicated at the point of intersection of the two curves should lie between 90% to 97% of the maximum rpm. If it fails to do so, the point of Maximum Continuous power and rpm may be adjusted by $\pm 2\%$ of the rpm value and a cube law curve may be drawn through this adjusted point. If it is possible to bring the absorption curve to intersect the full throttle curve between the 90% to 97% rpm range by the $\pm 2\%$ adjustment, the engine may be tested with a fixed-pitch fan; if not, a variable-pitch fan should be used.

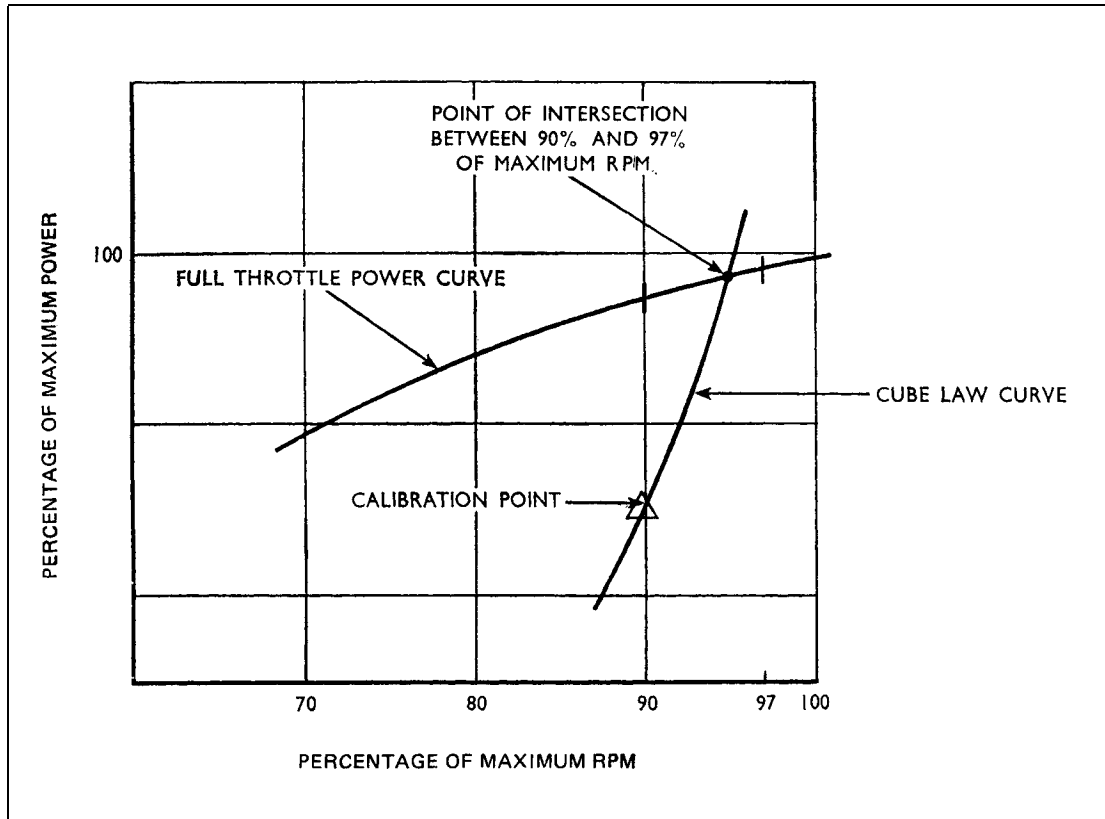

Figure 2 Determination of Type of Test Fan Required for an Unsupercharged Engine

4.4.2 Supercharged Engines

The procedure for supercharged engines with single speed superchargers is similar to that given in paragraph 4.4.1, except that the power/rpm curve at Maximum Take-off manifold pressure should be the curve obtained from the Engine Technical Certificate. Points corresponding to 90% and 97% of the maximum rpm should be marked on the Take-off power curve and the power absorption curve, originating from the point of Maximum Continuous Power and rpm (the calibration point) should be drawn to intersect this power curve. If, after an adjustment of $\pm 2\%$ of the rpm value, the intersection of the two curves fails to be between 90% and 97% of the maximum rpm, a fixed-pitch fan would be unsuitable for the test.

4.4.3 Variable-Pitch Fan Settings

If the procedure given in paragraph 4.4.1 or 4.4.2, as appropriate, indicates that a fixed-pitch fan is unsuitable, a variable-pitch fan should be used. For the power check, one pitch stop of the variable-pitch fan should be set so that 97% of the Maximum Take-off rpm is obtained when running against this stop at Maximum Take-off manifold pressure (see Figure 3). To achieve this, separate engine runs should be made at Maximum Take-off manifold pressure to establish the speeds obtainable with the fan on its fine and coarse pitch stops respectively. The rpm obtained on each run should be marked on the Take-off power curve as an indication as to which stop, after adjustment, will give the fan pitch resulting in a fan power absorption curve passing through the 97% rpm point on the power curve. If the coarse pitch stop is used, the constant-speed unit (CSU) is set to the minimum rpm position and the fan will constant speed for a point below the absorption curve. If the fine pitch stop is

used, the CSU control is set to the maximum rpm position and the fan will then constant speed for a point above the curve.

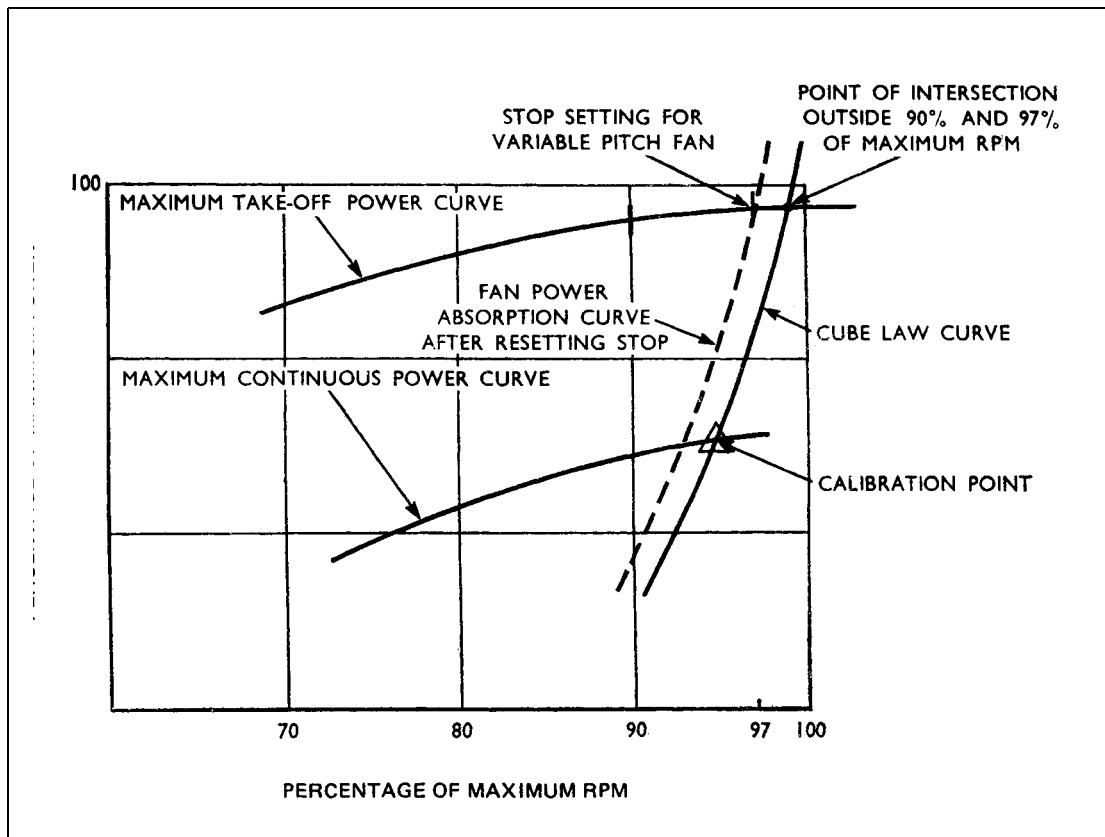

Figure 3 Determination of Type of Test Fan and Pitch Setting Required for a Supercharged Engine

5 Fan Calibration

Before being used for testing overhauled engines, each test fan on each site must be calibrated on a new or recently reconditioned engine (hereinafter referred to as the 'calibrated engine') which has not been run to any extent since its power output was last determined, for the purpose of fan calibration, on a dynamometer test bench. The calibration of the fan must be performed in the test cell in which the overhauled engines are to be tested and unless it can be shown that changing from one test bench to another has no effect on fan performance, a separate calibration should be made each time the fan is used on a different bench. For preference the fan should be calibrated when the wind is unlikely to have any appreciable effect on results, but, if tests must be made when a strong wind is blowing, appropriate corrections may be made. The correction factors applied must be agreed with the engine manufacturer.

- 5.1 For an unsupercharged engine, the Full Throttle power curve of the calibrated engine must be available. In the case of a supercharged engine, the Maximum Take-off and Maximum Continuous constant manifold pressure curves, at standard sea-level atmospheric conditions, are required. An approved Test Fan Calibration Schedule for the engine type (obtainable from the engine manufacturers and normally included in the Engine Test Schedule), the power curves for the engine type (obtainable from the Engine Technical Certificate) and the appropriate correction curves (see Leaflet 70-70), must also be available.

- 5.2 Before commencing fan calibration, it is advisable to use an old engine to enable the test bed to be correctly set up. The calibrated engine should then be mounted on the test bench and primed with warm engine oil (see paragraph 7.1). The manufacturer may specify that a special cooling airscoop should be fitted for test bed running.
- 5.3 When a test fan is being calibrated, the engine temperatures and pressures should be as near as possible to those recorded when the engine was calibrated on the dynamometer.
- 5.4 The test fan power absorption characteristics are presented in the form of a cube law curve drawn on the assumption that, under constant atmospheric conditions, the power absorbed varies as the cube of the rpm. Consequently, if the power to be absorbed by the fan at one particular engine speed is known, a cube law curve showing the power/rpm relationship over a range of speeds may be drawn from calculated data. If such a curve is drawn through the power it should absorb at a particular speed so as to intersect the appropriate power curve for the calibrated engine, the value of rpm at the intersection is the rpm to be obtained from the fan after its blades have been cropped or its pitch stop finally adjusted.
- 5.5 In practice a tolerance of not more than ± 20 rpm has to be allowed, which necessitates drawing a cube law curve for the fan, after cropping or pitch adjustment, which is based on rpm values derived from the observed results corrected to standard sea-level conditions. The intersection of the actual fan power absorption curve and the appropriate engine power curve for the type engine then gives the 'acceptance rpm' value for the test fan. The corrected values subsequently attained when overhauled engines are tested with the same fan on the same test bed should not be less than 98% of these values.
- 5.6 The acceptance rpm of the test fan on the particular test bed should be recorded and used as a reference whenever the fan is used for testing. At intervals, each test fan should be weighed, its static balance should be checked, the blade angles should be measured at specified stations and the general condition of the fan should be assessed. At longer agreed periods and whenever any change in the environment of the test cell is made or whenever distortion of the fan blades is suspected, the acceptance rpm should be re-checked by a repeat calibration.

6 Fan Calibration Procedure

The procedure for calibrating a test fan for use in testing a particular type of engine varies according to whether the engine is supercharged or unsupercharged. In practice a specific method to suit the characteristics of each type of engine is recommended by the engine manufacturer and is included in the approved Engine Test Fan Calibration Schedule. The approved method must be used at all times, but an outline of the general principles of calibration procedure is given in the following paragraphs. Whilst the specimen procedures given are typical, they are not necessarily generally applicable to all engine types.

6.1 Unsupercharged Engines

Unsupercharged engines are generally tested with fixed-pitch fans and a typical calibration procedure is as follows:

- 6.1.1 Draw the power/rpm curves at full throttle for the calibrated engine and for the type engine, as shown in Figure 4.
- 6.1.2 Plot on the graph the test fan calibration point (obtained from data supplied by the engine manufacturer) and through it draw a cube law curve representing the power

absorption characteristics of the fan. Extend this curve as necessary to intersect the full throttle curve for the calibrated engine. The point of intersection gives the corrected rpm to be attained, subject to a tolerance of ± 20 rpm, when the test fan has been adjusted and the calibrated engine is running at full throttle.

EXAMPLE: If the calibration point is 142 kW at 2100 rpm, mark this point on the graph and then plot further points obtained by incremental increases of power and rpm. Since the power absorbed by the fan is assumed to increase with the cube of the rpm, the increments of power increase should be cubed thus:

$$142 \times 1.1^3 \text{ against } 2100 \times 1.1 = 189 \text{ kW}/2310 \text{ rpm}$$

and 142×1.2^3 against $2100 \times 1.2 = 245.4 \text{ kW}/2520 \text{ rpm}$

The cube law curve is a line drawn from the calibration point through the points plotted to the full throttle curve of the calibrated engine.

- 6.1.3 The temperature correction chart (Leaflet 70-70) should now be used to find the corresponding value of rpm which should be obtained in the actual conditions of fan air temperature prevailing at the site.
- 6.1.4 With the calibrated engine fitted with the test fan and installed on the test bench in the cell for which the calibration is required, the engine should be run until normal running conditions have stabilised. It should then be opened up to full throttle and careful note taken of the rpm obtained. The rpm observed on the continuous reading rpm indicator should be cross-checked by means of the 'Hasler' indicator.
- 6.1.5 To obtain the value of rpm determined by the method given in paragraph 6.1.3 (within ± 20 rpm), the fan should be removed and the blades cropped or the pitch adjusted as necessary. This should be done in successive stages with trial runs and, in the case of cropped propellers, rebalancing between each stage. If a cropped test fan gives a higher speed than that aimed at, it should be made 'heavy' in the manner approved by the fan manufacturer.
- 6.1.6 The fan should then be remounted on the engine and the engine should again be run at full throttle. When the required rpm are obtained, the observed values should be recorded. To obtain reliable results, two or three separate runs should be made and on each occasion the mean of three readings taken in stabilised conditions at 1 minute intervals should be taken as the observed rpm. The mean of the observed rpm readings should then be corrected to standard temperature conditions by means of the appropriate chart and the corrected value should be plotted on the full throttle curve for the calibrated engine. In the example shown in Figure 4, the rpm are higher than the value aimed at but are within the tolerance.
- 6.1.7 A cube law curve should now be drawn to pass through the point plotted by the method given in paragraph 6.1.6 for the corrected value of rpm. This curve should be extended as necessary to intersect the full throttle curve for the type engine and the point of intersection will give the acceptance rpm of the fan. This value should be recorded together with details of the direction and speed of the wind at the time of calibration. A report on the calibration, including details of the environment in which the fan was tested and the acceptance rpm established for it, should be compiled for record purposes.

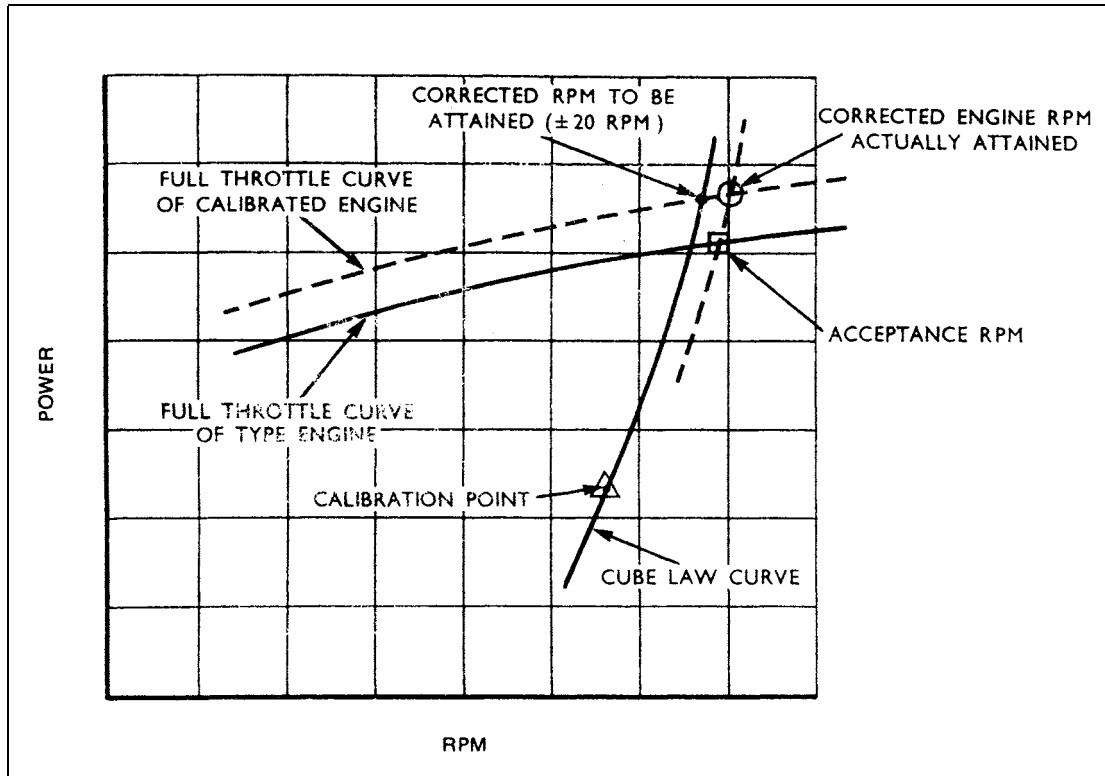

Figure 4 Calibration of Fixed-pitch Fan Fitted to Unsupercharged Engine

6.2 Supercharged Engines

Engines with single-speed superchargers are tested either with fixed-pitch fans or with variable-pitch fans, the type of fan required being determined by the method given in paragraph 4.4. Typical calibration procedure is as follows:

- 6.2.1 Draw the power/rpm curves for constant manifold pressure at Maximum Take-off, Maximum Continuous Power and, if applicable, Maximum Weak Mixture Power for both the calibrated engine and the type engine, as shown in Figure 5.
- 6.2.2 For a fixed-pitch fan, plot on the graph the test fan calibration point (normally the point of Maximum Continuous power and rpm) and through it draw a cube law curve representing the power absorption characteristics of the fan. For a variable-pitch fan with governor control, plot the 97% rpm point of the type engine, as determined by paragraph 4.4.3 and draw the cube law curve through it. Extend the cube law curve as necessary to intersect the Maximum Take-off, Maximum Continuous Power and Maximum Weak Mixture constant manifold pressure curves for the calibrated engine. The point of intersection with the Maximum Take-off constant manifold pressure curve gives the corrected rpm to be attained, subject to a tolerance of ± 20 rpm, when the test fan has been adjusted and the calibrated engine is running at the Maximum Take-off manifold pressure on a standard day.
- 6.2.3 The appropriate correction chart (Leaflet 70-70) should now be used to find the corresponding values of rpm to be obtained in the actual conditions of fan air temperature and atmospheric pressure prevailing at the site.
- 6.2.4 With the calibrated engine installed on the test bench and fitted with the test fan in the cell for which the calibration is required, the engine should be run until normal running conditions have stabilised. It should then be opened up to Take-off manifold

pressure and careful note taken of the rpm obtained. A cross-check should be made by means of the 'Hasler' indicator.

- 6.2.5 To obtain the value of rpm determined by the method given in paragraph 6.2.3 (within ± 20 rpm), the fan should be cropped or the pitch adjusted as necessary. The fan should then be remounted on the engine and the engine should be run at Take-off, Maximum Continuous and Maximum Weak Mixture manifold pressures in turn. Where applicable, the sequence of events for cropping the fan and then running the engine fitted with the calibrated fan, should be the same as in paragraphs 6.1.5 and 6.1.6.
- 6.2.6 The rpm observed when the engine is running with the fan finally adjusted should be corrected to conditions at sea-level on a standard day. The corrected rpm at Take-off manifold pressure should be plotted on the Take-off Power curve for the calibrated engine and the corrected rpm for Maximum Continuous and Maximum Weak Mixture on the appropriate power curves. These points should be linked by a test fan power absorption curve of approximately cube law form drawn through them.

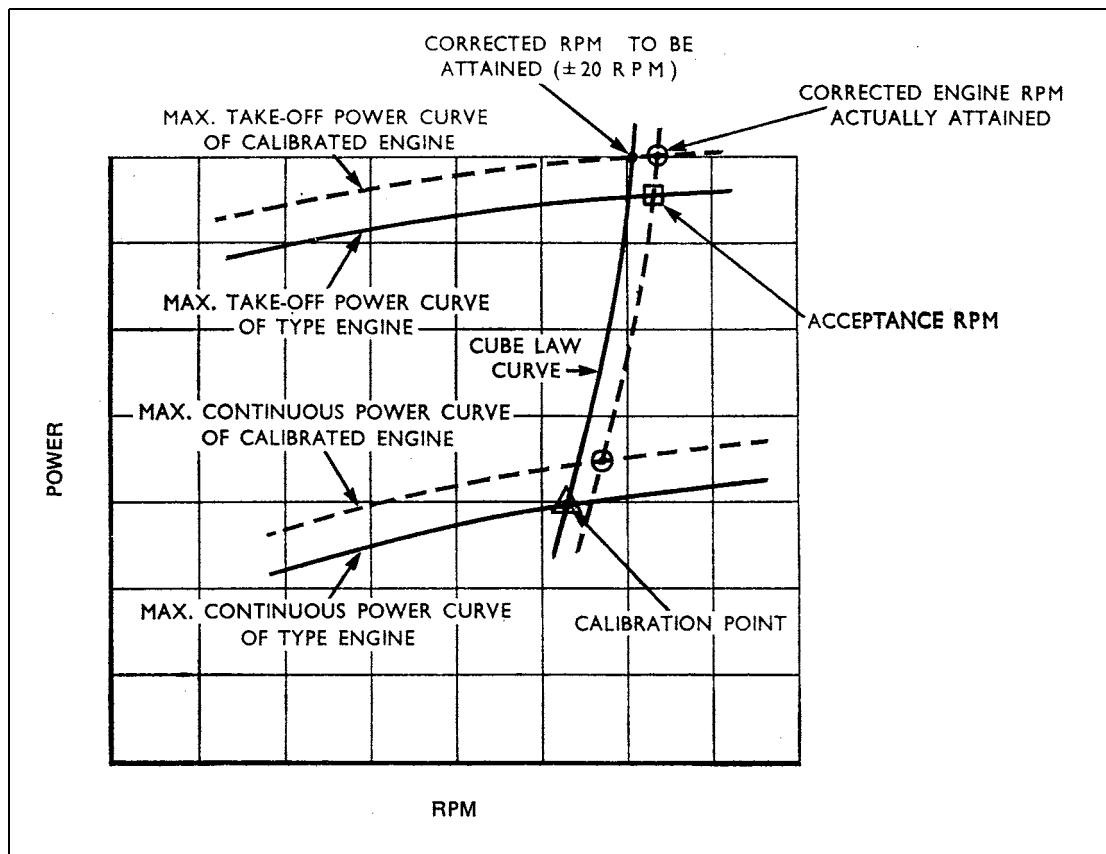

Figure 5 Calibration of Fixed-pitch Fan Fitted to Supercharged Engine

- 6.2.7 The fan power absorption curve should be extended as necessary to cut the Maximum Take-off Power curve for the type engine. The point of intersection gives the acceptance rpm of the fan. The points where the fan power absorption curve cuts the Maximum Continuous and Maximum Weak Mixture curves give rpm datum points which may be used, as recommended by the engine manufacturer, for engine tuning. These values should be recorded, together with details of the direction and speed of the wind at the time of the calibration. A report on the calibration, including details of the environment in which the fan was tested and the acceptance rpm established for it, should be compiled for record purposes.

7 Using the Calibrated Fan

After calibration, a test fan should only be used to test engines of the type for which it has been calibrated and in the particular cell in which the calibration has been made. If the environmental conditions of the test cell are changed, the fan must be recalibrated. The overhauled engine to be tested should be mounted on the test bench within the cell and the calibrated fan should be assembled to it: the engine should then be run according to the approved Test Schedule appropriate to the type of engine.

- 7.1 Before starting the engine, its lubrication system should be primed with warm engine oil. The oil should be fed in under pressure whilst the engine is turned over by hand, care being taken to ensure that the oil is completely distributed through the bearings, gears and accessories drives. Should the engine not be run within three hours of priming it should be reprimed.
- 7.2 The engine should be correctly adjusted before the commencement of the test and a check should be made that the test plant controls have been correctly assembled. In the case of supercharged engines, the regulating valve of the depression box on the air intake should be fully open; in the case of normally-aspirated engines no depression box should be fitted.
- 7.3 After starting, the engine should be run-in according to the instructions in the Test Schedule approved for the engine type. Running-in is Stage 1 of the Endurance Test and the other stages should then follow in the sequence prescribed. During the test a suitable position for the thermometer which records the temperature of the air passing through the fan should be determined; a position between 2.5 to 4 metres (8 to 12 feet) forward of the engine and outside the arc of the fan usually proves satisfactory.

8 Acceptance Conditions

The acceptance conditions for overhauled engines when tested with a fan and the performance corrections to be made are defined in the appropriate approved engine test schedule. The specific standards of performance defined must be achieved to permit pass-off.

9 Performance Corrections

- 9.1 The corrections used in order to convert the observed engine rpm to standard atmospheric conditions at sea-level and to assess the performance of the supercharger where applicable, shall be carried out in accordance with approved data.
- 9.2 For the rpm correction the variation of power with rpm at Maximum Take-off manifold pressure (and at Maximum Climbing or Maximum Continuous manifold pressure in any other supercharger gears) shall be established and a chart giving the correction factor for a suitable range of atmospheric conditions shall be prepared. If variations in wind speed and direction can appreciably affect the power absorption characteristics of a fan in a particular test cell, suitable corrections may be established, but before being used they shall be agreed with the manufacturer.

Leaflet 70-70 Piston Engine Overhaul – Correcting Engine Test Results

1 Introduction

- 1.1 Performance results obtained during the bench testing of aero-engines must be corrected to the conditions of temperature and pressure in the standard atmosphere. Correction formulæ which are applicable to the testing of low-power, air-cooled engines are normally provided in manufacturer's manuals. In the absence of such information the methods described in this Leaflet may be used. Other parts of the Requirements relevant to testing piston engines after overhaul are repeated in CAAIP Leaflets 70-50 and 70-60.
- 1.2 This Leaflet also explains how to make corrections for the effects of prevailing atmospheric conditions during the calibration of test fans, and includes charts which may be used to make such corrections.
- 1.3 This Leaflet should be read in conjunction with CAAIP Leaflets 70-50 and 70-60.

2 General

Varying atmospheric conditions affect engine performance by an appreciable amount and corrections must therefore be made for deviations of atmospheric pressure and temperature from standard at the time of test. Humidity changes, whilst not generally as significant as pressure or temperature changes, also have an influence on the results and therefore a method of correcting for humidity is given in paragraph 3.3. If the engine power is affected by deviation of cylinder temperature from the values prescribed in the test schedules, appropriate corrections may also be made, but the corrections must be approved by the CAA before use in the calculations.

3 Engines Tested with a Dynamometer

When an engine is tested on a dynamometer test bench, the brake power is obtained from the products of the net weight lifted by the dynamometer and the rotational speed of the dynamometer rotor, divided by the dynamometer constant (Leaflet 70-50). This gives the observed brake power for the engine (power) and represents the particular power output of the engine under the conditions of air intake temperature, atmospheric pressure, engine manifold pressure and exhaust back pressure at the time of test. To ensure that the power of an engine is within the acceptance limits for the engine type, these results must be corrected to conditions which are standardised for all tested engines, namely to the sea-level conditions of pressure and temperature in the standard atmosphere. These are 101.325 kN/m² (29.92 inHg) and 15°C respectively.

3.1 Power Correction Formulæ

The corrected brake power, P (BHP), of normally aspirated engines and supercharged engines in which there is no provision for inter-cooling, after-cooling or heating the charge before it enters the cylinders, is given by the formulæ:

SI Units

Non-SI Units

$$P_c = P_o \frac{(400 + t_o) \left(M_c - \frac{P_c}{R} \right)}{(400 + t_c) \left(M_o - \frac{P_o}{R} \right)}$$

$$\text{BHP}_c = \text{BHP}_o \frac{(400 + t_o) \left(M_c - \frac{P_c}{R} \right)}{(400 + t_c) \left(M_o - \frac{P_o}{R} \right)}$$

where P(BHP) = brake power, kW (horsepower)

t = air intake temperature, °C

M = manifold pressure, kN/m² (inHg)

p = exhaust back pressure, kN/m² (inHg) = atmospheric pressure + any increase in pressure due to the test plant exhaust system. (In the examples given p is assumed to be equal to atmospheric pressure)

R = engine compression ratio

Friction Power (P_f or FHP) is given by the formulæ:

SI Units

Non-SI Units

$$P_f = 27 \times 10^{-16} \times N^2 \times d^2 \times l^2 \times n$$

$$\text{FHP} = 15 \times 10^{-10} \times N^2 \times d^2 \times l^2 \times n$$

where N = crankshaft rotational speed, rpm

d = cylinder bore, mm (in)

l = length of stroke, mm (in)

n = number of cylinders

Suffix 'o' denotes an observed condition, corrected for instrument error only.

Suffix 'c' denotes the condition in the required (sea-level atmospheric) atmosphere.

- NOTES:**
- 1) Standard sea-level atmospheric pressure = $1.01325 \times \text{N/m}^2 = 1013.2 \text{ mbar} = 29.92 \text{ inHg} = 760 \text{ mmHg} = 14.7 \text{ lbf/in}^2$.
 - 2) $1 \text{ kN/m}^2 = 1 \text{ kPa} = 10 \text{ mbar}$.
 - 3) $1 \text{ lbf/in}^2 = 6.895 \text{ kN/m}^2$.
 - 4) $1 \text{ inHg} = 3.386 \text{ kN/m}^2$.

3.1.1 Unsupercharged Engines

For an unsupercharged engine running at constant rpm at full throttle, the manifold pressure is normally assumed to be atmospheric, which means that to correct the observed power to sea-level conditions the formulæ can be written as follows:

SI Units

Non-SI Units

$$P_c = P_o \frac{(400 + t_o) \left(101.325 - \frac{101.325}{R} \right)}{(400 + t_c) \left(P_o - \frac{P_o}{R} \right)} \quad \text{BHP}_c = \text{BHP}_o \frac{(400 + t_o) \left(29.92 - \frac{29.92}{R} \right)}{(400 + t_c) \left(P_o - \frac{P_o}{R} \right)}$$

EXAMPLE: If the full-throttle brake power of a particular engine (compression ratio 5.25:1) is observed to be 196 kW on a day when the air temperature is 17°C and barometric pressure is 1000 mbar (100 kN/m²), then corrected to standard sea-level conditions the brake power would be:

$$P_c = 196 \frac{(400 + 17) \left(101.325 - \frac{101.325}{R} \right)}{(400 + 15) \left(100 - \frac{100}{R} \right)}$$

$$= 196 \times 1.005 \times 1.013$$

$$= \mathbf{199.54 \text{ kW}}$$

NOTE: Assuming the declared Maximum Take-off Power of the engine is 196 to 204 kW at sea-level, the result satisfies the acceptance conditions.

3.1.2 Supercharged Engines

During the Endurance and Final Tests of a supercharged engine, the power output and the supercharger compression ratio are measured, the former with an unrestricted air intake and the latter with a restricted intake obtained by using a depression box fitted to the intake.

a) **Power.** When correcting the power observed during a test run with unrestricted air intake to standard sea-level conditions at the same manifold pressure, the correction formula can be written:

SI Units

Non-SI Units

$$P_c = P_o \frac{(400 + t_o) \left(M_c - \frac{101.325}{R} \right)}{(400 + 15) \left(M_o - \frac{P_o}{R} \right)} \quad \text{BHP}_c = \text{BHP}_o \frac{(400 + t_o) \left(M_c - \frac{29.92}{R} \right)}{(400 + 15) \left(M_o - \frac{P_o}{R} \right)}$$

EXAMPLE: If the brake power of a particular engine, having a compression ratio of 6.5:1 and running at a manifold pressure of 41.3 inHg (140 kN/m²) is observed to be 348.5 kW on a day when the air intake temperature is 20°C and the barometric pressure is 1010 mbar (101 kN/m²), the corrected brake power will be:

$$P_c = 348.5 \frac{(400 + 20) \left(140 - \frac{101.325}{6.5} \right)}{(400 + 15) \left(140 - \frac{101}{6.5} \right)}$$

$$= 348.5 \times 1.012 \times 0.999$$

$$= \mathbf{352.329 \text{ kW}}$$

b) **Supercharger Compression Ratio.** The variation of supercharger compression ratio with variation of air temperature at constant air intake pressure is given by:

$r_c = r_o (1 + k (t_o - t_c))$ when correcting to a lower air temperature

and $r_c = \frac{r_o}{1 + k(t_c - t_o)}$ when correcting to a higher air temperature

In the above formulæ the additional notation is used:

r = supercharger compression ratio

k = supercharger temperature constant for particular engine.

The supercharger compression ratio is determined during Stages 8 and 9 of each test by running the engine with the air intake restricted such that the throttle is fully open at Maximum Continuous (or Maximum Climbing) Power and at Take-off Power conditions respectively. With the throttle lever set to obtain the appropriate manifold pressure, the regulating valve on the intake depression box should be closed progressively until the boost control has fully opened the throttle. The corresponding air intake pressure should be found (see paragraph 4.3.1), and should then be corrected to sea-level temperature conditions in the standard atmosphere by means of the appropriate formula.

EXAMPLE: If when testing the above engine the observed manifold pressure at Maximum Continuous Power conditions is 140 kN/m^2 and the observed air intake pressure is 101 kN/m^2 , the compression ratio will be:

$$r_o = \frac{M_o}{P_o} = \frac{140}{101} = 1.386$$

Assuming the value of 'k' for this engine is 0.001 under test conditions where the intake temperature is 20°C , the supercharger compression ratio corrected to the sea-level temperature of a standard day will be:

$$r_c = 1.386 [1 + 0.001 (20 - 15)] = 1.386 \times 1.005 = \mathbf{1.392}$$

NOTE: Since the sum of the ratios of the corrected sea-level power and the corrected supercharger compression ratio to the values established in the Engine Technical Certificate is greater than 1.96, the results satisfy the acceptance conditions prescribed.

$$\text{i.e. } \frac{352.329}{351} + \frac{1.392}{1.4} = 1.004 + 0.994 = \mathbf{1.998}$$

3.2 Power at Altitude

3.2.1 When drawn on a relative density basis the variation of power with altitude at constant crankshaft rotational speed and manifold pressure may be given by a straight line between the power at sea-level and the power at the full throttle height.

3.2.2 The variation of power with height at constant crankshaft rotational speed and full throttle, when drawn on a relative density basis, may be a curve at high powers but at low powers this curve may be extended as a straight line to the negative friction horsepower at zero density.

3.3 Humidity Corrections

In order to determine power ratings in dry air, or conversely to determine the power output in given conditions of atmospheric humidity, the following corrections should be used unless more accurate data are available:

SI Units

$$P_c = \frac{P_o + P_f}{1 - xh} - P_f$$

Non-SI Units

$$\text{BHP}_c = \frac{\text{BHP}_o + \text{FHP}}{1 - xh} - \text{FHP}$$

where x is a factor depending on mixture strength

and h is the humidity, i.e. $\frac{\text{water vapour strength}}{\text{barometric pressure}}$

NOTE: Since the effect of free water on power output is within $\pm 1\%$ over the range of water/air ratios normally encountered in operation, and the amount of free water is exceedingly difficult to measure, no corrections for free water need be made.

3.3.1 For constant fuel flow, the effect of humidity on air/fuel ratio is given by:

$$Z_c = \frac{Z_o}{1 - h}$$

where Z = air/fuel ratio.

3.3.2 Table 1 gives values of x over a range of air/fuel ratios corrected to dry air conditions for aircooled engines with fuel-metering systems which compensate for manifold pressure and charge temperature.

Table 1

Air/fuel ratio	9	10	11	12	13	14	15	16
Values of x	2.15	1.80	1.54	1.32	1.18	1.07	1.02	1.00

3.3.3 The following is the temperature correction which should be used in the case of aircooled engines when the above-mentioned corrections for humidity are utilised:

SI Units

$$P_c = \frac{P_o + P_f}{1 + C(t_c - t_o)} - P_f$$

Non-SI Units

$$\text{BHP}_c = \frac{\text{BHP}_o + \text{FHP}}{1 + C(t_c - t_o)} - \text{FHP}$$

where C is a constant determined for the appropriate dry air mixture strength.

3.3.4 Table 2 gives values for C over a range of air/fuel ratios corrected to dry air conditions.

Table 2

Air/fuel ratio	9	10	11	12	13	14	15	16
Values of C	.00167	.00181	.00195	.00207	.00216	.00224	.00226	.00228

The value of C applicable to take-off conditions when water-methanol injection is used is 0.0022.

4 Test Fan Calibration Corrections

During the calibration of engine test fans (Leaflet 70-60), the rpm obtained will be influenced by the conditions of atmospheric temperature and pressure prevailing at the site. Thus cold conditions have two contradictory effects; the engine power tends to increase because of the increased charge density but an increase in rpm is opposed by the increased power absorbed by the fan as a result of the denser air. The net result is that the observed rpm will be lower than under standard sea-level conditions. Corrections of observed rpm to conditions in the standard atmosphere should be made by means of suitable charts; charts suitable for particular engines are

normally included by the manufacturer in the approved Test Schedule for the engine concerned. However, two charts, one for normally-aspirated engines and one for supercharged engines, each of which is suitable for a wide range of engines when testing at altitudes between sea-level and 1000 feet, are included in this Leaflet and the following paragraphs explain their use.

NOTE: If engines are to be tested in cells at altitudes above 1000 feet, specially prepared charts should be requested from the engine manufacturer.

4.1 **Unsupercharged Engines**

4.1.1 When testing unsupercharged engines at full throttle it can be assumed that barometric changes affecting the engine power, and therefore tending to increase or decrease the engine rpm, are counterbalanced by the variation in fan loading. It is therefore necessary to correct for air temperature only and this can be done with the aid of the chart in Figure 1.

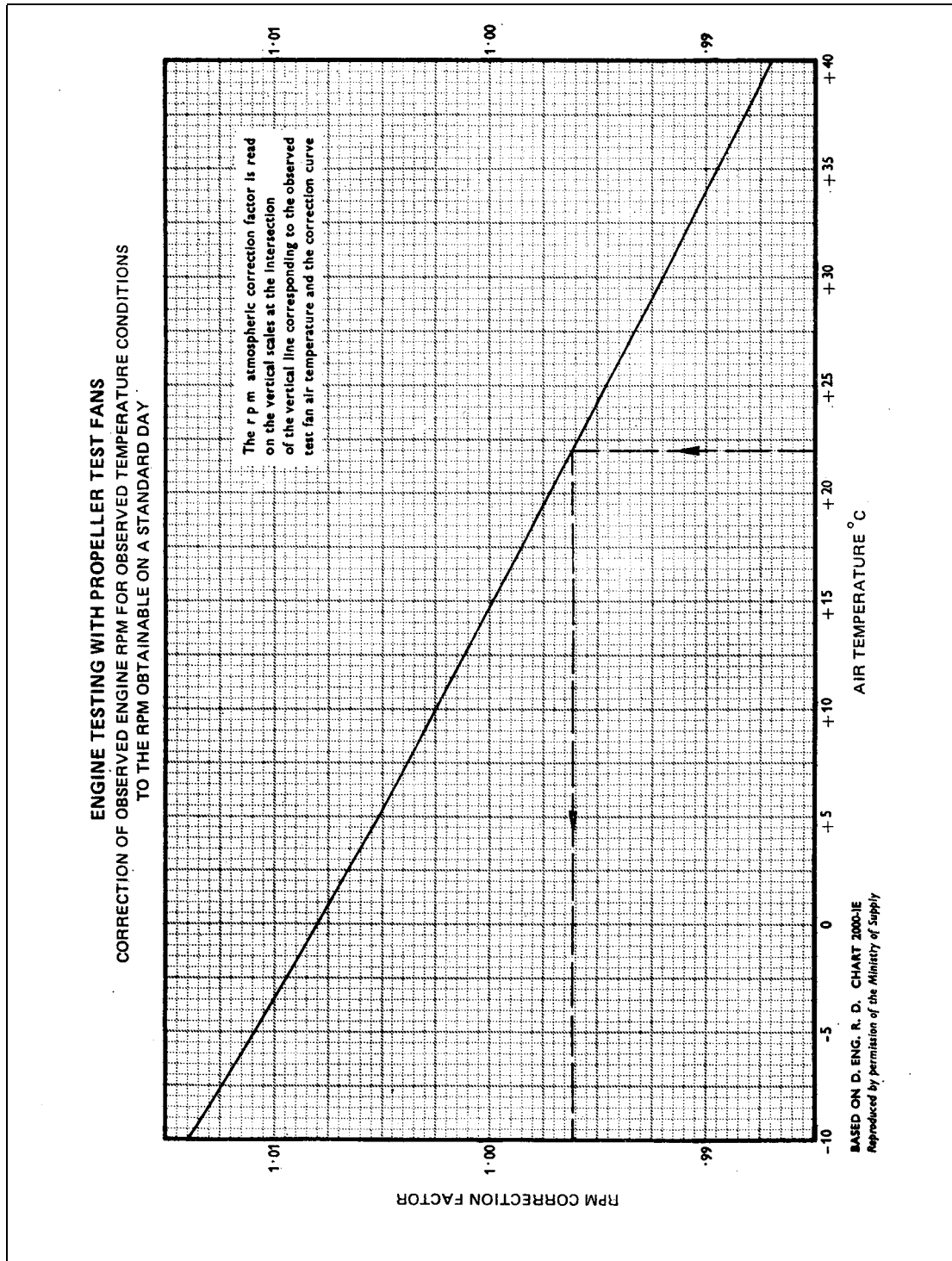

Figure 1

- 4.1.2 To use the chart, a vertical line should be projected from the observed air temperature point on the horizontal scale to the correction curve, and from the point of intersection a horizontal line should be projected to cut the vertical scale. This gives the rpm correction factor by which the observed rpm should be multiplied.

EXAMPLE: If the observed air temperature is +22°C, the rpm correction factor is 0.9962. If the observed rpm is 2650, the corrected rpm = $2650 \times 0.9962 = 2640$.

4.2 Supercharged Engines

4.2.1 When checking the performance of a supercharged engine with a test fan, the engine is run at the required manifold pressure and the effects of barometric changes on engine adjustment are corrected by throttle adjustment. However, the fan loading will vary with the air density and corrections must therefore be made for barometric pressure as well as for air temperature. The fan air temperature, as recorded by the thermometer in the test cell, is assumed to be the same as the air intake temperature. The chart shown in Figure 2 can be used for correcting the rpm of a wide range of air-cooled supercharged engines.

4.2.2 The method of using the chart is to select the point corresponding to the observed barometric pressure on the barometric pressure scale and project a vertical line from this point until it intersects the curve corresponding to the observed air temperature. A horizontal projection from the point of intersection will give the rpm correction factor by which the observed rpm should be multiplied.

EXAMPLE: Referring to Figure 2, if the observed barometric pressure is 104.6 kN/m^2 (30.9 inHg) and the observed air temperature is $+10^\circ\text{C}$, the rpm correction factor is 1.019. If the observed rpm is 2640, the corrected rpm = $2640 \times 1.019 = 2690$.

4.2.3 It sometimes happens that altitude-rated engines reach full throttle before the required manifold pressure can be obtained: either a low full throttle altitude rating, low atmospheric pressure or poor engine performance may be the cause. If, for any reason, a supercharged engine is run at full throttle during the power check (without, of course, exceeding the required manifold pressure), it should be corrected as though it were a normally-aspirated engine by the method given in paragraph 4.1.

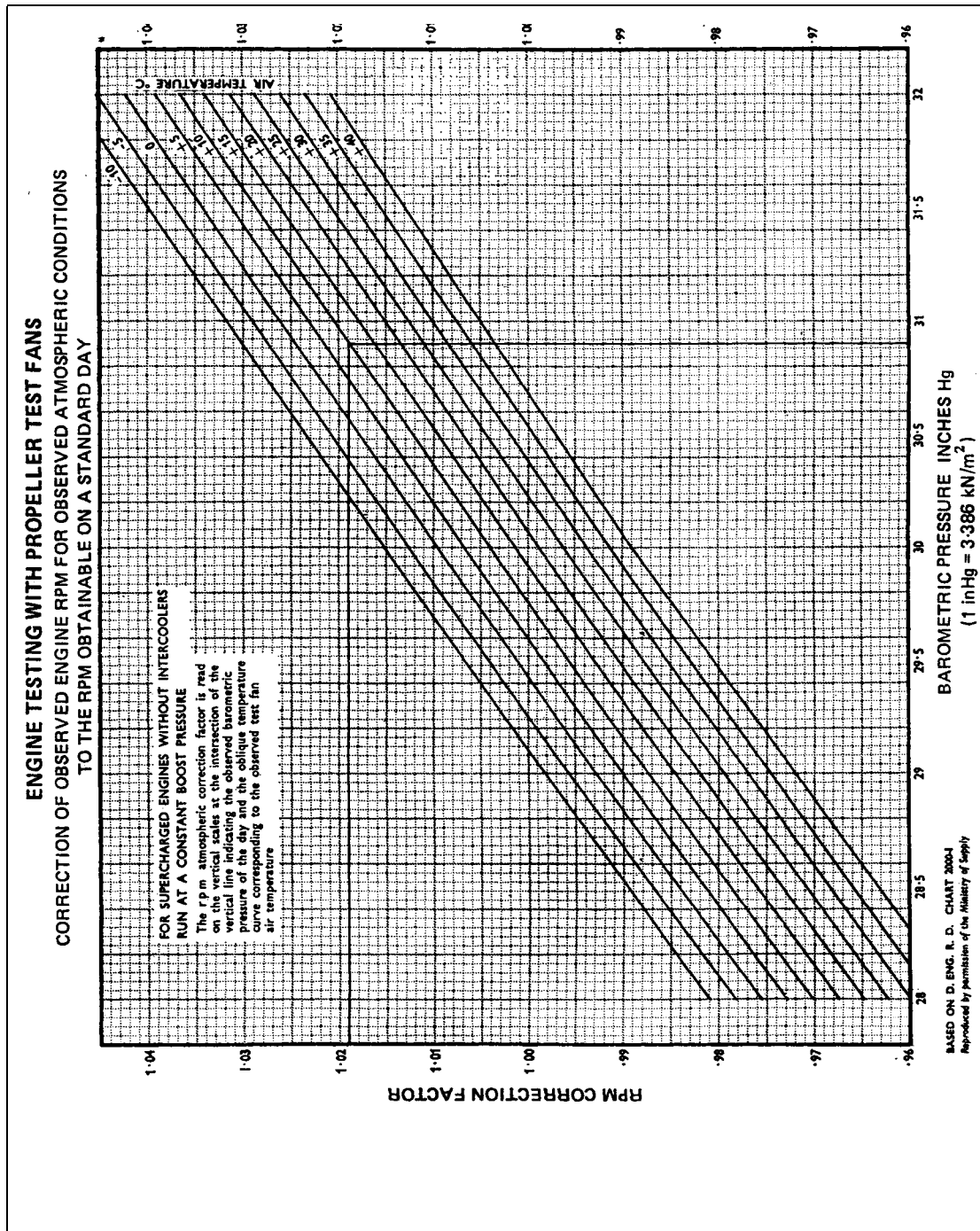
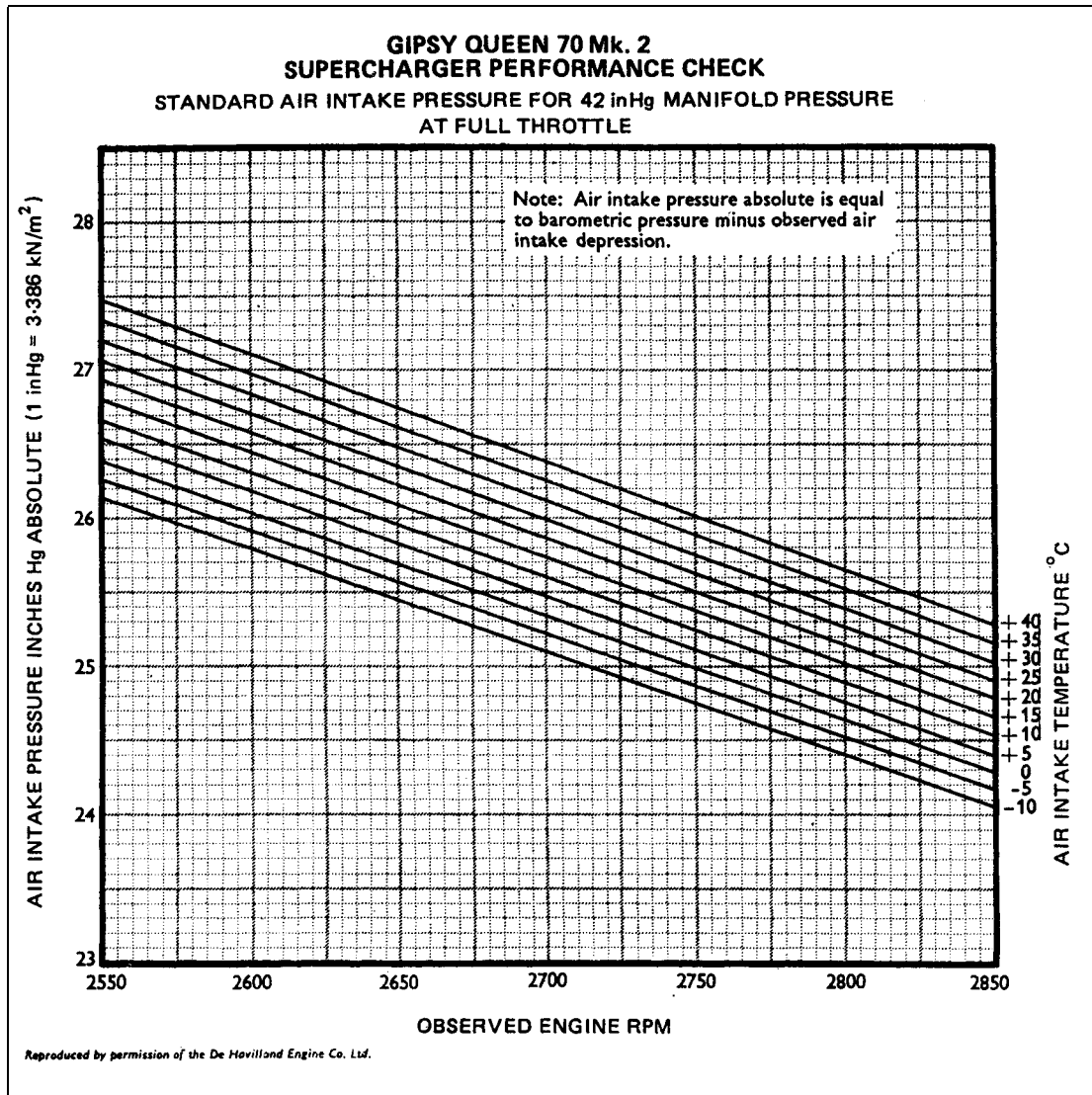

Figure 2

4.3 Supercharger Performance Corrections.

The supercharger performance is checked by running the engine at full throttle at the required rpm and manifold pressure with a restricted air intake and observing the absolute air intake pressure under these conditions. Since the absolute air intake pressure is inversely proportional to the compression ratio, any difference in the ratio from standard will be shown by changes in the intake pressure. The compression ratio of a supercharger varies with the air intake temperature and with the tip speed of the impeller.

**Figure 3**

- 4.3.1 For each particular supercharged engine, it is usual for the engine manufacturer to prepare a supercharger performance correction chart based on the performance of the type-tested engine and to include this chart in the approved Test Schedule for the engine type. From the chart the absolute air intake pressure which should be obtained at the observed rpm and observed intake temperature can be determined. The performance of the supercharger can then be assessed by comparing this pressure with the absolute pressure actually observed in the intake of the engine under test. The observed air intake pressure is taken as the difference between the barometric pressure in the test cell and the pressure indicated on a depression gauge fitted to the depression box.
- 4.3.2 A specimen supercharger performance correction chart is shown in Figure 3; the chart illustrated is for the Gipsy Queen 70 Mk. 2 engine. To find the required absolute air intake pressure, the observed rpm should be read off on the horizontal scale and a vertical line should be projected from it to intersect the curve appropriate to the observed air intake temperature. A horizontal line projected from the point of intersection will give the absolute air intake pressure in inches of mercury.

- 4.3.3 If the observed absolute air intake pressure is greater than the figure obtained from the chart, the supercharger performance is below the performance of the supercharger of the standard engine as derived from the Engine Technical Certificate.

EXAMPLE: A Gipsy Queen 70 Mk. 2 engine is run at a manifold pressure of 42 inHg and at 2700 rpm with an air intake temperature of +5°C. If the barometer reading is 30 inHg and the depression gauge reading is 5 inHg, the observed air intake pressure is 25 inHg. Reading from the chart in Figure 3, the intersection of the vertical line corresponding to 2700 rpm and the curve for +5°C intake temperature gives an absolute intake pressure of 25.5 inHg.

If, for this engine, the acceptance conditions for the performance of overhauled engines when tested with a fan (Leaflet 70-60) state that the corrected supercharger compression ratio (at 15°C) obtained during the Final Test and the corrected rpm obtained during the corresponding power check tests shall satisfy the following expression:

$$\frac{r_2}{r_1} + \left(\frac{N_2}{N_1}\right)^2 \text{ shall not be less than } 1.96$$

where r_1 = supercharger compression ratio of the standard engine at the observed rpm of the test as derived from the Engine Technical Certificate.

r_2 = supercharger compression ratio of the engine being tested, at the observed rpm of the test.

N_1 = acceptance rpm of the fan.

N_2 = corrected rpm obtained from the power check tests for engine being tested.

$$\text{Then } r_1 = \frac{42}{25.5} = 1.647$$

$$r_2 = \frac{42}{25} = 1.68$$

$$N_1 = 2700$$

and assuming $N_2 = 2680$

$$\frac{1.68}{1.647} + \left(\frac{2680}{2700}\right)^2 = 1.02 + 0.985 = \underline{2.005}$$

INTENTIONALLY LEFT BLANK

Leaflet 70-80 Guidance Material for Ageing Engine Continuing Airworthiness

Update: April 2022

The updated version of Leaflet 70-80 has been published as a Supplementary Amendment (SA) to CAP 562.

It can be downloaded from this [list of CAP 562 \(CAAIP\) Supplementary Amendments](#)

Update: April 2022

The updated version of Leaflet 70-80 has been published as a Supplementary Amendment (SA) to CAP 562.

It can be downloaded from this [list of CAP 562 \(CAAIP\) Supplementary Amendments](#)

Update: April 2022

The updated version of Leaflet 70-80 has been published as a Supplementary Amendment (SA) to CAP 562.

It can be downloaded from this [list of CAP 562 \(CAAIP\) Supplementary Amendments](#)

Update: April 2022

The updated version of Leaflet 70-80 has been published as a Supplementary Amendment (SA) to CAP 562.

It can be downloaded from this [list of CAP 562 \(CAAIP\) Supplementary Amendments](#)

Update: April 2022

The updated version of Leaflet 70-80 has been published as a Supplementary Amendment (SA) to CAP 562.

It can be downloaded from this [list of CAP 562 \(CAAIP\) Supplementary Amendments](#)

Update: April 2022

The updated version of Leaflet 70-80 has been published as a Supplementary Amendment (SA) to CAP 562.

It can be downloaded from this [list of CAP 562 \(CAAIP\) Supplementary Amendments](#)

Update: April 2022

The updated version of Leaflet 70-80 has been published as a Supplementary Amendment (SA) to CAP 562.

It can be downloaded from this [list of CAP 562 \(CAAIP\) Supplementary Amendments](#)

Update: April 2022

The updated version of Leaflet 70-80 has been published as a Supplementary Amendment (SA) to CAP 562.

It can be downloaded from this [list of CAP 562 \(CAAIP\) Supplementary Amendments](#)

Leaflet 70-90 **Guidance Material for Power by the Hour Agreements in the Continuing Airworthiness Management Environment**

1 Introduction

- 1.1 This guidance is intended to highlight the considerations necessary for the continuing airworthiness management of airframes, engines, propellers and components in the environment of Power by the Hour (PBH) Agreements. This is particularly relevant to large transport aircraft and rotorcraft which are managed under EASA Part-M Subpart G Continuing Airworthiness Management Organisations (CAMOs) and are operating in Commercial Air Transport (CAT) environments.

2 Background

- 2.1 Traditionally, maintenance, repair and overhaul (MRO) services (particularly in workshops) have been provided by EASA Part-145 approved organisations on a time and material basis. Typically, this involved the ownership of spare parts and components by an operator, leading to control of policy, component history records and retention within a controlled environment.
- 2.2 There has been a growing trend towards power by the hour agreements where spare parts can be owned by the service provider and pooled with other operators of the same equipment. Trade name examples of such agreements provided by engine and airframe Original Equipment Manufacturers (OEMs) include Power by the Hour, Eagle Service Plan, Goldcare and Totalcare. The purpose of this guidance material is to emphasise the obligations the operator and continuing airworthiness management organisations have when sub-contracting to a PBH service provider, to ensure appropriate CAMO oversight of activities within a PBH contract.

3 Applicability

- 3.1 This guidance is intended specifically for the following category of aircraft:
- large transport aeroplanes operating for the purposes of commercial air transport
 - business jets
 - commercially operated rotorcraft.
- 3.2 The above aircraft are typically:
- EASA aircraft types issued with an EASA Certificate of Airworthiness and managed under an EASA Part-M Subpart G Approved Continuing Airworthiness Management Organisation approval (CAMO); or
 - EASA aircraft types issued with a UK national Certificate of Airworthiness and operating for State purposes, such as the Police; and
 - subject to power by the hour contracts for continuing airworthiness management activities.

4 Time and Material Parts Overhaul

- 4.1 Traditionally, components (such as engines, propellers and parts which may have been owned by the operator) are sent to Part-145 MRO organisations to be repaired/overhauled under, “time and material”, agreements, where labour plus the price of spare parts incurred are charged. This is under the control of the operator / CAMO, liaising directly with the MRO to specify the scope of work to be carried out (repair or full strip and overhaul), and the extent to which non-mandatory service bulletins will be embodied (normally referred to as ‘work scoping’).
- 4.2 The typical arrangements between operator, OEM and overhauler are demonstrated in Figure 1 below.

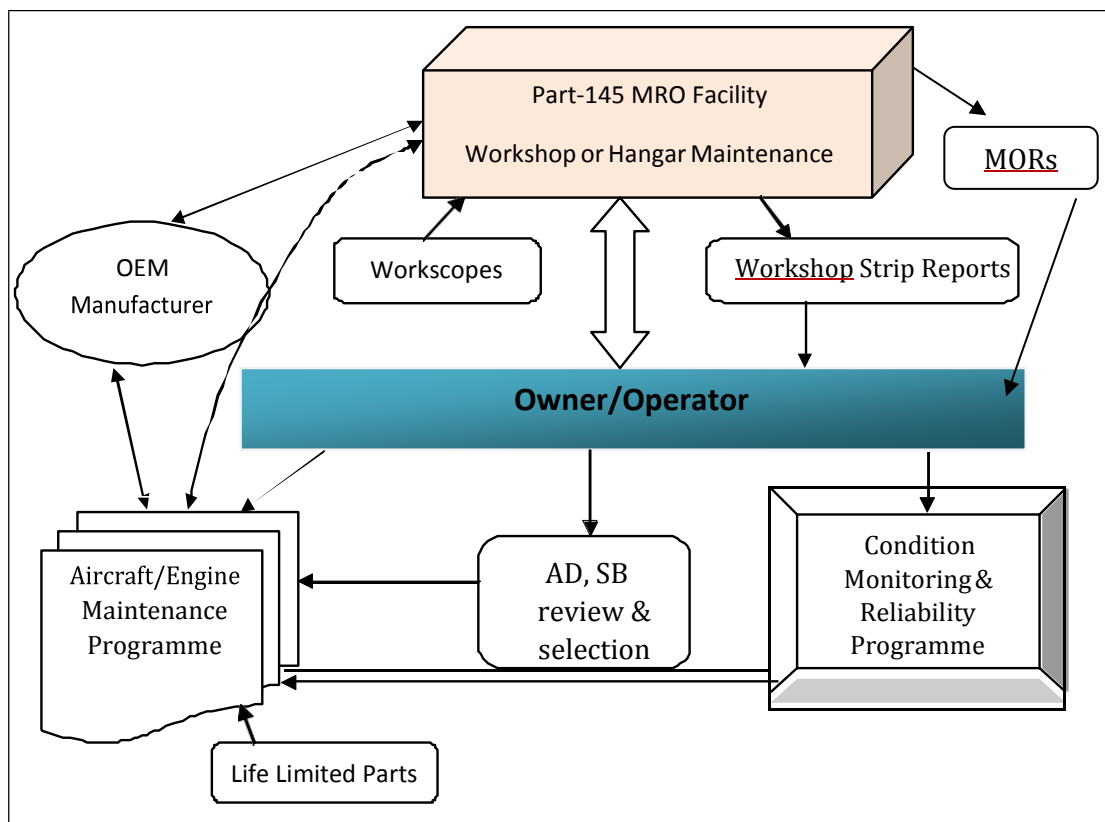

Figure 1 Typical Time and Material Engine/Component Overhaul Agreement Links

5 Power by the Hour (PBH) Agreements

- 5.1 To accommodate maintenance and overhaul costs over a set period, PBH service providers charge operators at a fixed rate by the flight hour or flight cycle for the operational use of components (such as engines, APUs, rotorcraft transmission assemblies, wheels and brakes) or complete airframes. Under this agreement the spare parts may not always be owned by the operator. Furthermore, it is in the interests of both the service provider and the operator for the components and/or airframes to be at their most reliable, to maximise on-wing life and to minimise the number of workshop visits.
- 5.2 Continuing airworthiness conditions of this type of agreement may require routine maintenance tasks such as compressor washes, borescope inspections or fuel nozzle changes to be carried out at regular intervals.
- 5.3 In some circumstances, the OEM can become the PBH service provider and performs several Continuing Airworthiness (CAW) functions or controls the subcontracting of these activities. The relationship between a typical PBH service provider and an aircraft operator is demonstrated in Figure 2, where many of the CAW functions may be directly controlled or managed by the service provider.
- 5.4 In this situation where workshop overhaul and repair services are usually contracted to various third party organisations it is invaluable that workshop strip reports, which provide details on any potential impending wear out failures or failure modes, are made available as feedback to the CAMO. One purpose of strip reports is to assist in determining the effectiveness of the aircraft maintenance programme, take appropriate action and update it where necessary. The feedback provided by the component strip report could have significant implications for the safety of the operator's fleet for the particular aircraft type.
- 5.5 The CAMO should also be made aware of any findings during workshop teardown of a safety significant nature so that a Mandatory Occurrence Report (MOR) can be raised and submitted appropriately.

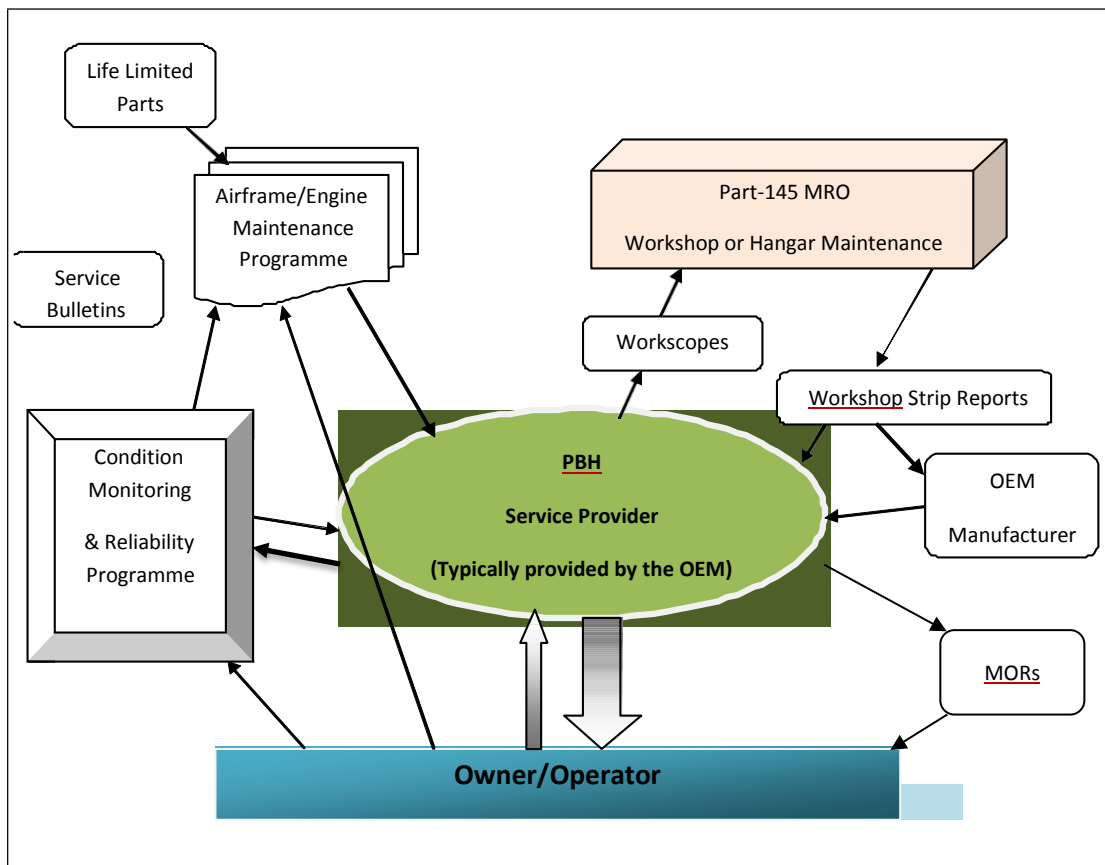

Figure 2 Potential Activity Links Under a Power by the Hour Agreement

6 Power by the Hour Agreement Characteristics

- 6.1 Frequently the PBH service provider may own the spare parts or components, which may influence the status of recommended and optional OEM service bulletins and the rework specifications carried out.
- 6.2 Although the PBH service provider may be contracted to directly carry out various continuing airworthiness activities under an agreement, it is necessary to understand that the ultimate responsibility for an aircraft resides with the aircraft owner / operator. M.A.201(a) Responsibilities, states; "The owner is responsible for the continuing airworthiness of an aircraft and shall ensure that no flight takes place unless:
1. The aircraft is maintained in an airworthy condition, and;
 2. The Airworthiness Certificate remains valid, and;
 3. The maintenance of the aircraft is performed is performed in accordance with the maintenance programme."
- 6.3 To further emphasise this point, AMC M.A.201(e)(2)3 stipulates that, "The operator is ultimately responsible and, therefore, accountable for the airworthiness of its aircraft".
- 6.4 When PBH services are contracted (such as Part-145 Approved MROs) or subcontracted (such as CAW tasks) it is important to ensure that all continuing airworthiness functions carried out under this agreement meet the obligations of Part-M Subpart G CAMO where applicable. A list of potential continuing airworthiness tasks and the associated requirements references are listed in Table 1 below.

Table 1 Potential Activities within a Power By the Hour Agreement

PBH Activities	Part-145	Part-M
MRO workshop	✓ Part-145	✓ M.A.502(b)/(c)
Contracted maintenance	✓ 145.A.75	✓ M.A.708
Health monitoring		✓ <u>AMC</u> <u>M.A.711(a)(3)4(d)</u>
Maintenance programmes		✓ M.A.302
Recommended SB review		✓ M.A.301-7
Reliability data		✓ M.A.302(f)
Individual Workscoping	✓ 145.A.45(b)	✓ <u>Appendix XI</u> to M.A.708(c), 2.23.2
Workshop strip reports		✓ <u>Appendix I</u> to M.A.302 6.5.4.2(e)
Life limited parts control	✓ 145.A.45(b)3	✓ M.A.708(b)8
Parts records <u>system</u>	✓ 145.A.55	✓ M.A.305
Occurrence reporting	✓ 145.A.60	✓ M.A.202
Airworthiness Directives	✓ <u>145.A.45</u>	✓ <u>M.A.303</u>
Unsalvageable parts	✓ 145.A.42(c)	✓ M.A.504(c), <u>M.A.501(a)(3)</u>

7 Scope of Contracted/Sub-contracted PBH Activities

Continuing airworthiness management activities carried out by sub-contractors to the PBH agreement should be referred to in the Continuing Airworthiness Management Exposition (CAME).

8 Quality Systems

- 8.1 The quality system of the CAMO is required to monitor all M.A. Subpart G continuing airworthiness activities which are carried out under the scope of its approval, and which are referred to within its approved procedures. Therefore, in the case of power by the hour agreements where some CAW activities are subcontracted to a service provider, the CAW sub-contracted activities should be included in the CAMO's quality monitoring system.
- 8.2 All contracted maintenance carried out by PBH service provider workshops should also be subject to quality system monitoring by the CAMO. Examples of oversight contracted activities include quality auditing of the Part-145 maintenance repair and overhaul (MRO) facilities and workshops.

9 Approved Aircraft Maintenance Programmes

- 9.1 CAMO responsibilities include the development and control of the Aircraft Maintenance Programme (AMP). This should include the requirements for components fitted to the aircraft including engines, APUs and propellers, on and off-wing scheduled maintenance. An AMP should include reference to the Type Certificate Holder's (TCH's) data such as maintenance planning documents, engine planning documents, manuals, Airworthiness Directives, service bulletins and service letters where applicable.
- 9.2 The programme should reflect the operator's customised policy towards the maintenance of its components, including but not limited to the following:
- Module soft lives;
 - Rework specifications;
 - Policy on the use of PMA parts (if used) and third-party repair;
 - Operational profile selection for the control of service life limited parts (based on TCH input).
- 9.3 EASA Part M.A.301 requires the owner or the CAMO managing the continuing airworthiness of the aircraft to have a system established to be able to effectively assess their maintenance programmes. The use of workshop strip reports is necessary as a means of assessing the performance (and potential deterioration) of components (including complete engines and rotorcraft transmission assemblies) in service, taking into account the individual operational and environmental characteristics of each operator. Strip reports are usually compiled by the Part-145 approved MRO maintenance organisation, following final assembly and test phases. Such reports are utilized for both scheduled and unscheduled component removals and the data fed back to the CAMO responsible (also potentially to the OEM) for proactive review.
- 9.4 Issues arising from continuing airworthiness activities (such as from workshop strip reports) which are of an airworthiness concern and meet occurrence reporting criteria, must be raised and submitted as an MOR for review and proactive action as necessary, in a timely manner, to prevent reoccurrence. The respective OEM's design organisation should also be actively included in such data feedback for their inclusion in the review process.

10 Engine/APU Power By the Hour Issues

- 10.1 Under a PBH agreement certain continuing airworthiness tasks may be carried out by the service provider whilst the engine is on-wing and in operational service. In these cases, it is important to have in the agreement and available at a working level, established procedures verifying clear lines of responsibility between stakeholders and how they should function.
- 10.2 Examples of sub-contracted activities could include (but not be limited to) the control of service life limited parts (such as engine discs and shafts, and rotorcraft transmissions), the tracking of engine deterioration within approved limits and health monitoring. The monitoring of any deterioration such as on blades, vanes and combustion liners must be within limits specified in approved data such as OEM's engine manuals, or alternative EASA design approved data sources.
- 10.3 Prior to engines or modules entering the workshop for repair or overhaul, the CAMO should engage in the engine workscoping process to define the extent of scheduled work and inspections to be carried out, based on module soft lives, rework

specifications and policies set in the maintenance programme. Workscoping will also define the requirement to embody any additional work items such as ADs, SBs and modifications to determine an engine on-wing life expectancy.

11 Power By the Hour Compliance with EASA Part-M

- 11.1 All contracted maintenance and sub-contracted continuing airworthiness management agreements as required through a typical PBH contract should be reviewed against the EASA Part-M requirements and the associated AMC. A contract with an PBH service provider should make reference to the maintenance provider, their location and the applicable Part-145 approval reference. Refer to Part M, M.A.708(c).
- 11.2 Details contained with the typical PBH contract should include the scope of the contract services provided, continuing airworthiness tasks, and the various communication links. Reference to any regular reviews such as workscope, reliability, quality, technical and management review meetings should also be considered for inclusion, stating the necessary participants and frequency.
- 11.3 As part of its regulatory oversight responsibilities, the Competent Authority (such as the CAA) will expect to attend a sample number of co-ordination meetings between CAMO and PBH service provider to establish the effectiveness of working procedures, communications (such as via meetings), data and statistics, and records, as well as understanding the limits of delegation in this process.
- 11.4 Key to understanding the relationship between CAMO and PBH service provider is that the owner/operator/CAMO cannot absolve their ultimate responsibility under Part-M.A.201 for the airworthiness of an aircraft. The implication of this is that the CAMO must retain control and actively participate in various processes such as the component workscope decision making process. When components are received from a pool of parts shared with other operators, it is important to understand that the CAMO has responsibility for controlling the configuration and modification standard of any component they receive, rather than just accepting a standard that they are given.

INTENTIONALLY LEFT BLANK

Appendix 1 Owner/Operator Checklist Considerations in a Power By The Hour Environment

<u>PBH</u> activities	EASA References and Details	Means of Compliance
Occurrence Reporting	<u>Part M Subpart B</u>	
Mandatory Occurrence Reporting	M.A.202	Contracted <u>PBH</u> MRO shall report to the competent authority and also to the owner a condition affecting the operator's aircraft or component.
Continuing Airworthiness	<u>Part M Subpart C</u>	
Non-Mandatory SB embodiment policy	AMC M.A.301-7	A policy to assess non-mandatory airworthiness information (SBs and SLs etc.) relating to the aircraft and its components.
Maintenance Programmes	M.A.302	Customised aircraft maintenance programme for each, inclusive of; Component and Parts workshop maintenance
Reliability Programme Data	M.A.302(f); Appendix 1 to AMC 302 6.5.4.2(e)	Use of component (such as engine/ APU) workshop strip reports to update reliability programme.
Airworthiness Directives	M.A.303	<u>Ensuring timely compliance</u> with applicable ADs
Repairs and Modification Data	M.A.304	Repairs and modifications carried out using suitably approved data e.g. by EASA or Part-21J design organisation.
Aircraft and Component Continuing Airworthiness Record System	M.A.305	EASA Form 1 release, status of life limited parts, mods, repairs, ADs, SBs log books, maintenance work packs Records to include those for pooled parts installed.

PBH activities	EASA References and Details	Means of Compliance
Components	<u>Part M Subpart E</u>	
Installation of Components	M.A.501	Appropriate release documentation – EASA Form 1 or equivalent and satisfactory condition of components. All/any PMA parts used must be appropriately design approved e.g. Critical parts to have EASA approved STCs
Component Maintenance	M.A.502	The repair maintenance and overhaul of components shall be carried out by appropriately approved MRO organisations.
Unsalvageable Parts	M.A.504(c); 145.A.42(c); <u>M.A.501(a)(3); AMC</u> <u>M.A.501(a)(3)</u>	Unsalvageable parts or those which have exceeded service life limits must be mutilated and disposed of in accordance with an approved CAMO procedure.
Continuing Airworthiness Management Organisation	<u>Part M Subpart G</u>	
Continuing Airworthiness Management	M.A.708(b)	Coordination of scheduled maintenance
		Customised aircraft maintenance programme
		Control of service life limited parts.
		Manage approval of mods and repairs.
		Policy and control of ADs mods and SBs
Contracted Maintenance Service Provider	M.A.708(c)	Written contract between operator and contracted PBH <u>service provider</u> , Part-145 MRO, with approval reference

PBH activities	EASA References and Details	Means of Compliance
<u>CAMO responsibilities for Continuing Airworthiness Management</u>	<u>M.A.711(a)(3)</u>	<u>Management of Airworthiness Directives</u>
		<u>Planning of Maintenance</u>
		<u>Reliability Monitoring</u>
		<u>Engine Health Monitoring</u>
		<u>Maintenance Programme Development.</u>
		<u>Limited sub contracted CAM tasks.</u>
<u>Service Bulletins</u>		
<u>Subcontracting of Continuing Airworthiness Management tasks</u>	<u>AMC M.A.711(a)(3)</u>	<u>PBH CAM subcontractors listed in Continuing Airworthiness Management Exposition, and contracts reviewed as acceptable by competent authority.</u>
<u>Significant sub-contracted Responsibilities listed on Form 14 approval certificate</u>	<u>AMC M.A.711(a)(3)</u>	<u>The operator should only sub contract to PBH organisations as specified on the AOC or EASA Form 14 as applicable.</u>
Quality System Monitoring of Contracted and Subcontracted Activities	M.A.712(b)	Adherence to Quality Monitoring audit plan
PBH and Maintenance Contracts	Appendix XI to AMC M.A.708(c)	
Contract Applicability	Appendix XI to AMC M.A.708(c)	Applicable to aircraft, engine and APU contracted maintenance as appropriate.
Contract Locations	-----"-----	Aircraft base, line maintenance locations as well as engine and APU workshop locations – to include Part-145 Approval references.
Subcontracted activities under contract	-----"-----	Details subcontracted tasks under the agreement.
Contracted Maintenance performed in accordance with Maintenance Programme	-----"-----	The aircraft maintenance programme including engine/APU maintenance programmes should be specified.

PBH activities	EASA References and Details	Means of Compliance
Continuing Airworthiness Activities in Maintenance Agreement	-----“-----	Management <u>and inclusion of</u> service life limited components, ADs, SBs, mods and repairs, hours & cycles control, defect rectification, deferred tasks etc.
Contracted Maintenance Release to Service Documentation	-----“-----	Release documentation including notification of SB, AD, mod and repair status and embodiment etc.
Contracted Maintenance Records	-----“-----	Access to and storage of records of maintenance carried out under the maintenance agreement.
Meetings with contracted service provider	-----“-----	Meetings with the service provider should consider the following agendas; contract review, work scope planning, strategic technical, quality and reliability.

Chapter 100 Computer Hardware-Software

Leaflet 100-10 Aircraft Field Loadable Software (FLS) and Database Field Loadable Data (DFLD)

1 Introduction

- 1.1 The CAA has become aware of a number of occasions where a lack of adequate control of FLS and DFLD by operators has given rise to safety related occurrences.
- 1.2 The purpose of this Leaflet is to provide guidance for operators and maintenance organisations on the configuration management, procurement, embodiment and tracking of aircraft FLS and DFLD to ensure that continued airworthiness and operating safety standards are met.
- 1.3 The content of this Leaflet is based upon established as well as developing international standards.
- 1.4 It is recognised that operators and maintenance organisations may have already implemented satisfactory alternatives that meet the intent of this Leaflet. It will not be necessary for those organisations to change these procedures if they already meet the intent of this Leaflet.
- 1.5 The content of this Leaflet should be used to supplement the content of the Type Certificate (TC) or Supplemental Type Certificate (STC) holder's instructions.
- 1.6 This Leaflet is technology focussed and the content should be considered as applicable to any aircraft using this level of technology.
- 1.7 This Leaflet does not apply to software applications for Electronic Flight Bags. For guidance on this subject the reader should refer to JAA Administrative and Guidance Material, Section Four: Operations, Part Three: Temporary Guidance Leaflets (JAR-OPS): Leaflet No. 36: Approval Of Electronic Flight Bags (EFBs)

2 Definitions

- 2.1 For the purpose of this Leaflet the following definitions apply:
 - a) **Aircraft Configuration List (ACL):** A list of Line Replaceable Units (LRU) and modules with Loadable Software Aircraft Parts (LSAPs) that are applicable to a specific aircraft. This list may be contained on data supplied by the Type Certificate (TC) Holder in a Service Bulletin (SB), Service Information Letter (SIL) or Illustrated Parts Catalogue (IPC), or as a separate tracking system.
 - b) **Field Loadable Software (FLS):** Software (executable code) that can be loaded without removing the system or equipment from the aircraft. FLS can be loaded onto an aircraft system by a maintenance mechanic/technician in accordance with defined maintenance manual procedures. FLS can be configured as a component of target hardware and thus affect the part number of the target hardware. There are numerous types of FLS, but most can be categorised as follows:
 - i) **Loadable Software Aircraft Part (LSAP):** FLS that is required to meet a specific airworthiness or operational requirement or regulation and not considered as a component of the target hardware, but is considered to be part

of the aircraft approved design and therefore an aircraft part requiring formal controlled release documentation (EASA Form 1 or FAA 8130-3).

- ii) **User Modifiable Software (UMS):** Software declared by the aircraft Type Certificate holder's design organisation (or Supplementary Type Certificate holder's design organisation) as being intended for modification by the aircraft operator.
 - iii) **Option Selectable Software (OSS):** LSAP that contains approved and validated components and combinations of components that may be activated or modified by the aircraft operator within defined TC/STC Holder boundaries.
- c) **Database Field Loadable Data (DFLD):** Data that is field loadable into target hardware databases.
- i) **Database:** A term generally misused to describe the "data" that is field loaded into target hardware. However, the database is actually an embedded item that resides within the target hardware and is not, itself, field loadable. The process normally described as "loading a database" actually loads a data file onto the target hardware's embedded database. The updating of the data held on a database, by the uploading of a new data file, will normally be conducted to provide for modifications to operating functions, including the revision of the aircraft performance or navigational data. It should be noted that whilst "LSAP" is only associated with FLS (executable code), certain DFLD should be treated in the same manner, in that they will have their own part number requiring control as an aircraft part and should be accompanied by controlled release documentation (EASA Form 1 or FAA 8130-3). The form of release required for different types of DFLD is defined in paragraph 3.
 - ii) **Data File:** A specific file that contains the actual data that is the object of the database and is field loaded.
- d) **Target Hardware:** The hardware such as Line Replaceable Units (LRU) and modules that are intended to be loaded with FLS or DFLD.
- i) Examples of target hardware for LSAP (FLS) could be: an Electronic Engine Control (EEC), a Digital Flight Data Acquisition Unit (DFDAU), an Auxiliary Power Unit's Electronic Control Unit (ECU), a Flight Guidance Computer (FGC), or an Integrated Modular Avionics (IMA) Unit.
 - ii) Examples of target hardware with databases that could be field loaded with DFLD that need to be tracked in the same manner as an aircraft part, could include: a Flight Management Computer (FMC), a Terrain Awareness Warning System (TAWS) Computer, or an IMA Unit.
 - iii) Examples of target hardware for UMS could be: Aircraft Condition Monitoring System (ACMS) and In-Flight Entertainment System (IFE).
 - iv) Examples of target hardware for OSS could be an IMA Unit.
- e) **Media Distribution of FLS or Data files:** A process whereby FLS or Data files are moved from the production organisation or supplier to a remote site (generally the operator) using storage media.
- f) **Storage Media:** Device that contains a copy of the FLS or Data files such as a diskette, Personal Computer Memory Card International Association (PCMCIA) card, Compact Disc Read Only Memory (CD ROM), Onboard Replaceable Modules (OBRM), file servers or portable data loaders.

- g) **Electronic Distribution of FLS or Data files:** A process whereby FLS or DFLD are moved from the producer or supplier to a remote site (generally the operator) without the use of FLS storage media.

3 Release of FLS and DFLD

3.1 Methods of Release

The release of FLS and DFLD is dependent upon whether it is required to meet a specific airworthiness or operational requirement, or certification specification.

3.2 Release of Non-Required FLS or DFLD

For FLS or DFLD that is not required to meet a specific airworthiness or operational requirement or regulation, or certification specification, a Certificate of Conformity should be sufficient.

3.3 Release of Required FLS or DFLD

Where the FLS or DFLD is required to perform a function to meet a specific airworthiness or operational requirement or regulation, or certification specification, the following should be taken into account.

3.3.1 LSAP

An EASA Form 1 or FAA 8130-3 should accompany any FLS (executable code) that is required to meet a specific airworthiness or operational requirement or regulation, or certification specification, i.e. LSAP. Examples of LSAP that would require such release could be FLS that is associated with any of the examples of target hardware in paragraph 2(d)(i) above.

3.3.2 DFLD

An EASA Form 1 or FAA 8130-3 should accompany any DFLD (data file) that is required to meet a specific airworthiness or operational requirement or regulation, or certification specification. Examples of DFLD that require such release could be those associated with IMA, as mentioned in paragraph 2(d)(ii) above.

3.3.3 Navigational Data

A “Letter of Acceptance” (LOA) as defined on EASA’s website, or equivalent, should accompany the release of any navigationable database’s DFLD, where approvals are required (e.g. Precision RNAV), because an EASA Form 1 or FAA 8130-3 cannot be provided.

a) Type 1 LOA

A Letter of Acceptance granted where a Navigation Database supplier complies with EUROCAE ED-76 / RTCA DO-200A documents with no identified compatibility with an aircraft system. A Type 1 LOA holder confirms that the processes for producing navigation data comply with these Conditions and the documented Data Quality Requirements. A Type 1 LOA holder may not release navigation databases directly to end-users.

b) Type 2 LOA

A Letter of Acceptance granted where a Navigation Database supplier complies with EUROCAE ED-76 / RTCA DO-200A documents and provides data compatible with specified avionics system(s). A Type 2 LOA holder confirms that the processes for producing navigation data comply with these Conditions and the documented Data Quality Requirements for the avionics systems specified. The

Data Quality Requirements must be provided by or agreed with the specified equipment design organisation in accordance with a formal arrangement. A Type 2 LOA holder may release navigation databases directly to end-users. Such releases may also include data packing tools, where the use of such tools has been demonstrated to be ED-76/DO-200A compliant. A Type 2 LOA holder may interface directly with data originators (such as State AIP providers and operators), or may use data supplied by a Type 1 LOA holder in which case interface with data originators may not be necessary.

3.4 **Release Equivalency**

It should be noted that Certificates of Conformance are not considered to be equivalent to either an EASA Form 1 or FAA 8130-3.

3.5 **Electronic Distribution Release**

The Electronic Distribution of FLS or Data files should recognise this requirement and provide an equivalent means of formally controlled release. This will need to be agreed by the CAA.

4 **Procurement and Documentation of FLS and DFLD**

4.1 **FLS and DFLD**

FLS and DFLD are normally delivered with the new aircraft and contained in the Target Hardware and in media sets in binders or storage bins, noting that the part number of the Target Hardware may not necessarily indicate the loaded software part number. (See Appendix 1 Paragraph 1.4 b)).

4.2 **LSAP**

Procured LSAP must be obtained from an approved source, using the part number specified and accompanied by an EASA Form 1 or an equivalent acceptable to the CAA. The part number can typically be confirmed as approved by reference to documents such as the IPC, SB and SIL, or to an appropriately approved modification (TC/ATC/STC).

4.3 **DFLD**

Data Field Loadable Data files used for the update of databases such as Navigational Databases, Terrain Databases and Model/Engine Databases should be acquired from a source that is acceptable to the Target Hardware Manufacturer, and accompanying documentation and DFLD Storage Media containing the data file should clearly identify this. The DFLD storage media should also be annotated with the originator identification and quality/conformity markings. The Electronic Distribution of DFLD should recognise these points and provide an equivalent level of control agreed by the CAA. The responsibility of obtaining appropriate confirmation of the authenticity, performance specification and accuracy of the DFLD rests with the operator. It is also recommended that a "confidence" check of the received data be accomplished to ensure that the new data satisfies the intended use. The DFLD should be subjected to a configuration control process acceptable to the CAA (see Appendix 1 paragraph 1).

4.4 **UMS**

UMS is FLS that is normally modified by the operator, their contracted maintenance organisation or approved vendor using the appropriate methods identified during initial certification. The responsibility for obtaining adequate documentation confirming the appropriateness of the software rests with the operator. If an instance occurs, when a change to target hardware's software that has been defined as UMS

actually modifies aircraft performance information presented to the flight crew, CAA advice should be sought as approval may be required and the software classification of UMS may be removed.

4.5 **Distribution of FLS and DFLD**

FLS and Data Files can be distributed to the aircraft operator using a variety of methods, which include use of software media (such as diskettes), CD ROMs, PCMCIA Cards or electronically, such as via the Internet. The operator is responsible for establishing a process to ensure that the FLS or data file received is the FLS or data file approved and that the FLS or data file has not been corrupted (e.g. making use of a Cyclic Redundancy Check (CRC)). Complying with the aircraft manufacturers recommendations and utilising the recommended tooling could achieve this.

4.5.1 **Media Distribution of FLS or DFLD**

If the FLS or DFLD is to be supplied using diskettes, CD ROMs or PCMCIA cards the following should be considered:

- a) The FLS or DFLD should be virus checked upon receipt and stored in a controlled location if not being immediately loaded onto an aircraft system. (This requirement assumes that the media store has appropriate protections and controls to prevent unauthorised access to the media. If this is in any doubt, the FLS or DFLD should be virus checked immediately prior to loading it onto an aircraft system.) The target hardware manufacturer should provide guidance on how this virus checking should be accomplished.
- b) The method of transportation should be appropriate to ensure that it does not result in damage or corruption of the storage media or FLS or DFLD. If this is in any doubt, the FLS or DFLD should not be loaded onto an aircraft system.
- c) The FLS or DFLD should be accompanied by the appropriate release paperwork, as stated in paragraph 3.

4.5.2 **Electronic Distribution of FLS or DFLD**

EDS is increasingly being utilised to transfer FLS or DFLD from the supplier to an operator. The obvious advantages of this are the speed of distribution and the removal of the need for physical transport media. This should be accomplished to an acceptable standard (see Appendix 1 paragraph 1). Such an acceptable standard would normally be that of meeting the intent of the guidance in this Leaflet. If the FLS or DFLD is supplied over the Internet this should be accomplished in accordance with a procedure detailed in Appendix 1, paragraph 1.3.

5 **FLS and DFLD Storage Media Handling**

The operator is responsible for ensuring the suitability of any storage media used. In order to ensure FLS and DFLD integrity, the storage media should be kept and processed in an environment that is not detrimental to that storage media, noting any limitations associated with that media. Additional information may be found in Appendix 1.

6 **FLS and DFLD Loading and Certification**

6.1 **Prior to loading**

Prior to loading FLS or DFLD onto the aircraft the operator should consider the points in Appendix 1.

6.2 Loading FLS or DFLD

Loading FLS or DFLD onto aircraft target hardware should be carried out and verified in accordance with the established processes and procedures detailed in the maintenance manual or associated approved maintenance or modification data.

6.3 Recording aircraft FLS and DFLD configuration

All FLS and DFLD loading should be recorded in the Aircraft Configuration List (ACL), and a copy kept on board the aircraft with a further copy also kept in the operators' aircraft maintenance records system.

6.4 Aircraft Release to Service

After any loading of FLS or DFLD a Certificate of Release to Service must be issued by an appropriately authorised/licensed person.

7 Replication of FLS and DFLD

7.1 FLS or DFLD copies

If FLS or DFLD copies are to be made by the aircraft operator for use within their organisation, this should be accomplished using the aircraft type design organisation approved FLS and DFLD Storage Media replication process. This replication should be recorded in an Aircraft FLS/DFLD Replication Register and be traceable to the original source from which copies were made. This is to ensure that this activity could be audited.

7.2 Release documentation

A copy of the original JAA Form One, EASA Form 1, FAA 8130-3, Letter of Acceptance (for navigation databases) or other CAA accepted release documentation, as defined in paragraph 3, should accompany the FLS or DFLD Storage Media containing copies of the FLS or DFLD (Part 21.A.307 and Part 145.A.42 refer).

8 Procedure

8.1 Configuration Control

It is essential that operators consider use of appropriate procedures such that at any time they can determine the equipment, FLS and DFLD configuration of each aircraft in their fleet.

8.2 Use of notice recommendations

Operators involved in the procurement, modification and embodiment of FLS and DFLD should consider producing a documented procedure within their Company Procedures, Maintenance Management Exposition (MME) or equivalent that describes their means of implementing procedures recommended by this Leaflet. Further guidance can be found within Appendix 1 to this Leaflet. It is expected that any procedure would cover the complete cycle from procurement specification; distribution methodology (e.g. Electronic Distribution, media type etc.); receipt inspection and assessment through to embodiment; subsequent testing and release to service. This process should also be considered for inclusion in the operator's internal audit programme.

8.3 Staff

Operators should ensure that sufficient numbers of competent staff are retained in order to ensure that the intent of guidance within this Leaflet is met.

9 Recommended Reference Material

USA	Europe	Description
RTCA DO 178B	EUROCAE Doc. ED 12B	Software Considerations in Airborne Systems and Equipment Certification
RTCA DO 200A	EUROCAE Doc. ED 76	Standards for Processing Aeronautical Information
	JAA TGL 36	JAA Administrative and Guidance Material, Section Four: Operations, Part Three: Temporary Guidance Leaflets (JAR-OPS): Leaflet No. 36: Approval Of Electronic Flight Bags (EFBs)

NOTE: Or any later versions of the above documents.

9.1 Documents referenced in this Leaflet can be obtained from:

EUROCAE, 102 rue Etienne Dolet, 92240-Malakoff, France.

Fax No. +33 (0)140927930

Web site: www.eurocae.org

RTCA Inc. 1828 L Street NW, Suite 805, Washington DC. 20036 USA. Web site: www.rtca.org

INTENTIONALLY LEFT BLANK

Appendix 1 FLS and DFLD Control, Tooling and Loading

1 Procedures for the control of FLS and DFLD

The operator should consider providing the following for the control of FLS and DFLD

1.1 FLS and DFLD Register

A controlled FLS and DFLD register, which includes the following:

- a) The version of the FLS and DFLD owned;
- b) Which aircraft the FLS and DFLD are installed on;
- c) The aircraft, systems and equipment that they are only applicable to;
- d) The functions that the recorded FLS or DFLD performs;
- e) Where it is stored (on or off aircraft location, including the storage media) and who has access to it;
- f) Who can decide whether an upgrade is needed and then authorise that upgrade; and
- g) A record of all replicated FLS/DFLD, traceable to the original source.

1.2 Storage Facility

An appropriate storage facility for the FLS and DFLD. While selecting an appropriate location, the following should be taken in to account:

- a) Access to the location should be appropriately controlled.
- b) The environmental conditions within the location should be appropriate for the storage of the FLS and DFLD media and provide protection against all forms of environmental contamination, including water, fire, heat and electrical or magnetic fields.
- c) If the main source of the FLS and DFLD are an electronic store (e.g. a central database of software programs) that store should be:
 - i) subject to configuration control processes;

NOTE: ED-12B/DO-178B provides criteria for such a process by defining the configuration control process's objectives as:

 - Configuration items are identified.
 - Baselines and traceability are established.
 - Problem reporting, change control, change review, and configuration status accounting are established.
 - Archive, retrieval, and release are established.
 - Software load control is established.
 - Software life cycle environment control is established.
 - ii) appropriately isolated from the rest of the network to prevent unauthorised access or contamination from viruses. This isolation can be achieved using a series of access control functions and firewalls. However, protecting a networked system against viruses is a complex issue and consideration should be given to this store being separated from the network.

- d) An appropriate number of backups should be maintained utilising standard software backup techniques.

1.3 **FLS and DFLD Receipt Procedures**

Specific procedures implemented for the receipt of FLS and DFLD that are transferred using electronic distribution techniques should give consideration to the following:

- a) That the FLS or DFLD has come from an appropriate source and that sufficient configuration control processes are in place to ensure that the correct data and/or executable code will be supplied.
- b) That they are accompanied by suitable release documentation.
- c) That a record of purchase is created.
- d) That suitable controls are in place to prevent use of FLS and DFLD that have become corrupted during its existence in any “open” environment, such as on the Internet.
- e) That means are provided to allow detection of corruption.
- f) That connecting a central electronic store for FLS and DFLD storage directly to the Internet is avoided wherever possible.

However, where this cannot be avoided, or if the FLS or DFLD are ported straight from the Internet to a central electronic store, a means to detect interference or corruption are provided.

1.4 **FLS and DFLD Loading Procedures**

Specific procedures implemented for the loading of FLS and DFLD, to target hardware, should consider the following:

- a) The criteria identified within the FLS and DFLD control register, defined in paragraph 1.1 above.
- b) The appropriate authority to embody FLS onto the aircraft (e.g. Aircraft Manufacturer’s Service Bulletin) has been issued and received, i.e. Aircraft Manufacturer’s SB or an STC.

NOTE: A vendor SB does not provide the authority to embody a different part number onto the aircraft.

- c) The need for appropriate verification and recording of target hardware and FLS and certain DFLD part number changes:
 - i) For airborne equipment having separate part numbers for hardware and FLS/DFLD the FLS/DFLD part numbers need not be displayed on the outside of the unit, as long as it can be verified through some kind of electronic query. When new FLS/DFLD is loaded into the unit, the same requirement applies and the approved FLS/DFLD part number should be verified before the unit is released for service. It should be noted, that in circumstances where only the top-level FLS/DFLD part number is displayed for an entire FLS/DFLD load, that affects several items of target hardware – such as might be found in IMA applications – the verification of this number would be necessary.
 - ii) It is the aircraft operator’s responsibility to ensure that the maintenance organisation has entered the FLS/DFLD identification in the aircraft maintenance records such that they can update the aircraft configuration information, such as an ACL.

- iii) If airborne equipment has only one part number, which represents a specific configuration of software and hardware, the unit identification on the nameplate should be changed if new software is loaded. In order for this to be embodied on the aircraft this should be accomplished in accordance with an Aircraft Manufacturer's Service Bulletin. The software part number stored in the target computer after data loading should be verified electronically and confirmed to be an approved configuration as detailed in the SB.
- d) Verification that the upgrade actually is needed.
 - i) If the system is working as required and the FLS or DFLD upgrade is not introducing a required solution or function addition or change, it is not always necessary to upgrade the FLS or DFLD simply for the sake of upgrading. Equally, it is possible that the upgrade could introduce problems that did not exist before.
 - ii) It is also necessary to check any support agreements to ensure that customer support for the FLS or DFLD will remain valid.
- e) Identify what has changed between the different versions of the FLS or DFLD. This should include identifying and recording within the FLS and DFLD register the problems that have been fixed and what functionality has been added or removed. (See paragraph 1.1 d) of this appendix.)

2 Control of FLS or DFLD Tooling

- 2.1 FLS or DFLD can be loaded into the Target Hardware using a variety of tools as recommended and/or approved by the aircraft or target hardware manufacturer. These can include OEM supplied tools, Commercial Off The Shelf (COTS) tools or in-house developed tools.

There are a number of issues associated with FLS or DFLD tooling that the aircraft operator would need to take into account if an alternative to the tooling recommended by the aircraft or target hardware manufacturer was to be considered. Prior to seeking the aircraft or target hardware manufacturer's approval for any alternative tools' use, the aircraft operator should take the following items into account. These are associated with the general tool selection, and the control and the suitability of those tools.

2.2 General Tool Selection

The following general issues should be considered when making a FLS or DFLD tool selection:

- a) What function is the tool required to perform:
 - i) Is it simply loading, leaving other tools or processes to perform compatibility checks and validation tasks?
 - ii) Is it loading and validating the final load, leaving initial compatibility checks to other tools or processes?
 - iii) Is it providing all the tasks associated with loading (compatibility checks, loading and validation) and providing a diagnostic feature?
 - iv) Any other combination of the above should be considered.
- b) Is the tool (which could be a laptop) able to be suitably controlled?
- c) Does the tool supplier have any previous experience in developing tools for the required purpose?

- d) Will the tool supplier provide support and training?
- e) Does the tool provide all the needed functionality or will additional tools or processes be needed?
- f) Does the tool provide the necessary confirmation of what has been loaded on to the aircraft?
- g) Do any existing tools that have CAA acceptance already provide the required functionality?
- h) How much dependence will be placed on the tool?
- i) Will the tool supplier provide support for the tool for the duration of its use?
- j) Is the tool widely used in the industry and does it have a good reputation?
- k) If the tool isn't widely used in the industry, is there any other way to establish its integrity?
- l) Will special training be required to use the tool?
- m) Are there any human factors issues associated with its use?

2.3 **Specific Tool Selection – Original Equipment Manufacturer (OEM) and Commercial Off The Shelf (COTS)**

The issues detailed above apply to the selection of any tool, regardless of who supplies it. The issues detailed below are specific, additional, considerations that need to be considered for OEM and COTS Tools of software tools. If a tool is going to be supplied by the aircraft Type Certificate holder (STC holder) or the equipment manufacturer, or where COTS tooling is going to be supplied (COTS tools are considered to be those which were not supplied by the aircraft Type Certificate holder (or STC holder) or the equipment manufacturer, or developed by the airline/maintenance organisation) the following additional issues need to be considered:

- a) Does the aircraft or target hardware manufacturer recommend it?
- b) Is the tool needed for the FLS or DFLD and aircraft in question?
- c) Was the tool actually developed for use with the FLS or DFLD and aircraft in question?
- d) If the tool was not specifically developed with the FLS or DFLD and aircraft in question, is it compatible with them?
- e) Is the tool likely to be compatible with the whole fleet?

2.4 **Specific Tool Selection – In-house developed tools**

If an aircraft operator is considering developing their own tools the following additional issues need to be considered:

- a) The tool must be developed such that it cannot corrupt the functionality of the aircraft systems it is being used for.
- b) The aircraft operator or their organisation must have a sufficient understanding of the internal aircraft system functionality to be sure of creating a tool that will work correctly.
- c) The aircraft operator or their organisation must have personnel that are experienced in writing tools for aircraft maintenance functions and the associated human factors issues.
- d) The tool should be developed in a suitably controlled fashion.

- e) The operator should gain acceptance for the use of the tool from the aircraft or target hardware manufacturer.

2.5 **Control and suitability of Tools**

If tools are to be used by the aircraft operator, specific processes should be introduced to control their use. These processes should ensure that:

- a) The control of tools including Portable Electronic Devices, such as laptop PCs should prevent the accidental or malicious transfer of viruses.
- b) Portable Electronic Devices should be equipped with up-to-date virus protection software or virus scanned immediately before they are used to load FLS or DFLD on to an aircraft system's target hardware.
- c) The ability of the tool to actually run the software that enables loading should be considered.
- d) Access to the tools should be controlled and recorded.

INTENTIONALLY LEFT BLANK