



Part-NCC Workshop

22 September 2015

Who is affected by NCC?

- Non-commercial operators flying a Complex Motor-Powered Aircraft
- Applicable to operators established, residing or having their principal place of business within the Community
- Applicable regardless of aircraft State of Registry
- Rules already in place but applicable from 25 August 2016

The European Union Aviation Safety System



European Aviation Regulations

Rule hierarchy and responsible organisations



Essential Requirements (ER)

- Legally binding requirements adopted by the European Council and Parliament
- Annexed to the Basic Regulation 216/2008

Implementing Rules (IR)

- Legally binding requirements adopted by the European Commission
- Deviations from Implementing Rules are only possible through the flexibility provisions described in Article 14 of the Basic Regulation 216/2008

CS, AMC, GM – EASA Responsibility

Certification Specifications (CS)

- Technical standards to be used in the certification / approval process
- “Building blocks” for the certification basis
- e.g. CS-FTL, CS-FSTD, CS-AWO

Acceptable Means of Compliance (AMC)

- Technical / procedural material
- One means to comply with the rule – but not the only one
- Presumption of compliance with IR

Guidance Material (GM)

- Interpretative / explanatory material
- Provides guidance on how the rules should be understood

Examples for ER, IR, AMC, GM

- **ER (Annex IV of BR) 2.a.2.**

... Sufficient related information regarding emergency procedures and use of cabin safety equipment must be made available to crew and passengers using specified information....

- **NCC.OP.165 Passenger seating**

The operator shall establish procedures to ensure that:

(a) passengers are seated where, in the event that an emergency evacuation is required, they are able to assist and not hinder evacuation of the aircraft; ...

- **AMC1 NCC.OP.165 Carriage of passengers**

SEATS that PERMIT DIRECT ACCESS TO EMERGENCY EXITS

Passengers who occupy seats that permit direct access to emergency exits should appear to be reasonably fit, strong and able to assist the rapid evacuation of the aircraft in an emergency after an appropriate briefing by the crew

- **GM1 CAT.OP.MPA.165 Passenger seating**

‘Direct access’ means a seat from which a passenger can proceed directly to the exit without entering an aisle or passing around an obstruction.

Flexibility Provisions

These provisions are only available to Member States and applied through the competent authority (CAA in the UK)

- **Article 14 of the Basic Regulation**

- 14 (1) - Reaction to a safety problem
- 14 (4) - Exemption for unforeseen urgent operational needs or operational needs of a limited duration
- 14 (6) - Derogation where an equivalent level of protection to that in the rule can be achieved by other means

European Aviation Regulations

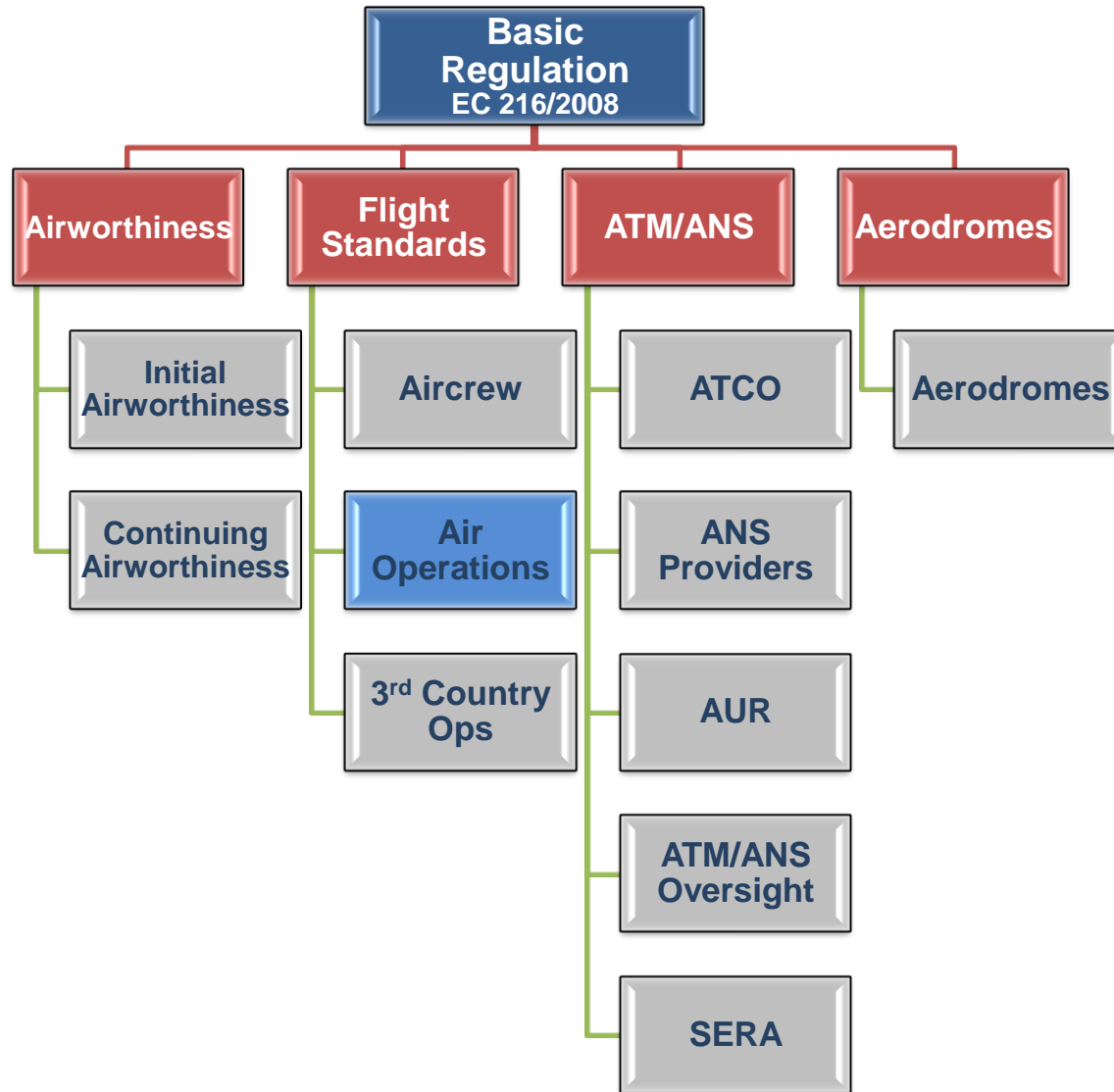

Regulation 965/2012 Air Operations Rule Structure

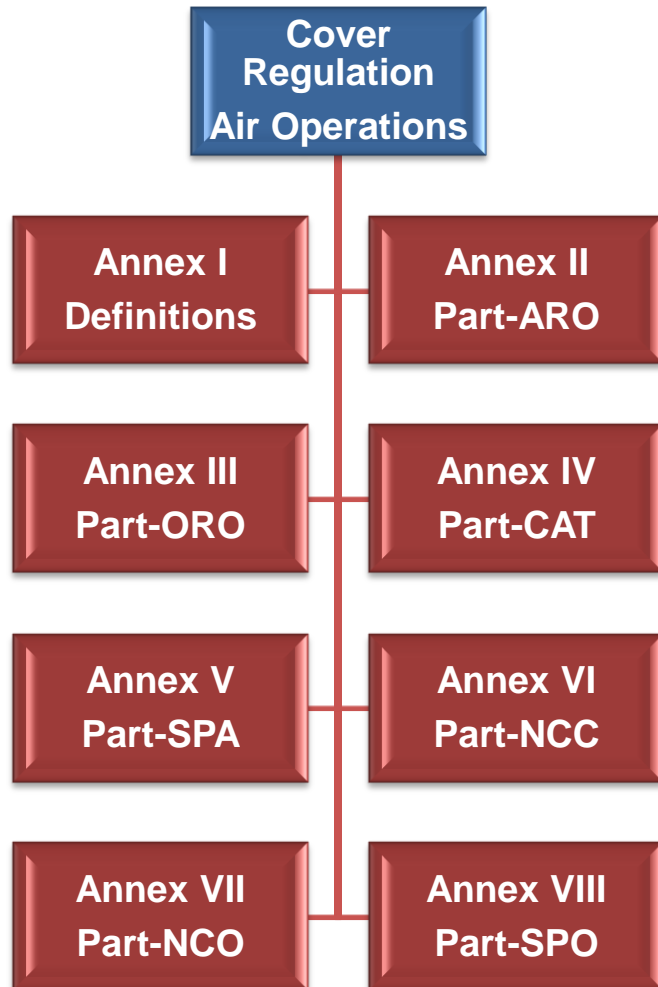

- **Part-ARO:** Authority Requirements Operations
- **Part-ORO:** Organisation Requirements Operations
- **Part-CAT:** Commercial Air Transport operations
- **Part-SPA:** Operations requiring Specific Approvals
- **Part-NCC:** Non-commercial operations with complex motor-powered aircraft
- **Part-NCO:** Non-commercial operations with other-than-complex motor-powered aircraft
- **Part-SPO:** Specialised Operations, e.g. aerial work

Annexes applicable to NCC operations

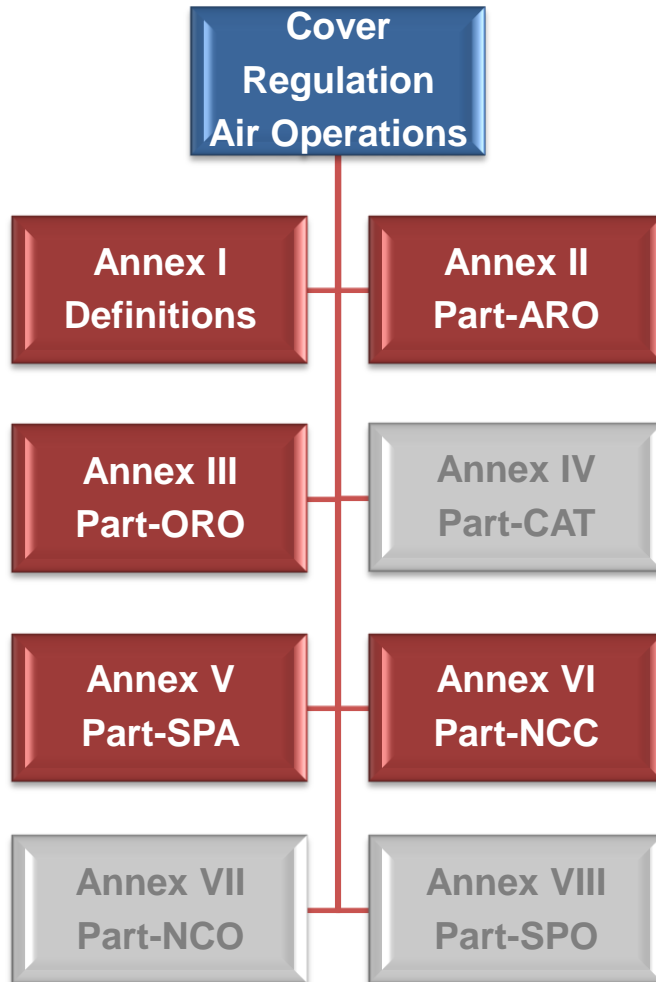

- **Part-ARO:** Authority Requirements Operations
- **Part-ORO:** Organisation Requirements Operations
- **Part-CAT:** Commercial Air Transport operations
- **Part-SPA:** Operations requiring Specific Approvals
- **Part-NCC:** Non-commercial operations with complex motor-powered aircraft
- **Part-NCO:** Non-commercial operations with other-than-complex motor-powered aircraft
- **Part-SPO:** Specialised Operations, e.g. aerial work

What does this mean for you?

- The Regulations are structured differently to previous National Rules
- Make sure you are familiar with these Regulations as they apply to NCC Operators
- Part-NCC is not the only Annex of the Regulation which is applicable



Annex III Part-ORO

Air Operations – Annex III Part-ORO

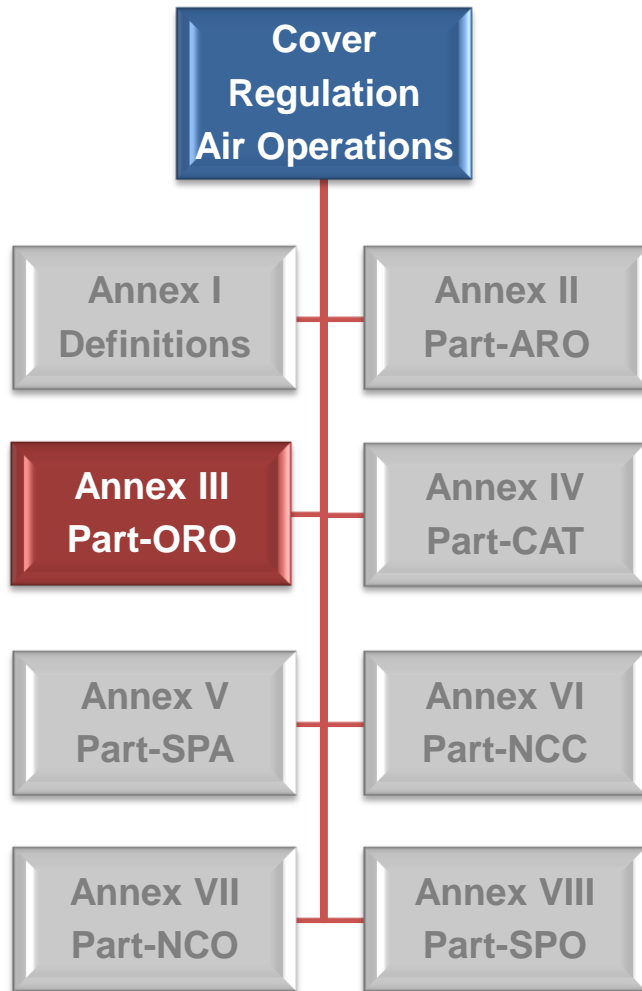

▪ **Applicability:**

- Organisation requirements for:
 - CAT operators
 - NCC operators
 - SPO operators:
 - Commercial operations
 - Non-commercial operations with complex aircraft

Part-ORO - Rule Structure

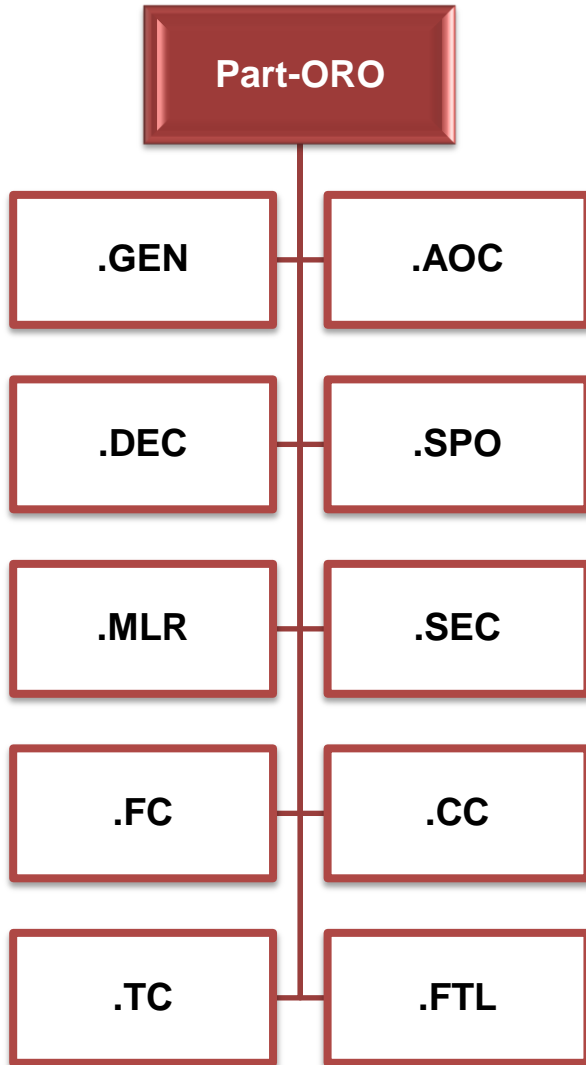

.GEN general requirements

.AOC air operator certification

.DEC declaration

.SPO commercial specialised operations

.MLR manual, logs, records

.SEC security

.FC flight crew

.CC cabin crew

.TC technical crew

.FTL flight and duty time limitations and rest requirements

Part-ORO - Applicability of Subparts

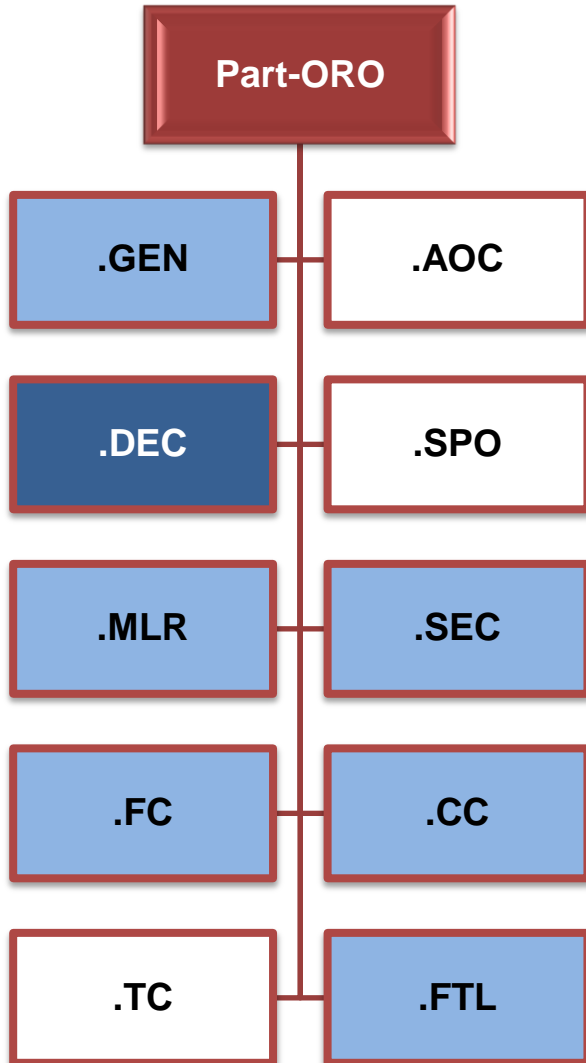

- .GEN** general requirements
- .AOC** air operator certification
- .DEC** declaration
- .SPO** commercial specialised operations
- .MLR** manual, logs, records
- .SEC** security
- .FC** flight crew
- .CC** cabin crew
- .TC** technical crew
- .FTL** flight and duty time limitations and rest requirements (*yet to be developed*)

Applicability for NCC

Full	Partial	Nil
------	---------	-----

Part-ORO.GEN

- **Includes:**
 - Management system
 - “The operator shall establish, implement and maintain a management system that includes:
 - “The management system shall correspond to the size of the operator and the nature and complexity of its activities, taking into account the hazards and associated risks inherent in these activities.”
 - AMC and Guidance Material expands for both complex and non-complex operators

Part-ORO.MLR

- **Includes:**
 - Operations manual (OM)
 - Structure and content
 - Minimum equipment list (MEL)
 - Record keeping requirements

Part-ORO.SEC

- Flight crew compartment security

Part-ORO.FC

- **Includes:**
 - Composition of flight crew
 - Designation as pilot-in-command
 - Crew resource management (CRM)
 - Operator conversion training
 - Recurrent training and familiarisation training
 - Operation on more than one type or variant

Part-ORO.CC

- **Includes:**
 - Number and composition of cabin crew
 - Initial training course
 - Aircraft specific training and operator conversion training
 - Recurrent training

Part-ORO.DEC

ORO.DEC.100 Declaration

The non-commercial operator of complex motor-powered aircraft shall:

- (a) provide the competent authority with all relevant information prior to commencing operations, using the form contained in Appendix I to this Annex;
- (b) notify to the competent authority a list of the alternative means of compliance used;
- (c) maintain compliance with the applicable requirements and with the information given in the declaration;
- (d) notify the competent authority without delay of any changes to its declaration or the means of compliance it uses through submission of an amended declaration using the form contained in Appendix I to this Annex; and
- (e) notify the competent authority when it ceases operation.

Part-ORO.DEC

- **Intent of the declaration**

- Have the operator acknowledge its responsibilities under the applicable safety regulations and that it holds all necessary specific approvals
- Inform the competent authority of the existence of an NCC operator
- Enable the competent authority to fulfil its oversight responsibilities

- **Managed operations**

- When the aircraft is managed by a third party on behalf of the owner, that party may be the operator and has to submit the declaration

Part-ORO.DEC

Declaration Form

Items on the form:

- Operator data
- Continued airworthiness data
- Aircraft operation data
- Details of specific approvals
- List of alternative means of compliance
- Statements on the compliance with applicable rules
- Information on industry standards, if applicable

Part-ORO.AOC

ORO.AOC.125 Non-commercial operations of aircraft listed in the operations specifications by the holder of an AOC

- (a) The holder of an AOC may conduct non-commercial operations with an aircraft otherwise used for commercial air transport operations that is listed in the operations specifications of its AOC, provided that the operator:
 - (1) describes such operations in detail in the operations manual, including:
 - (i) identification of the applicable requirements;
 - (ii) a clear identification of any differences between operating procedures used when conducting commercial air transport and non-commercial operations;
 - (iii) a means of ensuring that all personnel involved in the operation are fully familiar with the associated procedures;
 - (2) submits the identified differences between the operating procedures referred to in (a)(1)(ii) to the competent authority for prior approval.
- (b) An AOC holder conducting operations referred to in (a) shall not be required to submit a declaration in accordance with this Part.

What does this mean for you?

- Part-ORO contains detailed organisation rules with which you must comply
- A declaration must be made to the appropriate Competent Authority (CAA in the UK)
- Declaration process will be available in 2016
- AOC holders do not need to make a declaration if compliant with ORO.AOC.125



Annex VI Part-NCC

Air Operations – Annex VI Part-NCC

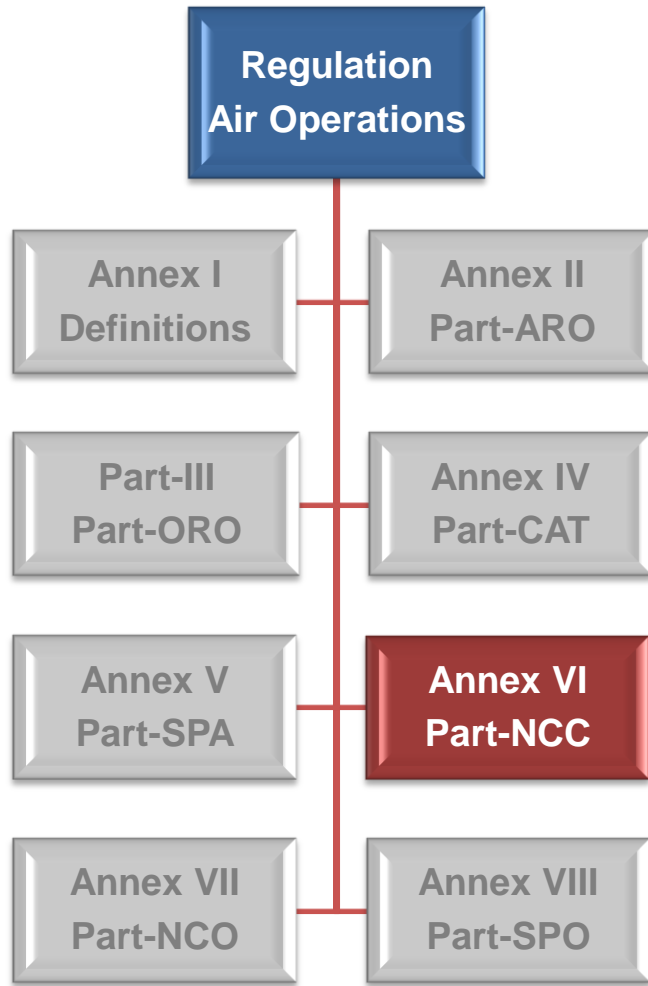

- **Applicability:**
 - Technical rules for:
 - non-commercial operations of complex motor-powered aircraft

Annex IV Part-NCC - Rule Structure

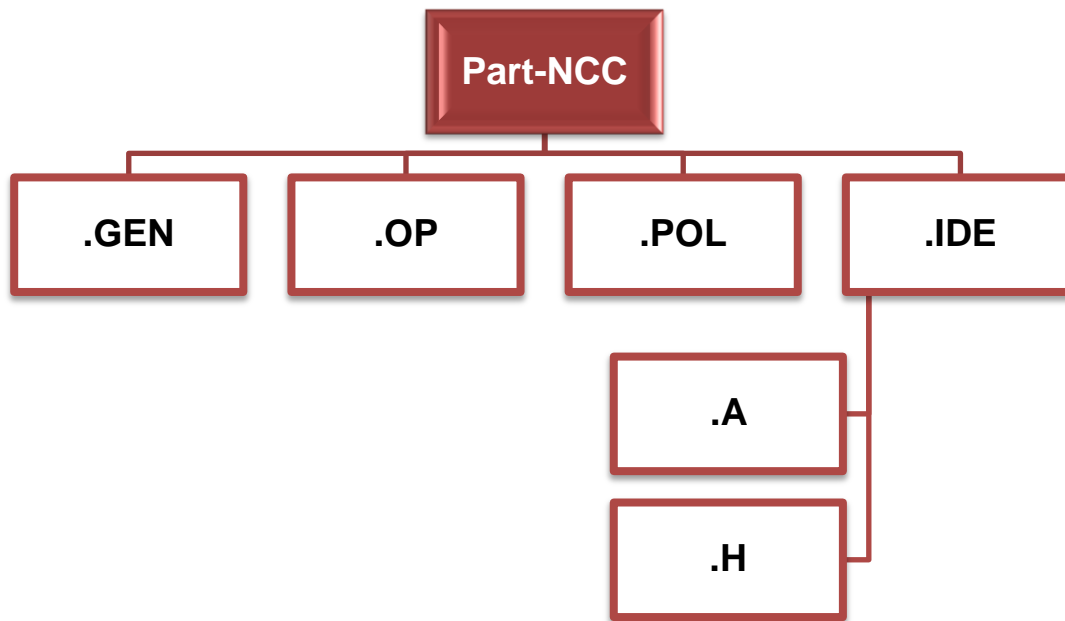

.GEN – general requirements

.OP – operational procedures

.POL – performance and
operating limitations

.IDE – instruments, data,
equipment

.A - aeroplanes

.H - helicopters

Part-NCC.GEN

- **Includes:**
 - Crew responsibilities
 - Pilot-in-command responsibilities
 - Compliance with laws and regulations
 - Taxiing of aircraft
 - Portable electronic devices
 - Documents, manuals and information to be carried
 - Preservation and production of documents
 - Transport of dangerous goods

Part-NCC.OP

- **Includes:**
 - Aerodrome operating minima
 - Departure and approach procedures
 - Noise abatement procedures
 - Flight preparation (Flight Planning)
 - Carriage of passengers
 - In-flight fuel management
 - Ground proximity detection
 - Airborne collision avoidance system (ACAS)

Part-NCC.POL

- **Includes:**
 - Operating limitations (AFM, OM)
 - Mass and balance, loading
 - Performance (general and aeroplane specific)
 - Take off mass limits
 - En-route one engine inoperative

Part-NCC.IDE (Aeroplanes and Helicopters)

- **Includes:**
 - Instruments and equipment
 - Operations under VFR and IFR
 - FDRs/CVRs
 - Supplemental oxygen
 - Survival equipment
 - ELTs
 - Seats, safety belts, restraint systems
 - Radio communication equipment

What does this mean for you?

- Part-NCC contains detailed operating rules, performance and equipment requirements which you must comply with
- To help you comply, there are Acceptable Means of Compliance and Guidance Material
- Alternative Means of Compliance may be used subject to them meeting the intent of the rule and being advised to the CAA



Annex V Part-SPA

Annex V Part-SPA

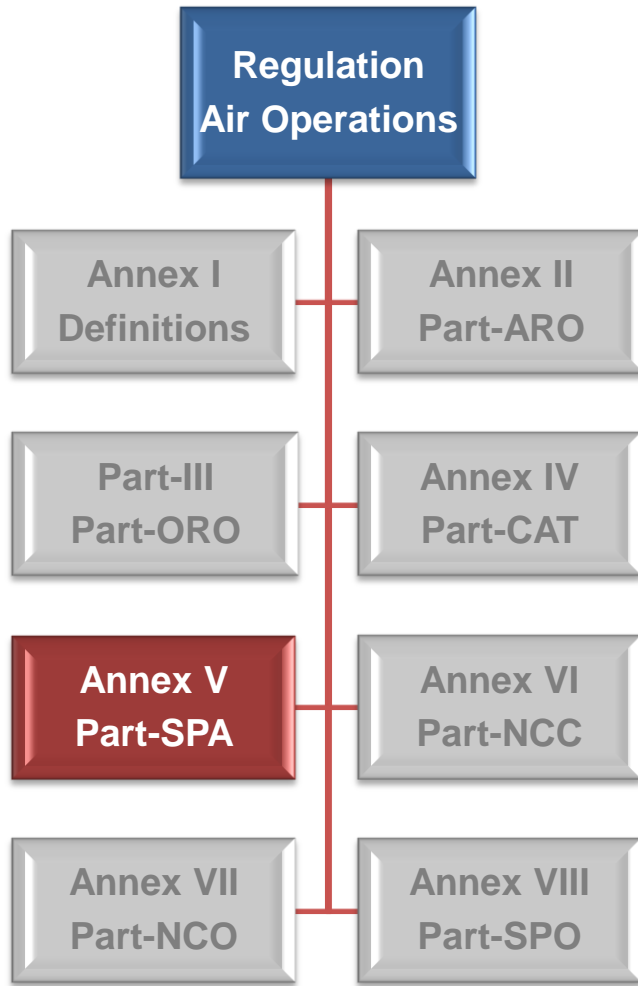

- **Applicability:**

- Operators which wish to conduct an operation requiring a Specific Approval
- To be documented in:
 - OPSPECS for certified operators
 - List of specific approvals for non-certified operators

Part-SPA – Rule Structure & NCC Applicability

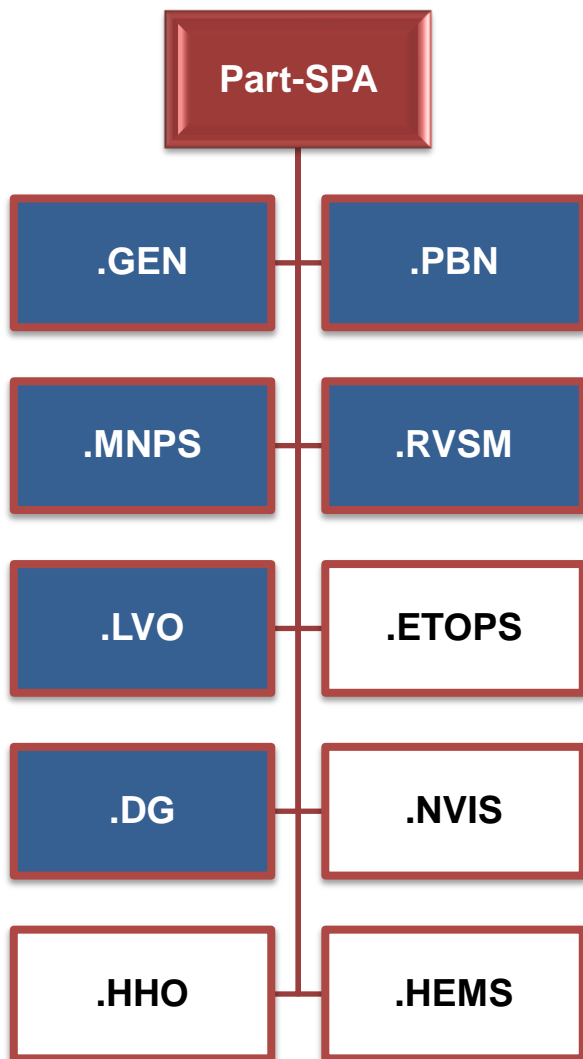

.GEN – general requirements

.PBN – performance based navigation

.MNPS – minimum navigation performance specifications

.RVSM – reduced vertical separation minima

.LVO – low visibility operations

.ETOPS – extended range operations with two-engined aeroplanes (CAT only)

.DG – dangerous goods

.NVIS – night vision imaging systems (CAT only)

.HHO – helicopter hoist operations (CAT only)

.HEMS – helicopter emergency medical services (CAT only)

Full	Partial	Nil
------	---------	-----

Part-SPA.GEN

- **Competent Authority (SPA.GEN.100)**
 - 965/2012 uses the State of the operator principle
 - The competent authority for issuing a specific approval for non-commercial operators shall be the State in which the operator is established or residing
 - For non-commercial operators using an aircraft registered in a non-EU country, the rules for the approval of PBN, MNPS and RVSM do not apply, if the State of the registry issued approvals for such operations
- **List of Specific Approvals (SPA.GEN.110)**
 - Approvals have to be documented in the list of specific approvals, issued by the competent authority
 - The operator has to carry the document on board the aircraft

Part-SPA.GEN

- **Changes (SPA.GEN.115)**
 - Any change to the conditions of a specific approval requires a prior approval of the competent authority
 - This also includes alternative means of compliances developed by the operator

- **Validity (SPA.GEN.120)**
 - Specific approvals are issued for an unlimited duration
 - This also implies that the competent authority provides continuous oversight over such operations

What does this mean for you?

- Part-SPA contains details of activities which must have **prior** approval before being undertaken
- SPA approvals must be included in the Declaration and applied accordingly
- Operations Manual procedures should be developed appropriately and may need to be supplied with approval application
- Individual aircraft must have the required equipment and necessary airworthiness approvals



Annex II Part-ARO

Annex II Part-ARO

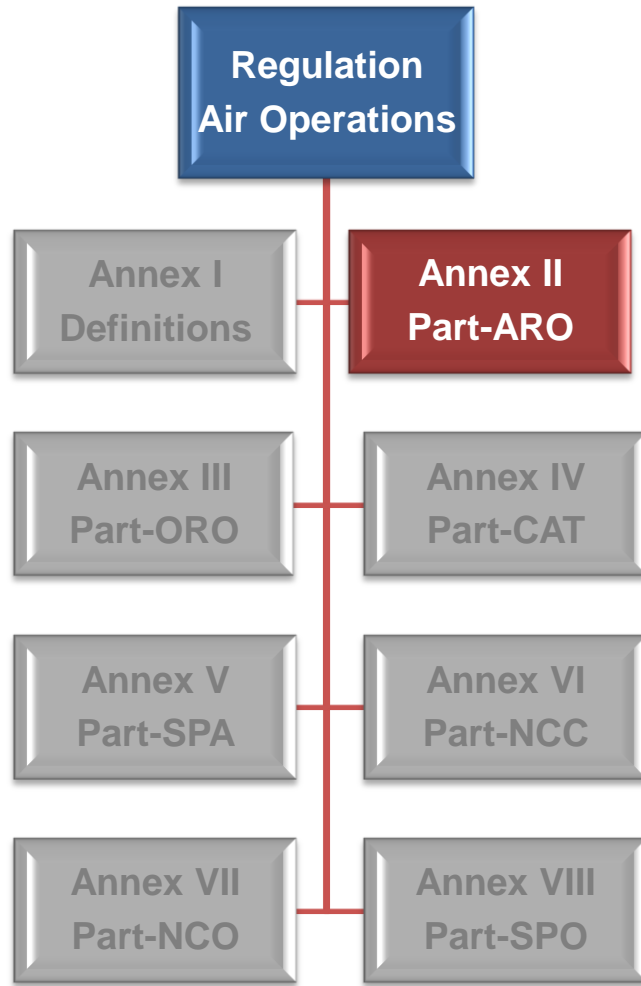

- **Applicability:**

- Authority Requirements for Air Operations for:
 - Competent Authorities (National Aviation Authorities)
 - EASA

Part-ARO – Rule Structure

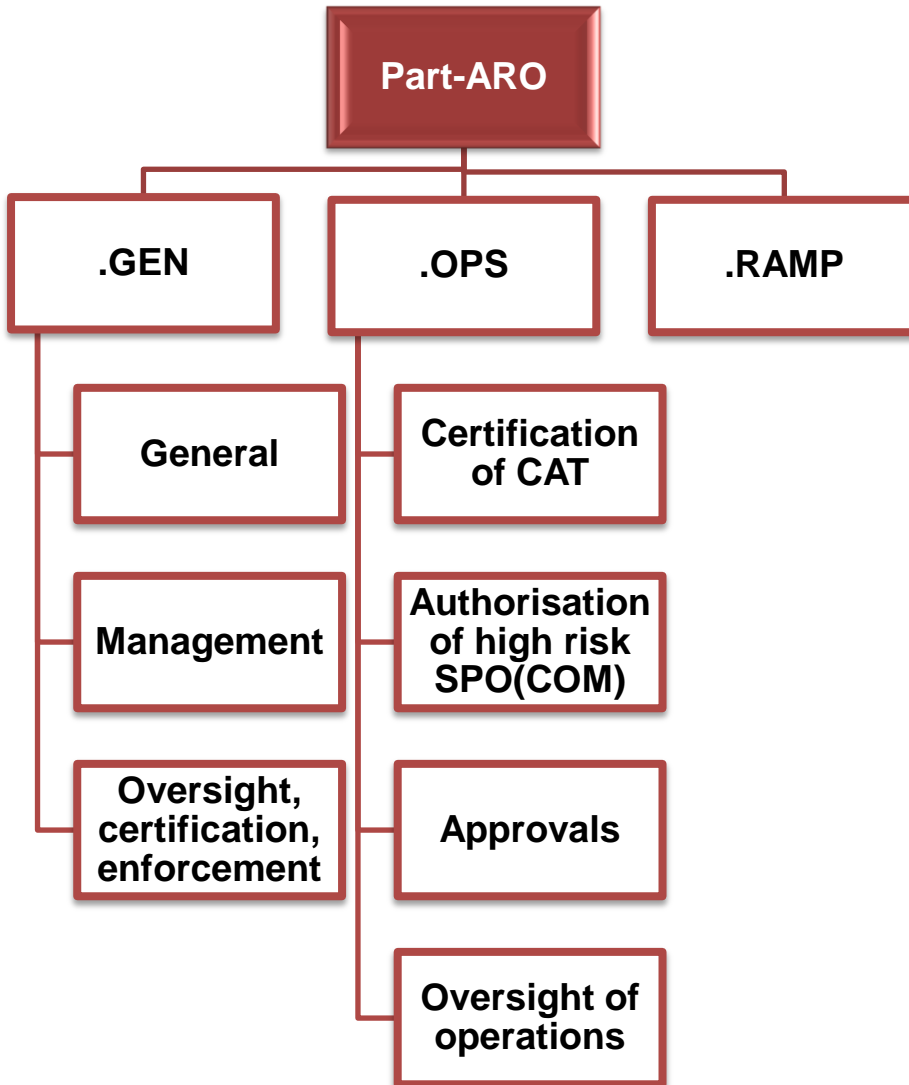

ARO Authority Requirements

.GEN general requirements

.OPS air operations

.RAMP ramp inspections

Part-ARO – Specific Rules for NCC Operations



- **Oversight (ARO.GEN.300 & 305)**
 - The competent authority shall verify continued compliance with the applicable requirements of organisations from whom it received a declaration
 - The competent authority shall establish and maintain an oversight programme; for declared organisations it shall:
 - take into account the specific nature of the organisation, the complexity of its activities and the results of past oversight activities
 - be based on the assessment of associated risks
 - include audits and inspections, including ramp and unannounced inspections, as appropriate

Part-ARO – Specific Rules for NCC Operations



- **Oversight (AMC to ARO.GEN.300)**
 - For NCC operators holding operational approvals for operations in PBN, MNPS or RVSM airspace issued by a non-EU State of Registry:
 - the competent authority should assess the ICAO compliance and capabilities of the non-EU State of Registry

Part-ARO – Specific Rules for NCC Operations



- **Oversight (AMC to ARO.GEN.305)**
 - At least one inspection should be performed within each 48-month cycle starting with the date of the first declaration received.
 - Additional audit/inspections to specific operators may be included in the oversight programme on the basis of the assessment of associated risks carried out within the occurrences reporting scheme(s).
 - Oversight programme should include a certain percentage of unannounced inspections
 - For organisations having demonstrated compliance with industry standards, the competent authority may adapt its oversight programme, in order to avoid duplication of specific audit items

Part-ARO – Specific Rules for NCC Operations



- **Declaration (ARO.GEN.345)**
 - Upon receiving a declaration, the competent authority shall verify that the declaration contains all the information required by Part-ORO and shall acknowledge receipt of the declaration
 - If the declaration does not contain the required information or indicates non-compliance with applicable requirements, the competent authority shall:
 - notify the organisation about the non-compliance and request further information
 - carry out an inspection, if deemed necessary
 - issue findings and request corrective actions, if the non-compliance is confirmed

Part-ARO – Specific Rules for NCC Operations



▪ FINDINGS (ARO.GEN.350)

- A level 1 finding shall be issued when any significant non-compliance is detected which lowers safety or seriously hazards flight safety.
- The level 1 findings shall include:
 - (1) failure to give the competent authority access to the organisation's facilities during normal operating hours and after two written requests;
 - (2) obtaining or maintaining the validity of the organisation certificate or specialised operation authorisation by falsification of submitted documentary evidence;
 - (3) evidence of malpractice or fraudulent use of the organisation certificate or specialised operation authorisation; and
 - (4) the lack of an accountable manager.
- A level 2 finding shall be issued when any non-compliance is detected with the organisation's procedures and manuals or with the terms of an approval, certificate, specialised operation authorisation or with the content of a declaration which could lower safety or hazard flight safety.

What does this mean for you?

- These are new requirements with which the CAA must comply
- This will result in additional active oversight of your operations



ENFORCING REGULATIONS

“As the UK’s specialist aviation regulator, the CAA’s sole purpose is to protect the interests of the consumers and the public. This goal is central to our work in safety, market regulation and consumer protection, and in relation to airspace and the environment. Our ambition is that routine compliance with civil aviation rules and regulations is the norm.

We recognise, though, that we have not yet reached that position and that **we must continue to take action to detect and respond to breaches of civil aviation requirements. Our purpose in taking action is to ensure that consumers and the public can benefit from an aviation industry that is safe and sustainable and provides choice and value”**

A handwritten signature in black ink that reads 'Andrew Haines'.

Andrew Haines, CAA Chief Executive

Enforcement is...

Any activity that is carried out in order to seek to effectively remedy a breach, or suspected or potential breach, of rules applicable to civil aviation

And the CAA will do it by...

- Using a proportionate and risk-based approach
- Taking independent, evidence-based decisions
- Publicising our enforcement action in the interests of the consumer and the public

COLLABORATION AND FACILITATION

- Day to day interaction with those we regulate

ADVISORY

- Guidance to regulated parties
- Verbal warnings
- Using publicity to highlight issues and encourage compliance

FORMAL ENFORCEMENT TOOLS

- Audit findings
- Warning letter
- On Notice
- 'No-fly' Directions
- Variation of certificate, licence or approval
- Suspension of certificate, licence or approval
- Revocation of certificate, licence or approval
- Formal caution
- Conditional caution
- Prosecutions

Scenarios



During an audit of an AOC holder, it is found that the returned flight documentation has not been completed correctly in a number of cases.

Enforcement action: Level 2 finding, i.e. no immediate risk to safety.

Corrective action: Expected within 90 days.

During an audit of an AOC holder, it is found that system for monitoring the training records of crews has failed & pilots' recurrent training and tests have not been revalidated.

Enforcement action: Level 1 finding, i.e. a potential of significant risk to flight safety; possible suspension or part suspension of the AOC.

Corrective action: Crews affected unable to fly until recurrent training & tests revalidated; short-term corrective action required to ensure no other crews are rostered when out of check; longer term corrective action required to re-establish a robust monitoring system.

Information received that records have been falsified.

Enforcement action: Possible suspension or part suspension of AOC; referral for criminal investigation.

Corrective action: Cessation of activities reliant upon the falsified records until falsely recorded events re-taken, repeated or confirmed; individuals involved removed from the process.

Some criminal offences

- Making a false declaration to obtain a licence, AOC, approval, certificate, etc.
 - Knowingly making a false entry or material omission from a record required to be kept under aviation law.
 - Operating a UK-registered aircraft otherwise than in accordance with the terms of an AOC or approval.
 - Operator causing or permitting flight crew to fly knowing or having reason to believe person is likely to suffer from such fatigue as may endanger the aircraft or occupants.
- = Maximum sentence: 2 years imprisonment and/or an unlimited fine**



Safety Culture

What does an OM and Declaration bring?

- A Management System
- An Operations Manual with SOPs
- An opportunity to define an operating standard

The Fundamental Requirement of Safety Management

- Success in a company's safety performance will be greatly strengthened by the existence of a **positive safety culture**.
- Safety culture in an organisation can be described as the way in which it conducts its business and particularly in the way it manages safety.

“What people at all levels in an organisation do and say when their commitment to safety is not being scrutinised”



**Safety
Culture**

“The product of individual and group values, attitudes, perceptions, competencies and patterns of behaviour that can determine the commitment to, and the style and proficiency of an organisation’s safety management system”

**A well known and respected placard
within a UK corporate aircraft**

**Take No Risks
Say NO if you
need to**

We all recognise those who do things 'differently' to others in aviation

- Those that manage to 'get in' when the weather is very poor
- Those that always make the venue no matter what
- Those that are constantly hiring and firing staff

**Can we really
change our
attitudes towards
safety?**

Safety Culture

- NCC operators have the potential to improve safety using the same concepts as AOC operators
- The lack of infrastructure may sometimes make it more difficult, but the concepts are still valid

Safety Culture

- Training
 - Use of simulators
 - Operational Suitability Data (OSD)
 - SOPs
- Multi-pilot crewing can be challenging with a very small team.
- Automation training – Flight Crew Operating Manuals.
- Crew resource management training
- Threat and error management training
- Mindset- there may be resistance to implementing some of these ideas, especially ones clearly brought from the large air carrier community. They may be viewed as unnecessary or inappropriate – **culture!**

Don't forget!

- Details on CAA website:
 - www.caa.co.uk/NCC
- EASA website:
 - <http://easa.europa.eu/easa-and-you/general-aviation/operations-general-aviation>
 - <http://easa.europa.eu/regulations>