

CAP 731

Approval, Operational Serviceability and Readout of Flight Data Recorder Systems and Cockpit Voice Recorders

CAP 731

Approval, Operational Serviceability and Readout of Flight Data Recorder Systems and Cockpit Voice Recorders

© Civil Aviation Authority 2011

All rights reserved. Copies of this publication may be reproduced for personal use, or for use within a company or organisation, but may not otherwise be reproduced for publication.

To use or reference CAA publications for any other purpose, for example within training material for students, please contact the CAA at the address below for formal agreement.

ISBN 978 0 11792 445 1

First published 28 May 2004

Second Edition 3 July 2006

Third Edition 25 March 2011

Enquiries regarding the content of this publication should be addressed to:
Aircraft Systems and Equipment Section, Engineering Department, Safety Regulation Group, Civil Aviation Authority, Aviation House, Gatwick Airport South, West Sussex, RH6 0YR.

The latest version of this document is available in electronic format at www.caa.co.uk, where you may also register for e-mail notification of amendments.

Published by TSO (The Stationery Office) on behalf of the UK Civil Aviation Authority.

Printed copy available from:

TSO, PO Box 29, Norwich NR3 1GN
Telephone orders/General enquiries: 0844 477 7300
Fax orders: 0870 600 5533

www.tsoshop.co.uk
E-mail: caa@tso.co.uk
Textphone: 0870 240 3701

List of Effective Pages

Chapter	Page	Date	Chapter	Page	Date
	iii	25 March 2011	Appendix B	15	25 March 2011
Contents	1	25 March 2011	Appendix C	1	25 March 2011
Contents	2	25 March 2011			
Chapter 1	1	25 March 2011			
Chapter 2	1	25 March 2011			
Chapter 3	1	25 March 2011			
Chapter 4	1	25 March 2011			
Chapter 5	1	25 March 2011			
Chapter 5	2	25 March 2011			
Chapter 5	3	25 March 2011			
Chapter 5	4	25 March 2011			
Chapter 5	5	25 March 2011			
Chapter 6	1	25 March 2011			
Chapter 6	2	25 March 2011			
Chapter 7	1	25 March 2011			
Chapter 7	2	25 March 2011			
Chapter 7	3	25 March 2011			
Chapter 7	4	25 March 2011			
Chapter 7	5	25 March 2011			
Chapter 7	6	25 March 2011			
Chapter 7	7	25 March 2011			
Chapter 8	1	25 March 2011			
Chapter 8	2	25 March 2011			
Chapter 8	3	25 March 2011			
Chapter 8	4	25 March 2011			
Chapter 9	1	25 March 2011			
Chapter 10	1	25 March 2011			
Chapter 11	1	25 March 2011			
Chapter 12	1	25 March 2011			
Chapter 12	2	25 March 2011			
Chapter 12	3	25 March 2011			
Appendix A	1	25 March 2011			
Appendix B	1	25 March 2011			
Appendix B	2	25 March 2011			
Appendix B	3	25 March 2011			
Appendix B	4	25 March 2011			
Appendix B	5	25 March 2011			
Appendix B	6	25 March 2011			
Appendix B	7	25 March 2011			
Appendix B	8	25 March 2011			
Appendix B	9	25 March 2011			
Appendix B	10	25 March 2011			
Appendix B	11	25 March 2011			
Appendix B	12	25 March 2011			
Appendix B	13	25 March 2011			
Appendix B	14	25 March 2011			

INTENTIONALLY LEFT BLANK

Table of Contents

Chapter 1	Introduction	
Chapter 2	Document Structure	
Chapter 3	Reference Material	
Chapter 4	List of Abbreviations	
Chapter 5	Interpretation of Current Operational Rules	
	Introduction	1
Chapter 6	Tasks Prior to Certificate of Airworthiness Issue	
	Type Certification and Supplemental Type Certification	1
	Certificate of Airworthiness (C of A) Issue	1
Chapter 7	FDR System Serviceability and Readout	
	Introduction	1
	Performing/Selecting a Representative Flight	2
	Providing FDR Data, Representative Flight Details, DFLs and Conversion Data	3
	Establishing Limitations of the Readout	3
	Establishing Revision and Applicability of DFLs and Conversion Data	4
	Replaying the FDR Recorded Data	5
	Reporting the FDR Readout Results	5
	Assessment of the FDR Readout Results	6
	Retention and Control of FDR Readout Results	7
Chapter 8	General Requirements for a Readout/Replay Facility	
	Introduction	1
	Required Procedures	1
	Control of DFLs	3
	Staff Competence	4
	Additional Requirements for CVR Replay Facility	4

Chapter 9	Release Certification of Readouts	
Chapter 10	General Guidance on FDM	
	General	1
Chapter 11	Timescales	
Chapter 12	Cockpit Voice Recorders (CVR) Maintenance and Continued Airworthiness	
	CAA Recommendations	1
Appendix A	Flight Data Recorder Compliance Document	
Appendix B	Example FDR Replay Support Documents	
	Introduction to Data Frames	1
	What is a Data Frame?	1
	Data Frame Structure	2
	Data Conversions	3
Appendix C	Guidance on FDR Validation	

Chapter 1 Introduction

Aviation legislation in the UK reflects the ICAO Standards and requires that certain categories of aircraft are equipped with crash protected Flight Data Recorder (FDR) systems and Cockpit Voice Recorder (CVR) systems. These systems are installed primarily to assist investigations into incidents and accidents or, additionally, either by using the FDR or via a secondary quick access recorder, a number of operators monitor certain operational aspects of their aircraft.

To satisfy legal requirements the installations have to comply with the appropriate minimum requirements dependent upon the class of aircraft. Continued serviceability requires compliance with the installer's maintenance instructions as well as validation of data recorded in-flight. This document provides general advice and guidance to operators of aircraft equipped with FDRs and to the facilities that provide an FDR data readout service of their respective responsibilities to achieve correlation of this activity.

This document has been published to address a number of AAIB recommendations and to take into account EASA Safety Information Bulletin (SIB) No. 2009-28, that relate to partial/complete un-serviceability of recorders and/or incorrectly installed recorders.

Examples of AAIB Recommendations are detailed below:

a) 97-69

The aircraft operator shall ensure that the facility conducting the readout is provided with a copy of the data frame layout document applicable to the installation to be addressed.

b) 97-70

Organisations conducting scheduled mandatory readouts from a Digital Flight Data Recorder (DFDR) have procedures in place to ensure that all information within a data frame layout document is correctly interpreted, used for a scheduled mandatory readout of the relevant recording installation and that any assessment is conducted only on data that has been converted to engineering units. Furthermore, any report issued by the organisation shall reference both by document number and issue status the data frame layout document against which the readout was performed.

At the time of publication, references to JAR documents and the Air Navigation Order were still valid. However, these documents may be superseded by equivalent EASA documents.

NOTE: With regard to FDRs and CVRs, operators are requested to revise their maintenance programmes to include an annual report and validation of recorded data for accuracy and duration to comply with this CAP 731 under the provisions of Part M Subpart C M.A.302(c)2.

INTENTIONALLY LEFT BLANK

Chapter 2 Document Structure

The following discrete issues are addressed within this document:

- a) Simple guidance on the interpretation of the current operational rules.
- b) What is required to be established prior to the issuance of the Certificate of Airworthiness (C of A) for individual aircraft.
- c) The need to identify scheduled tasks - to ensure the continuing serviceability of the FDR system whilst the aircraft is in operational service.
- d) Who has what responsibility and what should happen when the annual FDR readout is accomplished in accordance with Air Navigation Order 2009, Articles 153, 154 and 155 (as amended).

INTENTIONALLY LEFT BLANK

Chapter 3 Reference Material

- 1 ICAO Annex 6 – Operation of Aircraft (Flight Recorders)
 - Part I, Chapter 6, paragraph 6.3 and Attachment D
 - Part II, Chapter 6, paragraph 6.10 and Attachment A
 - Part III, Section II, Chapter 4, paragraph 4.3
 - Part III, Section III, Chapter 4, paragraph 4.9 and Attachment B
- 2 ICAO Annex 6 – Operation of Aircraft (Flight Recorder Records)
 - Part I, Chapter 11, paragraph 11.6
 - Part II, Chapter 6, paragraph 6.10.9
 - Part III, Section II, Chapter 9, paragraph 9.6
- 3 CAP 739 Flight Data Monitoring
- 4 Air Navigation Order 2009, Articles 153, 154, 155 and Schedule 4 Scales P, S and SS
- 5 CAA Specifications 10, 10A, 11 and 18
- 6 Commission Regulation (EC) 2042/2003 ANNEX I (Part M) and ANNEX II (Part 145)
- 7 CS/JAR-23, 25, 27 and 29 paragraph 1459 (Flight Recorders)
- 8 EU-OPS 1 and JAR-OPS 3 subpart K paragraphs 1/3.715 to 1/3.725 (Flight Data Recorders)
NOTE: NPA-OPS 25 clarifies the current rule and adds paragraph 727 (Combined Recorders) to EU-OPS 1. Additionally, a further NPA, which will be released in the future, will add paragraph 1.712 to EU-OPS 1 to address ICAO Type IA Recorders.
- 9 EU-OPS 1 and JAR-OPS 3 paragraph 1/3.160 Presentation, Production and use of flight recorder recordings
- 10 EU-OPS 1 paragraph 1.037 (Operational Flight Data Monitoring)
- 11 EUROCAE Document ED-55 (and subsequent versions) "Minimum Operational Performance Specification for Flight Data Recorder Systems"
- 12 EUROCAE Document ED-112 (and subsequent versions) "Minimum Operational Performance Specification for Crash Protected Airborne Recorder Systems"
- 13 EASA SIB 2009-28

INTENTIONALLY LEFT BLANK

Chapter 4 List of Abbreviations

AAIB	Air Accident Investigation Branch
AFCS	Automatic Flight Control System
ANO	Air Navigation Order
ARINC	Aeronautical Radio Inc
BCAR	British Civil Airworthiness Requirements
CAA	Civil Aviation Authority
CAME	Continuing Airworthiness Management Exposition
C of A	Certificate of Airworthiness
CVFDR	Combined Voice Flight Data Recorder
CVR	Cockpit Voice Recorder
DFDAU	Digital Flight Data Acquisition Unit
DFDR	Digital Flight Data Recorder
DFL	Data Frame Layout Document
EASA	European Aviation Safety Agency
ED	EUROCAE Document
EUROCAE	European Organisation for Civil Aviation Equipment
FDM	Flight Data Monitoring
FDR	Flight Data Recorder
HHUMS	Helicopter Health and Usage Monitoring Systems
ICAO	International Civil Aviation Organisation
JAA	Joint Aviation Authorities
JAR	Joint Aviation Requirements
LLDC	Low Level DC
LRU	Line Replaceable Unit
MEL	Minimum Equipment List
MME	Maintenance Management Exposition
MMEL	Master Minimum Equipment List
MOE	Maintenance Organisation Exposition
NPA	Notice of Proposed Amendment
OQAR	Optical Quick Access Recorder
QAR	Quick Access Recorder
STC	Supplemental Type Certification/Certificate
TC	Type Certification/Certificate
Vsn	Version
WPS	Words Per Second

INTENTIONALLY LEFT BLANK

Chapter 5 Interpretation of Current Operational Rules

1 Introduction

The following tables provide simple guidance on how to interpret the operational requirements relating to the installation of Flight Recorders. They specify when a flight recorder has to be carried, how long its recording duration should be and provide reference data for the required FDR parameters.

It should be noted that this information is for guidance purposes only, and that reference should be made to the appropriate operational rules as these are the definitive source of the requirement.

The following tables are current at the time of publication of this document only and should not be used in preference to the actual operational rules.

The tables are provided in the following order:

- a) Tables relating to the Air Navigation Order
- b) Tables relating to EU-OPS 1
- c) Tables relating to JAR-OPS 3

The tables do not attempt to list the sets of mandatory parameters as these are explicitly detailed in the operational requirements.

1.1 Air Navigation Order 2009 – Scale P

Type Cert Issued Anywhere	Weight in Kilogrammes	Turbine Engined		Piston Engined	
		Transport Cat. Passenger/ Cargo	Special Cat. or 'A' conditions if applied for Transport Cat.	Transport Cat. Passenger/ Cargo	Special Cat. or 'A' conditions if applied for Transport Cat.
Before 1/4/71	$5,700 < X \leq 11,400$	Operated by Air Transport undertaking FDR or CVR	FDR or CVR		
Before 1/4/71	$11,400 < X \leq 230,000$	Operated by Air Transport undertaking FDR and CVR	FDR and CVR		
Before 1/4/71	$27,000 < X \leq 230,000$			Operated by Air Transport undertaking FDR	FDR

- NOTES:**
- 1 All CVRs are required to be 4 Channel CVRs.
 - 2 For the list of parameters to be recorded refer to ANO 2009 Schedule 4 Scale P.
 - 3 'X' refers to the weight of the aircraft in question.

Air Navigation Order 2009 – Scale S

Type Cert. Issued Anywhere	Individual C of A Issued Anywhere	Weight in Kilogrammes	Specific Conditions	ANO Scale	Turbine Engine	Piston Engine
on/after 1/4/71		5,700 < X ≤ 11,400	-	S(1)	FDR or CVR	FDR or CVR
on/after 1/4/71		11,400 < X ≤ 27,000	-	S(2)	FDR and CVR	FDR and CVR
on/after 1/4/71		27,000 < X ≤ 230,000	-	S(3)	FDR and CVR	FDR and CVR
on/after 1/1/70 in UK		X > 230,000	-	S(3)	FDR and CVR	FDR and CVR
	on/after 1/6/90	X ≤ 5,700	2+ Engines and 9+ Pax	S(4)	FDR and CVR or Combined FDR/CVR	
	on/after 1/6/90	5,700 < X ≤ 27,000	-	S(5)	FDR and CVR	FDR and CVR
	on/after 1/6/90	X > 27,000	-	S(6)	FDR and CVR	FDR and CVR
	on/after 1/6/90 for aerial work and Private Cat.	X > 27,000	-	S(6)	FDR and CVR	FDR and CVR

NOTES: 1 All CVRs are required to be 4 Channel CVRs.

2 For the list of parameters to be recorded refer to ANO 2009 Schedule 4 Scale S.

3 'X' refers to the weight of the aircraft in question.

1.3 Air Navigation Order 2009 – Scale SS

Type Cert. Issued	Weight (kg)	Specific Conditions	Scale	Helicopters/Gyroplanes	
				Transport Cat. Passenger/Cargo	Special Cat. or 'A' conditions if applied for Transport Cat.
Applies to all Rotorcraft	$2,730 < X \leq 7,000$	9+ Pax or The Specified Weight	SS(1) or SS(3)	$\frac{1}{2}$ hr CVR + 8hr FDR or Combined 1hr CVR → /8hr FDR or 5hr FDR + 3 hrs Non-Protect FDR Data.	$\frac{1}{2}$ hr CVR + 8hr FDR or Combined 1hr CVR → /8hr FDR or 5hr FDR + 3 hrs Non-Protect FDR Data.
Applies to all Rotorcraft	$X > 7,000$	-	SS(2) or SS(3)	$\frac{1}{2}$ hr CVR + 8hr FDR or Combined 1hr CVR → /8hr FDR or 5hr FDR + 3 hrs Non-Protect FDR Data.	$\frac{1}{2}$ hr CVR + 8hr FDR or Combined 1hr CVR → /8hr FDR or 5hr FDR + 3 hrs Non-Protect FDR Data.

→ 3 Channel CVR Minimum.

NOTES: 1 All CVRs, except those marked →, are required to be 4 Channel CVRs.

2 For the list of parameters to be recorded refer to ANO 2009 Schedule 4 Scale SS.

3 'X' refers to the weight of the aircraft in question.

1.4
EU-OPS 1

EU-OPS 1 Section	Type Certificated After	Individual A/C Cert. Issued Anywhere	Weight in kg	No. T. Eng's	Approved PAX Seating Config	Turbine Powered	Recording Duration	Parameter Definition Table
715 a1 and a2	-	on/after 1/4/98	X > 5,700	2+	> 9	Digital FDR	25 Hrs	See Table A1 or A2 of Appendix 1 to JAR-OPS 1.715
715 b and 727	-	on/after 1/4/98	X ≤ 5,700	-	-	FDR or Combined FDR/CVR	10 Hrs	See Table A1 or A2 of Appendix 1 to JAR-OPS 1.715
720	-	1/6/90 to 31/3/98	5,700 < X ≤ 27,000	-	-	Digital FDR	25 Hrs	See Table A of Appendix 1 to JAR-OPS 1.720
720	-	1/6/90 to 31/3/98	X > 27,000	-	-	Digital FDR	25 Hrs	See Tables A and B of Appendix 1 to JAR-OPS 1.720
725	-	Before 1/6/90	X > 5,700	-	-	Digital FDR	25 Hrs	See Table A of Appendix 1 to JAR-OPS 1.725
725	30/6/69	Before 1/6/90	X > 27,000	-	-	Digital FDR	25 Hrs	See Table A + Parameters 6-15 of Table B of Appendix 1 to JAR-OPS 1.725

NOTES: 1 For details of the variations related to required parameters refer to the latest version of EU-OPS 1.

2 'X' refers to the weight of the aircraft in question.

JAR-OPS 3

JAR-OPS 3 Section	Applicable After	Individual A/C Cert. Issued Anywhere	Weight in kg	Approved PAX Seating Config	Recorder Requirement	Recording Duration	Parameter Definition Table
715	-	on/after 1/8/99	$3,175 < X \leq 7,000$	-	Digital FDR or Combined FDR/CVR	8 Hrs	See Table A of Appendix 1 to JAR-OPS 3.715 + Table C of Appendix 1 to JAR-OPS 3.715 for rotorcraft with electronic display systems
715	-	on/after 1/8/99	$X > 7,000$	-	Digital FDR or Combined FDR/CVR	8 Hrs	See Table A of Appendix 1 to JAR-OPS 3.715 + Table C of Appendix 1 to JAR-OPS 3.715 for rotorcraft with electronic display systems
720	1/4/2000	1/1/89 to 31/7/98	$X \leq 7,000$	or > 9	Digital FDR or Combined FDR/CVR	5 Hrs	See Table A of Appendix 1 to JAR-OPS 3.720 + Table C of Appendix 1 to JAR-OPS 3.715 for rotorcraft with electronic display systems
720	1/4/2000	1/1/89 to 31/7/98	$X > 7,000$	or > 9	Digital FDR or Combined FDR/CVR	5 Hrs	See Table B of Appendix 1 to JAR-OPS 3.720 + Table C of Appendix 1 to JAR-OPS 3.715 for rotorcraft with electronic display systems

NOTE: 'X' refers to the weight of the aircraft in question.

INTENTIONALLY LEFT BLANK

Chapter 6 Tasks Prior to Certificate of Airworthiness Issue

The following paragraphs detail the CAA's expectations relating to the replay and validation of CVR and FDR data during the processes related to TC/STC and C of A issue. The order of the paragraphs is intended to reflect the process time line.

1 Type Certification and Supplemental Type Certification

At the time of certification the TC/STC applicant will be expected to demonstrate to the regulatory authority that they have complied with the following:

- a) A cockpit voice recorder and flight data recorder system has been installed in accordance with the agreed aircraft certification basis, taking account of the applicable operational requirements.
- b) Evidence has been provided that demonstrates the installed CVR and FDR system meets the appropriate operational requirements, including accuracy, resolution, range, duration and sampling rates.
- c) The flight data recorder system consists of appropriately approved equipment as required by the applicable operational requirements.
- d) The information necessary to enable operators of aircraft to conduct a readout of the FDR content is provided. As a minimum this shall include a data frame layout document together with any necessary conversion data to enable translation into engineering units.
- e) The information necessary to enable operators to perform scheduled maintenance tasks that demonstrate continued compliance with the certification requirements is provided. This information is expected to address all parts of the CVR and FDR system, for example, the associated sensors.
- f) In order to demonstrate compliance with the initial entry-into-service requirements (e.g. xx.1301) the TC/STC applicant is required to perform the initial CVR and FDR readout and validation.

NOTE: xx refers to the appropriate JAR or EASA Certification Specification requirements e.g. 23, 25, etc.

- g) To comply with the requirements of xx.1529, the TC/STC applicant is required to perform an analysis of the required maintenance activities for the FDR. This must be translated into a list of operator maintenance actions that must be provided to the operator. Further guidance on this is provided in ED-55 and ED-112.

NOTE: xx refers to the appropriate CS/JAR requirements e.g. 23, 25, etc.

2 Certificate of Airworthiness (C of A) Issue

At the time of C of A issue an operator/applicant will be expected to provide evidence that, for the individual aircraft to be certificated, the TC/STC holder has met each of the TC/STC requirements specified above.

The regulatory authority will expect the operator/applicant to provide a compliance statement that demonstrates the following:

- a) A Data Frame Layout Document (DFL) is available for the FDR system.
- b) Conversion Data (to enable translation of raw FDR data to engineering units) is available for the FDR system.
- c) Procedures are in place to provide the DFL and Conversion Data to an appropriate readout facility.
- d) The Aircraft Approved Maintenance Programme/Schedule includes a list of tasks specified by the TC/STC holder to ensure the continued serviceability of the FDR and CVR system.
- e) The FDR Readout from a representative flight, conducted immediately prior to C of A issue, has been evaluated to ensure that the FDR system is functioning correctly.
- f) For a second hand aircraft imported from outside the EU, an examination of the recorded signal on the CVR should be carried out by replay of the CVR recording as required by Chapter 12 paragraph 1.1 b). This requirement applies to both tape based and solid state CVRs and should be carried out immediately prior to issue of the C of A. If this cannot be achieved refer to Note 1 below.

- NOTES:**
- 1 Where an operator experiences a delay such that the results of the readout are not available for validation at the time of C of A issue, the responsible CAA Regional Office should be contacted to agree a specified time scale for its completion. This should normally be within 30 days of the date of C of A issue.
 - 2 Irrespective of the originating source of the aircraft, the FDR system is required to meet the UK operational rules.
 - 3 A template giving the preferred layout for a Compliance Statement Document is provided in Appendix A to this document.
 - 4 Examples and Descriptions of Data Frame Layout Document and Conversion Data are provided in Appendix B to this document.
 - 5 If the aircraft is second-hand or has been transferred and the information can't be obtained via the route specified in Chapter 6, paragraph 1, the applicant should engage the services of a suitably qualified design organisation to facilitate the function that would have otherwise been provided by the TC/STC holder.

Chapter 7 FDR System Serviceability and Readout

1 Introduction

Articles 153, 154 and 155 of the Air Navigation Order 2009 require that operators preserve a record of one representative flight made within the last 12 months. The purpose of this is to ensure that, in the event of an accident/incident, air accident investigators have access to a readout from the flight data recording system that is representative of the actual aircraft condition prior to the accident/incident. It follows that the data originating from the selected representative flight will need to be evaluated to determine that it comprises a valid record.

EASA SIB 2009-28 and ICAO Annex 6 Part I Attachment D provide updated guidance to ensure the continued serviceability of FDR systems.

The Flight Data Recorder readout may be carried out either by an organisation holding an appropriate EASA Part 145 C Rating approval with the additional procedures necessary to perform FDR readout, or by an operator that can demonstrate that they have the required equipment and competence to perform this task. This task may be sub-contracted by the operator, details of which will need to be included in their CAME. The approved organisation is also required to have specific procedures detailing how an FDR readout will be performed and controlled (refer to Appendix C).

The aircraft operator/owner is responsible for ensuring the continued serviceability of the FDR system and retaining the relevant records required by the operational requirements. In addition, the validation of recorded data from a representative flight provides **evidence** of the FDR system performance in a flight dynamic situation that cannot be achieved during ground testing alone. Based on this, the CAA believe that it would be logical and beneficial to use the data required by the ANO to evaluate the continued serviceability of the FDR system.

- NOTES:**
- 1 An operator who conducts their own readout does not need to hold an EASA Part 145 approval, however they will need to conform to the general requirements for a readout facility detailed in Chapter 8 and Appendix C of this CAP; this should be detailed in their CAME. Operators who wish to provide FDR readouts as a service to other operators will need to hold an EASA Part 145 approval with the appropriate C Rating and have additional procedures in their MOE.
 - 2 If a flight data recorder needs to be removed and routed to a Readout Facility to download the required data, the serviceability of the equipment needs to be verified and the equipment released to service by an appropriate EASA Part 145 approved maintenance organisation prior to re-installation in the aircraft.
 - 3 **Calibration of the FDR system**
Guidance referred to in ICAO Annex 6 Part I Attachment D and referenced in the EASA SIB paragraph 3.5 has caused some confusion among industry. The word "calibration" is a term that was used for analogue FDR's. Some of the sensors providing data to the recorders could drift out of tolerance and would require re-calibration. Modern aircraft use digital systems to provide data to the FDR, which normally do not require calibration. The Type Certificate holder should be consulted in the event of any doubt.
 - 4 Whilst a record of the serviceability of the FDR though a readout must be kept to comply with the ANO on an annual basis, operators of aircraft equipped with digital FDR systems that have a high integrity of serviceability self monitoring, may submit to their assigned regional office Surveyor an alternate proposal for having their FDR readout carried out and analysed annually.

Detection of FDR recording anomalies may be achieved in one of two ways:

- a) Validation of recorded data. To be able to validate the data, the readout facility will require details of the tests carried out or of the representative flight.
- b) A combination of scheduled maintenance tasks and validation of recorded data.

2 Performing/Selecting a Representative Flight

2.1 Responsibility

This is the responsibility of the aircraft operator/owner.

2.2 Purpose

The purpose of performing a specific FDR test flight or recording the details of a representative commercial flight is to gain an FDR recording of a flight that can be used to assess the functionality of an FDR. This is intended to obviate the need for readout facilities to make a random determination of a representative flight without the supporting information to ensure a good decision.

NOTE: The intent of this activity is to reduce the amount of ground testing that needs to be performed by the aircraft operator/owner and to make best use of the selected representative flight data. In the event that an operator cannot add to flight crew activities in the manner described below, the missing data will need to be provided via a set of ground tests.

2.3 General Notes

This activity is not intended to force an operator into performing a specific test flight in order to gain FDR serviceability data. It is intended that an operator will select a flight from a regular service that would stimulate as many FDR parameters as practicable.

The appropriate selection of a representative flight and recorded flight details can greatly increase the FDR serviceability information that can be established during FDR readout validation. The flight should endeavour to function discretely that can be operated safely.

NOTE: This does not necessarily require the performance of a specific FDR test flight.

If the information provided by the representative flight is sufficient to establish parameter functionality and reasonableness it may be possible to gain FDR serviceability credit for the parameters concerned.

NOTE: The actual assessment of this will depend upon how much information about the flight is provided to the readout facility. See Chapter 8, paragraph 2.2 for more details on this.

Details of a representative flight per ANO 2009 Articles 153, 154 and 155, which must include a take-off, climb, cruise, descent, approach to landing and landing, together with general details of the flight profile, could be expanded to include:

- Pre-departure checks;
- Flight duration;
- Altitude reached;
- Flight control settings;
- Power settings;
- Flight deck indications;

- AFCS operation

NOTE: EU-OPS 1.720/1.725. Autopilot engagement status is taken to be autopilot operating modes, auto throttle and AFCS system engagement status and operating modes.

- Test warnings (such as GPWS, Stall and TCAS) etc.

The operator should ensure the following:

- a) An appropriate pro-forma is produced to ensure that flight crew perform and record the necessary tasks during the 'representative flight'. This should be provided together with FDR data when requesting a download and validation;
- b) Pre-departure checks that have been selected, as part of the representative flight, are being recorded on the FDR.

NOTE: The level of information gained will depend on when the FDR is powered up and the operator should ensure that the selected information is being recorded;

- c) Aircraft warnings (e.g. engine fire) are included in the FDR content;
- d) The FDR download contains, at a minimum, all the mandatory FDR parameters. The list of mandatory FDRs can be found in the relevant operational rule.

3 Providing FDR Data, Representative Flight Details, DFLs and Conversion Data

3.1 Responsibility

This is the responsibility of the aircraft operator/owner.

3.2 Purpose

The purpose of providing the FDR data and the appropriate supporting data to the readout facility is to enable the generation of the most accurate possible readout of the FDR's content.

3.3 General Notes

The accuracy and assessment of an FDR readout is dependent on the provision of a DFL and associated conversion data. This, in conjunction with details of a representative flight, should enable a meaningful assessment of all/most of the mandatory parameters of the FDR system functionality to be carried out.

4 Establishing Limitations of the Readout

4.1 Responsibility

The responsibility of assessing the supporting information provided with the FDR data and determining how much information can be provided about the FDR system lies with the EASA Part 145 organisation or operator performing the readout.

4.2 Purpose

This task should be performed prior to the readout and its purpose is to establish a clear understanding of the limitations that the readout assessment is able to provide. An initial assessment can be done by looking at the documentation. After the replay is attempted, it is possible that the documentation may be found to be incorrect. If this is the case, further work on the replay validation should be postponed until correct documentation can be obtained.

4.3 **General Notes**

Several readout facilities have commented that their 'customers' have erroneously assumed that the presentation/delivery of a readout report implies that the overall FDR system is serviceable, even when the content of the report is incomplete or implies that there may be faults within the system.

This misunderstanding has resulted in FDR system faults remaining unresolved. Appropriate validation of the initial data provided, together with a clear statement of the limitations of the readout report will help to minimise the chance of such dormant faults remaining undetected.

The following guidelines may assist in establishing a better understanding between the replay organisation and its customers:

- a) A replay organisation should have sufficient information about the aircraft and its modification status to enable them to make an accurate replay;
- b) Unless the replay organisation has sufficient information to determine the representative flight details for the recording, no attempt should be made to determine whether or not parameters are functioning correctly;
- c) If any parameters are 'no shows' or have unusual characteristics this should be noted on the report. The replay organisation should not attempt to extrapolate additional information regarding the functionality of parameters (i.e. they should not attempt to derive information that is not directly available from the data obtained from the flight data recorder). The operator or recipient of the report has responsibility for investigating any reported anomalies. That said, if a replay organisation has sufficient experience to suggest possible meanings for the data, they can provide additional commentary to support the validation report as long as the report makes it clear that the final responsibility lies with the operator;
- d) The operator should ensure that an assessment is conducted to confirm that the quantity and quality of all data recovered from the FDR is correct for the data rate of the system and the recorder part number concerned.

5 **Establishing Revision and Applicability of DFLs and Conversion Data**

5.1 **Responsibility**

It is the responsibility of the operator to provide, along with their work request, the details of the appropriate DFL and conversion data provided as part of the TC/STC and C of A processes – see paragraphs 6.1 and 6.2 together with their current revision status.

5.2 **Purpose**

The purpose of defining the revision status and applicability of Data Frame Layouts (DFLs) and Conversion data prior to replaying a recorder is to ensure that the appropriate and up-to-date information is used during the replay process.

5.3 **General Notes**

None.

6 Replaying the FDR Recorded Data

6.1 Responsibility

This is the responsibility of the organisation performing the readout.

6.2 Purpose

The purpose of replaying the FDR is to generate a report on the FDR's content for subsequent review and validation.

6.3 General Notes

The organisation responsible for performing the readout will ensure that it is carried out using the appropriate approved decoding data and equipment recommended for the process (see also Chapter 8, paragraph 2.3).

In the event that more technologically advanced equipment becomes available, the means of complying with this should be justified as being equivalent and suitable and should involve the approval of the relevant equipment/aircraft manufacturer.

7 Reporting the FDR Readout Results

7.1 Responsibility

This is the responsibility of the replay organisation responsible for performing the readout.

7.2 Purpose

The purpose of generating a readout report is to provide the customer with documented evidence of the content of their recorder, together with any anomalies the replay organisation has identified.

7.3 General Notes

There is no pre-defined layout or format for FDR readout reports but the following information should be provided as a minimum:

- a) Unique Document Identifier for the Readout Report;
- b) Aircraft Registration;
- c) Aircraft Serial Number;
- d) FDR Part Number;
- e) FDR Serial Number;
- f) Data Acquisition Unit Details;
- g) Date of Replay;
- h) Issue/Vsn and Reference of Data Frame Layout Document;
- i) Issue/Vsn and Reference of Other Associated Documents (e.g. Information to Convert to Engineering Units);
- j) Supplier of DFL and Associated Information;
- k) Parameters Replayed;
- l) 'No Shows';
- m) Noted Anomalies;

- n) Compliance with General FDR Requirements, e.g. Sampling Rates;
- o) How to Interpret Report (i.e. 'This report is solely documenting the outcome of the replay. The operator is responsible for the assessment of these results and determination that the FDR system is functioning correctly');
- p) Download Validation Equipment used – part number/vsn no. etc.

8 Assessment of the FDR Readout Results

8.1 Responsibility

This is the responsibility of the aircraft operator/owner.

8.2 Purpose

The purpose of this assessment is to determine the actual serviceability of the FDR system and to assist in the scheduling of any necessary maintenance work.

8.3 General Notes

The aircraft operator/owner must carefully analyse the FDR readout to establish whether it contains any anomalies. If anomalies are found, the aircraft operator/owner must investigate them to determine their cause.

Where an operator is to contract this task this should be detailed in the CAME or Engineering Manual and a contract established with the delegated organisation. The operator, however, remains responsible for ensuring this task is carried out.

A more detailed explanation is given in Appendix C.

Where the readout includes data of a representative flight a check for the reasonableness of recorded data against the representative flight profile should be carried out.

Anomalies may relate to any of the following:

- a) Mandatory Parameters;
- b) FDM Parameters;
- c) Non-Mandatory Parameters.

Where an operator is running an approved FDM programme, the supporting documentation should be updated to include the FDM parameters.

NOTE: This is only intended to ensure that the FDM parameters can be accurately analysed, it is not to be confused with the requirements for the FDR mandatory parameter list (e.g. EU-OPS 1, JAR-OPS 3 and xx.1459 – where xx refers to the relevant CS/JAR document, i.e. 23, 25 etc.)

If an anomaly relates to one or more mandatory parameters the necessary rectification work must be performed within the time period specified by the relevant MMEL or operational rule. In addition, the aircraft operator/owner should organise for a further replay immediately the rectification work is complete. Alternatively, if the defect can be positively identified and rectification established via ground testing, then no further download is required.

Where an MEL allowance is required, the MEL rectification interval starts when the FDR parameter(s) defects are identified.

In the scope of this document, the MEL allowances refer only to unserviceable FDRs or FDR parameters. If the equipment that parameters are derived from is faulty, that equipment is subject to its own MEL restrictions.

All proposed FDR maintenance programmes, particularly related to mandatory parameters, require approval by the CAA.

NOTE: Whilst it is not intended to exceed the FDM guidance provided in CAP 739 in terms of parameter maintenance, the CAA considers that it would be beneficial for operators to ensure that parameters used by their FDM programmes remain serviceable.

9 Retention and Control of FDR Readout Results

9.1 Responsibility

This is the responsibility of the FDR readout facility and the aircraft operator/owner.

- a) The operator/owner is required to retain the record of a representative flight conducted during the previous twelve months.
- b) The readout facility is required to retain readout records/test reports in a manner and for a period acceptable to the CAA.

9.2 Purpose

The purpose of this is to ensure that both the aircraft operator/owner AND the replay house can accurately determine the currently recorded status of the FDR system.

9.3 General Notes

The record(s) must be retained in a safe manner and correctly identified to the aircraft and the flight to which it pertains.

INTENTIONALLY LEFT BLANK

Chapter 8 General Requirements for a Readout/Replay Facility

1 Introduction

Applicants seeking EASA Part 145 approval for FDR Readouts/CVR Replays will need to take the following information into consideration for approval to be granted and specified in the Maintenance Organisation Exposition (MOE). These include:

- a) Procedures specific to the readout of FDRs/CVR replays;
- b) Provision and control of associated replay support documentation;
- c) Staff Training and Competence;
- d) Procedures specific to the certification of FDR Readout(s)/CVR Replays (refer to Chapter 9).

NOTES: 1 An operator which has contracted this task must detail in their CAME who carries out the readout and how they control and audit them.

2 Where the term readout is used, this also includes CVR Replay.

2 Required Procedures

2.1 Procedures for Replay Support Documentation

These procedures should cover the provision and configuration control of the documents and the means used to correlate specific documents to specific aircraft and flight recorders.

The same procedures should be applied to any other supporting data necessary for an FDR readout. As a minimum, the documents covered by these procedures should include the following:

- a) Data Frame Layout Documents;
- b) Engineering Conversion Documents.

2.2 Procedures for Assessing Aircraft/Flight Information

All readout facilities should have procedures in place to assist when assessing the level of aircraft/flight information provided by the customer to determine whether it is possible to provide an accurate and useable readout.

The procedures should cover:

- a) checks for the existence of basic information;
- b) checks for assessing the information provided relating to the sample flight, to determine what data can or cannot be gathered on individual parameters (i.e. if flight altitude data is not provided the altitude parameter cannot be validated);
- c) the way in which this data should be assessed to make a determination of the possible FDR readout report detail (i.e. is there sufficient information to validate the accuracy of the parameters or is it only possible to determine 'shows' and 'no-shows'?);
- d) the generation of the 'Report Limitations' section of the FDR report;
- e) the formal agreement of those limitations with the operator/aircraft owner.

2.3 **Procedures for the Use of Replay Equipment**

All replay facilities should have procedures in place detailing the required means of operating the replay equipment.

The procedures should cover:

- a) how to establish that the correct replay equipment is being used;
- b) how to connect the replay equipment;
- c) how to operate the replay equipment;
- d) how to detect replay equipment failures.

2.4 **Procedures for Revision Control and Storage of Replay Documents**

All replay facilities should have procedures in place covering the revision control of all FDR replay documents, including regulatory, technical and background documents.

The procedures should cover:

- a) a list of all documents to be configured;
- b) a list of the different types of media being used (e.g. CD, Magnetic Tape etc.);
- c) the method of configuration control being used;
- d) the means used to store them (including any environmental considerations);
- e) the location of all configured documents;
- f) the means of accessing those documents;
- g) the backup procedures;
- h) the procedures for off-site duplicates (to avoid fire/flood damage);
- i) full software and hardware descriptions and control of past versions etc;
- j) security and control of access to FDR data.

2.5 **Procedures for Staff Training**

All replay facilities should have procedures in place to address the issue of staff training.

The procedures should cover:

- a) The basic knowledge required to replay FDRs. As a minimum this should include:
 - i) understanding of FDR hardware design, maintenance and replay;
 - ii) assessing the accuracy/currency of the associated DFLs etc;
 - iii) assessing the aircraft information provided;
 - iv) software design;
- b) the interpretation of:
 - i) the ANO;
 - ii) EU-OPS 1
 - iii) JAR-OPS 3;
 - iv) ED-55, ED 112;
 - v) CAA Spec 10;
 - vi) CAA Spec 10A;

- vii) CAA Spec 11;
- viii) CAA Spec 18;
- c) using the necessary tools;
- d) interpreting the output of those tools;
- e) drafting replay reports;
- f) the required update training (e.g. new recorders);
- g) the means of staff training;
- h) the method of keeping and updating staff training records.

2.6 **Control of Tools and Equipment**

All replay facilities should have procedures in place to address the issues related to control of the tools and equipment used for replaying flight data recorders.

The procedures should cover:

- a) the considerations related to determining the need for new tools/equipment;
- b) the issues to consider when buying new tools/equipment;
- c) assessing proposed updates for current tools/equipment;
- d) maintaining/calibrating any tools used for replaying flight data recorders;
- e) the processes for backing up any necessary files.

3 **Control of DFLs**

3.1 **Sources of DFLs**

It is the responsibility of the operator/owner to provide or confirm the appropriate issue and revision status of the DFL and conversion data.

3.2 **Determining Status of DFLs**

Before using a DFL for FDR replay purposes, a replay organisation must ensure that they have the most up-to-date issue of the DFL for the aircraft in question.

The issues to consider include:

- a) the currency of the proposed DFL;
- b) the applicability of the DFL for the aircraft in question.

3.3 **Document Control of DFLs and Other Related Records**

All replay facilities should have a set of document control processes for the DFLs (and any other related documents) they hold.

The processes should include:

- a) Configuration Control. These should include:
 - i) controls for access to the documents (to ensure they do not get lost);
 - ii) version control (to ensure that all relevant versions are held in known locations) and means to enable the relevant versions to be determined;
 - iii) controls for internal document updates (i.e. what update was made, who made the update and when);
 - iv) control of the deletion/removal of documents to ensure they are not deleted/removed before the end of their useful life;

- b) Means of Storage. These should include:
 - i) the media the data is stored on (e.g. paper, CD-ROM etc.);
 - ii) the necessary protection for that data (e.g. fire-, water- and EM- proof stores);
 - iii) any off-site duplicates in case of fire, flood, theft or structural damage;
- c) Control of Customer Records. These should include:
 - i) a list of what records are stored for each customer;
 - ii) the details of where those records are stored.

4 Staff Competence

All replay facilities are expected to have a sufficient number of staff with the appropriate levels of experience to perform flight data recorder replays with an acceptable level of accuracy.

5 Additional Requirements for CVR Replay Facility

- 5.1 For CVR replay, a quiet secure area should be provided, to both ensure privacy and to enable recording quality to be assessed.

Chapter 9 Release Certification of Readouts

The type of release certification required for the readout will depend on the purpose for which the readout is being used.

- 1 If the purpose of the readout is to comply with the ANO 2009 articles 153, 154 and 155 requirements, this is not classified as maintenance and therefore the issue of an EASA Form 1 is not required. However, it is expected that the integrity of the data is validated prior to being placed on record.
- 2 If the purpose of the readout is to confirm the correct presence of a discrete, the accuracy of a sensor, or comply with a maintenance programme requirement to verify that parameters are being accurately recorded, the issue of an EASA Form 1 may be appropriate. However, this will depend on the information supplied to the readout facility that allows them to determine the accuracy of the downloaded data (refer to Chapter 7).
- 3 If the readout facility is not provided with sufficient information by the operator or his assigned maintenance organisation to enable them to determine the accuracy of the recorded data they cannot issue an EASA Form 1.
- 4 If the readout facility is provided with sufficient information by the operator or his assigned maintenance organisation and the accuracy of the recorded data is confirmed to be within the specified tolerances, the issue of an EASA Form 1 is appropriate. In this case the wording on the EASA Form 1 should be as follows:

Box 11: annotated "*Inspected*"

Box 12: "*Certified that the flight data transcription has been carried out in accordance with the requirements of the Civil Aviation Authority relating to the supply of flight data information. Data held by this organisation, and in accordance with EASA Part 145.A.45 (b), has been used to prepare the FDR readout and is referenced as xxxxxxxx (insert applicable data references, DFL etc.)*".

NOTE 1: Work orders from operators must clearly specify the purpose of the readout and what certification is required, taking into consideration paragraphs 1 and 2 above.

NOTE 2: Due to the number of parameters recorded by modern DFDR systems, certification on an EASA Form 1 only relates to the serviceability of parameters classified as mandatory by the relevant operational rule.

NOTE 3: For EASA Form 1 box numbers refer to Commission Regulation (EC) 2042/2003 as amended.

INTENTIONALLY LEFT BLANK

Chapter 10 General Guidance on FDM

1 General

The United Kingdom Civil Aviation Authority's Flight Operations Policy Department and Strategic Safety and Analysis have developed and published CAP 739 'Flight Data Monitoring A Guide to Good Practice'.

For further information on this subject please refer to CAP 739.

INTENTIONALLY LEFT BLANK

Chapter 11 Timescales

ANO 2009 Articles 153, 154 and 155 (as amended) require that operators preserve a record of one representative flight made within the last 12 months. Following this flight, validation of the recorded data should be carried out to ensure that the data corresponds with the representative flight profile.

Therefore no readout validation should exceed a period of 12 months from the date of the last validation.

Where a validation has taken place and evidence has shown certain parameters to be faulty, these are required to be addressed within the timeframe given in the Approved Minimum Equipment List.

INTENTIONALLY LEFT BLANK

Chapter 12 Cockpit Voice Recorders (CVR)

Maintenance and Continued Airworthiness

This Chapter deals with the ongoing maintenance and continued airworthiness requirements for Cockpit Voice Recorders.

The European Organization for Civil Aviation Equipment (EUROCAE) has developed ED-112, the most recent industry standard for FDR and CVR. In addition, ICAO has also published information in Annex 6 that provides guidance in order to detect dormant failures in both Flight Data Recorder (FDR) and Cockpit Voice Recorder (CVR) systems. Annex 6, part I, attachment D relates to international commercial air transport – aeroplanes, Annex 6, part II, attachment 3C relates to international general aviation – aeroplanes and Annex 6, part 3, attachment B relates to international operations – helicopters.

In December 2009 EASA published Service Information Bulletin (SIB) 2009-28 to highlight to owners and operators the minimum maintenance recommendations for both CVR and FDR systems.

CAA Specification 11 previously dealt with in some measure the ongoing maintenance requirements of CVR systems. This document is still available on the CAA website, however in the light of ongoing changes to ICAO and EASA recommendations the following paragraphs should be the first point of reference.

1 CAA Recommendations

1.1 The CAA recommends the following for continued airworthiness of Cockpit Voice Recorders.

a) At intervals not exceeding 6 months

- i) In the first instance the Type Certificate (TC) or Supplemental Type Certificate (STC) Holder's Recommendations should be followed. If these recommendations are not as comprehensive as detailed in paragraph ii) that paragraph should be carried out as a minimum.
- ii) In the absence of specific instructions from the TC/STC holder inspect the installation. Whenever the following functions are available, confirm by means of the CVR controller monitor jack, proper recording on each audio channel from area microphone(s), receiver audio, sidetone, interphone, public address (if recorded) and boom microphone (including 'hot mike' function, i.e. interphone OFF). Confirm proper function of the inhibit logic for the bulk erase.

b) At intervals not exceeding 12 months for Tape Based CVRs and at C of A issue for Solid State CVRs

- i) An examination of the recorded signal on the CVR should be carried out by replay of the CVR recording. While installed in the aircraft, the CVR should record test signals from each aircraft source and from relevant external sources to ensure that all required signals meet intelligibility standards; and where practicable, during the annual examination, a sample of in-flight recordings of the CVR should be examined for evidence that the intelligibility of the signal is acceptable. An example of a Tape Based CVR is the L3 (Fairchild) A100 type.

Further guidance is in CAA specification 11.

Operators should review all their Approved Aircraft Maintenance Programmes for compliance with the above recommendations. If changes are needed these should be submitted to the CAA for review and approval.

c) Example Replay and Analysis

The replay centre should establish that recordings of adequate quality have been made on all channels for the test conditions stated below. In addition to subjective listening tests, proper signal recording level should be confirmed.

The recording should be played back in an area where the privacy and confidentiality of the recorded voices may be assured. This may require a separate room depending on the size of the organisation performing the task.

To assess the serviceability of the CVR system the Type Certificate holder's data should be used, however, the following checks and functional tests are given as an example:

- i) All voice communications transmitted from or received by the aircraft communications equipment;
- ii) All conversation on the flight deck;
- iii) Voice communications of flight crew-members on the flight deck, using the aircraft's interphone system;
- iv) Voice or audio signals identifying navigation aids introduced into the aircraft audio system;
- v) Audio signals from alerting or warning devices on the flight deck, both fully integrated with the aircraft audio system and non integrated;
- vi) General flight deck sounds, monitor the Cockpit Area Microphone to ensure that it satisfactorily picks up all cockpit sounds.

d) Operators Responsibilities

Where an operator undertakes to carry out validation of their own CVR Replays this should be detailed in the company CAME. This replay will be undertaken by competent staff and will be documented.

A procedure should be established, acceptable to the CAA, which enables the operator to demonstrate that a replay has been carried out, which should highlight any deficiencies and the associated remedial actions.

The operator may sub-contract this task to an unapproved organisation and detail this in the CAME. However, this task will still form part of the operator's EASA Part M Sub-part G approval.

The Civil Aviation Authority recognises that in certain cases an aircraft operator may lack sufficient resources to undertake CVR Replay. In these cases the replay, as detailed in the subject procedure, may be contracted to a third party by the operator. In these circumstances the operator will need to provide evidence of the following:

- The EASA Part 145 organisation has the capability to replay CVRs in their approved procedures.
- The EASA Part 145 CVR replay report should include an assessment in accordance with these procedures.

The report should identify the aircraft and flight concerned and should confirm that all input channels were identified for the various test conditions. Details of any other observations made from the recording should be included. For helicopters, correlation between rotor speed announcements by the crew and recorded rotor speed data should be established and recorded. In all cases, the position of the area microphone in the particular aircraft should be stated in the report.

e) **Preservation of Recording**

Under certain conditions the CVR may continue run and record while electrical power is provided to the recorder. Evidence from the AAIB confirms that even if the Flight Crew has isolated electrical power to the CVR, subsequent maintenance or other activity may have re-instated the power supply resulting in the loss of the recording.

Regulations at the date of publication, requiring the preservation of recordings are as follows:

ICAO Annex 6 Part I, 11.6 requires that "An operator shall ensure, to the extent possible, in the event an aeroplane becomes involved in a accident or incident, the preservation of all related flight recorder records and, if necessary, the associated flight recorders, and their retention in safe custody pending their disposition as determined in accordance with annex 13."

EU-OPS 1.160 requires that:

- "1/ Following an accident, the operator of an aeroplane on which a flight recorder is carried shall, to the extent possible, preserve the original recorded data pertaining to that accident, as retained by the recorder for a period of 60 days unless otherwise directed by the investigating authority.*
- 2/ Unless prior permission has been granted by the Authority, following an incident that is subject to mandatory reporting, the operator of an aeroplane on which a flight recorder is carried shall, to the extent possible, preserve the original recorded data pertaining to that incident, as retained by the recorder for a period of 60 days unless otherwise directed by the investigating authority."*

Operators and continuing airworthiness management organisations should ensure that robust procedures are in place and prescribed in the relevant Operations Manual and Expositions to ensure that CVR/FDR recordings that may assist in the investigation of an accident or incident are appropriately preserved. This should include raising awareness of Flight Crew and Maintenance staff to minimise the possibility of loss of any recorded data on both the CVR and FDR.

When appropriate, the relevant circuit breakers should be pulled and collared/ tagged and an entry made in the aircraft technical log to make clear to any airline personnel that an investigation is progressing. Furthermore, confirmation from the investigating authority/operator is required to be obtained before systems are reactivated and power is restored.

Operators who contract their maintenance activities or ground handling to a third party should ensure that the contracted organisation is made aware of all their relevant procedures.

INTENTIONALLY LEFT BLANK

Appendix A Flight Data Recorder Compliance Document

Table 1

Aircraft Type:	Registration:
FDR Make and Model:	CAA/JAA Approval ref:
Installed in accordance with: *	FDR Maintenance Programme ref: ♦
Data Frame Document ref:	Revision:
Conversion Data Document ref:	Revision:
Date of readout:	Test report ref:

The flight data recorder installation in this aircraft has been installed in accordance with the current requirements for the type. An assessment of the test report and a check against the flight profile has been carried out to verify correct operation.

Signed:

Operator:

Date:

* ANO 2009 Schedule 4; EU-OPS paragraphs 1.715, 1.720, 1.725; JAR-OPS paragraphs 3.715 and 3.720; CAA Spec 10/10A and 18; and EUROCAE Doc ED-55 as applicable.

♦ EUROCAE Doc ED-55 paragraph 2.16 and Annex 4; CAA Spec 10A; FDR maintenance requirements included in the aircraft Maintenance Schedule.

INTENTIONALLY LEFT BLANK

Appendix B Example FDR Replay Support Documents

1 Introduction to Data Frames

A Flight Data Acquisition Unit (FDAU) takes the aircraft inputs and condenses the data into a multiplexed digital data stream for recording onto the Digital Flight Data Recorder (DFDR).

When the data is extracted, the process has to be reversed and the raw binary data has to be converted back into engineering units.

This decoding process has two phases. The first is to know which data bits correspond to which variable parameters as defined by the dataframe layout and the second is to know the scaling factor that will convert the binary value for a given parameter back to the original engineering value. The dataframe definition defines the bit map and scaling laws that allow conversion between raw binary and engineering units.

The number of bits that a parameter occupies determines the number of states that a given parameter can have. Thus, a parameter stored in 12 bits can have 4,096 possible states (range of 0 to 4,095 counts, see Table 2). The resolution is the range of the parameter, divided by the number of possible states and is hence the bit weighting of the least significant bit used. Note that the recorded range is always larger than the range encountered in service in order to accommodate the actual and out of range inputs. Some ranges will be signed, such as roll angle or outside air temperature. Some ranges will be positive only, such as airspeed or magnetic heading.

A parameter's sample rate is the number of recordings made by the DFDR within a given period of time, usually per second. Some parameters, such as vertical acceleration, are recorded several times a second, while others, such as date, are recorded at a very slow rate, e.g. once per 16 seconds. Each parameter's minimum sample rate in the DFDR is determined by the regulations, and should be distinguished from the rate at which the parameter is refreshed on the DFDAU input bus. Thus, whilst the gross weight may be refreshed every 20 milliseconds at the DFDAU 429 input port, it will only be recorded every 64 seconds on the DFDR. It is important that the Databus refresh rate is consistent with the required data capture rate.

2 What is a Data Frame?

The previous section introduced the notion of a data frame that contains bit mapping and scaling information. The FDR system dataframe will normally comprise of multiples of 64_D words recorded every second, e.g. 64, 128, 256, 512 or 1,024 words per second. This number is used due to the original encoding of the word number counter using three bit octal counters and 64_D being equivalent to the maximum available using the two least significant bits of this counter = 77_O . For the purposes of this section, a data rate of 64 wps is used, and at 12 bits/word, this corresponds to a bit rate of 768 bits/sec.

3 Data Frame Structure

An FDR dataframe occupies a 4 second interval, within which are four 1 second subframes, called subframes 1, 2, 3 and 4. These subframes appear in sequential order, over and over again in the data as the subframe pattern repeats for each new data frame.

The ARINC Characteristic 573 (Mark 2 Aircraft Integrated Data System) data frame concept developed at the point when tape damage due to crash loads was a concern. ARINC defined a set of synchronisation words (sync words), one for each subframe, that would be located into the first word of each subframe. This sync pattern was clarified in ARINC Characteristic 717 (Digital Flight Data Acquisition Unit), removing the ambiguity in ARINC 573 concerning the direction that the bit pattern should be read.

In good flight data, once the sync word for subframe 1 has been found, moving 64 words further into the data will find the sync word for subframe 2, and so on until subframe 1 is reached in the next frame. A block of data that has all the right sync words in all the right places is synchronised. Any unsynchronised data should be treated with caution.

Once the sync word pattern has been restored, the data integrity in terms of data location should also have been restored.

Most data frames contain a frame counter to help track possible gaps in the data. This frame counter is usually a full word (12 bits), and can have 4,096 possible states (0 to 4095) which the data frame steps through, until the frame counter gets to 4,095 and the process begins again. This counter is generated by the DFDAU.

However, the readout software may put a frame number on each sequential group of four subframes. Thus, if there are 20,000 frames in a block of data, the frame number will run from 1 to 20,000, in order. This frame number applied to the data by the readout software is not contained within the data itself, and does not repeat as part of a cycle.

Other than the sync words and a possible frame counter, all other words in the data frame can be filled with any combination of numeric parameters and discretises. Each subframe is defined separately, so that different subframes can record quite different data, if so desired.

Each four second 64 wps data frame can generate 252 12 bit words (256 available, minus the 4 sync words), or 3,024 bits that are available to record data. The number of parameters that can be stored depends on the range and resolution of each parameter (number of bits) and the sample rate (how often a parameter is recorded) required. For DFDR data frames, range, resolution and sample rates are set by the regulations for all mandatory parameters.

Resolution is the smallest change in a parameter value that can be recorded. This depends on the number of bits allocated to that parameter, and the value range that the DFDR can accommodate.

For example, oil temperature may vary from 0°C to 300°C. To be sure to cover the operational range, the recorded range is 0° to 400° C.

If oil temperature is stored in a 12 bit word with 4,096 possible states, then the resolution is:

$$\begin{aligned}\text{Resolution} &= \text{range}/\text{range of recorded digital word} \\ 400^\circ\text{C range}/4,095 \text{ bits} &= 0.09768^\circ\text{C/bit}\end{aligned}$$

In some cases, the regulations may require a resolution that a single 12 bit word cannot provide. In this case, it will probably be necessary to store such a parameter in two data frame words, with a fine and coarse component. Examples of parameters that may require more than 12 bits to meet the range and resolution requirements are altitude, latitude and longitude.

The sample rate needed for a given parameter can vary widely. For example, "month" changes rarely during a flight, and can be recorded with a long interval. Vertical acceleration (Nz) is typically recorded at eight times per second to capture the parameter with sufficient precision. A parameter stored in the same word in each subframe has a sample rate of once per second. Nz requires eight words per data frame, and these must be spread evenly through the 64 available words, for a sample rate of once every 0.125 seconds and a total of 32 total words in the four second data frame.

As data frames developed, designers found that they had more parameters to record than there were words to store them. To increase the possibilities available the superframe was defined. In this concept, the same word in the frame has a 16 count cycle where different parameters may be stored. When the 16th step is reached, the next word goes back to the first step and starts over again. If superframes are used, a superframe counter also has to be stored. The superframe counter determines the recording position within the 16 step sequence.

Starting with the assumption that a data frame has been defined with a superframe word only in subframe 1, the following would be true:

If a parameter is recorded in only one of the 16 slots, the refresh rate will be (subframe 1 every 4 seconds) x (16 states per superframe cycle) = a 64 second sample rate. If the same superframe word is placed in all four subframes, the refresh rate becomes 16 seconds. Obviously, a superframe is only used for those parameters which change slowly. Typical superframe parameters may include gross weight, day/month/year, and flight number.

Some parameters, such as airspeed, are numeric. That is, they have a numeric value, such as 325 knots. Other parameters, called discretets, are a coded way to describe the aircraft configuration or system configuration.

A discrete is a parameter that can have only two defined states. A discrete will have a value of one or zero, such as gear up/down or master caution ON/OFF.

However, a number of discretets may be used together to represent a combination of values and require tables to define the recorded bit patterns. In this way, n discretets can provide 2^n combinations. For example, four discretets could be combined to represent sixteen autopilot modes.

NOTE: This coding normally takes place within the aircraft system LRUs, e.g. autopilot, and is not normally a function performed by the FDR system LRU (FDAU), that purely sample and store the input data within a serial dataframe for recording on the FDR. However, this coding process must be determined to permit accurate re-conversion of the recorded data into engineering terms.

4 Data Conversions

The range and resolution with which the data word can store numeric values depends on the number of bits that the data frame assigns to that parameter. If a parameter occupies all 12 bits, there can be 4,096 different values covering the range of the engineering parameter. Table 2 shows the number of states possible for different numbers of bits. The resolution of the storage process is one bit divided by the total

number of possible states. Thus, a 12 bit word has a resolution of 1/4,095 of the full range of the engineering parameter being represented.

Shown below, the data word has a maximum range of 8,190 with a resolution of 2.

Table 1 Powers of 2 (Bit Resolution)

Number of Bit	12 MSB	11	10	9	8	7	6	5	4	3	2	1 LSB
Bit Weighting	4,096	2,048	1,024	512	256	128	64	32	16	8	4	2

NOTE: MSB=Most Significant Bit LSB=Least Significant Bit

There are two basic kinds of data to be stored; data from an analogue source (synchro, AC or DC voltage ratio, variable resistance, potentiometer, High Level DC, Low Level DC or Very Low Level DC) or a digital source such as an ARINC 429 bus. The conversion to and from the 12 bit word value is different for the two kinds of data.

To describe the process of converting digital data into the FDR system data format, let us assume an altitude value is being sent to the FDR system 12 bit word on an ARINC 429 bus input. Let the altitude range between 0 and 65,535 ft, where 65,536 is the number of possible states for an input that occupies 16 bits. Thus, the parameter range is from 0 to 65,535 with a resolution of 1 ft. To be recorded within one FDR system data word, this needs to be mapped into a 12 bit parameter with 4,096 different states. Therefore, for an altitude value of 10,000 ft:

$$\begin{aligned} \text{Digital counts, 12 bits} &= 4,095 * (10,000 \text{ ft data}/65,536 \text{ full range}) \\ &= 625 \text{ counts (decimal), or } 1,161 \text{ counts (octal)} \end{aligned}$$

$$\begin{aligned} \text{Resolution, 12 bits} &= 65,536 \text{ ft full range}/4095 \text{ counts full range in 12 bits)} \\ &= 16 \text{ ft} \\ &= \text{The equivalent of 4 bits resolution when 16 bits map into 12} \\ &= 16 \text{ ft/count} * 4,096 \text{ counts possible} = 65,536 \text{ (0 to 65,535 ft)} \end{aligned}$$

Once the resolution is established, this can be used to recalculate the actual count value using the actual range achievable with the 12 recorded bits, i.e. maximum range is not 65,536 but is 65,520 due to the 16 foot recorded resolution.

Therefore:

$$\begin{aligned} \text{Digital counts, 12 bits} &= 4,095 * (10,000 \text{ ft data}/65,520 \text{ full range}) \\ &= 625 \text{ counts (decimal), or } 1,161 \text{ counts (octal)}. \end{aligned}$$

For the next example, assume a signed altitude (plus and minus values possible) is being stored. Thus, in the 16 bit word, one bit is the sign, which leaves 15 bits (32,768 possible states) plus the sign bit to give an overall range of 65,536 states split evenly over the +/- 32,767 ft range. In order to accommodate the +/- range in the recorded data word, the input value is converted into an offset binary value such that a zero input equates to half range recorded counts. This offset is then subtracted during the data re-conversion process, using a "c" in a $y = mx+c$ format.

To calculate the digital counts for a one foot accuracy (+/- 32,767 ft):

$$\begin{aligned} \text{Digital counts, 12 bits} &= 4,095 * (10,000 \text{ ft} - (-32,768 \text{ ft at 0 counts}))/65,536 \text{ ft} \\ &= 4,095 * 42,768/65,536 \\ &= 2,672 \text{ decimal or } 5,160 \text{ octal counts} \\ &\text{where } 2,048 \text{ counts decimal is approximately zero altitude.} \end{aligned}$$

$$\begin{aligned} \text{Resolution} &= (+32,736 \text{ to } -32,736 \text{ range})/4,096 \text{ states in 12 bits} \\ &= 16 \text{ ft} \end{aligned}$$

Once the resolution is established, this can be used to recalculate the actual count value using the actual range achievable with the 12 recorded bits, i.e. maximum range is not 65,536 but is 65,520 due to the 16 ft recorded resolution.

Therefore:

$$\begin{aligned}\text{Digital counts, 12 bits} &= 4,095 * (10,000 \text{ ft} - (-32,752 \text{ ft at 0 counts}))/65,520 \text{ ft} \\ &= 4,095 * 42,752/65,520 \\ &= 2,672 \text{ decimal or } 5,160 \text{ octal counts.}\end{aligned}$$

Analogue data works somewhat differently, with one exception. Synchro inputs can be treated like digital data, where the full range of 0 to 360° (inclusive) can be encoded directly into the full range of a data word such that a full range count of 4,095 = 359.9° and 4,096 counts = 360° = 0 counts = 0°, because it is possible to cross over zero degrees and continue, like a compass reading.

In order to convert into engineering units, it is then necessary to apply the signal source LRU's data conversion factor as a part of, or after, this conversion process.

Other analogue source data will use a count to input range specified for each input, normally in accordance with ARINC 573. For example, a Low Level DC (LLDC) input will be accepted with an input range of 0 to 5Vdc with 0V being recorded as 0 counts and 5V as 4,095 counts (assuming a 12 bit word).

Thus any conversion from the recorded data will identify the input voltage that then must be reconverted to raw source (engineering unit) data using the signal source LRU's data.

For example:

Normal Acceleration (Nz) is recorded as a 12 bit word with 4,096 states. The total range of the input is -3.375g to +6.0g, giving an input range of 9.375g. As this is a bipolar input (+ and - ranges), the data is handled as an offset bipolar word with a -3.375g offset.

Therefore, for a Nz of 2.0g;

$$\begin{aligned}\text{Digital counts, 12 bits} &= 4,095 * (2g + 3.375g)/9.375g \\ &= 2,348 \text{ decimal or } 4,454 \text{ octal counts}\end{aligned}$$

$$\begin{aligned}\text{Resolution, 12 bits} &= \text{total input range (gravities)/total range (counts)} \\ &= 9.375g/4,096 \text{ (0 to 4,095 counts used)} \\ &= 0.002289 \text{ g/bit.}\end{aligned}$$

NOTE: In this case, a value of "4,096" is used in the calculation because the input range is -3.375 to +6.0g and thus 0 counts = -3.375g, an actual value and is thus considered as an "inclusive" range.

If the range had been 0 to 6.0g, 0 counts would equate to 0g with no offset, so any value would have been equated using the value 4,095 as this is considered an "exclusive" range.

NOTE: The following data in this Appendix are examples of, and extracts from, typical FDR replay support documents. They are for illustrative purposes only.

4.1 Example Data Frame Layout Document

Table 2 Data Frame Format - Analogue Frame

WD	PARAMETER	WD	PARAMETER	WD	PARAMETER	WD	PARAMETER	WD	PARAMETER	WD	PARAMETER	WD	PARAMETER	WD	PARAMETER	WD	PARAMETER																								
00 1	SYNCH WORDS	10	MAGNETIC HEADING	20	AFCS DISCRETES WORD A	30	AFCS WORD B	40	AFCS WORD C	50	DRIFT ANGLE	60	WARNING DISCRETES	70	SUPERFRAME 1																										
		9		25		33		41		49		57																													
		11		COMPUTED AIRSPEED		18		PITCH TRIM POS'N		31		RAD ALT #1		41		RAD ALT #2	51	GROUND SPEED	61	TCAS RESOLUTION ADVISORY	71	PRESSURE ALTITUDE FINE																			
																							10	34	42	58															
01 2	BRAKES LH GR BRAKES RH GR BRAKES LH YE BRAKES RH YE	12	LH ROLL SPOILER	19	PR ALT CRS	32	AIRBRAKE POS'N	42	ANGLE OF ATTACK	52	RH ROLL SPOILER	62	FRAME COUNT	72	AIRBRAKE POS'N																										
																11	ANGLE OF ATTACK	43	35	53	NORMAL ACCELERATION	63	NORMAL ACCELERATION	73	NORMAL ACCELERATION																
																										13	NORMAL ACCELERATION	23	LONGITUDINAL ACCELERATION	33	LATERAL ACCELERATION	43	RUDDER POS'N	53	LH AILERON POS'N	63	RH AILERON POS'N				
																																						14	21	29	38
02 3	ANGLE OF ATTACK	13	LH ROLL SPOILER	19	PR ALT CRS	32	AIRBRAKE POS'N	42	ANGLE OF ATTACK	52	RH ROLL SPOILER	62	FRAME COUNT	72	AIRBRAKE POS'N																										
																12	NORMAL ACCELERATION	22	PITCH ATTITUDE	32	LATERAL ACCELERATION	42	RUDDER POS'N	52	LONGITUDINAL ACCELERATION	62	LATERAL ACCELERATION	72	AIRBRAKE POS'N												
																														14	LONGITUDINAL ACCELERATION	24	PITCH ATTITUDE	34	LATERAL ACCELERATION	44	RUDDER POS'N	54	LONGITUDINAL ACCELERATION	64	LONGITUDINAL ACCELERATION
03 4	NORMAL ACCELERATION	13	NORMAL ACCELERATION	23	NORMAL ACCELERATION	33	NORMAL ACCELERATION	43	NORMAL ACCELERATION	53	NORMAL ACCELERATION	63	NORMAL ACCELERATION	73	NORMAL ACCELERATION																										
																14	LONGITUDINAL ACCELERATION	24	PITCH ATTITUDE	34	LATERAL ACCELERATION	44	RUDDER POS'N	54	LONGITUDINAL ACCELERATION	64	LONGITUDINAL ACCELERATION	74	LONGITUDINAL ACCELERATION												
																														15	LATERAL ACCELERATION	25	ROLL ATTITUDE	35	LATERAL ACCELERATION	45	RUDDER POS'N	55	LONGITUDINAL ACCELERATION	65	LONGITUDINAL ACCELERATION
04 5	LONGITUDINAL ACCELERATION	14	PITCH ATTITUDE	24	LONGITUDINAL ACCELERATION	34	LONGITUDINAL ACCELERATION	44	LONGITUDINAL ACCELERATION	54	PITCH ATTITUDE	64	LONGITUDINAL ACCELERATION	74	LONGITUDINAL ACCELERATION																										
																15	LATERAL ACCELERATION	25	LATERAL ACCELERATION	35	LATERAL ACCELERATION	45	RUDDER POS'N	55	LONGITUDINAL ACCELERATION	65	LONGITUDINAL ACCELERATION	75	RUDDER POS'N												
																														16	LH AILERON POS'N	26	RH ELEVATOR POS'N	36	RH AILERON POS'N	46	LH AILERON POS'N	56	LH AILERON POS'N	66	RH ELEVATOR POS'N
05 6	LATERAL ACCELERATION	15	ROLL ATTITUDE	25	LATERAL ACCELERATION	35	LATERAL ACCELERATION	45	LATERAL ACCELERATION	55	ROLL ATTITUDE	65	LATERAL ACCELERATION	75	RUDDER POS'N																										
																16	LH AILERON POS'N	26	RH ELEVATOR POS'N	36	RH AILERON POS'N	46	LH AILERON POS'N	56	LH AILERON POS'N	66	RH ELEVATOR POS'N	76	RH AILERON POS'N												
																														17	N1 ENGINE #1	27	THRUST TARGET	37	N1 ENGINE #2	47	N1 ENGINE #3	57	N1 ENGINE #4	67	N1 ENGINE #4
06 7	LH ELEVATOR POS'N	16	LH AILERON POS'N	26	RH ELEVATOR POS'N	36	RH AILERON POS'N	46	LH AILERON POS'N	56	LH AILERON POS'N	66	RH ELEVATOR POS'N	76	RH AILERON POS'N																										
																17	N1 ENGINE #1	27	THRUST TARGET	37	N1 ENGINE #2	47	N1 ENGINE #3	57	N1 ENGINE #4	67	N1 ENGINE #4	77	N1 ENGINE #4												
																														18	N1 ENGINE #1	28	THRUST TARGET	38	N1 ENGINE #2	48	N1 ENGINE #3	58	N1 ENGINE #4	68	N1 ENGINE #4
07 8	PLA ENG #1	17	N1 ENGINE #1	27	THRUST TARGET	37	N1 ENGINE #2	47	N1 ENGINE #3	57	N1 ENGINE #4	67	N1 ENGINE #4	77	N1 ENGINE #4																										
																18	N1 ENGINE #1	28	THRUST TARGET	38	N1 ENGINE #2	48	N1 ENGINE #3	58	N1 ENGINE #4	68	N1 ENGINE #4	78	N1 ENGINE #4												
																														19	N1 ENGINE #1	29	THRUST TARGET	39	N1 ENGINE #2	49	N1 ENGINE #3	59	N1 ENGINE #4	69	N1 ENGINE #4

Table 4 Data Frame format - Discrete Words and Superframes

	AFCS WORD A	AFCS WORD B	AFCS WORD C
BIT	SIGNAL	SIGNAL	SIGNAL
12 (MSB)	A/T ENG STATUS – 1	LAT ENG MODE – 1	A/T ENG MODE – 1
11	A/T ENG STATUS – 2	LAT ENG MODE – 2	A/T ENG MODE – 2
10	AP FD STATUS – 1	LAT ENG MODE – 3	A/T ENG MODE – 3
9	AP FD STATUS – 2	LAT ENG MODE – 4	A/T ENG MODE – 4
8	FLAP TRIM ENGAGE	VERT ENG MODE – 1	A/T ENG MODE – 5
7	AUTO TRIM ENGAGE	VERT ENG MODE – 2	THRUST AUTO ON
6	ELEC TRIM ENGAGE	VERT ENG MODE – 3	N1 COMPENSATE
5	YAW DAMPER ENGAGED #1	VERT ENG MODE – 4	SPARE
4	YAW DAMPER ENGAGED #2	DFGC #1 ACTIVE	DFGC #1 ACTIVE
3	APPROACH STATUS – 1	DFGC #2 ACTIVE	DFGC #2 ACTIVE
2	APPROACH STATUS – 2	ILS STATUS – 1	PA STATUS – 1
1 (LSB)	APPROACH STATUS – 3	ILS STATUS – 2	PA STATUS – 2

	WARNING DISCRETES ENGINE		WARNING DISCRETES		CONVERSION WARNING
BIT	TYPE	SIGNAL	TYPE	SIGNAL	OUT OF LIMIT PARAMETER
12 (MSB)	LATCH SE	MASTER WARNING	SHUNT	LOW OIL PRESSURE #1	LH/RH ELEVATOR
11	SHUNT	WINDSHEAR WARNING	SHUNT	LOW OIL PRESSURE #2	LH/RH AILERON
10	SHUNT	FADEC #1 OFF	SHUNT	LOW OIL PRESSURE #3	TE FLAP
9	SHUNT	FADEC #2 OFF	SHUNT	LOW OIL PRESSURE #4	AIRBRAKE
8	SHUNT	FADEC #3 OFF	SERIES	PYLON OVERHEAT #1	LH/RH ROLL SPOILER
7	SHUNT	FADEC #4 OFF	SERIES	PYLON OVERHEAT #2	PITCH TRIM
6	SHUNT	FADEC #1 FAULT	SERIES	PYLON OVERHEAT #3	RUDDER
5	SHUNT	FADEC #2 FAULT	SERIES	PYLON OVERHEAT #4	LONGIT ACC'N
4	SHUNT	FADEC #3 FAULT	SERIES	ENGINE FIRE #1	LATERAL ACC'N
3	SHUNT	FADEC #4 FAULT	SERIES	ENGINE FIRE #2	NORMAL ACC'N
2	SERIES	DFGC #1 MASTER	SERIES	ENGINE FIRE #3	BRAKES LH
1 (LSB)	SERIES	DFGC #2 MASTER	SERIES	ENGINE FIRE #4	BRAKES RH

	SUPERFRAME 1	SUPERFRAME 2	ILS 1 & 2 FREQUENCY
FRAME	PARAMETER	PARAMETER	PARAMETER
0	SELECTED MACH	SELECTED VERT SPEED	ILS #1 FREQUENCY
1	SELECTED ALTITUDE	SELECTED SPEED	ILS #2 FREQUENCY
2	SELECTED HEADING	SELECTED COURSE	ILS #1 FREQUENCY
3	CALIBRATION WORD	DAY/MONTH	ILS #2 FREQUENCY
4	SELECTED MACH	SELECTED VERT SPEED	ILS #1 FREQUENCY
5	SELECTED ALTITUDE	SELECTED SPEED	ILS #2 FREQUENCY
6	SELECTED HEADING	SELECTED COURSE	ILS #1 FREQUENCY
7	CALIBRATION WORD	CONVERSION WARNING	ILS #2 FREQUENCY

Parameter: Pressure Altitude (Fine)

Table 5 Source Definition

Signal Source/Type	Code Representation	Bits (Bit 0 = LSB)	Min Update Rate (times/sec)	SDI	
				10	9
A.D.C. 1 ARINC 429 DATABUS LABEL 203	BNR	28 to 11	62.5 ms (16/sec)	0	1
Resolution/LSB Value	Range		Accuracy		
1 ft	Operating - -1,000 to +50,000 ft Output - -2,000 to +50,000 ft		Defined in Ops Manual		

Table 6 Recording Definition

FDR Word No(s)	Superframe No.	Bits (Bits 1=LSB)	Sampling INT (Sec)
Octal: 071	N/A	12 to 2 (Bit 1 – Validity)	1
Decimal: 58 SF 1			
Resolution/LSB Value	Range	Conversion Accuracy	Overall RSS Accuracy
2 ft	-1,024 to 64,512 ft	-	Defined in Ops Manual

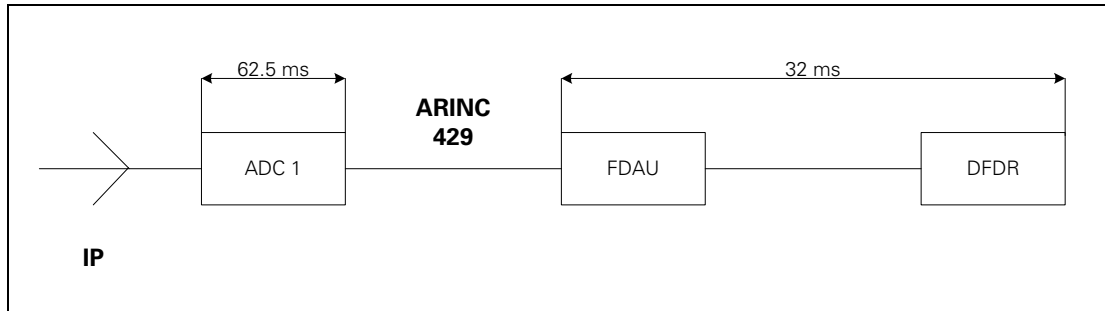

Figure 1 Transport Delay(s)

Algorithm

Defined in Ops Manual

Sign Convention Sign Bit 29 - 0 - Positive
(Digital Source) - 1 - Negative

Parameter: Pressure Altitude (Coarse)

Table 7 Source Definition

Signal Source/Type	Code Representation	Bits (Bit 0 = LSB)	Min Update Rate (times/sec)	SDI	
				10	9
A.D.C. 1 ARINC 429 DATABUS LABEL 203	BNR	28 to 11	62.5 ms (16/sec)	0	1
Resolution/LSB Value	Range		Accuracy		
1 ft	Operating - -1,000 to +50,000 ft Output - -2,000 to +50,000 ft		Defined in Ops Manual		

Table 8 Recording Definition

FDR Word No(s)	Superframe No.	Bits (Bits 1=LSB)	Sampling INT (Sec)
Octal: 022	N/A	12 to 8	4
Decimal: 19 SF 1			
Resolution/LSB Value	Range	Conversion Accuracy	Overall RSS Accuracy
2,048 ft	-1,024 to 64,512 ft	-	Defined in Ops Manual

Parameter: Computed Airspeed

Table 9 Source Definition

Signal Source/Type	Code Representation	Bits (Bit 0 = LSB)	Min Update Rate (times/sec)	SDI	
				10	9
A.D.C. 1 ARINC 429 DATABUS LABEL 206	BNR	28 to 15	62.5 ms (16/sec)	0	1
Resolution/LSB Value	Range		Accuracy		
0.0625 kt	Operating - 30 to 450 kt Output - 0.0 to 500 kt		60kt - +/- 4 kt 100kt - +/- 2 kt 200kt - +/- 1 kt 450kt - +/- 1 kt		

Table 10 Recording Definition

FDR Word No(s)	Superframe No.	Bits (Bits 1=LSB)	Sampling INT (Sec)
Octal: 011	N/A	12 to 2 (Bit 1 - Validity)	1
Decimal: 10 SF 1			
Resolution/LSB Value	Range	Conversion Accuracy	Overall RSS Accuracy
0.5 kt	0 to 1,024 kt	-	± 7% @ 60 kt ± 2% @ 100 kt ± 0.5% @ 200 kt ± 0.2% @ 450 kt

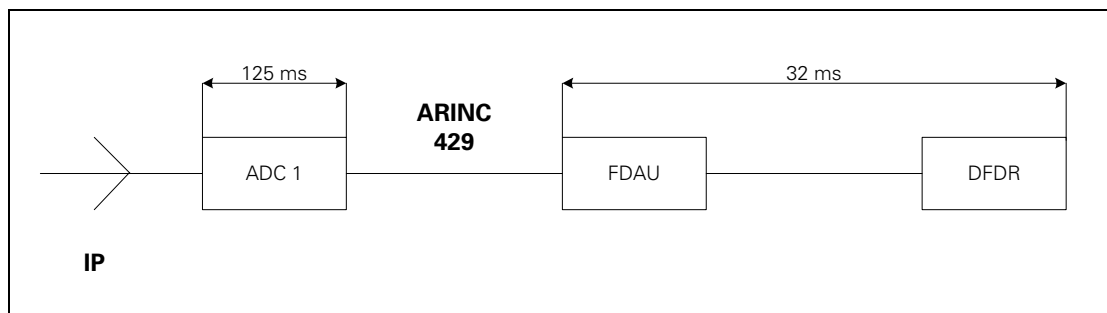

Figure 3 Transport Delay(s)

Algorithm

FDR Range 0 to 2,048 digital counts where:

Airspeed (kt) = 0.5 x (FDR digital count [11 BIT Res])

e.g. 30 = 15 kt; 450 = 225 kt



Sign Convention
(Digital Source)

Sign Bit 29 - 0 - Positive
- 1 - Negative

Parameter: Magnetic Heading

Table 11 Source Definition

Signal Source/Type	Code Representation	Bits (Bit 0 = LSB)	Min Update Rate (times/sec)	SDI	
				10	9
I.R.U. 1 ARINC 429 DATABUS LABEL 320	BNR	28 to 13	400 ms 2.5/sec	0	1
Resolution/LSB Value	Range		Accuracy		
0.0055°	± 180°		AT +/- 50° Lat - 2° 50 to 79° N Lat - 3° 50 to 60° S Lat - 3° Above 79° N Lat - 8°		

Table 12 Recording Definition

FDR Word No(s)	Superframe No.	Bits (Bits 1=LSB)	Sampling INT (Sec)
Octal: 010	N/A	12 to 2 (Bit 1 - Validity)	1
Decimal: 9 SF 1			
Resolution/LSB Value	Range	Conversion Accuracy	Overall RSS Accuracy
0.18°	0° to 360° (± 180°)	-	As Above

Table 14 Recording Definition

FDR Word No(s)	Superframe No.	Bits (Bits 1=LSB)	Sampling INT (Sec)
Octal: 003	N/A	12 to 1	0.125
Decimal: 4 SF 1			
Resolution/LSB Value	Range	Conversion Accuracy	Overall RSS Accuracy
0.00229g	-3.375g to +6.0g	±0.25%	±0.79%

Transport Delay(s)

FDAU/DFDR Conversion Delay Only = 32ms

Algorithm

FDR range 0 to 4,096 digital counts where:

$$\text{Acceleration (g)} = (2.289 \times 10^{-3} \times (\text{FDR Digital count (12Bit)})) - 3.375$$

Scale	Range	Output
Up	+6g	5000mV
Down	-3g	200mV

Sign Convention

(Digital Source) N/A

INTENTIONALLY LEFT BLANK

Appendix C Guidance on FDR Validation

Where an operator undertakes to carry out validation of their own FDR readouts this will be detailed in the company CAME. This validation will be undertaken by competent staff and will be documented.

A procedure should be established, acceptable to the CAA, which enables the operator to demonstrate that a timely validation has been carried out, which should highlight any deficiencies and the associated remedial actions. The procedure should also detail how system performance is assessed, and how that performance is included as part of the ongoing reliability system for each aircraft type.

The operator may sub-contract this task to an unapproved organisation and detail this in the CAME. However, this task will still form part of the operator's EASA Part M Sub-part G approval.

The Civil Aviation Authority recognises that in certain cases an aircraft operator may lack sufficient resources to undertake FDR readout validation. In these cases the validation, as detailed in the subject procedure, may be contracted to a third party by the operator. In these circumstances the operator will need to provide evidence of the following:

- The EASA Part 145 organisation has the validation of FDR readouts in their approved procedures.
- The EASA Part 145 FDR Readout Facility report should include an assessment in accordance with these procedures.

A copy of the test report and converted data from the representative flight should be provided to the operator together with an EASA Form 1, as detailed in Chapter 9, where deemed to be appropriate.

NOTE: The level of information provided will be dependent on the level of flight/aircraft information originally supplied.

In conclusion, there are three possible ways to comply with this requirement:

- 1 FDR readout and validation by the operator.
- 2 FDR readout and validation by an organisation under a sub-contract arrangement with the operator under the operator's Part M Sub-part G Approval.
- 3 FDR readout and validation by a suitably approved Part 145 organisation contracted by the operator.

INTENTIONALLY LEFT BLANK